

**INDUSTRIAL-BASED GSM WATER LEAKAGE DETECTION,  
MONITORING AND CONTROLLING SYSTEM: A CASE OF NORTH  
RIFT VALLEY WATER AGENCY IN KENYA**

**Dickson Tuwei Kipketer**

**A Project Report Submitted in Partial Fulfillment of the Requirements of the Award of  
the Degree of Master of Science in Embedded and Mobile Systems at the Nelson  
Mandela African Institution of Science and Technology**

**Arusha, Tanzania**

**June, 2024**

## ABSTRACT

The current system for detecting and monitoring water leaks in Kenyan industries is manual and costly. Despite emerging technological trends, many industries lack automated systems to detect, monitor, and control water leakage due to high maintenance and installation costs. This study aimed to develop an automatic, remote, real-time detection, monitoring, and control of water leaks in North Rift Valley Water Works Agency. The system is made up of two nodes, one at the source and another at the destination or tap. The two nodes are made up of an ESP32 Microcontroller, which is used to control all the connected components. The ESP32 Microcontroller was efficient due to its ability to provide WI-FI. Aside from the solenoid valve, which was used to turn the water flow on or off in the event of leaks, the system also includes the FY-201 water flow sensor, which was used to gauge the amount of water flowing through the pipe. Water leakage is detected when the water passing through the two sensors differs slightly, indicating that a water leakage has just occurred. Thing Board, an IoT-based platform used to monitor and visualize data from various connected devices, was used for real-time monitoring, visualization, and control. The system administrator could log into and manage the system by remotely turning the water leaks on and off from their phone. The database used was MySQL DB, and a system was created using C programming language, the Arduino Integrated Development Environment, HTML, and Cascading Style Sheet (CSS). The developed system was tested with different water service providers, including Eldoret Water and Sanitation Company, and the results show that the system responds positively to water leakage parameters. The developed system could monitor water leakages in real-time with the two nodes interacting by sharing information via the server and communicating via WI-FI enabled by the ESP 32 Microcontroller. With new technological trends, such as the Internet of Things, these microcontrollers will facilitate faster adoption in industrial projects. The benefits include that a system administrator can control the system remotely without physically switching the solenoid valve on or off. It is also lower in cost compared to other tariffs. The system can be installed in hazardous areas, such as valleys and mountains, making it attractive. Future research suggests more investigation into identifying leaks at particular points along water pipes by integrating with the Global Positioning System (GPS) to determine their precise location.

## DECLARATION

I, Dickson Tuwei Kipketer, declare to the Senate of the Nelson Mandela African Institution of Science and Technology that this project report is my original work and that it has neither been submitted nor concurrently submitted for a degree award in any other institution.

Dickson Tuwei Kipketer

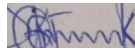

12-06-2024

---

**Name of Candidate**

**Signature**

**Date**

The above declaration is confirmed by:

Dr. Neema Mduma



12-06-2024

---

**Name of Supervisor 1**

**Signature**

**Date**

Dr. John Tarus



12-06-2024

---

**Name of Supervisor 2**

**Signature**

**Date**

## **COPYRIGHT**

This project report is copyright material protected under the Berne Convention, the Copyright Act of 1999, and other international and national enactments on behalf of intellectual property. Accordingly, it must not be produced by any means, in whole or in part, except for short extracts in fair dealing, for private researcher study, critical scholarly review, or discourse with an acknowledgement, without the written permission of the office of Deputy Vice-Chancellor for Academic, Research, and Innovation on behalf of the author and the Nelson Mandela African Institution of Science and Technology.

## CERTIFICATION

The undersigned certify that they have read and, with this recommendation for acceptance by the Nelson Mandela African Institution of Science and Technology, a project report titled *“Industrial GSM Based Water Leakage Detection, Monitoring and Controlling System: A Case of North Rift Valley Water Agency in Kenya”* in partial fulfilment of the requirements for the degree of Master of Science in Embedded and Mobile Systems of the Nelson Mandela African Institution of Science and Technology.

Dr. Neema Mduma		12-06-2024
<b>Name of Supervisor 1</b>	<b>Signature</b>	<b>Date</b>

Dr. John Tarus		12-06-2024
<b>Name of Supervisor 2</b>	<b>Signature</b>	<b>Date</b>

## **ACKNOWLEDGMENTS**

I am expressing my gratitude to the Almighty God for the life, power, and might he give me throughout the project.

I want to thank my Nelson Mandela African Institution of Science and Technology supervisors for their guidance. The Nelson Mandela African Institution of Science and Technology (NM-AIST) for providing me with a facility and a welcoming environment that helped me finish my project. The Center of Excellence for East Africa (CENIT@EA) and DAAD GIZ's scholarship program for funding the project.

I want to thank my academic supervisors, Dr. Neema Mduma and Dr. John Tarus, for their guidance throughout the research period and my industrial supervisor, Mr. Abharam Birgen of the North Rift Valley Water Works Development Agency, for his assistance during my internship.

I will also not forget my mentor, Dr. Rev. Daniel Lagat, who has mentored me since the beginning of my educational journey. Finally, I would like to officially dedicate this work to my lovely wife, Sheilah, for her moral support and, more importantly, encouragement throughout my studies.

## **DEDICATION**

I dedicate this work to my parents, friends, and entire family for their encouragement throughout my entire course of study and to my fellow students with whom I was enrolled in the program for their knowledge-sharing and exchange.

## TABLE OF CONTENTS

ABSTRACT.....	i
DECLARATION .....	ii
COPYRIGHT.....	iii
CERTIFICATION .....	iv
ACKNOWLEDGMENTS .....	v
DEDICATION.....	vi
LIST OF TABLES .....	x
LIST OF FIGURES .....	xi
LIST OF APPENDICES.....	xiii
LIST OF ABBREVIATIONS AND SYMBOLS .....	xiv
CHAPTER ONE.....	1
INTRODUCTION .....	1
1.1 Background of the Problem .....	1
1.2 Statement of the Problem.....	4
1.3 Rationale of the Study.....	5
1.4 Objectives of the Study.....	5
1.4.1 General Objective.....	5
1.4.2 Specific Objectives.....	5
1.5 Research Questions .....	5
1.6 Significance of the Study .....	5
1.7 Delineation of the Study .....	6
CHAPTER TWO .....	8
LITERATURE REVIEW .....	8
2.1 Related Works.....	8
2.2 Summary of Existing Systems .....	12

2.3	Theoretical Background of Study .....	13
2.4	Conceptual Framework .....	14
CHAPTER THREE .....		15
MATERIALS AND METHODS.....		15
3.1	Study Area .....	15
3.1.1	Sample Size and Sampling Technique .....	15
3.1.2	Data Collection Methods.....	15
3.1.3	Secondary Data .....	17
3.1.4	Data Analysis .....	17
3.1.5	Ethical Consideration .....	18
3.2	Materials .....	18
3.3	Software Requirements .....	23
3.3.1	Integrated Development Environment .....	24
3.4	System Development Approach .....	25
3.4.1	Advantages .....	25
3.4.2	Disadvantages.....	25
3.5	System Design .....	25
3.5.1	Conceptual Diagram.....	26
3.5.2	Context Diagram .....	27
3.5.3	Block /Architectural Diagram .....	28
3.5.4	Flowchart Diagram.....	29
3.5.5	Software and Hardware Tools Used.....	29
3.5.6	Things Board Architecture .....	32
3.5.7	Circuit Diagram.....	34
3.5.8	Benefits of the Developed System .....	35
3.6	System Testing and Validation .....	35
3.6.1	Unit Testing.....	35

3.6.2	Integration Testing .....	36
3.6.3	System Testing .....	36
3.7.4	User Acceptance Testing .....	36
3.7	Requirements for the Proposed Industrial GSM-Based Water Leakage Detection, Monitoring and Controlling System .....	37
3.7.1	Functional Requirements .....	37
3.7.2	Non-functional Requirements .....	37
CHAPTER FOUR.....		39
RESULTS AND DISCUSSION .....		39
4.1	Results.....	39
4.1.1	Gender Respondents During Questionnaire.....	39
4.1.2	Staff Response from the Company.....	39
4.1.3	Years of Experience in the Company.....	40
4.1.4	Proposed System from Correspondents .....	41
4.1.5	Web-based Application .....	42
4.1.6	The Working of the System .....	48
4.1.7	Communication Mechanism .....	49
4.1.8	System Implementation Overview .....	49
4.1.9	User Acceptance Testing.....	51
4.2	Discussion.....	52
CHAPTER FIVE .....		53
CONCLUSION AND RECOMMENDATIONS .....		53
5.1	Conclusion .....	53
5.2	Recommendations.....	54
REFERENCES .....		56
APPENDICES .....		58
RESEARCH OUTPUTS.....		73

## LIST OF TABLES

Table 1:	Summary of the existing systems .....	12
Table 2:	The ESP32 comparison with other Single-Board Computers (SBC's) .....	19
Table 3:	Specification of the gravity solenoid valve .....	23
Table 4:	Functional requirements .....	37
Table 5:	Non-functional requirements .....	38
Table 6:	Responses from Staff .....	40
Table 7:	User Authentication Unit Testing .....	44
Table 8:	User Acceptance Testing .....	52

## LIST OF FIGURES

Figure 1:	Forecast of water stress by 2040 .....	1
Figure 2:	Water Leakages .....	2
Figure 3:	Water scarcity in Africa .....	3
Figure 4:	Conceptual framework of developed system .....	14
Figure 5:	Outer layout of ESP32.....	20
Figure 6:	Inner layout of ESP32 .....	21
Figure 7:	The YF-201 water flow sensor .....	22
Figure 8:	Piezo buzzer .....	22
Figure 9:	Gravity solenoid valve .....	23
Figure 10:	Screenshot of the Arduino IDE .....	24
Figure 11:	Extreme programming development cycle.....	26
Figure 12:	Conceptual diagram.....	27
Figure 13:	Context diagram .....	27
Figure 14:	Block /Architectural Diagram .....	28
Figure 15:	Flow chart diagram.....	29
Figure 16:	The XAMPP Control Panel.....	30
Figure 17:	Proteaus diagram representation .....	30
Figure 18:	Things board architecture .....	32
Figure 19:	Circuit of power design .....	34
Figure 20:	The pinout layout of the internal section of the ESP32 microcontroller.....	34
Figure 21:	Gender response pie chart .....	39
Figure 22:	Respondents distribution by category .....	40
Figure 23:	Years of experiences .....	41
Figure 24:	Respondents on water leakages .....	41
Figure 25:	User-proposed system features.....	42

Figure 26: The login page of Things Board.....	43
Figure 27: Dashboard of Thing Board .....	44
Figure 28: Dashboard for controlling water Taps.....	45
Figure 29: Total flowrate and amount of water in both taps.....	45
Figure 30: Total amount of water in Source and Tap .....	46
Figure 31: Total flowrate of water in Source and Tap.....	46
Figure 32: Control Switches as Source and Tap.....	47
Figure 33: Source Node Subsystem.....	50
Figure 34: Destination/Tap Node Subsystem .....	50
Figure 35: Integration of source and destination subsystem.....	51

## LIST OF APPENDICES

Appendix 1: Questionnaire for System Validation.....	58
Appendix 2: Development of an Industrial GSM-Based Water Leakage Detection, Monitoring and Controlling System.....	59
Appendix 3: Interview Guide.....	63
Appendix 4: Internship Letter.....	64
Appendix 5: Arduino UNO Program Code for Real-Time Water Leakage Detection, Monitoring and Controlling System.....	65
Appendix 6: Poster Presentation.....	74

## LIST OF ABBREVIATIONS AND SYMBOLS

APA	American Psychological Association
API	Application Programming Interface
CMT	Corporate Management Team
CSS	Cascading Style Sheet
DC	Direct Current
ELDOWAS	Eldoret Water and Sanitation Company
ESP	ESPressif Module
GSM	Global System for Mobile Communication
HTML	Hypertext Markup Language
I2C	Inter-Integrated Circuit
ID	Identity Document
IDE	Integrated Development Environment
IEEE	Institute of Electrical and Electronic Engineer
LCD	Liquid Crystal Display
MQTT	Message Query Telemetry Transfer
MYSQL	My Structured Query Language
PC	Personal Computer
PHP	Hypertext Preprocessor
PLC	Programmable Logic Controller
PVC	Poly vinyl Chloride
REST	Representational State Transfer
RPC	Remote Procedural Call
SBC'S	Short Board Circuits
SPI	Serial Peripheral Interface
SQL	Structured Query Language

UART	Universal asynchronous Receiver-Transmitter
UNICEF	United Nations International Children's
US	United State
WIFI	Wireless Fidelity
WPA	Wi-Fi Protected Access
XP	Extreme Programming

# CHAPTER ONE

## INTRODUCTION

### 1.1 Background of the Problem

Water is one of the most vital elements on the planet and plays an important role in our daily activities. It is a critical resource of the earth and serves many functions for human life. Therefore, there is a need to develop measures and methods to ensure that this precious resource continues to sustain the human race's survival. Water stress in the world has been a pressing concern for many decades now. Figure 1 shows a projected water scarcity stress in the world by 2040.

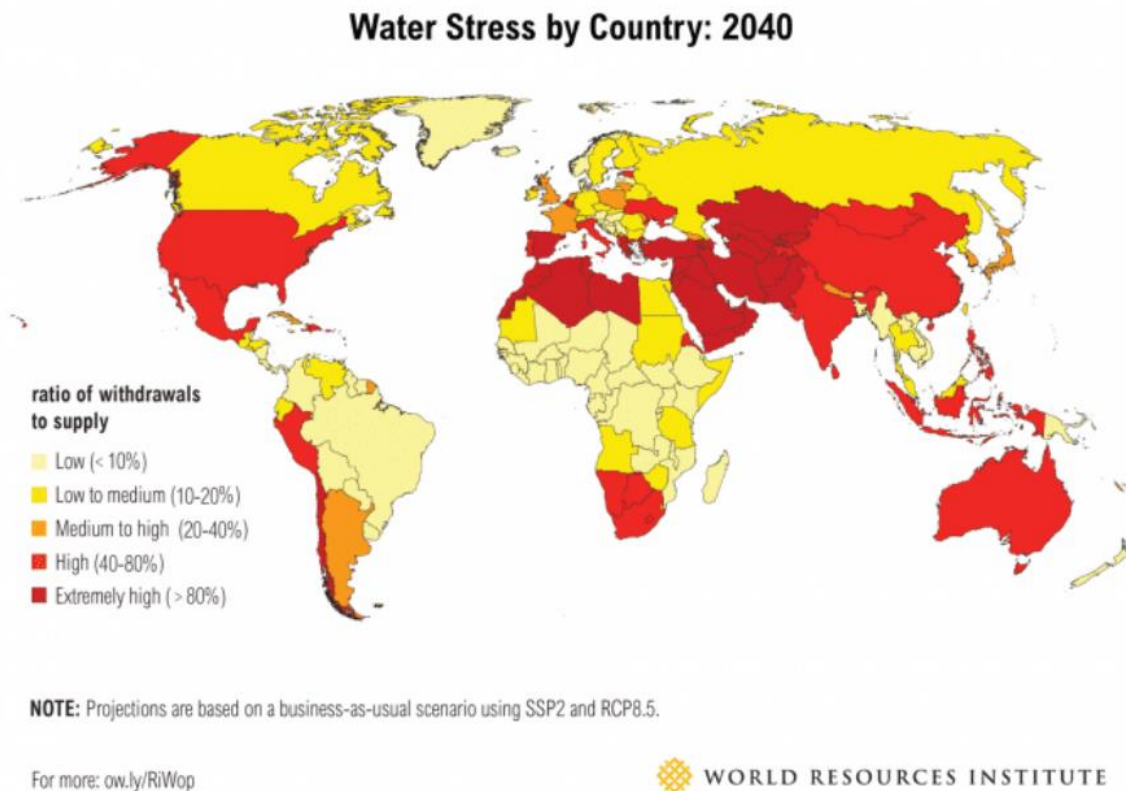

**Figure 1: Forecast of water stress by 2040**

The threat to water availability has been narrowed down to global population and global warming. The growth of the world population is happening at an alarming rate, making water resources increasingly scarce. It indicated that the global population is increasing alarmingly, which must be considered. This results in the depletion or scarcity of resources, one of which is water, which plays an important role in human life (United Nations *et al.*,2019). Global

warming and climate change are two key factors that have resulted in the water shortage. Global warming is one significant threat to the human race that has caused water depletion (Urama & Ozor, 2010).

The World Resources Institute projected that even developed regions like the southwestern US and China's Ningxia province could face an increase in water stress of 40% to 70 % and statistics by country are shown in Fig. 1 (Madlocks, 2015).

Another factor that threatens water sustainability is irresponsible water management. Collapsed and obsolete infrastructure and lack of proper mechanisms to manage scarce resources have resulted in the world's water shortage (Bhattacharjee, 2010). Figure 2 depicts how water is mismanaged in East Africa due to leaks caused by poor infrastructure. Poor infrastructure contributes significantly to water leakages because there are no proper mechanisms in place to manage water leakages in the face of water scarcity. Water leaks are the primary cause of water waste.



**Figure 2: Water Leakages**

This problem relates to human behaviorism, sometimes resulting in arsonry or buglery of water resources or equipment, turning water shortage into a catastrophe that could further lead to starvation and deaths. Figure 3 depicts some people in East Africa who are affected by water scarcity, and nearly two-thirds of the global population is affected by water scarcity for at least one month out of every 365 days (UNICEF, 2020).



**Figure 3: Water scarcity in Africa**

Several countries have responded to water crises in various ways. Asian countries, particularly the Gulf countries (Bahrain, Kuwait, Oman, Qatar, Saudi Arabia, and the United Arab Emirates), which are considered the most water-stressed countries globally, are trying to get their water through groundwater drilling, desalination of seawater, and wastewater treatment (Salem *et al.*, 2022). In Northern Africa, wind power pumps water from wells and rivers for domestic consumption and agriculture (Birhanu *et al.*, 2023). In Kenya, the water crisis is addressed by established agencies that aim to develop water infrastructure for its citizens. One of the agencies is the North Rift Valley Water Works Development Agency, one of the nine agencies in Kenya that serve four counties in conjunction with the Eldoret Water and Sanitation company limited to provide water to its residents in the area of jurisdiction.

The most formidable intervention in the current times is technology (Kram *et al.*, 2023). As an intervention to the water crisis, Yıldırım (2015) argues that technological research is necessary to solve the water shortage by using various devices to manage water. Unfortunately, there are various existing methods used to detect leakages that are still unable to provide the maximum mechanism to solve the water leakage problems because they are incapable of detecting leakage (Al-Qahtani *et al.*, 2020). Hence, there is a need to develop a system that can detect water leakages, especially in pipeline systems, despite the complexity of water distribution networks, which is the underlying research problem in this project.

An assessment of all features of currently existing systems reveals a need to develop a system that can detect, monitor and control water leakages. The proposed system consists of

technologies that use the Internet of Things, designed to control water leakages. This study investigated a solution to develop a system capable of detecting, monitoring, and controlling water leaks.

## **1.2 Statement of the Problem**

The main problem Eldoret Water and Sanitation Company (ELDOWAS) faces is the lack of an automated and affordable system that detects, monitors, and controls the water leakages from the source to the consumers. The company has a system in place that can supply water to consumers, but the company is unable to detect water leakages automatically in real-time. As a result, the company loses a lot of revenue collection due to water leakage. This is shown by the evidence in the record of the company the amount of water supplied per day is a hundred thousand litres due to water leakages around ten thousand litres is lost in the supply line which indicated that just eighty thousand liters of water reached the distribution tank from the treatment area and subsequent breakages of water pipes as a result of delayed repairs. Sometimes, the failure to detect leakages also leads to theft or damage of pipes due to a lack of mechanisms to detect fault. This also leads to other social problems, such as the impossible distribution of equal water to consumers. The company receives a lot of complaints due to the fact that water is not reaching some clients.

In ELDOWAS, water is supplied to consumers daily, except during maintenance, when the water is cut off. The problem of water leakages has risen because the company does not have an automatic system to detect, monitor, and control water leakage despite having a system that can track water payments. They still lack a system to detect water leakage, a major water supply issue. The existing system allows the user to pay for water using the M-Pesa Pay-Bill, provided by the service provider for the number of liters used per month.

Among the problems that consumers face is a cut-off and infrequent water supply, and the service provider will incur the cost of maintenance, treatment, and water supply.

According to the information from the water service provider, there is a lot of disparity between the projected revenue to be collected at the end of the month and the actual revenue collection. The company's projected monthly revenue was fifteen million Kenya shillings. Still, it collected a revenue of thirteen million shillings, indicating that two million was lost due to water leakages. This implies that it is necessary to develop a system capable of detecting, monitoring, and controlling water leaks to prevent revenue loss from water leakages.

### **1.3 Rationale of the Study**

The motivation for this study is the increase in water demand due to urbanization and the growth of diverse uses such as agriculture, industry, housing, and hospitals. Moreover, humanity is rapidly anticipating adapting and introducing new technologies to improve the quality of life and consumption patterns. As a result, it is important to respond to the pressing need to integrate ICT technologies into water-efficient activities as much as possible.

### **1.4 Objectives of the Study**

#### **1.4.1 General Objective**

To develop an industrial-based GSM water leakage detection, monitoring, and control system.

#### **1.4.2 Specific Objectives**

The study aimed to achieve the following specific objectives:

- (i) To gather requirements for an industrial-based GSM water leakage system.
- (ii) To develop an industrial-based GSM water leakage system.
- (iii) To validate the developed industrial-based GSM water leakage system.

### **1.5 Research Questions**

The study intended to answer the following questions:

- (i) What are the requirements for an industrial-based GSM water leakage system?
- (ii) How can the industrial-based GSM water leakage system be developed?
- (iii) Will the developed industrial-based GSM water leakage system meet the user's requirements?

### **1.6 Significance of the Study**

Water leakages have long been a problem for industries and businesses that provide water services (Bhagat *et al.*, 2019). Given that one of the most crucial aspects is revenue collection that led to the growth of a water service provider and that the company has invested a significant

amount of money in constructing and developing water infrastructure, the return on investment is still low in comparison to the investment, and this calls for immediate intervention by various stakeholders and researchers to address the issue of water leakages.

One of the major stakeholders in this study was engineers, who were part and parcel of the research on the problem. All the engineers and technicians agreed together in one voice, admitting that there was a water leakage problem in their company, and they expected that the proposed system would be able to solve the problem of water leakages. This follows the recommendation of a proposed system that will automatically detect and control water leakages.

According to previous research, the problem of water leaks has not been fully resolved. Various technologies have been developed to address and solve the problem of water leakages, such as implementing various systems ranging from water leak detection and control. However, the existing approaches have not been fully efficient and effective because they only send SMS notifications to the authorities. Based on the various published papers, the water leakage gap remains an unresolved research problem.

This brings to light the significance of this project in providing a solution for reducing water leakages. The focus of this project is to ensure that the water service provider makes the most profit from the water supplies because the proposed system will detect, monitor, and control water leakages. The project's sole purpose is to ensure service providers maximize revenue by reducing non-revenue collection caused by water leakages. Think Board, an IoT-based platform that the company can use to monitor water leakages and data visualization from the source to the end point in the pipeline, is one of the common technologies that facilitated efficiency and effectiveness in the proposed system.

## **1.7 Delineation of the Study**

The project's scope is limited to the service provider, and the majority of the research was conducted within the company because the developed system was used exclusively by the company. Given that the study was conducted within the company, this also applies to the research strategy, which includes interviewing respondents, particularly civil engineers, because these were the people most familiar with the water leaks.

Because this study was limited to the number of people interviewed, the aspect of the clients who were the company's customers was not given as much attention. However, some were interviewed to gather their thoughts on water leaks. The study was narrowed down to the company because the staff had the necessary skills, experience, and understanding of technical terms for the system's development and implementation.

## CHAPTER TWO

### LITERATURE REVIEW

#### 2.1 Related Works

Water leaks have been the subject of numerous research studies. For instance, Palpandian *et al.* (2021) developed a water pipeline leakage detection and control management system based on the Think Speak cloud platform. Their research allowed users to access uniform data by registering on their internet services and declaring their login credentials, mainly passwords and consumer IDs. The parameters were displayed to minimize water waste in the long term, and the system was able to manage the apartment where it was built. However, the leakage, which is the parameter, was used to detect such as the water flow. Depending on the various measured data, the sensor used could examine in real time. In their system, the specific person receives a message alerting the user to prevent water leakage when the water reaches a certain threshold limit.

A similar study was also conducted to develop a flow liquid meter sensor for water pipeline monitoring and leak detection (Rahmat *et al.*,2017). Their system's objective was to increase system performance in terms of tracking and finding water leaks in underground pipes. The system's performance was tested using a 5-meter length of PVC pipe. Where the normal flow of water in the pipe and the sensor are configured so that each hole remains closed, the Arduino detects the presence of leaks every time the hole opens. During the stage where the system's performance was tested, the graph changed automatically every two seconds during the water monitoring flow rate. One of the limitations of this proposed system is that the system performance test, detecting location, was done ten times in each variation in the water flow rate, resulting in wasted time.

Moreover, Sithole *et al.* (2016) developed a smart water leakage detection and monitoring device. The study covered the monitoring and detection of water leaks. The device contains a flow water sensor used to calculate the amount of water consumed, and the system displays the water flow rate. It indicates a variable small device used to detect spillage in the customers' homes and display the current household water consumption in real-time. All system information is transmitted to the website via GSM. One advantage of this research is that the system was designed to be efficient and precise to reduce commercial losses. It was efficient because it could send data from the node to the website.

Similarly, Lakshmi and Gomathi (2015) studied improving the wireless sensor network's ability to detect and monitor leaks in underground water pipelines. Their study aimed to monitor water spillage by observing, discovering, and distinguishing spills using a remote wireless sensor. The upgraded remote sensor framework aims to locate underground water spillage and individual water pipes monitored by the PC. Wireless sensor network: An interconnected network of sensor nodes communicating wirelessly to collect data about their surroundings. It comprises low-power and distributed nodes (Sohraby *et al.*, 2007).

The remote wireless sensors collect all of the information and send it to the central node, which then channels it to the PC to analyze and identify the correct spillage position. On printed circuit boards, wireless sensors were arranged, and a PC displays data from various remote sensor types, including weight and sound. The responsible authority was the one to go and fix the spillage once the break had been identified. The benefit of this research is that it aimed to use wireless sensor node technology to collect various parameters and monitor them on a PC. One overlooked limitation is the security aspect, which could be tampered with or hacked into the sensor nodes to obtain data.

Jayapal (2022) conducted research based on water leakage management. The study used digital twin technology to manage water leakage. Various sensors were placed near the input source, where network signal strength was reliable. Over 60-70 sensors were installed in various locations, and those sensors were linked with ESP8266 to collect all data and store it in a database. The sensors were intended to gauge the water flow rate through the pipe at various points and send the data to the firebase, where the digital twin would oversee and manage the data before sending it to the 3D Maya software, which was used to analyze the data. If a leak is detected, the system will send an email informing the user of the appropriate action. One of the limitations of this study is the use of many sensors in various locations, which increases the cost.

Furthermore, Zhang *et al.* (2020) researched the localization and detection of water leaks. The research was based on water leaks, and various environmental parameters were collected to determine the strength of the signal used to locate the water leaks in the pipeline: Flowmeter, pressure gauge and vibration sensor. Their proposed system continuously collects signals to identify and notify users of water leaks. The GCC-PHAT algorithm, which adjusts the pertinent parameters by examining the vibration sensor data and subsequently calculating the leakage point, was used to determine where the leakage occurred. The acquired signal is connected to

the PLC via an RS 485 communication line, and data is transmitted to the PC via a network. The positioning error is less than one meter. The data acquisition, preliminary pipeline leakage assessment, and vibration signal processing were the main responsibilities of the PLC module. The PLC uses the MODBUS-RTU protocol to collect real-time data from six on-site instruments and send it to the PC. The system uses the GCC-PHAT algorithm to process the data, and the PC saves the data to a SQL database so that computers can respond in kind. Customers can access specific website data once all data has been analyzed and judged. The algorithm is crucial to the study because it helps with noise suppression, related signal highlighting, and power signal weighting. According to the GCC-PHAT function's precision, the higher the value, the more accurately the sound source signal will be picked up. The limitation of their study is that the algorithm sometimes does not give an accurate value because the output depends on the parameters collected.

Another related research conducted by John and Nivash (2016) is based on the development of monitoring and controlling water leakages using robotic arms. The proposed system consisted of an ATMEGA 328P microcontroller, a humidity sensor, a solenoid valve, and a Zigbee module installed in a water tank. The buzzer ring performed the humidity sensor, which accomplished leak detection and user notification as the information was shown on the LCD module. A solenoid was used to open and allow water to flow. The Zigbee module was built into the robotic module. When the robotic arm receives a signal, it will proceed to the tank and seal the leak. The system was divided into two sections, transmitter and receiver, with power connected to the microcontroller. The robotic arm opens and closes the leakages, and the motor driver controls and interfaces a DC motor with a microcontroller. The robotic occasionally receives signals that are too weak to move the arm to the tank and stop the leak, which is one limitation of the proposed system.

Hattaraki and Yaragal (2021) also studied water leakage and theft detection using IoT. The study aimed to enhance water management. They achieved the study by designing the proposed system, including the various sensors and NODEMCU used as the microcontroller that connected all the devices. Their system consists of two flow sensors, inflow and outflow sensors, that measure the water flow rate and a solenoid valve that regulates the valve's opening and closing. Their proposed system also contains an application to monitor real-time water leakages.

Their system determines the occurrence of water leakage by setting a threshold value, in this case, the threshold value of 2-3 litres. The findings of their study were that it was able to detect water leakage, and the application was automatically alerted when water leakages in the pipe occurred. One of the limitations of their research is that it did not cover the water distribution networks, which allow water to branch into different branching points.

In addition, Thilagaraj *et al.* (2020) conducted a similar study to create an IoT-based system for detecting and managing water leaks. The developed system was made of water quality, leak detection and level monitoring tubes. The system comprises an ultrasound sensor that measures the water tank level by emitting small, high-frequency sound pulses. The flow sensor to detect leakage in a pipe was used for flow measurements. The data collected by the flow sensor is sent to the cloud for storage, and the cloud services allow the email to be sent to the client's home. This system consists of the gateway, which is the main purpose of data logging and transfer. The findings of the proposed system were that it was able to develop an intelligent water leak detection and control system that could detect leaks and monitor the level of water by using the wireless network.

## 2.2 Summary of Existing Systems

**Table 1: Summary of the existing systems**

<b>Reference</b>	<b>Problem Addressed</b>	<b>Proposed Solution</b>	<b>Limitations of the study</b>
Rahmat <i>et al.</i> (2017)	The objective was to increase system performance by tracking and finding water leaks in underground pipes.	Develop a water pipeline monitoring and leak detection system using a flow liquid meter sensor.	The system performance test for detecting location was repeated ten times for each variation in the water flow rate, resulting in time waste.
Sithole <i>et al.</i> (2016)	It aims to detect spillage in the customer's household and display current household water consumption in real time.	Develop a smart water leakage detection and monitoring device.	The system was expensive because it required monthly subscriptions for customers to receive SMS notifications.
JayaLakshmi and Gomathi (2015)	The study's goal was to monitor water spillage by observing, discovering, and distinguishing spills with the help of a remote wireless sensor.	Develop an improved wireless sensor network for monitoring and detecting leaks in underground water pipelines.	Data from the various wireless sensor nodes could pose a threat to hackers and compromise the system's security.
Zhang <i>et al.</i> (2020)	Water leak research in which environmental parameters were collected to determine the strength of the signal to be used in locating water leaks in the pipeline.	Develop water leakage detection based on localization	An algorithm does not always provide an accurate value because the value output depends on the parameters collected.

### 2.3 Theoretical Background of Study

The studies and theories produced by the early research on the internet of things serve as the basis for this study. This research aims to understand better how the internet of things can be used to increase the efficient use of water in major water service providers. The study is based on two theories created to address the internet of things as a new trend in technology. These theories include the Semantic Theory of the Internet of Things and the Internet of Things Interface Theory.

These two theories led to the creation of this study, which addresses various applications of the internet of things based on various aspects of the problem statement. To establish the main goal of this study, the first was based on an analysis of the theory of semantic by Lanotte and Merro (2020), which states that the Internet of things (IT) paradigm, smart devices equipped with embedded technology. In other words, IoT is a new technology that is viewed as the collection of various entities of interconnected devices that aggregated together to exchange data, and this study is based on the theory to apply this technology to the field of water where the IoT will be used in water leakage detection and monitoring.

The interface theory of the internet of things, developed by Lohstroh *et al.* (2019), is the second theory. Two researchers in this work used interface automata to develop an interface theory for a component architecture for an Internet of Things application. They looked at an architecture for the Internet of Things applications and claimed it is based on so-called accessors, which offer devices and services an actor-oriented proxy. The actor and accessor respond to input stimuli according to the actor's models, and the accessor then provides an output that can cause reactions in additional accessors or actors. They also look at how time-sensitive IoT applications are made possible by the accessors and actors being time-stamped events. The IoT architectural application generally consists of sensors, actuators, and control units that collaborate to transmit data; this study demonstrates how important IoT applications are.

Further research starts based on the two theories, the semantic theory and the interface theory, which address the presence of the Internet of Things. Based on prior or, more accurately, current related efforts on the Internet of Things, particularly its use in detecting, monitoring, and controlling water leaks.

According to a literature analysis of earlier studies, the usage of the internet of things has not yet been fully realized, notably in the detection and monitoring of water leaks. Previous studies

explored using the Internet of Things to detect water leaks using various methods and technology, including web-based applications, robotic valve-control arms, and various sensors. Although they were able to manage the detection of water leaks to some extent, they encountered some limitations, including the inaccuracy of the sensor and the fact that their system did not automatically detect water leaks.

This study focused on and addressed the problem of automatic detection of water leakage and real-time monitoring of water leakage using the Internet of Things platform, or Thing speak, which was able to visualize the real-time data and allow the admin to remotely control the valve to prevent the loss of water due to the water leakages.

## 2.4 Conceptual Framework

Figure 4 shows the conceptual framework of the developed system of water leakage detection, monitoring, and control.

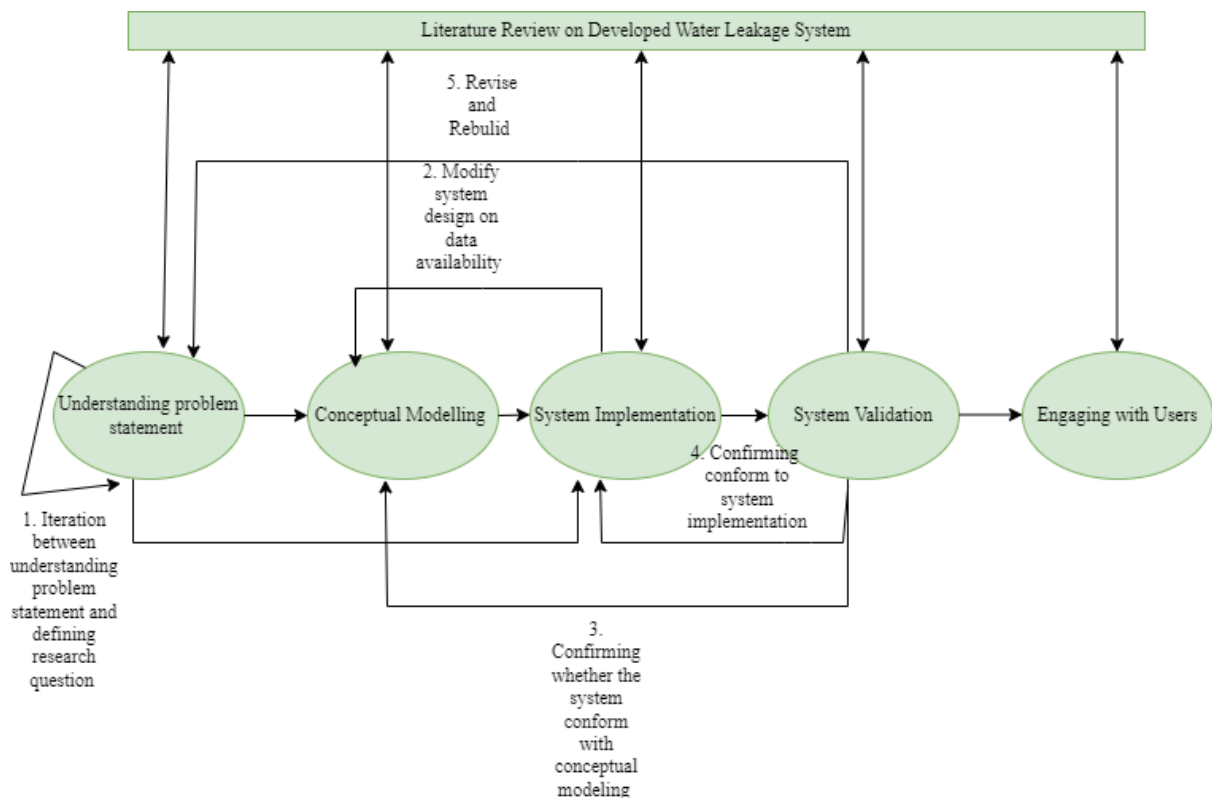

**Figure 4: Conceptual framework of developed system**

## **CHAPTER THREE**

### **MATERIALS AND METHODS**

#### **3.1 Study Area**

Eldoret Water and Sanitation company limited (ELDOWAS), one of the water service providers under the North Rift Valley Water Works Development Agency, was the area of the research. The ELDOWAS organization is divided into four departments, the first is the technical department, which is in charge of developing water sources, distributing water, and treating it. The commercial one is in charge of revenue collection and billing. The role of the finance department is financial management, whereas the administration department deals with employees and plans the company's operations. A Corporate Management Team (CMT) includes the managing director, the head of financial services, the head of technical services, and the head of commercial services.

The company is in charge of providing water to the residents of Eldoret and its environs. This company was chosen for the study because it is the main water supplier to its people and has been affected by the water leakage problem. As a result, this was useful in providing information and aiding in the system's design, development, and validation.

##### **3.1.1 Sample Size and Sampling Technique**

The study used non-probability sampling techniques to identify the sample size. Fifteen was the sample size used during data collection, with 10 Engineers and 5 Technicians participating in the survey. The non-probability sampling method was used, especially purpose sampling, based on the researchers' subjective judgment.

##### **3.1.2 Data Collection Methods**

This study's data came from two different sources. One of the sources is primary, which was critical in carrying out this study. The primary data helped get the requirements for an industrial-based GSM water leakage system, which is this project's first objective. The secondary data helped clarify how industrial-based GSM water leakage system worked in similar studies and projects, and it is important to answer the three research questions. The main component of the research was the primary data collected from the Eldoret water and sanitation company's staff. The primary data was collected from the staff's real environment,

and this data has not been published. This information was gathered through an interview and questionnaire the company's engineer administered.

The primary data was obtained from the engineers and technicians of ELDOWAS. The data collection methods were as follows: interviews shown in Appendix 3, questionnaires, focus group discussions, observation, and face-to-face conversation. The discussion method was used to collect information from the engineers by analyzing the existing problem, assessing the system, and determining the system's strengths and weaknesses. During the system assessment, it was analyzed to determine the system strength level, followed by estimating various functionalities. System parameters were considered, such as the security and dependability of the existing system and the system to be developed.

The focus group represents the small number of participants in the discussion. Ten civil engineers participated in a focus group discussion during the data collection period. These were the people who had the same experience in terms of water leakage knowledge and the same skills, as well as professionals who were civil engineers. These were the people who took part in the focus group. Focus groups were used in this case because of the following benefits.

Because the information was obtained directly from the source, gathering information on water leaks took less time. Due to the focus group participants' familiarity with the issue of water leaks, additional information was collected, allowing for the rapid collection of a large amount of data. Additionally, this method offers insight into how information relevant to the entire data collection process was gathered from civil engineers.

Engineers were interviewed as part of the data collection process to get their views and opinions on the existing system and whether it was serving their needs or if they preferred a better system that could serve their daily operation's needs. According to the interview, 12 Engineers and Technicians were interviewed. Furthermore, the company system was observed to see how the existing system functions in functionality and usability. This was followed by identifying the gaps in the current system and recording their thoughts on the proposed system.

Additionally, questionnaires were used to gather information on their opinions of the current system, gauge their level of satisfaction and the difficulties they encountered, and offer suggestions and improvements that needed to be added to the proposed system. According to the data collected from the 20 respondents who were administered the questionnaire, only 15

people responded to the questionnaires, with the civil engineers being the most numerous among those who provided feedback, constituting the majority of the company's personnel.

### **3.1.3 Secondary Data**

Secondary data was obtained through document review from various sources, including books, journals, articles, conference papers, and internet searches, to supplement the relevant information. After the secondary data collection, it was analyzed to determine what problem the researchers were attempting to address and solve, as well as how the recommendations highlighted would be used to close the existing gap.

### **3.1.4 Data Analysis**

The system requirements arose from data collection from users, which were the Eldoret Water and Sanitation Company staff. An online survey was conducted in which the Google form was administered and sent to the respondents to respond to the questionnaire; each time a respondent submitted a response, the Google form was examined, as shown in Appendix 2. Google Forms is an online platform used to analyze data, capture individual responses, and provide an overall summary of all the questions that respondents responded to and their answers. This was a more efficient way of analyzing the data, namely, the gender distribution of the respondents. According to Fig. 2, most of those who responded to the survey were men, 69.2% and female gender 30.8%.

Additionally, an interview guide was created for use during the interview. It included questions related to the current system and water leakage in general. The interview responses were analyzed so that the number of respondents was categorized based on gender, role, number of respondents, and percentage. These were all incorporated into the table for easy analysis using the graph that gives accurate information about the data, as shown in Table 6.

Focus groups, on the other hand, the data gathered and analyzed show the number of respondents who took part in the focus groups, the number of respondents involved, and their proposal on the developed system. Their data were incorporated into the graph, giving various percentages on their proposal for the developed system. In contrast, the related works document review entails the creation of a table that was used to analyze that data that provides a general summary of references, the problem that is being addressed, a solution that is being proposed, and the study's limitations. Data analysis is meant to assist in the system requirement process.

### **3.1.5 Ethical Consideration**

Acknowledge the authors' work utilized in any part of the dissertation using APA 7 as per Nelson Mandela African Institution of Science and Technology dissertation and thesis standards.

The willingness of respondents to take part in the study. In addition, participants had the choice to leave the study whenever they wished.

Participants provided their informed consent to participate. For people to fully understand the implications of participating and make an informed, deliberate, and freely given decision about whether or not to participate, without any pressure or coercion, researchers must provide sufficient information and assurances about participating.

The respondents' privacy and confidentiality were paramount when creating the questionnaires, interviews, and focus group questions. Offensive, discriminatory, or other undesirable wording was also avoided.

The highest level of objectivity was upheld in discussions and analyses throughout the investigation.

## **3.2 Materials**

The hardware used includes an ESP32 Microcontroller, flow sensor, solenoid valve, and buzzer, the major hardware components. The software consists of Embedded C, source coder editors, and Arduino IDE.

**Table 2: The ESP32 comparison with other Single-Board Computers (SBC's)**

Characteristics	ESP8266	ESP32	Arduino Uno
Microprocessor	Xtensa Single-core 32-bit L106	Xtensa Dual-Core 32-bit LX6 con 600 DMIPS	ATmega 328P
Wi-Fi(820.11bg/n)	HT20	HT40	No
Bluetooth	Does not have	Bluetooth 4.2 y BLE	No
Operating frequency	80 MHz	160MHz	16MHz
Flash	Not Available	16 channels	
GPIO	17	34	20
PWM (software)	Eight channels	16 channels	Six channels
SPI	2	4	1
I2C	1	2	2
Interface MAC Ethernet	No	Yes	Yes
Touch sensor	No	Yes	No
Temperature sensor	No	Yes	Yes
Hall effect sensor	No	Yes	No
Work temperature	-40°C to 125°C	-40°C to 125°C	-40°C to 85°C

The comparison of the ESP32 microcontroller with other single-board computers shown in Table 2 shows that the ESP32 and Arduino microcontrollers are the most commonly used boards in the market due to their features comparing their operating frequency. The features of General Input Output Pins and pulse width modulation (PWM) are the same. Despite the two microcontrollers having the same features, the ESP32 microcontroller is more efficient and reliable than the Arduino board because it has an in-built WIFI module, Bluetooth capabilities, and two I2C protocols.

Furthermore, the ESP32 can integrate various sensors on board, such as a temperature sensor, a touch sensor, and the most important sensor, in this case, a hall effect sensor that calculates the water flow rate. In conclusion, given all of the features and comparisons with other boards,

the ESP32 microcontroller is the most usable in this project despite being more expensive than the Arduino. It has features that are highly capable and essential to this project.

**(i) The ESP32 Microcontroller**

The Esp32 development board from Espressif is used for data collection from the sensors, actuation and communication. The board contains two Lower Xtensa of 32-bit LX6. For the booting process, the microcontroller has 448 Kbytes of read-only memory, which serves as data storage. The chip has 520 Kbytes of on-chip SRAM. The SRAM's main two functions are instruction memory, which is used for code execution whenever the code is loaded to the board, and data memory, which is used to store the data that has been processed. The board includes a WiFi module that can transfer data to the cloud or remote areas and is compatible with protocols such as the Message Query Telemetry Transfer protocol, which operates on the publisher-subscriber model.

The board can be integrated with security features such as WPA/WPA2 and encryption and decryption mechanisms. Furthermore, the board has various interfaces, such as UART, SPI, and I2C protocols, which are required for connection with various connectors. The operating temperature ranges from -40°C to +85°C, and the operating voltage ranges from 2.22 V to 3.6 V, requiring a voltage regulator to regulate the voltage of 12 V from the main power supply. Figure 5 shows the ESP32 microcontroller's internal part, which consists of various buttons and ports.

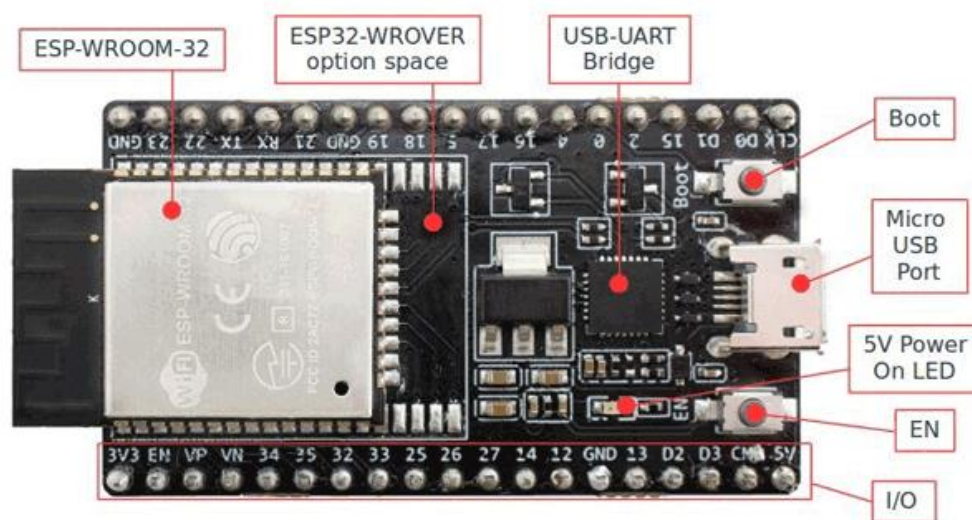

**Figure 5: Outer layout of ESP32**

Figure 6 shows the internal layout connection of the ESP32 microcontroller, which consists of the various General Input Output Pins (GPIO).

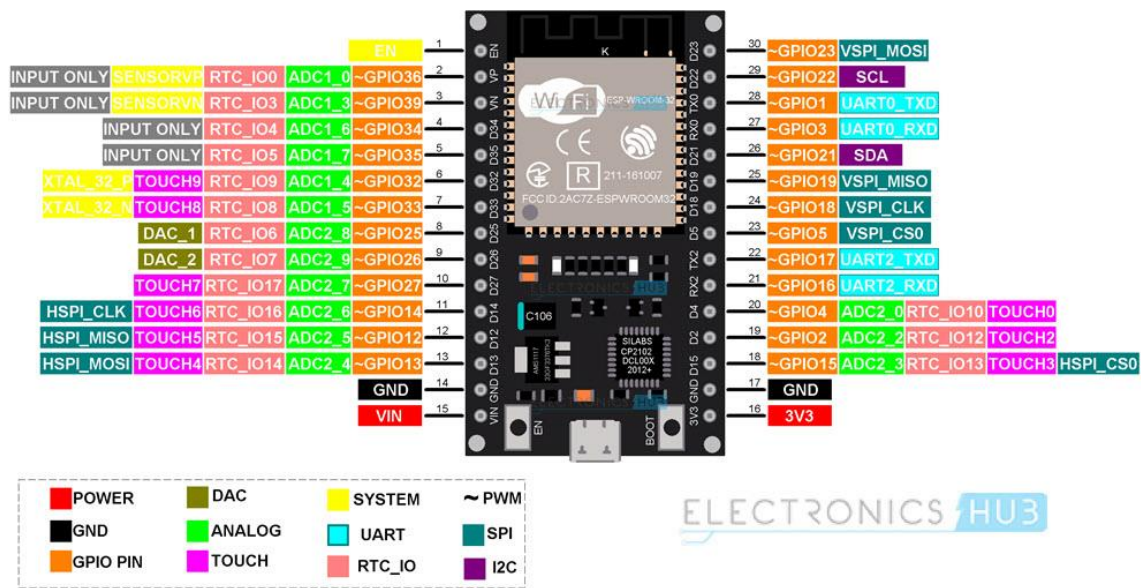

**Figure 6: Inner layout of ESP32**

**(ii) Water Flow Sensor**

Water flow in a pipe can be measured using this kind of sensor. The FY-201 sensor was designed and installed in this project on the pipeline, specifically in the water line. It measures the amount of water that passes through it. The magnetic hall effect sensor used in the sensor generates an electrical signal pulse after each rotation. To keep the sensor secure and dry, the water pipe has a seal around it.

The amount of water flow rate is determined by counting the number of pulses the magnet emits after each revolution. The sensor comprises the wire to which it is connected, representing the signal that will be used to communicate with the microcontroller. It consists of three wires: one red wire with a normal operating voltage of +5 V, one black wire that acts as a ground to reduce and prevent short circuits from the power source, and one yellow wire that acts as a signal. The yellow wire is used to output the signal to the microcontroller; this is the wire that connects the microcontroller's analogue pin. Water flow is determined and calculated by counting the pulse output by the sensor.

The pulse rate varies with flow rate, fluid pressure, and sensor orientation, and the pulse length is roughly 2.25 mm. The working voltage ranges from 5 to 18 VDC (min tested working voltages are 4.5 V), the working temperature ranges from -20°C to 80°C, the working humidity

ranges from 45% to 80% RH, and the maximum current draw is 15 mA (Jayapal, 2022). Figure 7 shows the FY-201 water flow sensor.



**Figure 7: The YF-201 water flow sensor**

### **(iii) Piezo Buzzer**

It is an electronic device designed to produce or generate an alarm or sound. It is usually lightweight, simple to build, and inexpensive. Buzzers are available in various sizes and specifications, with features that make them reliable. They can also be designed in various sizes based on various frequencies, resulting in various sound outputs. It consists of two wires, one black connected to the ground and one red connected to the signal, which is the microcontroller's pin. The resonance frequency ranges from 4.0 to 0.5 Hz, while the operating voltage ranges from 3 V to 16 VDC. Figure 8 represents the piezo buzzer.

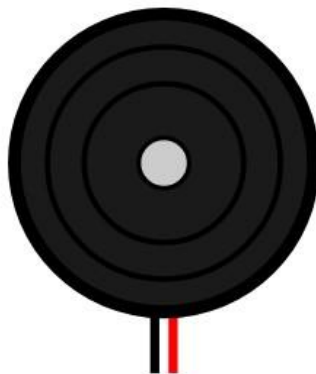

**Figure 8: Piezo buzzer**

### **(iv) Solenoid Valve**

In terms of water flow, this is a gravity-fed solenoid valve; the water flows directly from the overhead and requires zero pressure to open and close the valve, as shown in Fig. 9. In terms

of operation, it does not require the pump; however, if the pump is not cooperating, it will not function properly. When a 12 VDC voltage is applied to the two terminals, the valve will open and permit water to flow through the pipe even though it is normally always closed. It is designed so that water can only flow in one direction. An arrow shows the flow direction on the bottom of the valve (Palpandian *et al.*, 2021). Table 3 shows the specification of the gravity solenoid valve.

**Table 3: Specification of the gravity solenoid valve**

Current	250mA
Voltage	12V
Operation mode	Normally closed
Maximum size	84 x 53 x 41mm
Valve Type	Diagram (operated by servo)
Usage	Water and low-viscosity fluids



**Figure 9: Gravity solenoid valve**

### 3.3 Software Requirements

The programming language and software used to develop this system are part of the software requirements. The Arduino integrated development environment is a component of the integrated application software development system used to integrate and compile the C programming language to build the system.

### 3.3.1 Integrated Development Environment

Open-source software, known as the Arduino Integrated Development Environment (IDE), is used primarily for editing and uploading code to the Arduino board. Because it is open source and simple to install and compile the code, most Arduino modules are compatible with this software. The Java Platform, which is typically built with built-in functions and commands that are necessary for debugging, editing, and compiling code in the environment, is used by the Arduino Integrated Development Environment. This environment is compatible with various operating systems, including MAC, Windows, and Linux (Dahoud, 2018).

The Arduino Mega is the most popular and widely used module; other options include the Arduino Uno and Arduino Leonardo. The Arduino Mega has a flash memory of about 256kB, which allows it to load larger code and execute it more quickly than the Arduino Uno, which has 32kB flash memory. In terms of code execution, the code created on the Integrated Development Environment platform is known as a sketch, from which a Hex file is generated and transferred to the microcontroller. The microcontroller was an ESP32 board, and the IDE environment supported both the C and C++ languages used to develop the system. The IDE environment is divided into three major sections: the Menu Bar, the Text Editors, and the Output Panel. Figure 10 shows the three parts of the IDE environment.

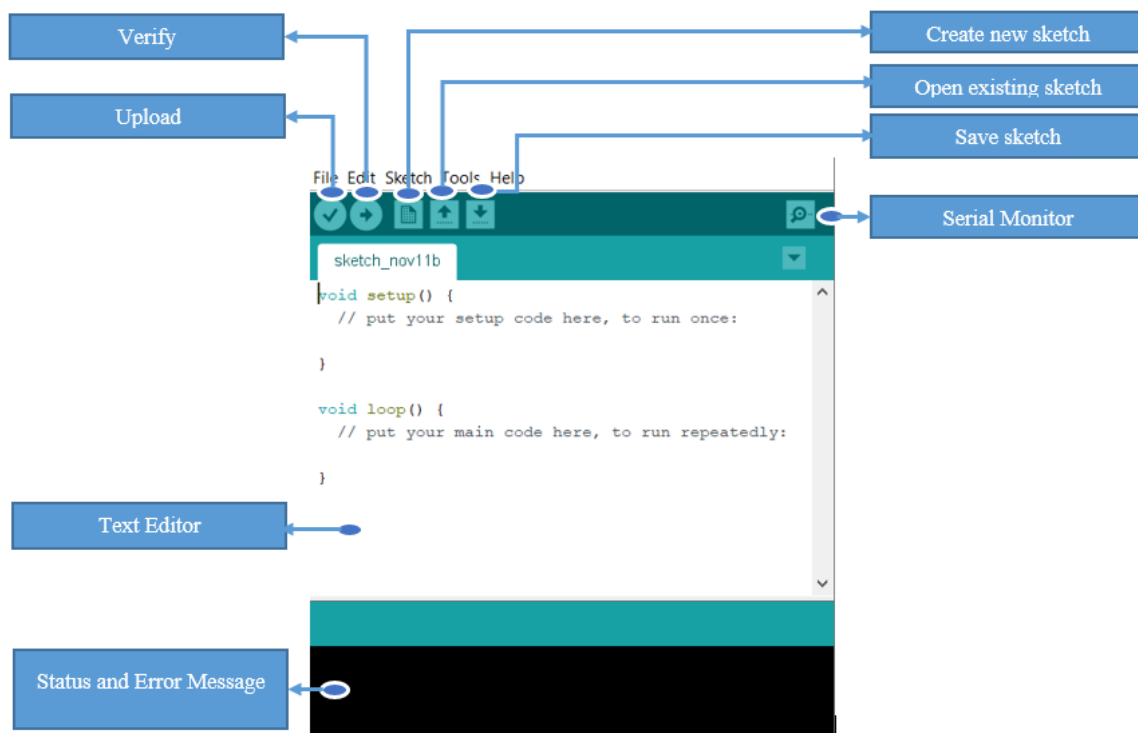

Figure 10: Screenshot of the Arduino IDE

### **3.4 System Development Approach**

The extreme programming approach, one of the agile methodology approaches, was used in this project. This approach was feasible because user requirements were created and met at each stage of development. During the development stage, users were incorporated, and every change requested was considered. Extreme programming was the best approach for this project because the software was tested as the project was being developed.

The essential elements of extreme programming that best suited this project are the essence of continuous revision of the program, whereby if there were any changes in the requirements, it would be adjusted and continue with the development process, and secondly, the element of short iteration, which involves delivering certain parts of the project to the user for any amendment within a specific time and making the necessary adjustment (Fojtik, 2011).

#### **3.4.1 Advantages**

The ability to improve code at any point during the implementation phase makes writing code simple. Developers can set objectives that produce results relatively quickly when the XP programming cycle is transparent, creating a platform for the overall process. In addition, compared to other methodologies, the entire software development process is agile due to ongoing testing at every stage of development.

#### **3.4.2 Disadvantages**

The user must be fully engaged in the process, which can sometimes interfere with development due to technical terms that the user is unfamiliar with.

Extreme Programming consists of fundamental activities: Planning, managing, designing, coding, and testing. Figure 10 depicts the extreme programming development cycle.

### **3.5 System Design**

Figure 11 depicts the extreme programming development stage, starting with planning, designing, developing, testing, and releasing the software to the market. During the planning stage, all requirements are gathered and analyzed. Next, the system is designed. Finally, the system is developed, and testing is carried out to ensure that it satisfies the requirements that were gathered and analyzed during requirements gathering.

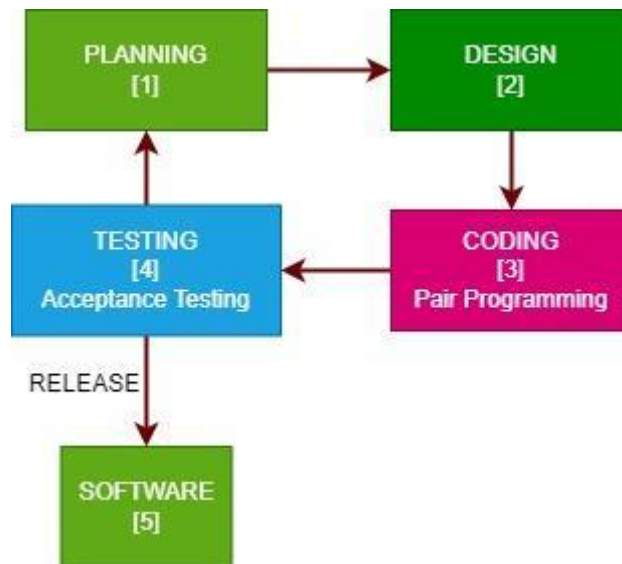
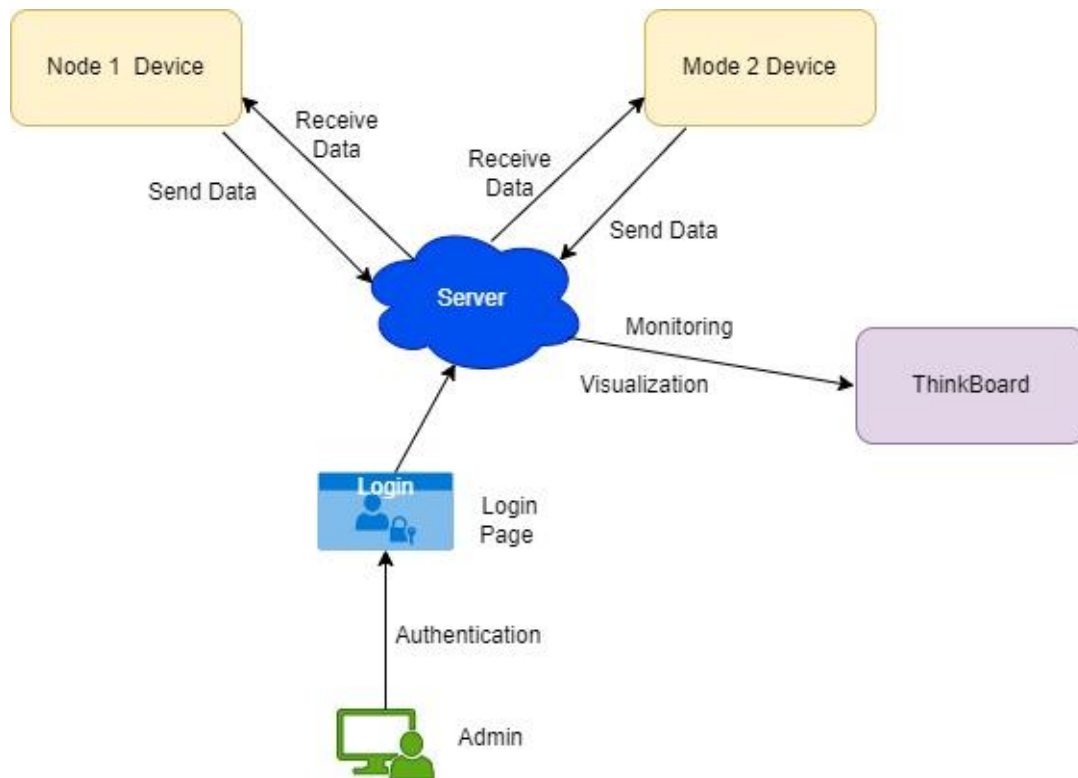

**Figure 11: Extreme programming development cycle**

### 3.5.1 Conceptual Diagram

The conceptual diagram presented in Fig. 12 shows how the system works. It shows how node one and node two interact with one another, communicating and sharing data. They exchange data via the server to centrally manage communication between two node devices. The ESP32 board serves as the microcontroller for the data processing and transmission to the server after it is processed by the water flow sensor, which measures the amount of water flowing through the pipe. The mode of communication and data transmission is WIFI/GSM, and the communication protocol is Message Query Telemetry Transfer (MQTT), which is based on the subscriber and publisher principle.

After the node one device at the source sends data to the server, the server communicates with the node two devices at the end of the tap to check if the amount of water received from the inflow sensor at the source is equal to that received by the node two devices at the tap. If there is a difference, the system will detect water leakages, and the two node devices will alert the microcontroller at the source. The system also includes a system administrator, the admin, who will log in to the system to monitor and control the water leakages remotely. This is accomplished through the Think Board, which the system administrator will use to view and manage the water leakages.



**Figure 12: Conceptual diagram**

### 3.5.2 Context Diagram

The context diagram presented in Fig. 13 depicts the interaction between the external entities of the Server, Thing Board, and admin. In this case, the admin logs in to the server using the username and password, and the server authenticates the admin to allow the admin to monitor and visualize the data. The admin can also remotely control the solenoid valve on and off, or the system will automatically close it.

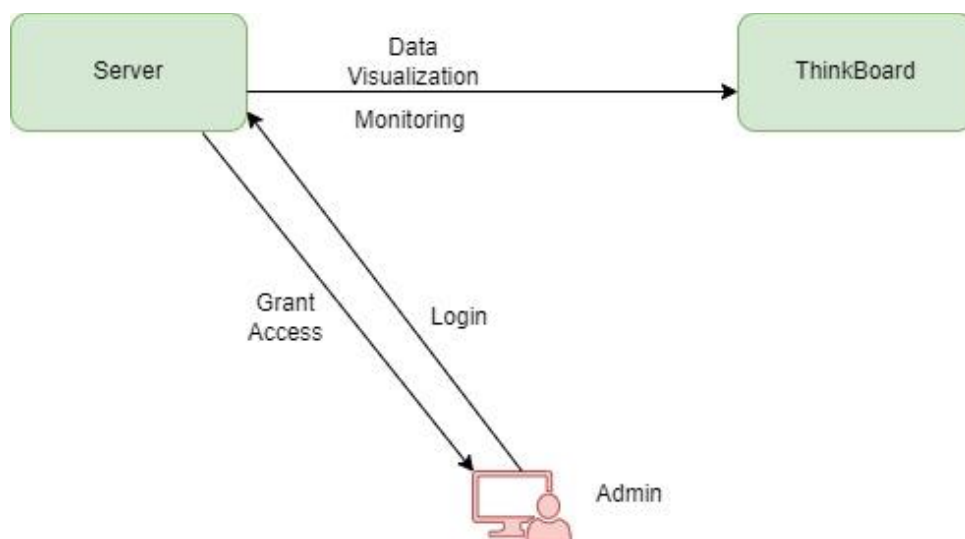

**Figure 13: Context diagram**

### 3.5.3 Block /Architectural Diagram

The architectural diagram of the industrial-based GSM water leakage detection, monitoring, and control systems in Fig. 14 shows various components connected. The first microcontroller in the diagram is located at the source of the pipe and is connected to an inflow water sensor to measure the amount of water. It is also connected to a solenoid valve to control the flow of the water; it can switch on and off the valve to regulate the flow of the water, and the buzzer is used to make an alarm or alert the authority that water leakages have occurred. At the other end of the pipe is another microcontroller connected to an outflow sensor, a solenoid valve, and a buzzer, and both devices are linked and communicate via the server. The transmission and data communication modes are WIFI/GSM and the Message Query Telemetry Transfer protocol (MQTT).

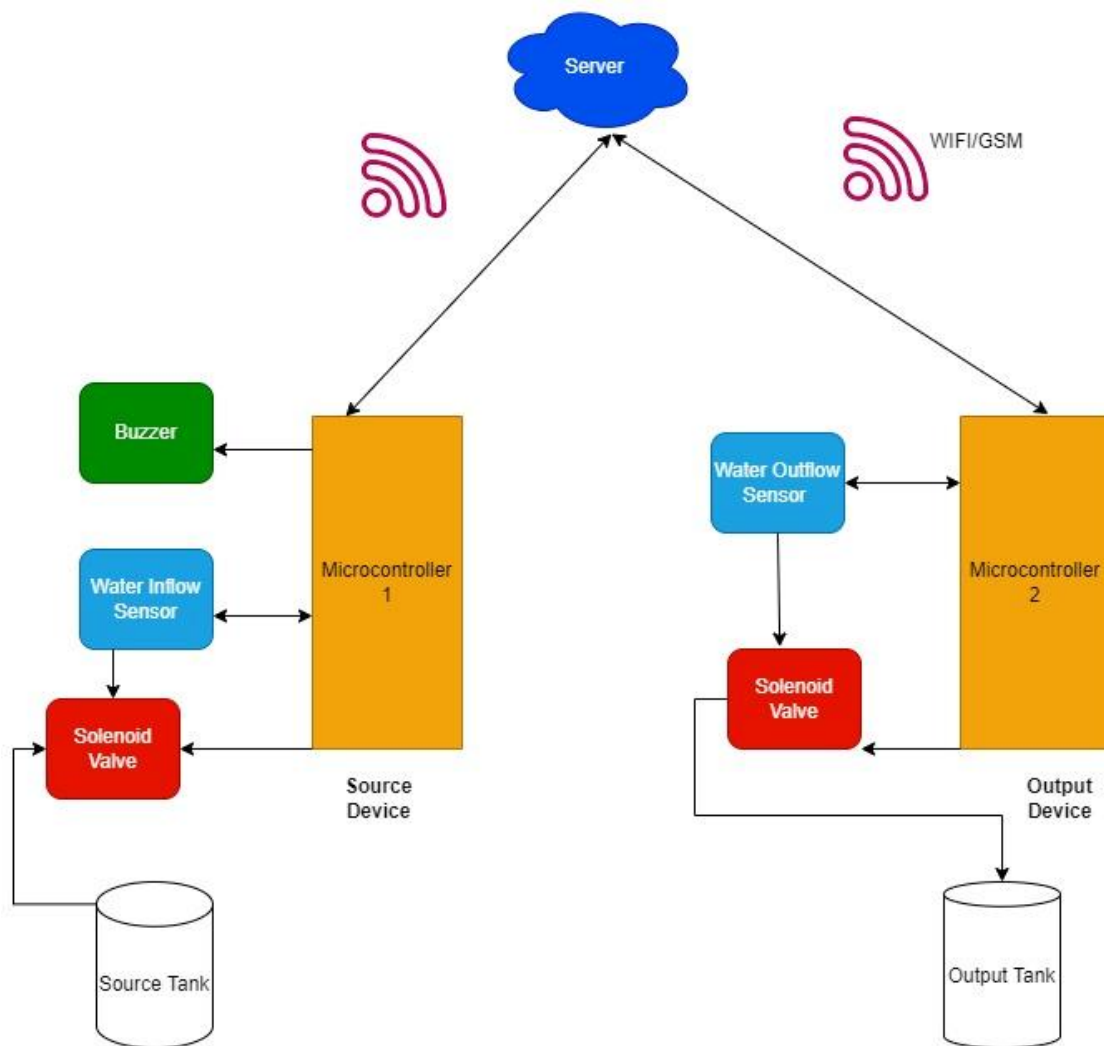

**Figure 14: Block /Architectural Diagram**

### 3.5.4 Flowchart Diagram

Figure 15 shows the flowchart of various processes happening in the system.

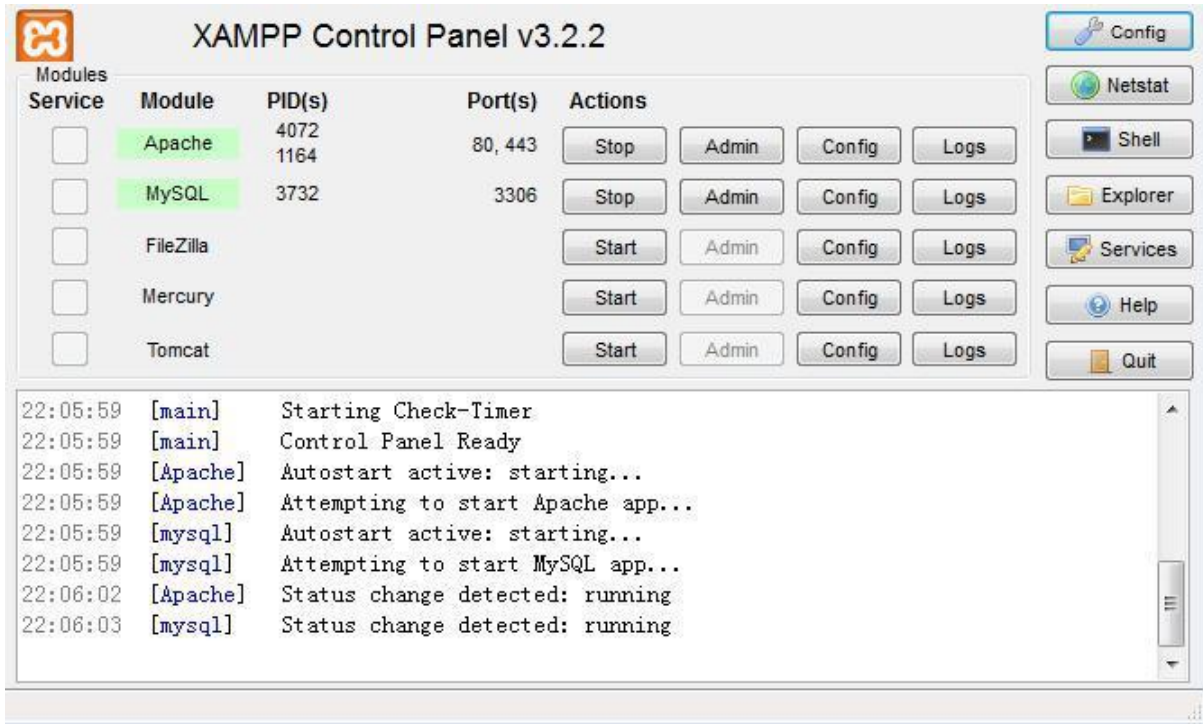

Figure 15: Flow chart diagram

### 3.5.5 Software and Hardware Tools Used

#### (i) The XAMPP

The acronym XAMPP stands for Cross-Platform Apache MySQL, PHP, and Perl. The HTML, PHP, CSS, JavaScript, and Cascading Style Sheet (CSS) codes were combined to perform various server-related actions, including creating, deleting, reading, writing, and opening. The XAMPP is used to control the status of the Apache and MySQL, as shown in Fig. 16.



**Figure 16: The XAMPP Control Panel**

**(ii) Proteus**

Proteus is a system simulator that lets you see the proposed system virtually (Veerasamy, 2015). It is a diagram of a printed circuit board in which various components are internally connected and run in virtual environments similar to the real world. The code written in the Arduino platform, which includes an integrated development environment, is imported to the proteus and loaded into the microcontroller. When the hexadecimal code is uploaded to the microcontroller, the system will operate in a virtual environment, just as it would in a physical one. Figure 17 shows the Proteus diagram representation.

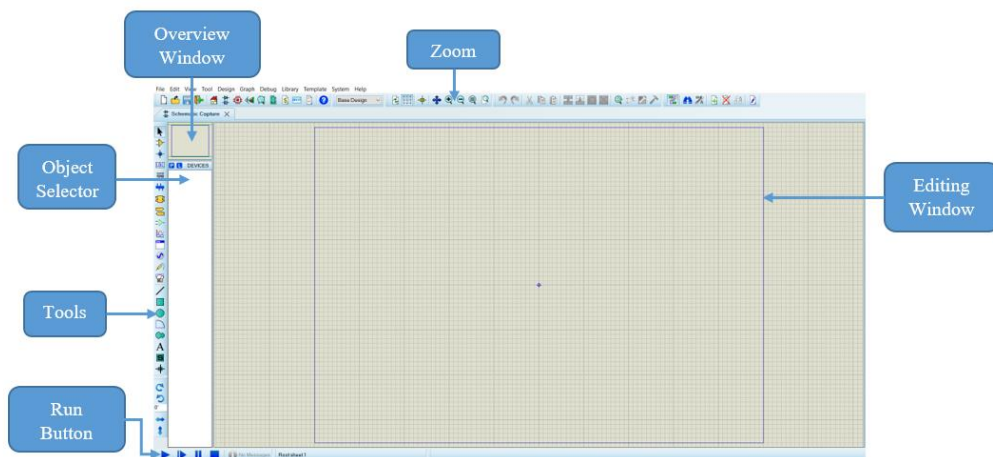

**Figure 17: Proteus diagram representation**

### **(iii) Things Board**

It is an open-source IoT platform that collects, processes, visualizes, and manages data. This project used IoT to ensure data flow from one device to another. Things Board allows devices to communicate with one another via a single server. The source and tap nodes communicated with each other via the server, which interacted with the Things Board via various communication protocols such as Message Query Telemetry Transfer (MQTT), Remote Procedure Call (RPC), and WIFI.

The communication technology is based on the subscriber and publisher principle, which states that one node subscribes to the topic by sending data from the node to the server. In contrast, the other node publishes the topic by receiving data. Communication between the nodes is accomplished through the WIFI capabilities provided by the ESP 32 microcontroller, as shown in Fig. 18.

Features of the Things Board that were appropriate for this project:

- Devices are controlled via a remote procedure call (RPC).
- Analyzing incoming telemetry with the trigger alarms generated by event processing.
- Facilitate data collection and visualization from devices.
- Provide devices, assets, and users and establish relationships between them.
- Customizing rule chains to enable use-case-specific features.

### 3.5.6 Things Board Architecture

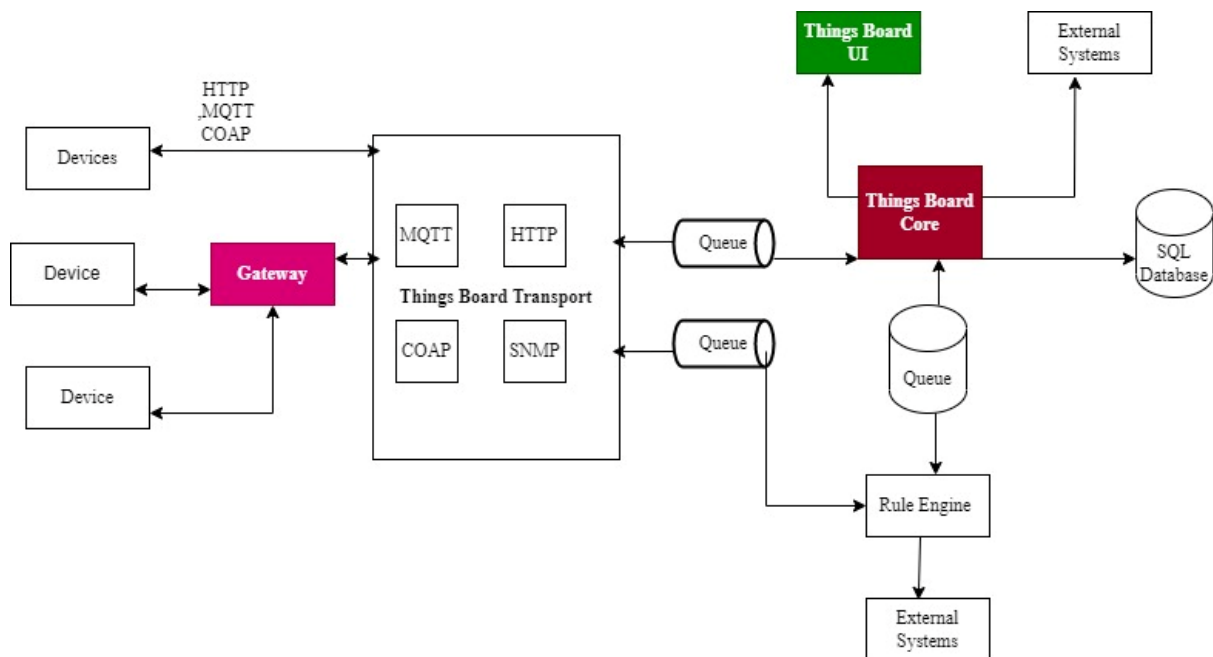

**Figure 18: Things board architecture**

#### (i) Things Board Transport

The application or firmware of the device offers Application Programming Interfaces (APIs) based on Message Query Telemetry Transfer (MQTT), Hypertext Transfer Protocol (HTTP), and Constrained Application Protocol (CoAP). Each of the protocols above is made available as a separate thing that is a part of the ‘Things Board’, in this case, the transport layer. In this case, MQTT serves as the Gateway. Gateways are special devices on the Things Board that serve as a link between externally connected systems on the Things Board.

The Gateway API allows data exchange between various devices and the platform through a single MQTT connection. The gateway also performs the function of a Things Board device, reporting statistics and receiving configuration updates using the current MQTT device API.

#### (ii) Things Board Core

The core of things Board's primary responsibility is handling REST API calls and web sockets. It is also in charge of keeping information about active devices up to date and monitoring the device's connectivity state. It employs the actor system, which can implement various actors for main entities, the platform requirements, and nodes that can join the cluster, each responsible for a specific aspect of the partitions of various incoming messages.

### (iii) Things Board Rule Engine

This is the system's heart and is normally in charge of processing incoming messages, which, in this case, are data from the nodes. The rule engine's internal actor system implements actors for central entities like rule chains and nodes. The rule engine can normally join the cluster, where each node is in charge of a particular function of message partitioning.

The rule engine always subscribes to the queue's incoming data feed and only acknowledges a message after processing it. In this context, many strategies are available that typically regulate the sequence in which messages arrive, are processed, and which message acknowledgement criteria are applied. The data sent from nodes and the server's processing strategies for the request sent by the two nodes are included in the submit strategies in this instance. The two operating modes for the Board of Things Rule Engine are typically isolated and shared. The Rule Engine processes messages or data from the various clients connected to the node. Only in isolated mode can the Rule Engine be set up to process messages for a particular client. The following topics are frequently used on the Things Board:

- `tb_transport.api.request`: To send generic API calls from transport to Things Board core to check device credentials.
- `tb_transport.api.response`: To transport device credential verification results from Things Board core.
- `tb_core`: Messages are sent to the Things Board core from the transport or rule engine.
- `Tb_rule_engine`: Messages are sent from the transport or rule engine to the Things Board core and then to the rule engine. Incoming telemetry, device states, and events were all included in these messages.

In general, the Things Board stores telemetry data and entities like devices, assets, customers, and dashboards in databases (attributes, time-series sensor readings, statistics and events). All entities and telemetry were kept in the SQL database.

### 3.5.7 Circuit Diagram

Figure 19 shows the circuit and how the components are arranged.

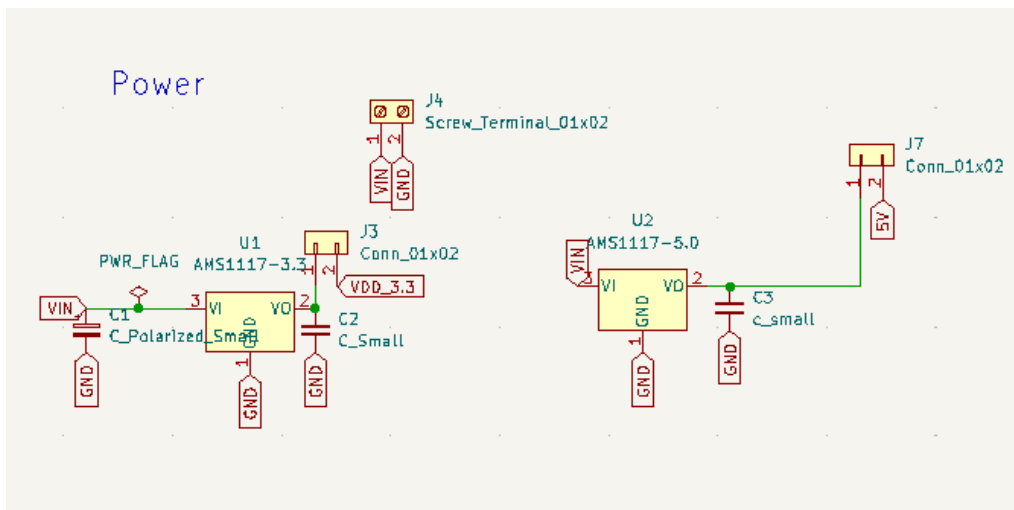

**Figure 19: Circuit of power design**

This is the power section design, which shows various parts of the power, such as the ground and working voltage of the ESP microcontroller, as well as various components connected, such as resistors and capacitors.

Figure 20 presents the various components of the ESP microcontroller design, such as the pin layout arrangement, which includes General Input Output Pins, Analogue Digital Converters, and I2C communication protocol with pins that are connected internally to the microcontroller.

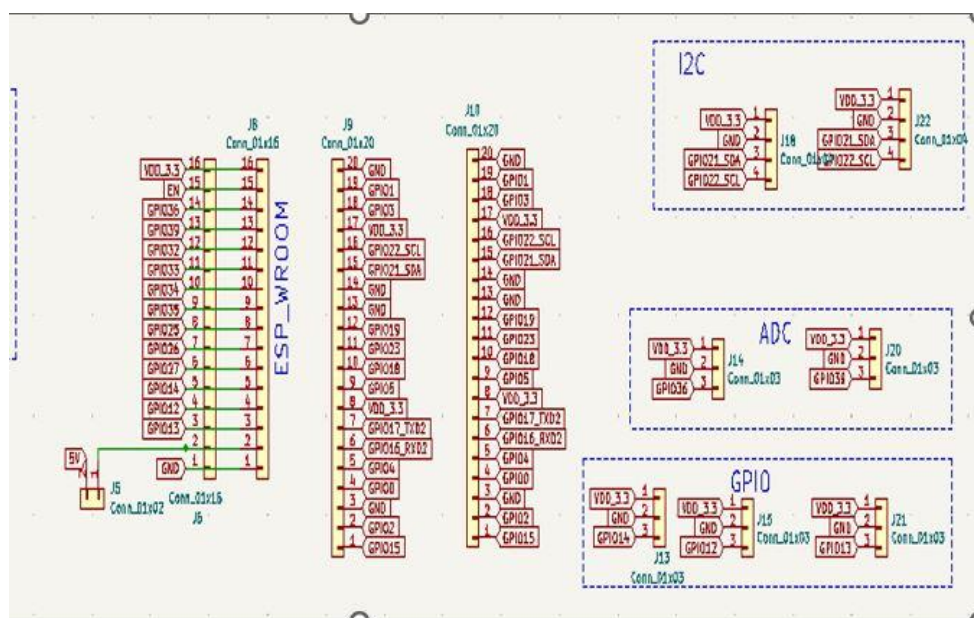

**Figure 20: The pin layout of the internal section of the ESP32 microcontroller**

### **3.5.8 Benefits of the Developed System**

#### **(i) Availability**

The developed system is available every time it is accessed; in this case, the water flow rate and volume of water are monitored in real-time and can be accessed at any time and from any location to check the volume of water. If there are any water leakages, the system administrator can turn the solenoid off and on to control the water flow.

#### **(ii) Use of the ESP 32 microcontroller**

This microcontroller has a wide range of features that are essential for use in industrial projects. It has a high-power processing unit, power management, and an in-built Wi-Fi module that allows communication with various devices to improve communication speed. With new technologies emerging, such as the Internet of Things, the ESP32 is the control unit.

#### **(iii) Technically Feasibility**

The system is technically designed where it is based on the client-server architecture that interacts based on the request-response mode, including the communication protocol that is the Message Query Telemetry Transfer (MQTT), where the various nodes interact together by publishing and subscribing to the topic, in this case, the data from the various sensors. The system is also feasible because it provides the user interface through which the user interacts with the system, which is the login page.

### **3.6 System Testing and Validation**

System testing is analyzing a system or its components to determine whether it satisfies the stated requirements or running a system to identify gaps and missing requirements in contrast to the actual requirements (Kumar, 2020). Various system testing procedures were carried out to ascertain whether the system complied with user requirements. The main testing phases were carried out using a systematic approach.

#### **3.6.1 Unit Testing**

It was carried out on a specific system module, determining whether the module was functioning as expected. The sensors from the two nodes were tested to see if they accurately measured the volume of water passing through them. The module that connects the server and

Things Board was tested to ensure that information sent from nodes is reflected to the server and that concurrent data is synchronized between two nodes and the server to reduce redundancy. This is followed by testing the system to ensure it provides valid input regarding the water flow rate display via the Things Board dashboard.

### **3.6.2 Integration Testing**

Two or more interconnected system functional units must be tested and certified for the system to function properly (Nidhra, 2012). Different operating units were tested to see if they worked together. This included integrating the unit of detecting water leakages in terms of the water flow rate between two nodes to work interdependently to ensure that the volume of water in terms of flow rate corresponded concurrently. The primary goal of integration testing is to improve data sharing between nodes and the facilitated communication mechanism.

### **3.6.3 System Testing**

This test was performed on the entire system to determine whether the functional requirements were met. The results show that the system works end-to-end in a production-like environment to meet the functional specifications in the high-level design (Nidhra, 2012). The system testing was used to understand the module's various functions, ranging from the integrated part of the system, which is the communication mechanism in terms of the protocol.

### **3.7.4 User Acceptance Testing**

User Acceptance Testing (UAT) is a type of testing that the end-user or client performs to verify or accept the system before deploying it to the production environment. The user acceptance testing was conducted to determine whether it met the user requirements. To determine the system's level or, more precisely, to provide a general evaluation of the system. The principal motivation behind this testing is to accept the end-to-end business stream. It doesn't concentrate on the vital blunders, spelling oversights or system testing. This testing is done in an isolated environment with a creation-like information setup. It is a discovery testing where two or more end clients will be included.

### 3.7 Requirements for the Proposed Industrial GSM-Based Water Leakage Detection, Monitoring and Controlling System

A requirement is described as a condition or capability that must be met or processed by a system or system components to satisfy a contract, standard, specification, or other formally imposed documents, according to the Institute of Electrical and Electronics Engineers (IEEE) standard 729.

#### 3.7.1 Functional Requirements

The functional requirements represent the tasks that the system must complete. It is what the system's end user anticipates receiving. Table 4 shows the various functional requirements of the developed system and their descriptions.

**Table 4: Functional requirements**

Requirement	Description
Detect water leakage	When water leaks occur, the system should be able to detect them.
Measure the volume of water.	The water flow sensor in the system should be able to measure the volume of water as it flows through the pipe.
Control the flow of water.	When water leaks are detected, the system should be able to control the water flow by turning on and off the solenoid valve.
Giving Alert	If a water leak occurs, the system should be able to notify the authorities. This is accomplished using the Things Board, an IoT platform for visualization.
Monitor the flow rate.	The system should be able to monitor the water flow rate, which is done using Things Board's real-time flow rate. The administrator must be able to monitor the flow rate in real-time.
Authenticate Admin	The system should be able to authenticate the admin to monitor and visualize data on the Things Board.

#### 3.7.2 Non-functional Requirements

These are requirements for quality that the system must meet. Non-functional requirements include security, maintainability, reliability, scalability, efficiency, and performance. Table 5

shows the system's non-functional requirements and describes how the developed system meets the non-functional requirements.

**Table 5: Non-functional requirements**

<b>Requirement</b>	<b>Description</b>
Security	The system should be secured, and only authorized users should have access to it.
Reliability	The system should provide precise information about the flow rate at each node, both at the source and destination nodes.
Increase Convenience	It should be very simple and easy to use.
Easy Maintainability	System updates and improvements should be simple to implement.
Consistency	The system should provide consistency in the water flow rate and volume of water in each water flow sensor.

## CHAPTER FOUR

### RESULTS AND DISCUSSION

#### 4.1 Results

Assessing demographic information is critical in gathering information required to develop system requirements. The primary data was obtained from the Eldoret Water and Sanitation Company employees responsible for distributing water to the surrounding town. The data obtained from the staff respondents are presented in this section. The data was collected based on factors required to determine the system's requirements. Gender, position in the company, experience, and the presence of water leakage problems were the factors considered.

##### 4.1.1 Gender Respondents During Questionnaire

Figure 21 depicts the gender distribution of respondents in this study. According to the graph, most of those who responded to the survey were male. As illustrated below, the male gender is higher with 69.2% than the female gender with 30.8%, particularly in the technical department dealing with water leakages on which this research was based.

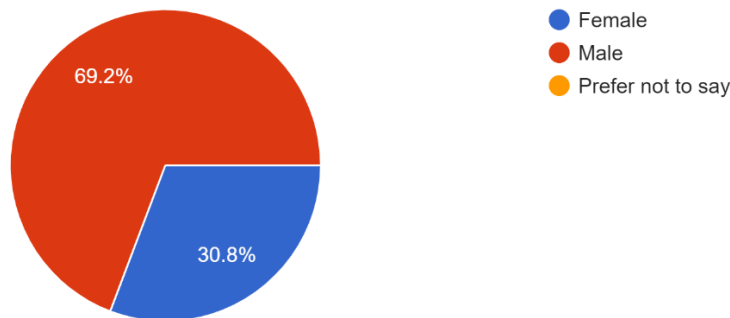

**Figure 21: Gender response pie chart**

##### 4.1.2 Staff Response from the Company

Figure 22 and Table 6 depict various personnel in the company and their positions. It shows that 15.4% of civil engineers responded to the survey, indicating that the research on water leakages is directly related to civil engineers, who are major players in detecting, monitoring, and controlling water leakages.

**Table 6: Responses from Staff**

Personnel	Number of Respondents	Percentage (%)
Artisan	1	7.7%
Civil Engineer	2	15.4%
Customer Relationship	1	7.7%
ICT Intern	1	7.7%
ICT Officer	1	7.7%
Non-Revenue Worker	1	7.7%
Senior Enforcement	1	7.7%
Technician	1	7.7%
Water Officer	1	7.7%
System Engineer	1	7.7%
Hydrologist	1	7.7%

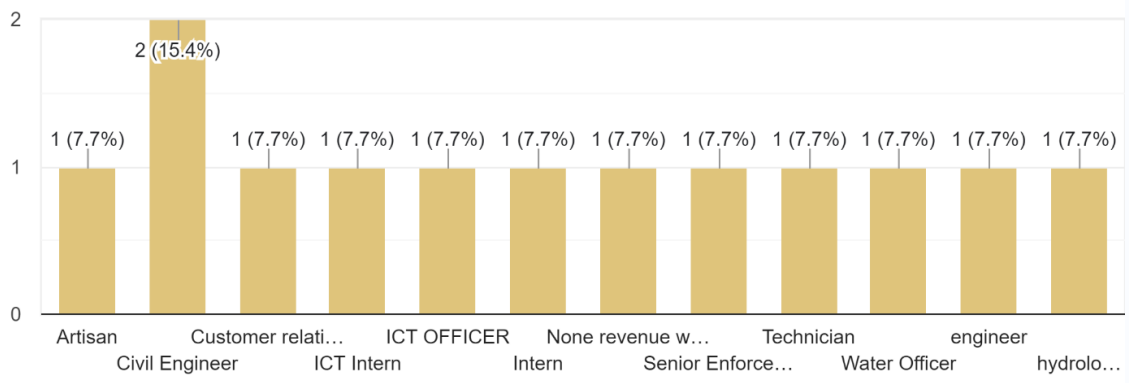
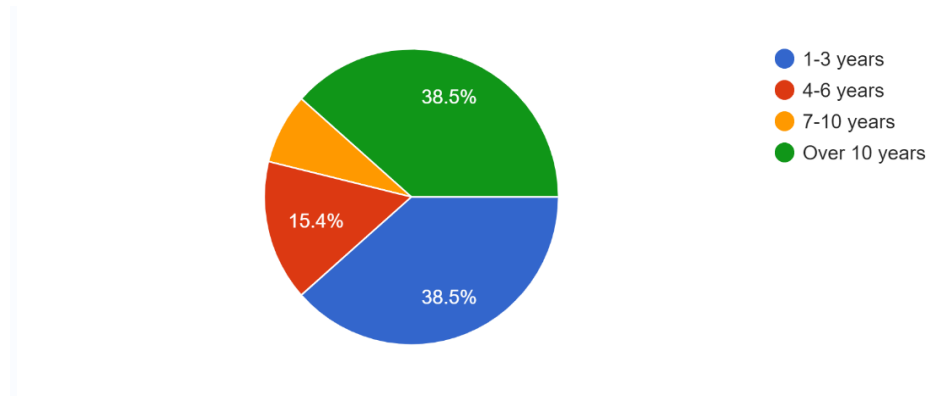

**Figure 22: Respondents distribution by category**

### 4.1.3 Years of Experience in the Company

Based on Fig. 23, the 13 employees' experiences, it is clear that those with more than ten years of experience have dealt with water leakage issues since their employment began. This highlights the need for a system to detect, monitor, and control water leakages. According to facts and statistics, employees with more than ten years of experience had 38.5%, while those with one to three years of experience had the same percentage. Employees with 1 to 3 years of

experience and over ten years of experience are among those who are truly responsible for water leaks, while those with 4 to 6 years of experience were 15.4%, and those with 7 to 10 years of experience did not include any employees, who made up 7.6%.



**Figure 23: Years of experiences**

Figure 24 depicts how respondents reacted to the issue of water leaks in which there was a significant issue with water leaks. According to the above data, the company needed extensive research to control the water leaks. All thirteen correspondents agreed that water leaks were the most serious problem in the company and that there was a need to develop GSM-based water leak detection, monitoring, and control systems. According to the collected data, Water leaks were a major hindrance for 100% of respondents.

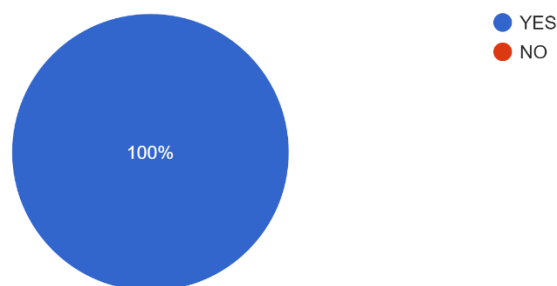
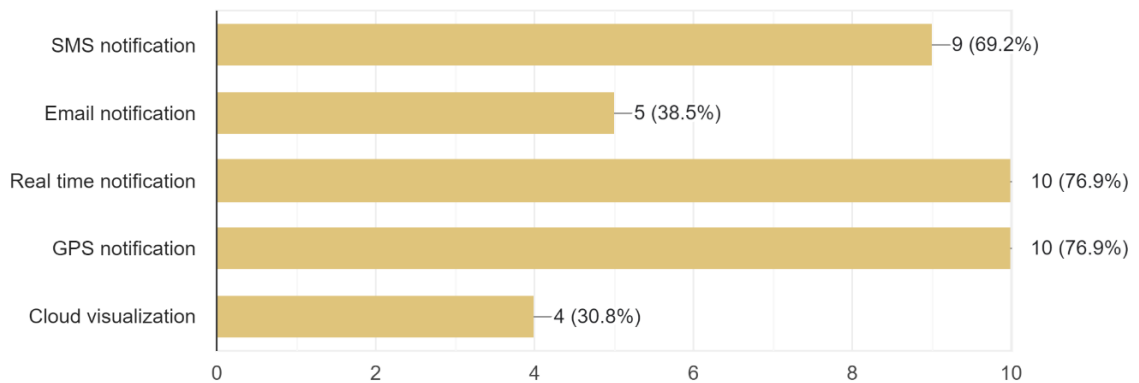

**Figure 24: Respondents on water leakages**

#### 4.1.4 Proposed System from Correspondents

Based on the research conducted, 76.9% of the correspondents proposed that the developed system incorporate the features of real-time notification and GPS notification, followed by SMS notification at 69.2% and email notification at 38.5%. According to the information, real-

time notification was the best feature to include in the developed system. The data is depicted in Fig. 25.



**Figure 25: User-proposed system features**

#### **4.1.5 Web-based Application**

The Hypertext Markup Language (HTML), Hypertext Preprocessor (PHP), Cascading Style Sheets (CSS), and JavaScript were the main tools used to implement this system. Figure 26 shows the login page designed using the abovementioned tools and software. The language used to develop the pages is PHP. One of the advantages of the language is that it is an open-source software that can be downloaded, installed, and used on the platform. The language is compatible with many browsers, especially Google Chrome, which is used in this system.

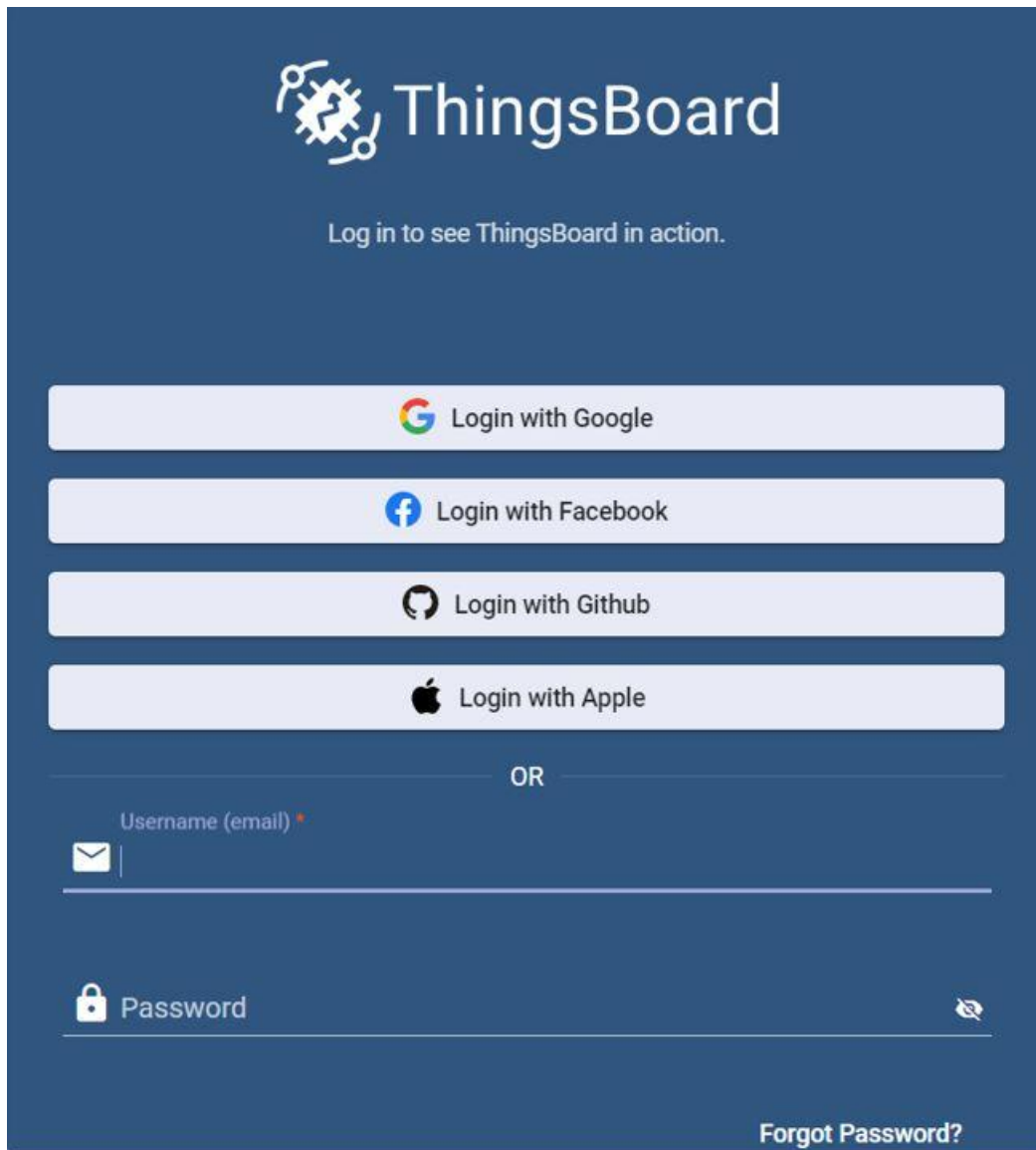

**Figure 26: The login page of Things Board**

**(i) User Authentication Unit Testing**

The sole purpose is to ensure that registered administrators can log in to the system without being denied by the system. The system, particularly the login page, was tested to ensure registered administrators can log in using their credentials. The test results are shown in Table 7.

**Table 7: User Authentication Unit Testing**

System Requirements	Results
Only registered administrators can log into the system with their username and password.	PASS
Only registered admin can recover their password via the system	PASS

**(ii) Dashboard for monitoring water flow rate**

Figure 27 displays the water flow rate at the water source on the dashboard as water flows from the storage tank through the source tap where the source node is located. The sensor measures the water's volume and flow rate as water flows through the source node.

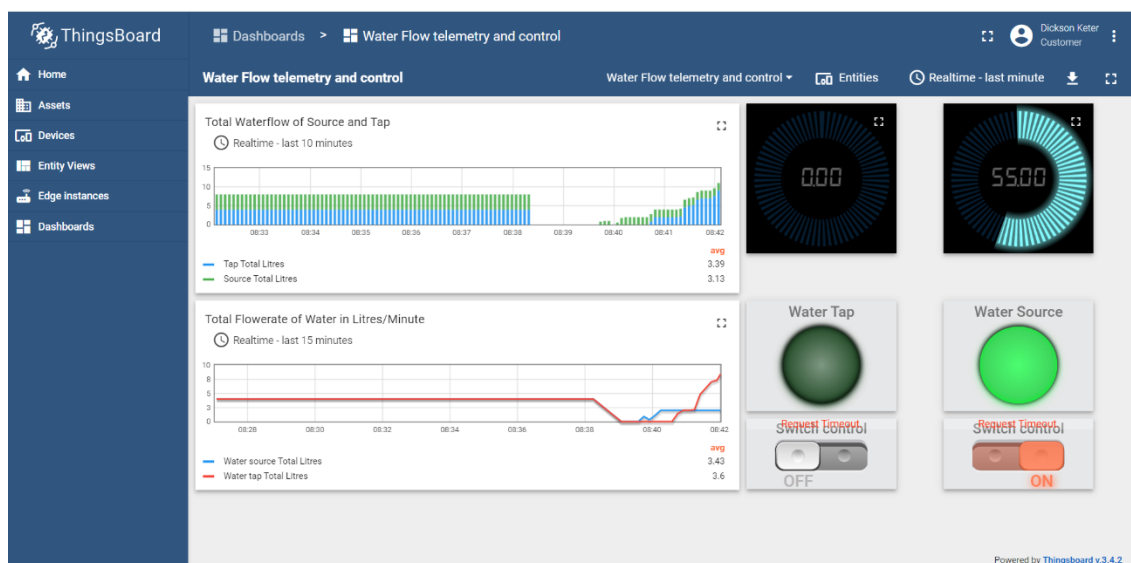

**Figure 27: Dashboard of Thing Board**

**(iii) Thing Board dashboard showing the total amount of water in the source and tap**

The monitoring dashboard is depicted in Fig. 27, which shows the total amount of water visible in both the water source and the water tap simultaneously. The illustration depicts the general monitoring dashboard, on which the water flow rate and the total amount of water flowing through the pipe were visualized in the Things Board. Water leaks were monitored in real-time, and the administrator could log into the system to control and monitor the leaks remotely and automatically as they occurred. Figure 28 shows the amount of water and the flow rate at each node, representing the source and water taps. When water leakage occurs, the two remote switches on the right-hand side of the Things Board dashboard control the water flow by switching off and on the valve at each node.

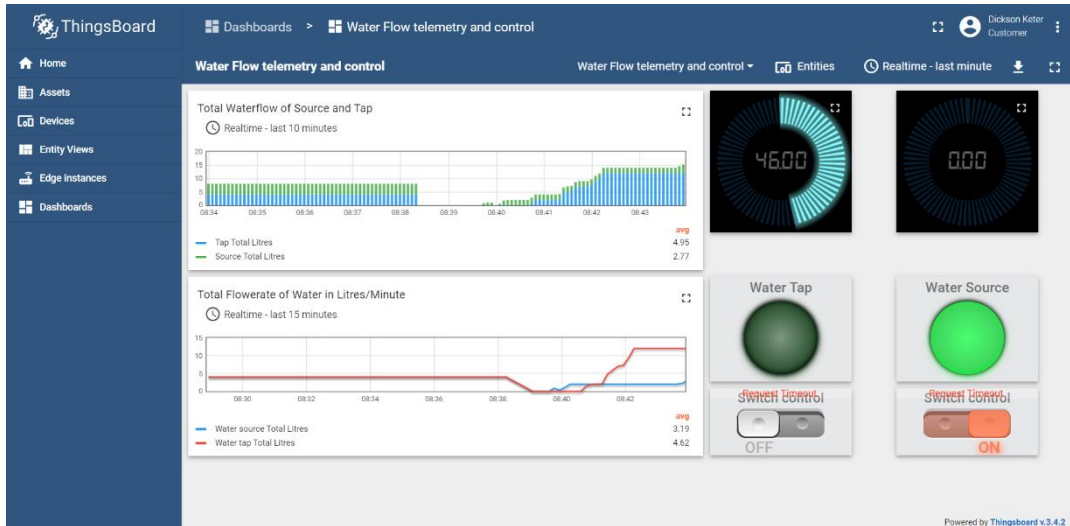

**Figure 28: Dashboard for controlling water Taps**

**(iv) Total flow rate and amount of water in taps**

Figure 29 depicts the water flow rate at just the water tap, with the water flow rates almost equal. Every moment, the water flow rate was observed; in this instance, the water flow rate was monitored for 15 minutes, from 0830 AM to 0845 AM.

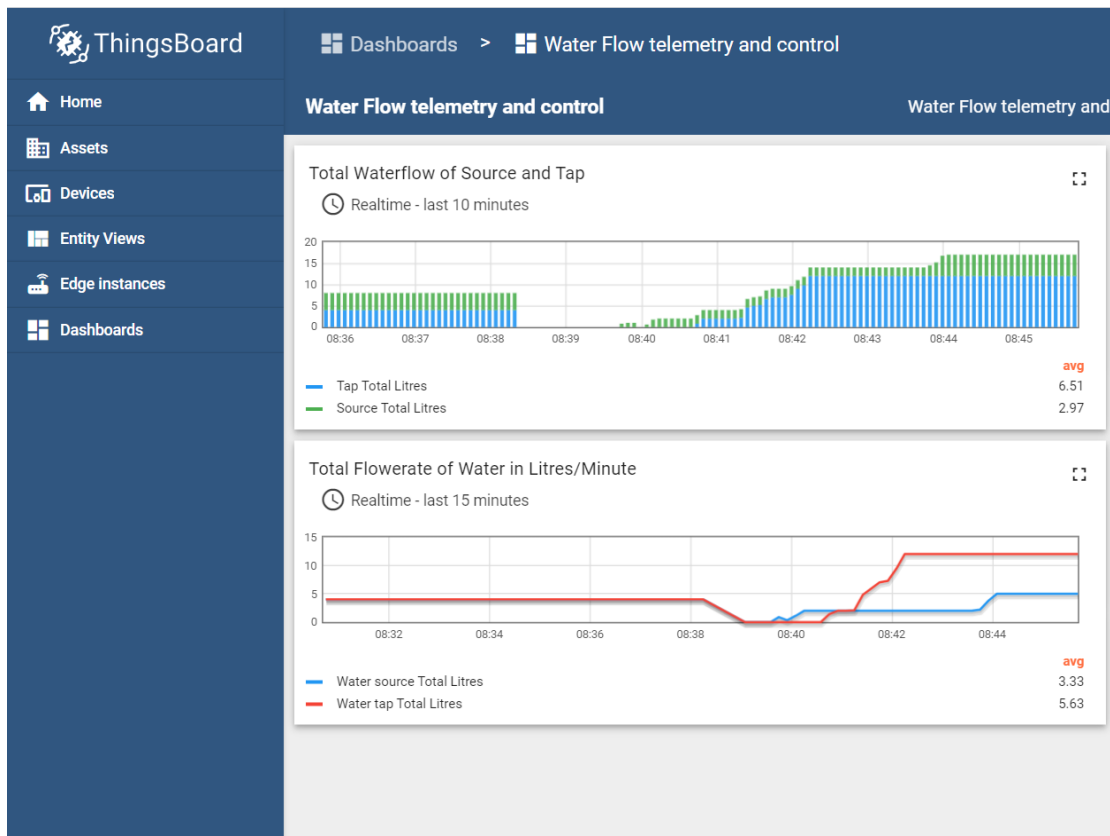

**Figure 29: Total flowrate and amount of water in both taps**

**(v) Water Flow Telemetry Control**

Figure 30 depicts the water flow telemetry control graph, which shows the total water flow at the source and tap nodes on the upper side and the total water flow rate in litres on both the source and tap nodes on the lower side.

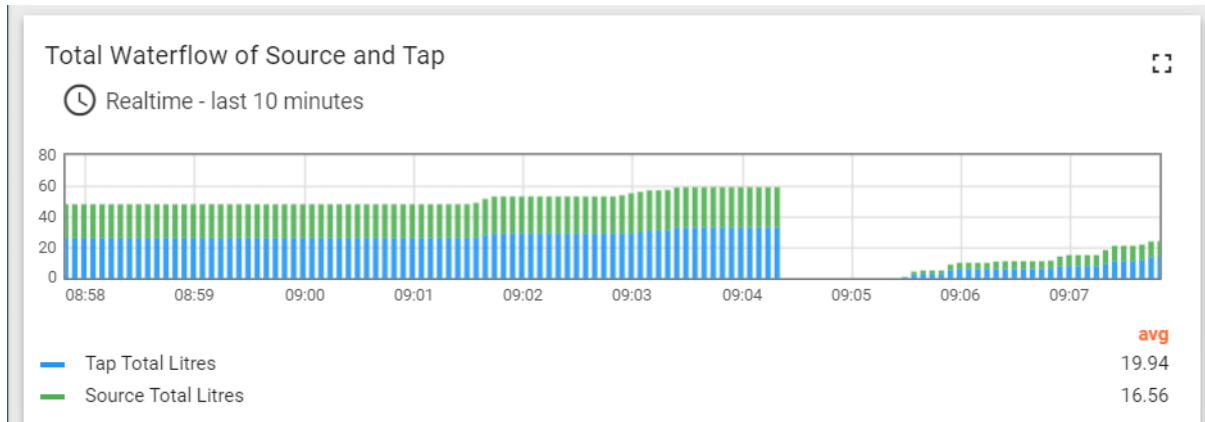

**Figure 30: Total amount of water in Source and Tap**

**(vi) Total Water Flow**

Figure 31 shows the graph of the total water flow in the source and tap. The total water flow in each node is approximately 20 litres in about 10 minutes from 0858 AM to 0907 AM.

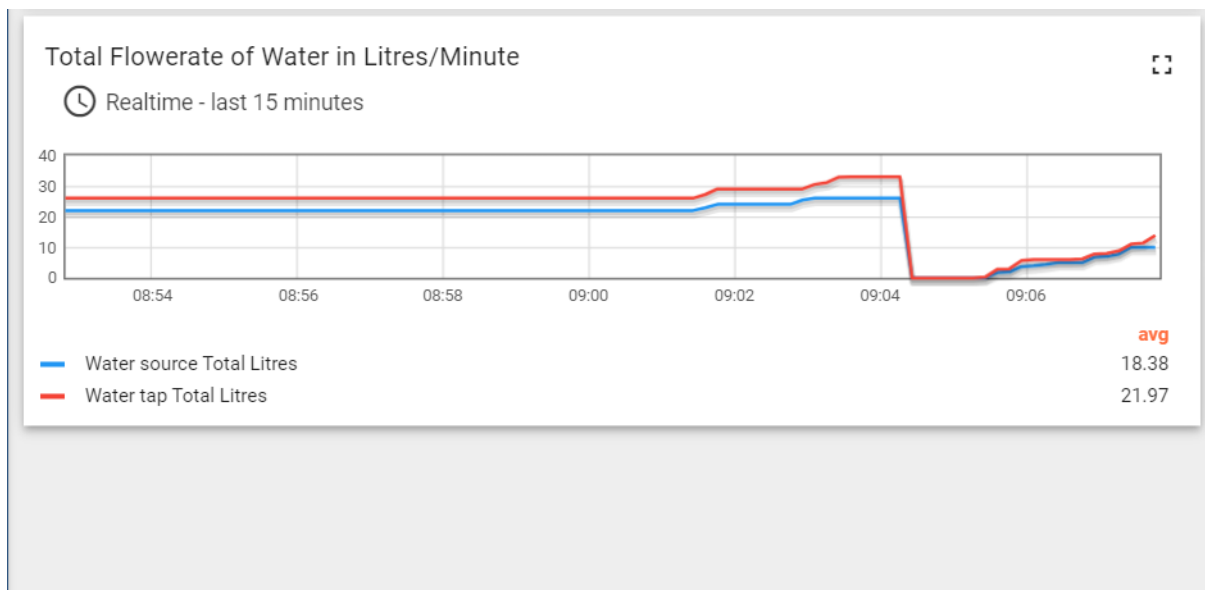

**Figure 31: Total flowrate of water in Source and Tap**

Figure 31 depicts the total flow rate of water in litres per minute. The flow rate was constant on both nodes from 0854 AM to 0904 AM and then decreased from 0904 AM to 0905 AM

before increasing again from 0906 AM to 091 AM. This flow rate was based on the real-time monitoring.

**(vii) Switch Control in Source and Tap**

Figure 32 depicts two nodes that display the water's flow rate in real-time and is used to track water leaks; as the water passes through the pipe, the two nodes record its flow rate and volume. Each node's water flow rate occurs simultaneously. When there is a water leakage in the system, it can be controlled remotely by closing the water valves because the flow of the water is monitored in real-time by the administrator.

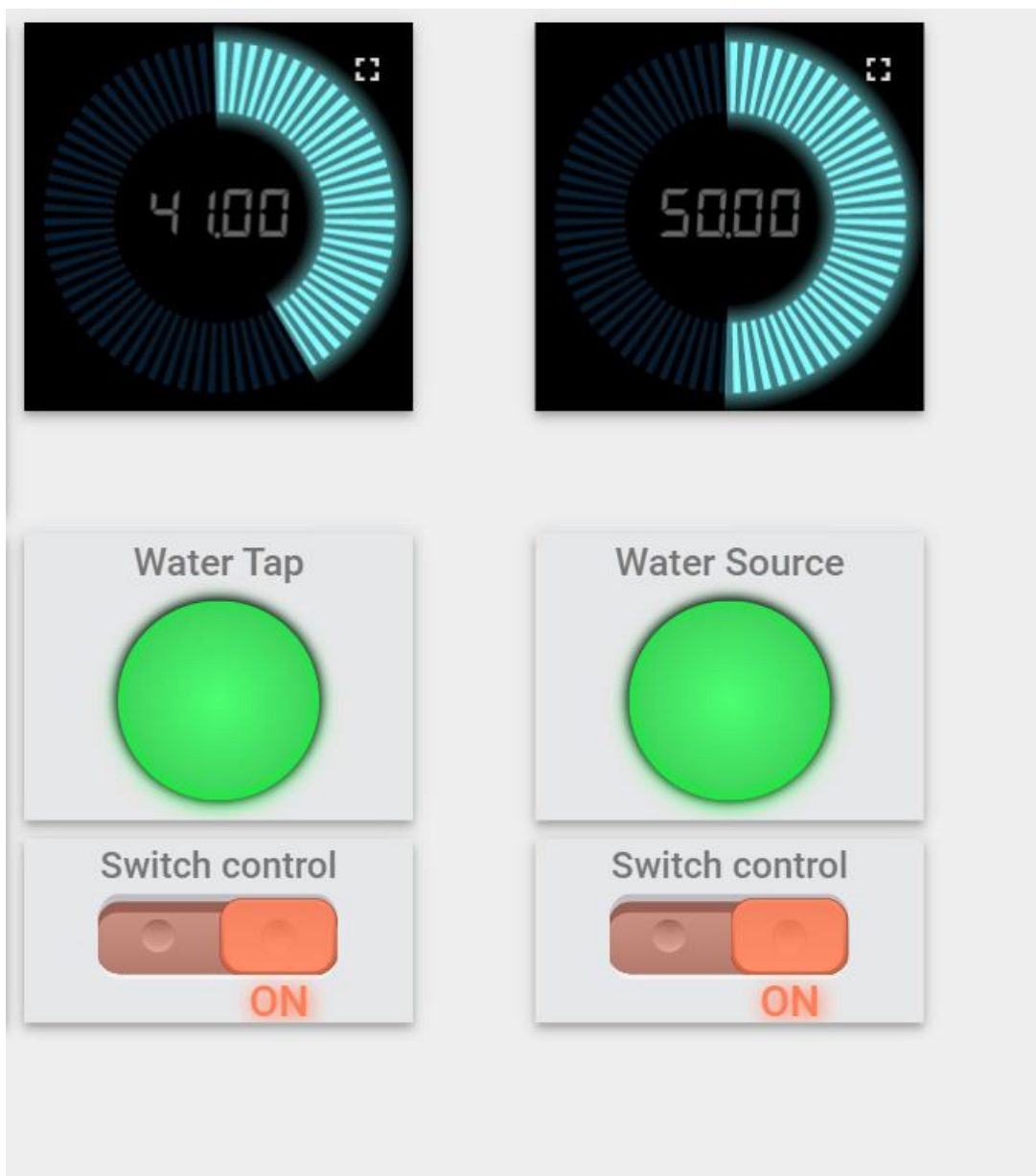

**Figure 32: Control Switches as Source and Tap**

#### **4.1.6 The Working of the System**

The industrial-GSM water leakage detection, monitoring, and controlling system is a real-time monitoring system that detects and controls water leaks from the source to the destination tap. At the source is a node comprising an ESP32 microcontroller, a water flow sensor, a solenoid valve, and a buzzer, all linked together to facilitate communication. The water flows through the pipe toward the destination tap, which acts as the outlet; in normal circumstances, the water flows in the pipe without leakage at the destination tap; there is also the node, which is composed of the ESP32 microcontroller, water flow sensor, solenoid valve, and buzzer are the major components in this project. The purpose of the microcontroller is to control all the components connected to it; the type of flow sensor used in this case is the YF-201 flow sensor; it measures the flow rate of the water; as the water flows through the sensor, the rotor inside the sensor rotates by making the number of revolutions per unit time, in this case, the unit used is microseconds, to calculate the flow rate of the water passing through the sensor, it is calculated as the number of the revolutions per unit time in this case. In the event of a leak, a solenoid valve was used to control the flow of water from the source to the destination, while a buzzer was used to act as an alarm for notification.

The system consists of two nodes, one in the source tap and another in the destination tap, which can communicate with each other via the server. Two sensors at the source and destination measure the volume of water in normal conditions. If the two sensors have the same volume of water, the two nodes communicate to determine whether there is the same amount of water in both nodes. If there is a slight difference in volume between the nodes, they will communicate with the server to determine what action to take. The necessary precautions are to send a command to the microcontroller to turn off the solenoid valve that controls the water flow. When the water flow exceeds a certain threshold, the system triggers the microcontroller, which turns off the solenoid to control the leakage and alerts the authority via the buzzer alarm for the necessary action. Because the system is a real-time monitoring system that can be monitored remotely and controlled while away from the premises as well as while on the premises if a water leakage occurs, the system can detect and control it automatically and remotely via the IoT platform used for real-time visualization and monitoring to prevent further leaks.

#### **4.1.7 Communication Mechanism**

WI-FI allows two nodes to communicate with the server. The source node initiates communication by sharing data from the flow sensor with the destination node via the server. The mode of communication protocol is Message Query Telemetry Transfer (MQTT), which operates on the subscriber and publishing principle. In this case, the source node publishes the data collected from the water flow sensor concerning the volume of water measured. In contrast, the destination node subscribes to the topic in this matter, which is the volume of water measured by the source node and compared to its volume of water measured. If the volume of the water in both nodes is the same, nothing will happen; if the volume in both nodes differs, the destination node will publish the information to the server, while the source node will subscribe to the data published by the destination node. The server will then send an event to both nodes, instructing them to turn off their solenoid valves, which control the water flow.

Thing Board, an IoT platform for real-time monitoring and visualization, communicates with the server, allowing the administrator to visualize the real-time flow of water in terms of flow rate in both nodes. The system administrator logs into the Things Board to monitor the flow rate of the individual nodes remotely without being physically present on the premises to monitor the water leakage. Administrators can remotely turn on and off solenoid valves without being physically present.

#### **4.1.8 System Implementation Overview**

##### **(i) Source Node**

Figure 33 depicts the FY-201 water flow sensor, which measures the amount of water passing through it. The solenoid valve regulates water flow through the pipe, and the ESP32 microcontroller, which controls all of the components connected to it, makes up the source node subsystem. When the system detects water leakage, the server triggers the microcontroller at the source to close the water, and the microcontroller initiates a command to the solenoid valve to switch off.

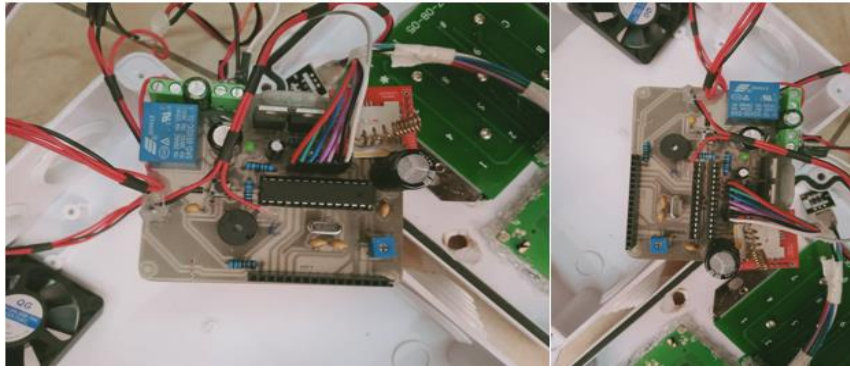

**Figure 33: Source Node Subsystem**

**(ii) Destination/Tap Node**

Figure 34 depicts the tap node located at the end of the piping compared to the source node. The node operates similarly to the source node and comprises three main components: an ESP 32 microcontroller, a water flow sensor, and a solenoid valve. Both nodes operate concurrently via the server; in the event of water leakage due to water volume differences, the two nodes communicate via the WI-FI connection enhanced by the microcontroller via the server, and the system automatically switches off both solenoid valves at the source and tap. The System administrator logs in to the Things Board to view the live data stream and control the valves remotely.

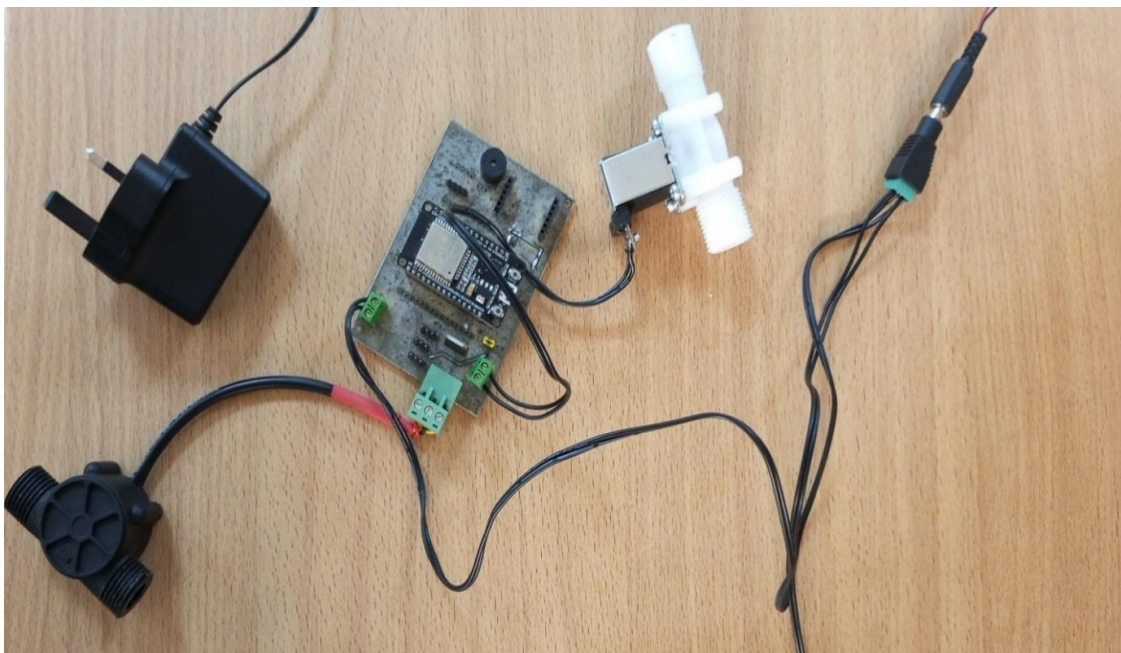

**Figure 34: Destination/tap node subsystem**

The integration of the source and destination subsystems in Fig. 35 facilitates communication between the two nodes.

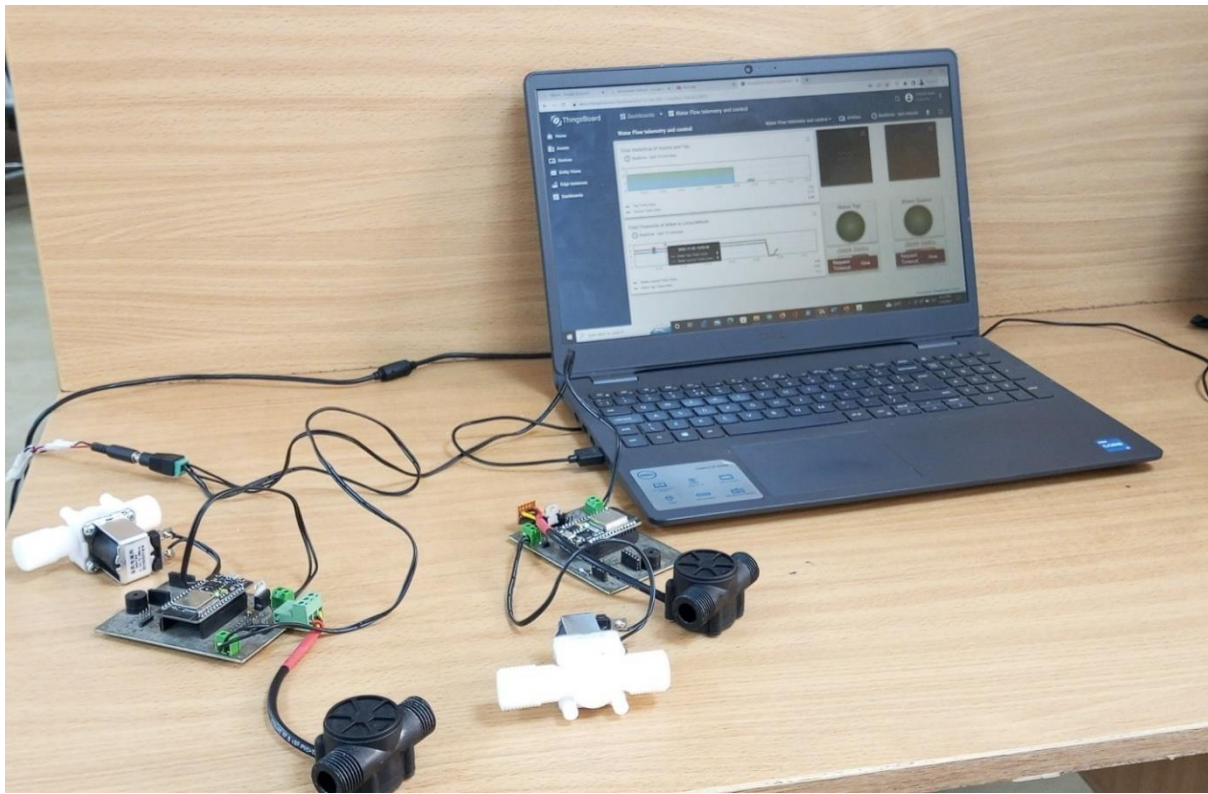

**Figure 35: Integration of source and destination subsystem**

#### **4.1.9 User Acceptance Testing**

User Acceptance Testing (UAT) is a type of testing that the end-user or client performs to verify or accept the system before deploying it to the production environment. The user acceptance testing was conducted to determine whether it met the user requirements. To determine the system's level or, more precisely, to provide a general evaluation of the system in terms of performance, efficiency, reliability, ease of use, and usefulness, participants in the system verification and validation were incorporated into the testing process by responding to questionnaires. The responses are listed in Table 9.

Table 9 displays the user responses. It reveals that 33.33% and 66.67% of respondents strongly agreed or agreed with each other, respectively, indicating that the system complies with the requirements. The 91.67% and 8.33% strongly agree and agree, respectively, indicating that the system was simple. In comparison, 50% and 41.67% strongly agree and agree, respectively; 83.33% and 16.67% of responses indicate that the system is efficient.

**Table 8: User Acceptance Testing**

Questions	12 responses				
	Strongly agree	Agree	Not Sure	Disagree	Strongly Disagree
The system works according to the requirements	33.33%	66.67%	-	-	-
System reliability and scalability	50%	41.67%	8.33%	-	-
System efficiency	83.33%	16.67%	-	-	-
The system is easy to use	91.67%	8.33%	-	-	-

## 4.2 Discussion

According to the project’s findings, the system that has been developed will be extremely important to water service providers because it can be used for real-time detection and monitoring of water leaks. The system can be installed by water service authorities to help with water leakage detection. Based on user feedback and results, it is clear that water leakage is a major issue for water service providers, and they need a system to assist them in doing so. As a result, the development of this system will be of greater significance to the water services company. The creation of a real-time water leakage detection, monitoring, and control system will be integrated with other water leakage systems already in place to improve their efficiency, such as when water leaks are reported to the appropriate authorities via SMS.

The developed system satisfies the participant's expectations regarding user acceptance testing recommendations based on their provided information. The outcome of the acceptance testing shows that the system complied with user expectations. The system effectively enabled real-time monitoring of water leaks; scalability was also regarded as crucial for integration with other integrated systems, such as billing systems for revenue collection. The system was also easy to use because the user needed to monitor the water flow in real-time and remotely control it without interacting with it physically to log into the system, specifically the Things Board.

## CHAPTER FIVE

### CONCLUSION AND RECOMMENDATIONS

#### 5.1 Conclusion

The real-time industrial-based-GSM water leak detection, monitoring, and controlling system consists of two nodes: one at the source and one at the destination or tap. It comprises various sensors and a solenoid valve that controls water leakage. The developed system could monitor water leakages in real time, with the two nodes interacting by sharing information via the server and communicating via the Wi-Fi enabled by the ESP32 Microcontroller.

The engineer remotely monitored the information to view the water flow rate via the Things Board, an IoT platform used to visualize real-time data generated by various connected devices. Furthermore, within the company premises, the system was able to detect water leaks in real-time, which benefited the company because the issue of the non-revenue collection was reduced, and the company was able to monitor the flow of water from the source, which was the reservoir, to the distribution networks. This indicates that the system met the project goals of detecting and controlling water leaks in real time.

While the developed system met the design capabilities in terms of technical aspects, functionality, and specification for the proof-of-concept system, some things will change in the future for the system to work properly and efficiently in terms of detection, monitoring, and controlling the user interface, which is the interaction between the server and Things Board that is to be more interactive and simpler. This project's FY-201 water flow sensors demonstrate that advanced systems can be developed using simpler and more sophisticated sensors for greater accuracy and precision. Furthermore, using Wi-Fi to communicate between the two nodes only covered a short-range distance of 80-100 meters. Furthermore, using the ESP 32 microcontroller as the control unit for all connected devices was critical in terms of the features that support wireless connectivity and processing power. With new technological trends, such as the Internet of Things, these microcontrollers will facilitate faster adoption in industrial projects.

Because of the rapid growth in internet access in various sectors, including agriculture, health, and education, which has resulted in automation as a result of data-driven technology, the

development of a real-time industrial GSM-based water leakage detection, monitoring, and controlling system is of great assistance in this arena of automation.

The system provides numerous benefits to Eldoret water service providers and university researchers. Eldoret water management will be able to monitor water leakages in real-time, which will aid in reducing non-revenue collections because the developed system will be able to detect water leaks. It will be of great importance to university researchers to advance their study in the field of water leakages and provide better, more efficient, and dependable solutions to water service providers impacted by water leakages. The systems have numerous advantages over traditional SMS notifications of water leaks. Among these benefits are:

- (i) The system administrator's ability to control the system remotely without physically switching on and off the solenoid valve.
- (ii) The overall cost of system development is lower when compared to SMS, which requires monthly subscriptions, whereas the Things Board can only be accessed using the server via Wi-Fi.
- (iii) The system can be installed in hazardous areas such as valleys and mountains, which can endanger human life.

## **5.2 Recommendations**

A real-time industrial GSM-based water leakage detection, monitoring, and controlling system was created for the company to monitor water leaks. Due to time and scope constraints, the system was developed to monitor water leaks in the main pipe that connects the water reservoir tank to the destination end-point. This research concentrated on the water along the main pipe, which lowers the overall cost due to the complexity of the water in distribution networks, which sometimes requires many sensors.

A further challenge is determining the precise flow rate of the water passing through the pipe, which is brought by the calibration of the YF-201 flow sensor, which typically differs sometimes due to the pressure difference resulting from the flow of the water from one channel to another. Because the developed system did not address that specific issue of the water at the distribution network, most likely due to time constraints and the project scope, the research only focuses on the water along one channel. Further research must determine the water flow sensor's precise calibration factor despite pressure differences.

However, it suggests that future researchers concentrate on this as their problem statement shortly to develop systems capable of finding water leaks in distribution networks that are both dependable and economical. Second, more investigation into identifying leaks at particular points along water pipes should be suggested by integrating with the Global Positioning System (GPS) to determine their precise location.

## REFERENCES

- Al Qahtani, T., Yaakob, M. S., Yidris, N., Sulaiman, S., & Ahmad, K. A. (2020). A review of water leakage detection method in the water distribution network. *Journal of Advanced Research in Fluid Mechanics and Thermal Sciences*, 68(2), 152–163.
- Bhagat, S. K., Tiyasha, Welde, W., Tesfaye, O., Tung, T. M., Al-Ansari, N., Salih, S. Q., & Yaseen, Z. M. (2019). Evaluating Physical and Fiscal Water Leakage in Water Distribution System. *Water*, 11(10), 2091. <https://doi.org/10.3390/w11102091>.
- Bhattacharjee, P. K. (2010). Global warming impact on the earth. *International Journal of Environmental Science and Development*, 1(3), 219.
- Fojtik, R. (2011). Extreme Programming in the development of specific software. *Procedia Computer Science*, 3, 1464–1468. <https://doi.org/10.1016/j.procs.2011.01.032>.
- Hattaraki, S., & Yaragal, A. (2021). Water Leakage and Theft Detection Using IoT. *International Journal of Scientific Research in Science*, 9(4), 26-29.
- JayaLakshmi, M., & Gomathi, V. (2015). An enhanced underground pipeline water leakage monitoring and detection system using a wireless sensor network. *International Conference on Soft-Computing and Networks Security*, 1–6.
- Jayapal, C. (2018). Water Leakage Management using Digital Twin. *Journal of Huazhong University of Science and Technology*, 50(5), 1-10.
- John, J. A., & Nivash, S. (2016). Monitoring and Controlling the Water Leakage using a Robotic Arm. *International Journal of Engineering Research*, 5(03), 764-767.
- Nidhra, S. (2012). Black Box and White Box Testing Techniques: A Literature Review. *International Journal of Embedded Systems and Applications*, 2(2), 29–50.
- Palpandian, P., Govindaraj, V., Dharmashastha, S., Gokul, S., & Mari-Selvam, K. (2021). Water Pipeline Leakage Detection and Control Management System Using IoT. *Annals of the Romanian Society for Cell Biology*, 25(4), 5752–5757.
- Rahmat, R. F., Satria, I. S., Siregar, B., & Budiarto, R. (2017). Water pipeline monitoring and leak detection using a flow liquid meter sensor. *IOP Conference Series: Materials Science and Engineering*, 190(1), 012036.

- Sithole, B., Rimer, S., Ouahada, K., Mikeka, C., & Pinifolo, J. (2016). Smart water leakage detection and metering device. *IST-Africa Week Conference*, 1–9.
- Sohraby, K., Minoli, D., & Znati, T. F. (2007). *Wireless Sensor Networks: Technology, Protocols, and Applications*. New York: Wiley-Interscience.
- United Nations, Department of Economic and Social Affairs, & Population Division. (2019). *World Population Prospects Highlights, 2019 Revision Highlights, 2019 Revision*.
- Urama, K., & Ozor, N. (2010). Impacts of climate change on water resources in Africa: The role of adaptation. *African Technology Policy Studies Network*, 29.
- Yıldırım, M. (2015). The Importance of Technological Resources in the Educational System in Design. *Procedia - Social and Behavioral Sciences*, 182, 502–506.
- Zhang, X., Tian, Q., & Liu, Y. (2020). Development of water leakage detection and localization system. *IOP Conference Series: Materials Science and Engineering*, 744(1), 012041.

## APPENDICES

### Appendix 1: Questionnaire for System Validation

#### Introduction

The main goal of the survey is to get feedback from the user based on the efficiency, usability and general performance of the developed real-time water leakage detection, monitoring and controlling system.

The respondent was

- (a) The administrator of the system
- (b) Civil engineers and water Technicians.

Kindly tick the box corresponding to your perception of the developed system.

**Table 1 System Acceptance Testing Survey Questionnaire**

S/N	Acceptance Variable	Strongly Disagree	Disagree	Neutral	Agree	Strongly agree
1.	The system would make it easier for the admin to access and monitor real-time water leakages.					
2.	The frameworks are compatible with many web devices and browsers without any issues.					
3.	The interface of the Thing Board is simple to use and interact with.					
4.	The system's overall performance has met my expectations.					
5.	The developed system is integrated with another system, e.g., a billing system.					
6.	I'll advocate for others to use this system.					

## **Appendix 2: Development of an Industrial GSM-Based Water Leakage Detection, Monitoring and Controlling System**

Dear Respondent,

I am a student pursuing a master of science in embedded and mobile systems at Nelson Mandela African Institution of Science and Technology. I am currently doing my research on water leakages.

I am carrying out research with a goal of developing an industrial GSM based water leakage detection, monitoring and controlling systems. This system will be able to detect the water leakages and close the main valve to prevent the water loss and will be able to send an SMS to the authority for the necessary action to be taken. This research is based on the Eldoret water and sanitation company (ELDOWAS). Therefore, I am requesting you to provide the necessary information to allow me to complete this project successfully.

Kindly answer the following questionnaire correctly and truthfully. Your responses, comments and feedback shall be used for the purpose of this research and not for any other course whatsoever. This study will not collect any personal information, so please do not reveal any of your personal information.

Thank you for your participation and contribution to this research.

---

**\* Required**

1. Gender \*

*Mark only one oval.*

Female

Male

Prefer not to say

---

2. Position in Company

3. Assigned station

---

4. How long have you worked in ELDOWAS?

*Mark only one oval.*

- 1-3 years
- 4-6 years
- 7-10 years
- Over 10 years

5. Do you consider water leakages as major problem in ELDOWAS?

*Mark only one oval.*

- YES
- NO

6. How do you detect, monitor and control water leakages currently in ELDOWAS?"

---

7. What are the challenges of your current system of leakage detection?

---

8. If YES. How do you rate the system in terms of the following.

---

---

---

---

---

9.This research proposed industrial GSM based water leakage detection, monitoring and control system. Which of the following features would you like to be integrated in the proposed system.

*Check all that apply.*

- SMS notification
- Email notification
- Real-time notification
- GPS notification

Cloud visualization

10.In your opinion, do you think ELDOWAS needs an industrial GSM based water leakage detection, monitoring and control system?

*Mark only one oval.*

- YES
- NO

11.If you answer is YES, what other features of the proposed automatic water leakage detection system would you recommend?

---

12. Why haven't you installed automatic water leakage detection systems in your Company?

---

---

---

---

---

---

---

This content is neither created nor endorsed by Google.

**Google** Forms

### **Appendix 3: Interview Guide**

Title of Research: Industrial GSM-Based Water Leakage Detection, Monitoring, and Controlling System.

#### **Section A: Opening Questions**

1. Would you mind if we can conduct this interview in your office, or do you have an idea of another place that is more comfortable?
2. Can I know a little about you? What is the name of your department?
3. How long have you been working in this company?
4. Do you have any questions for me before we continue with our interview?

#### **Section B: Introductory Questions**

4. How is your experience of working in this department??
5. What are the procedures for handling water leakages in the company?
6. How does the existing system work in terms of water leakages?

#### **Section C: Key Questions**

7. Which types of sensors do you use, and how do they operate?
8. How do you receive information about water leakages?
9. Do you receive information about the water leakages?

#### **Section D: Concluding Questions**

10. Which features do you have in the existing water leakage system?
11. What would be the benefits of using an Industrial GSM-Based Water Leakage Detection, Monitoring, and Controlling System in your company?

## Appendix 4: Internship Letter



Date: 31<sup>st</sup> May, 2022

Your Ref \_\_\_\_\_

Our Ref ELDOWAS/ADM/IA/VOL. VI

Office of the Deputy Chancellor, Academic, Research & Innovation,  
The Nelson Mandela Africa Institution of Science & Technology,  
P.O Box 447,  
**ARUSHA**

Dear Madam,

**RE: COLLECTION OF RESEARCH DATA- MR. DICKSON TUWEI KIPKETER**

Reference is made to your letter dated 20<sup>th</sup> May, 2022

This is to confirm that the above named student has been granted permission to undertake a research on the Topic: "**Industrial based GSM water leakage detection, monitoring and controlling system**" from 2<sup>nd</sup> June, 2022 to 31<sup>st</sup> August, 2022.

After successful completion of the research, the student is kindly requested to forward a copy of the findings to this Company for necessary action.

Please note that the student shall not be allowed to undertake any other activity other than the above mentioned.

Yours faithfully  
ELDOROT WATER AND SANITATION CO. LTD  
(ELDOWAS)  
  
J. Kiptum  
HUMAN RESOURCE & ADMIN. OFFICER  

**ISO 9001:2015 CERTIFIED**

Eldoret Water and Sanitation Company Limited  
P.O. Box 8418; Phone 053-2035000/2035202; [info@eldowas.or.ke](mailto:info@eldowas.or.ke)  
VISION: A Kenya's Most Customer-Centric Company  
MISSION: ELDOWAS is committed to Provide Adequate Quality Water and Sanitation Services Efficiently for all Through Energized, Passionate Staff, and Working Together with Commitment to Innovation  
CORE VALUES: Customer Focus, Team Players, Trusted, Professional, Inspiring, Innovativeness.

## Appendix 5: Arduino UNO Program Code for Real-Time Water Leakage Detection, Monitoring and Controlling System

```
#include <WiFi.h>

#include <ThingsBoard.h>

#define COUNT_OF(x) ((sizeof(x)/sizeof(0[x])) / ((size_t)(!(sizeof(x) % sizeof(0[x])))))

#define WIFI_AP_NAME "Redmi"

#define WIFI_PASSWORD "ac21301963"

//device 1

//#define TOKEN          "NCXQvqzuedXHSLIzXFXy" //tap

//device 2

#define TOKEN          "3fAxsLrPkv6YfTDfuxqe" //source

#define THINGSBOARD_SERVER "demo.thingsboard.io"

// Baud rate for serial debug

#define SERIAL_DEBUG_BAUD 115200

// Initialize the Ethernet client object

WiFiClient espClient;

// Initialize ThingsBoard instance

ThingsBoard tb(espClient);

// the Wifi radio's status

int status = WL_IDLE_STATUS;

#define SENSOR 27

int valve = 14;

bool valveStatus = false;

bool previousState = false;

long currentMillis = 0;
```

```

long previousMillis = 0;

int interval = 1000;

boolean ledState = LOW;

float calibrationFactor = 4.5;

volatile byte pulseCount;

byte pulse1Sec = 0;

float flowRate;

unsigned int flowMilliLitres;

unsigned long totalMilliLitres;

void IRAM_ATTR pulseCounter()

{

    pulseCount++;

}

int LED=15;

void setup()

{

    Serial.begin(SERIAL_DEBUG_BAUD);

    WiFi.begin(WIFI_AP_NAME, WIFI_PASSWORD);

    InitWiFi();

    pinMode(LED, OUTPUT);

    pinMode(SENSOR, INPUT_PULLUP);

    pinMode(valve, OUTPUT);

    digitalWrite(valve, LOW);

    pulseCount = 0;

    flowRate = 0.0;

```

```

flowMilliLitres = 0;

totalMilliLitres = 0;

previousMillis = 0;

attachInterrupt(digitalPinToInterrupt(SENSOR), pulseCounter, FALLING);
}

RPC_Response processTemperatureChange(const RPC_Data &data)
{
  Serial.println("Received the set temperature RPC method");

  // Process data

  float example_temperature = data["temp"];

  Serial.print("Example temperature: ");

  Serial.println(example_temperature);

  // Just an response example

  return RPC_Response("example_response", 42);
}

// Processes function for RPC call "example_set_switch"

// RPC_Data is a JSON variant, that can be queried using operator[]

// See https://arduinojson.org/v5/api/jsonvariant/subscript/ for more details

RPC_Response processSwitchChange(const RPC_Data &data)
{
  Serial.println("Received the set switch method");

  // Process data

  char params[10];

  serializeJson(data, params);

  Serial.println(params);
}

```

```

String _params = params;

if (_params == "true") {

    Serial.println("True");

    valveStatus = true;

    //digitalWrite(pump, HIGH);

    return RPC_Response("set_switch", "true");

}

else if (_params == "false") {

    Serial.println("False");

    valveStatus = false;

    // digitalWrite(pump, LOW);

    return RPC_Response("set_switch", "false");

}

}

const size_t callbacks_size = 2;

RPC_Callback callbacks[callbacks_size] = {

    { "set_",  processChange },

    { "set_switch",  processSwitchChange }

};

bool subscribed = false;

void loop()

{

    //init wifi

    delay(1000);

    if (WiFi.status() != WL_CONNECTED) {

```

```

reconnect();

return;
}

// Reconnect to ThingsBoard, if needed
if (!tb.connected()) {

    subscribed = false;

    // Connect to the ThingsBoard
    Serial.print("Connecting to: ");

    Serial.print(THINGSBOARD_SERVER);

    Serial.print(" with token ");

    Serial.println(TOKEN);

    if (!tb.connect(THINGSBOARD_SERVER, TOKEN)) {

        Serial.println("Failed to connect");

        return;

    }

}

if (!subscribed) {

    Serial.println("Subscribing for RPC...");

    // Perform a subscription. All consequent data processing will happen in
    // processChange() and processSwitchChange() functions,
    // as denoted by callbacks[] array.

    if (!tb.RPC_Subscribe(callbacks, callbacks_size)) {

        Serial.println("Failed to subscribe for RPC");

        return;

    }

}

```

```

Serial.println("Subscribe done");

subscribed = true;

}

Serial.println("Sending data...");

//init sensor

currentMillis = millis();

if (currentMillis - previousMillis > interval) {

    pulse1Sec = pulseCount;

    pulseCount = 0;

    // Because this loop may not complete in exactly 1 second intervals we calculate
    // the number of milliseconds that have passed since the last execution and use
    // that to scale the output. We also apply the calibrationFactor to scale the output
    // based on the number of pulses per second per units of measure (litres/minute in
    // this case) coming from the sensor.

    flowRate = ((1000.0 / (millis() - previousMillis)) * pulse1Sec) / calibrationFactor;

    previousMillis = millis();

    // Divide the flow rate in litres/minute by 60 to determine how many litres have
    // passed through the sensor in this 1 second interval, then multiply by 1000 to
    // convert to millilitres.

    flowMilliLitres = (flowRate / 60) * 1000;

    // Add the millilitres passed in this second to the cumulative total

    totalMilliLitres += flowMilliLitres;

    // Print the flow rate for this second in litres / minute

    Serial.print("Flow rate: ");

    Serial.print(int(flowRate)); // Print the integer part of the variable

```

```

Serial.print("L/min");

Serial.print("\t");    // Print tab space

// Print the cumulative total of litres flowed since starting

Serial.print("Output Liquid Quantity: ");

Serial.print(totalMilliLitres);

Serial.print("mL / ");

Serial.print(totalMilliLitres / 1000);

Serial.println("L");

tb.sendTelemetryInt("flowRate", int(flowRate));

tb.sendTelemetryFloat("totalMilliLitres", (totalMilliLitres/1000));

if (previousState != valveStatus) {

digitalWrite(valve, valveStatus);

digitalWrite(LED, valveStatus);

previousState = valveStatus;

tb.sendAttributeBool("valveStatus", valveStatus);

delay(4000);

}

}

tb.loop();

}

void InitWiFi()

{

Serial.println("Connecting to AP ...");

// attempt to connect to WiFi network

WiFi.begin(WIFI_AP_NAME, WIFI_PASSWORD);

```

```
while (WiFi.status() != WL_CONNECTED) {  
    delay(500);  
    Serial.print(".");  
}  
Serial.println("Connected to AP");  
}  
  
void reconnect() {  
    // Loop until we're reconnected  
    status = WiFi.status();  
    if ( status != WL_CONNECTED) {  
        WiFi.begin(WIFI_AP_NAME, WIFI_PASSWORD);  
        while (WiFi.status() != WL_CONNECTED) {  
            delay(500);  
            Serial.print(".");  
        }  
        Serial.println("Connected to AP");  
    }  
}
```

## RESEARCH OUTPUTS

### (i) Research Paper

Kipketer, D., Mduma, N., & Tarus, J. (2024). Industrial-Based GSM Water Leakage Detection, Monitoring and Controlling System: A Case of North Rift Valley Water Agency in Kenya. *Transdisciplinary Journal of Engineering & Science*, 15, 39-67.

### (ii) Poster Presentation

## Appendix 6: Poster Presentation



### Project Title: Industrial Based-GSM Water Leakage Detection, Monitoring and Controlling System: A Case of North Rift Valley Water Agency in Kenya

1. Dickson Tuwei Kipketer, 2. Neema Mduma, 3. John K. Tarus

Nelson Mandela African Institution of Science and Technology, P.o Box 447, Arusha, Tanzania.

#### Introduction

Water is one of the most vital elements on the planet and plays an important role in our daily activities. It is a critical resource of the planet and serves many functions for human life. Therefore, there is a need to develop measures and methods to ensure that this precious resource continues to sustain the human race's survival.

#### Problem definition

Eldoret Water and Sanitation Company (ELDOWAS) is facing the lack of an automated and affordable system that detects, monitors, and controls the water leakages from the source to the consumers.

#### Objective

To develop an industrial-based GSM water leakage, detection, monitoring and controlling system.

#### Material and Methods

The first microcontroller in the diagram is located at the source of the pipe and is connected to an inflow water sensor to measure the amount of water, it is also connected to a solenoid valve to control the flow of the water, and the buzzer is used to make an alarm or alert the authority that water leakages have occurred. At the other end of the pipe is another microcontroller connected to an outflow sensor, a solenoid valve, and a buzzer, and both devices are linked and communicate with one another via the server. The mode of transmission and data communication is WIFI/GSM and the Message Query Telemetry Transfer protocol (MQTT).

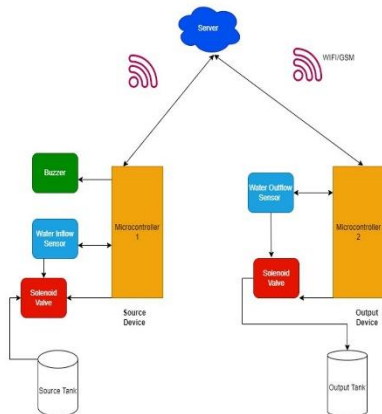

#### Results

The monitoring dashboard which shows the total amount of water visible in both the water source and the water tap at the same time. The illustration depicts the general monitoring dashboard, on which the water flowrate and total amount of water flowing through the pipe were visualized in Things Board. Water leaks were monitored in real time, and the administrator could log into the system to control and monitor the leaks remotely and automatically as they occurred. Amount of water and the flow rate at each node, which represents the source and water taps. When water leakage occurs, the two remote switches on the right-hand side of the Things Board dashboard control the water flow by switching off and on the valve at each node.

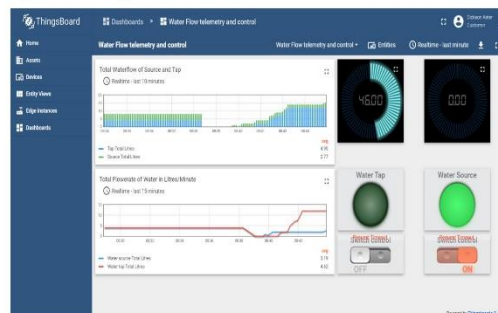

#### Conclusion

The information was remotely monitored by the engineer to view the flow rate of water via the Things Board, an IoT platform used to visualize real-time data generated by various devices connected. Furthermore, within the company premises, the system was able to detect water leaks in real-time, which benefited the company because the issue of the non-revenue collection was reduced, and the company was able to monitor the flow of water from the source, which was the reservoir, to the distribution networks. This indicates that the system met the project goals of detecting and controlling water leaks in real-time.

#### Reference

- JayaLakshmi, M., & Gomathi, V. (2015). An enhanced underground pipeline water leakage monitoring and detection system using wireless sensor network. *2015 International Conference on Soft-Computing and Networks Security (ICSNS)*, 1–6.
- Palpandian, P., Govindaraj, V., Dharmashastha, S., Gokul, S., & Mari Selvam, K. (2021). Water Pipeline Leakage Detection and Control Management System Using Iot. *Annals of the Romanian Society for Cell Biology*, 5752–5757.