

**SEMI-TRANSPARENT BUILDING INTEGRATED PHOTOVOLTAIC
PANEL: PERFORMANCE EVALUATION IN ARUSHA TROPICS,
TANZANIA**

Benedicto Mugongo Joseph

**A Dissertation Submitted in Partial Fulfillment of the Requirements for the Degree of
Master's in Sustainable Energy Science and Engineering of the Nelson Mandela African
Institution of Science and Technology**

Arusha, Tanzania

February, 2020

ABSTRACT

The performance of Building Integrated Photovoltaic (BIPV) semi-transparent windows on facades for office building has been investigated in Tanzania's tropical climate. Integrating semi-transparent BIPV with windows permits multifunctional performance improvements as energy generation and allowing light natural to enter the building, hence total energy efficiency enhancement. The aim of this study was to investigate the performance of the semi-transparent BIPV on office buildings applications. An experiment was set up at the Innovation Technological and Energy Center (iTEC), Nelson Mandela African Institution of Science and Technology (NM-AIST), Arusha, Tanzania. Measurement of weather parameters, which are solar irradiance, outdoor air temperature, relative humidity and wind speed, was taken based on various conditions, cloudy, normal and clear sky days on the assessment of the performance of the system. The experimental set-up consisted of building integrated silicon mono crystalline semi-transparent PV rated at 50 W. The electrical and optical properties were evaluated for the performance of the window glazing system. The experimental I-V and P-V curves were measured at different irradiances. Throughout the experiment, the observed module temperature was between 20 °C - 51 °C and air temperature 17 °C - 33 °C while humidity was recorded at a range 23% - 63%. Module electrical efficiency was observed to vary from 4% to 9% while the visible light transmission from 11% to 19%. It was concluded that at high temperature regardless of irradiance increase, there were observed output power and efficiency drops caused by high heat losses.

Keywords: Solar energy, BIPV, semitransparent PV, energy efficiency, daylight harvesting.

DECLARATION

I, **Benedicto Mugongo Joseph** do hereby declare to the Senate of The Nelson Mandela African Institution of Science and Technology that this dissertation is my own original work and that it has neither been submitted nor being concurrently submitted for degree award in any other institution.

Name and signature of a candidate

Date

The above declaration is confirmed

Name and signature of supervisor 1

Date

Name and signature of supervisor 2

Date

Name and signature of supervisor 3

Date

COPYRIGHT

This dissertation is copyright material protected under the Berne Convention, the Copyright Act of 1999 and other international and national enactments, in that behalf, on intellectual property. It must not be reproduced by any means, in full or in part, except for short extracts in fair dealing; for researcher private study, critical scholarly review or discourse with an acknowledgement, without a written permission of the Deputy Vice Chancellor for Academic, Research and Innovation, on behalf of both the author and the Nelson Mandela African Institution of Science and Technology.

CERTIFICATION

The undersigned certifies that they have read and here by recommend for acceptance by The Nelson Mandela African Institution of Science and Technology a dissertation entitled **Semi-transparent Building Integrated Photovoltaic Panel: Performance Evaluation in Arusha tropics, Tanzania** in fulfillment of the requirement for the degree of Masters of Science in Sustainable Energy Science and Engineering (SESE) of The Nelson Mandela African Institution of Science and Technology.

Principal supervisor

Prof. Tatiana Pogrebnaya

Signature: Date:

Co-supervisor 1

Dr. Baraka Kichonge

Signature: Date:

Co-supervisor 2

Dr. Rhee Herb

Signature: Date:

ACKNOWLEDGEMENT

I desire to precise my sincere appreciation to Prof. Tatiana Pogrebnaya, Dr. Baraka Kichonge and Dr. Rhee Herb for their great, constructive, advice, assistance, patience, immense knowledge and the highest level of commitment that they have shown to the completion of this dissertation. They dedicated their time to help me all the time of my study friendly by assisting, guiding and encouraging me until I accomplished this work. Without their close supervision this work would have been impossible. Also, I extend my thanks to NM-AIST academic staffs especially in the department of Materials, Energy Science and Engineering and NM-AIST, and students for their supports which were really encouraging and full of knowledge. We also appreciate the role played by Dr. Rhee Herb (Managing Director of Innovative Technological and Energy Center, iTEC) for his inputs and conducive environment given for the research work at the iTEC building.

Also, I acknowledge gratefully for financial support the Water Infrastructure and Sustainable Energy Futures (WISE-Futures), African Centre of Nelson Mandela African Institution of Science and Technology (NM-AIST) for enhancing and stimulating learning and research environment, which contributed greatly in completing my research work.

Since it is very difficult to acknowledge all who offered me assistance in one way or another during the preparation of this research work especially MEWES graduate seminar participants for the initiatives and modifications on the progress of the study, I would like to give thanks to all who gave me any information and assistance concerning this research study.

DEDICATION

This dissertation is dedicated to my family members for support, prayers, and encouragement towards all my educational endeavors.

TABLE OF CONTENTS

ABSTRACT	i
DECLARATION	ii
COPYRIGHT	iii
CERTIFICATION.....	iv
ACKNOWLEDGEMENT	v
DEDICATION	vi
TABLE OF CONTENTS	vii
LIST OF TABLES	x
LIST OF FIGURES.....	xi
LIST OF ABBREVIATIONS AND SYMBOLS	xiii
CHAPTER ONE	1
INTRODUCTION.....	1
1.1 Background of the problem	1
1.2 Statement of the problem.....	4
1.3 Rationale of the study	4
1.4 Objectives	4
1.4.1 General objective	4
1.4.2 Specific objectives	5
1.5 Research questions	5
1.6 Significance of the study	5

1.7 Delineation of the study	5
CHAPTER TWO.....	6
LITERATURE REVIEW.....	6
2.1 Photovoltaic potential in Tanzania	6
2.2 Types of photovoltaic system installation	6
2.3 Photovoltaic cells categories	8
2.4 Comparison of building-integrated and building-added photovoltaics	11
2.5 Types of buiding-integrated photoviltac module products.....	13
2.6 Semi-transparent building-integrated photovoltaic and general energy performance.....	16
2.7 Challenges and factors affecting the performance of semi-transparent building-integrated photovoltaic.....	20
CHAPTER THREE.....	22
RESEARCH METHODOLOGY	22
3.1 Research frame work	22
3.2 Experimental set up	22
3.2.1 Layout of the experimental and installation.....	22
3.2.2 Selection of building-integrated photovoltaic modules	23
3.3 Experimental measurement and arrangements	25
3.3.1 Measurement equipment and instruments	25
3.3.2 Designing data acquisition system circuit.....	25
3.3.3 Arrangements and measurement of temperatures and humidity.....	26
3.3.4 Arrangement and measurement of solar irradiance and wind speed during a day	27

3.3.5 Arrangements of the measuring of daylight.....	27
3.3.6 Arrangement and measurement of electrical performances.....	28
3.3.7 Arrangement and measurement of optical performances	29
CHAPTER FOUR.....	31
RESULTS AND DISCUSSION	31
4.1 Weather parameters results.....	31
4.2 Electrical performance.....	35
4.3 Optical performance	37
CHAPTER FIVE.....	41
CONCLUSION AND RECOMMENDATIONS.....	41
5.1 Conclusion.....	41
5.2 Recommendations	42
REFERENCES.....	43
RESEARCH OUTPUT	53
1. Research article	53
2. Poster presentation	61

LIST OF TABLES

Table 1: Efficiency values of different PV modules.....	9
Table 2: Market names according to the BIPV products.....	15
Table 3: Electrical, optical and thermal properties of semi-transparent BIPVs: Case studies from different locations.....	18
Table 4: Descriptions of the PV glazing considered.....	24
Table 5: Descriptions of measurement equipment for the study	25
Table 6: Results electrical measurements investigating effects of irradiance and temperature ...	36
Table 7: An example of daily measured optical parameters.....	38
Table 8: Monthly VLT measurement results of semi-transparent BIPV module.....	40

LIST OF FIGURES

Figure 1: World energy consumption for 1970 – 2040.....	2
Figure 2: Projects installation with building-applied PV in Tanzania	7
Figure 3: BIPV installation: Framed in-roof system: Less homogenous appeal is due to the contrast of the aluminum frame and PV panels	7
Figure 4: ORPV installation: Photovoltaic system in open rack installation configuration	8
Figure 5: PV cells technologies categorization.....	8
Figure 6: Mono-crystalline silicon solar cells.....	10
Figure 7: Polycrystalline solar panels	11
Figure 8: Thin film solar cell	11
Figure 9: Market share for the four European PV countries.....	12
Figure 10: Categorization of BIPVs	13
Figure 11:(a) Facade with black micromorph and semi-transparent thin-film modules in Germany and (b) Rooftop application of opaque photovoltaic modules in the Netherlands	14
Figure 12: (a) Semi-transparent PV modules integrated into a greenhouse roof; (b) Opaque and semi-transparent PVs used as shading in the Energy Research Centre in Northland	14
Figure 13: Challenges of the semi-transparent BIPV	21
Figure 14: Conceptual framework of the proposed research approach.	22
Figure 15: Fixing of the semi-transparent PV and already installed solar panel.....	23
Figure 16: Side view of in and out of the semi-transparent PV window glazing.....	24
Figure 17: Circuit layout of the data acquisition system.	26

Figure 18: Arrangement and measurements of the temperatures and humidity.	27
Figure 19: Equivalent circuit diagram (a) and real circuit (b) for I-V and P-V plots experimental measurements.	28
Figure 20: Variation of the wind speed at different test conditions.	33
Figure 21: Variation of the solar irradiance at different test conditions.	34
Figure 22: Temperature of the panel (T_m), and air inside (T_r) and outside (T_a) of the building versus solar irradiance G during a day.	35
Figure 23: The semi-transparent solar panel performance at different irradiances: I-V curves and P-V curves.	36
Figure 24: Correlation between power generated and solar irradiance.	37
Figure 25: (a) Variation of the illuminance, transmitted inside the building (E_{tr}) and incident (E_{in}), versus irradiance and (b) Relationship between the E_{tr} and E_{in}	39

LIST OF ABBREVIATIONS AND SYMBOLS

BAPV	Building applied photovoltaic
BIPV	Building integrated photovoltaic
E_{in}	Incident daylight
E_{tr}	Transmitted daylight
FF	Fill factor
I_{SC}	Short circuit current
I_{MP}	Current at maximum power
IR	Infrared
kWh	Kilowatt-hour
MEM	Ministry of energy and minerals
ORMPV	Open rack-mounted PVs
P_{max}	Maximum power
REA	Rural energy authority
Rh	Relative humidity
R.D.	Research and development
TAREA	Tanzania renewable energy authority
TMA	Tanzania metrological agency
T_a	Air temperature
T_m	Module temperature
T_r	Room temperature
VLT	Visible light transmission
V_{OC}	Open circuit voltage
V_{mp}	Voltage at maximum power
η	Power conversion efficiency

CHAPTER ONE

INTRODUCTION

1.1 Background of the problem

Energy plays a significant part in economic and human development. Access to clean, cheap, and reliable technologies is considered as a means to achieve sustainable development goals (Agrawal & Tiwari, 2010; Kichonge, 2018). An energy deprivation in terms of quantity along with quality causes poor development thereby poverty and increased human sufferings (Nussbaumer, Bazilian & Modi, 2012). About 1.2 billion people in the world are approximated to live without access to energy, commonly from rural areas in Africa and Asia (Azadian & Radzi, 2013). This situation also affects Tanzania as only 24% of people have access to energy (NBS, 2016). The historical world dependency on fossil fuels at approximately 80% has added significantly to the climate change, and thus increases the poor communities suffering (Boden, Marland & Andres, 2009; Pavlović, Radonjić, Milosavljević & Pantić, 2012; Shukla, Rangnekar & Sudhakar, 2015). Climate change being an impending crisis is expected to intensify the challenges facing the poor. Moreover, the cost of producing electricity using fossil-based sources is expected to progressively increase owing to rapid population and economic growth thus leading to depletion of existing proven fossil fuels reserves (Kichonge, 2018). The global energy consumption increases at about 8-10% annually, and expectations will reach 40% in the year 2040 as depicted in Fig. 1. The fast-economic development in developing countries is expected to increase global energy demand by the year 2040, hence renewable energy is projected to be the fastest growing energy source providing 14% of the primary energy in the year 2040 (Peng *et al.*, 2016).

Generally, industry, transportation and buildings and building construction are the primary energy consuming sectors. When these are joined, they are accountable for approximately 36% of worldwide final energy consumption and thus contributing closely to 40% of the total carbon dioxide related emissions (Joseph, Pogrebnaya & Kichonge, 2019). Energy demand is projected to continue to increase, attributed to enhanced global economy and therefore access to energy in developing countries, increased proprietorship and use of energy-consuming appliances coupled with the quick global buildings growth in floor area, at approximately 3% per year (Biyik *et al.*, 2017).

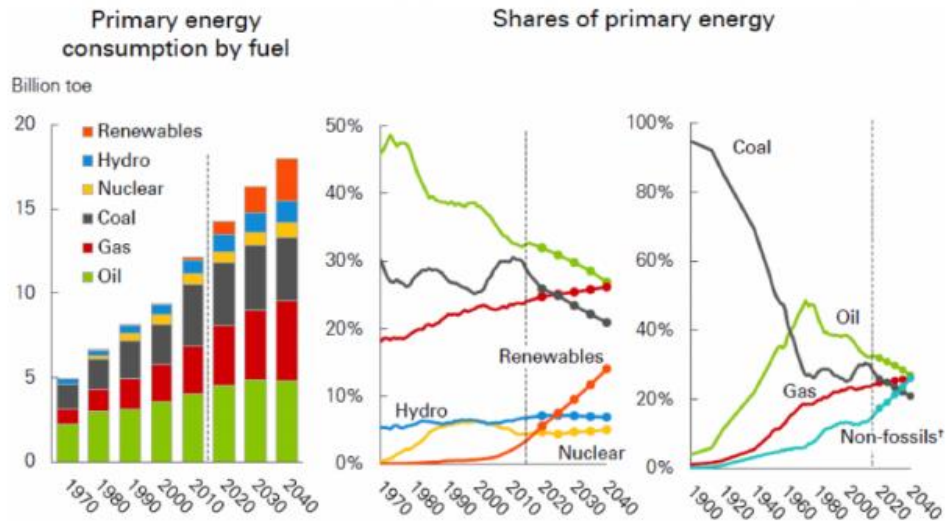

Figure 1: World energy consumption for 1970 – 2040 (Bishoge, Zhang & Mushi, 2018).

Due to projected rapid inhabitants increase and economic development in energy consumption, energy is required as alternative sources to be gradually included in the future global mix (Nepal, 2012; Radmehr, Willis & Kenechi, 2014). Varieties of solar technologies are widely recognized as clean with minimal greenhouse gas releases and thus contribute to the efforts towards climate change mitigation through a direct reduction in CO₂ emissions (Kichonge, 2018). Solar energy is radiant energy which is harvested using a range of advanced technologies such as building integrated photovoltaic (BIPV) and solar heating (Shukla, Sudhakar & Baredar, 2016). The BIPV are basically photovoltaic systems forming an integral part of the building envelope. Photovoltaic is currently the fastest-growing and among elegant technologies available for harnessing energy in buildings (Debbarma, Sudhakar & Baredar, 2017a; Shukla, Sudhakar & Baredar, 2017). The technology is increasing and becoming one of the efficient approaches in harvesting renewable energy for buildings in the quest to minimize energy crisis through over-dependence on fossil fuels and other un-clean energies (Ban-Weiss *et al.*, 2013; Shukla, Sudhakar, Baredar & Mamat, 2018). The conversion of solar radiation into energy is achieved through PV solar cells such as monocrystalline silicon, polycrystalline silicon, and amorphous silicon (dos Santos & R  ther, 2012; Azadian & Radzi, 2013).

With 30% to 40% of the world's total end-use energy consumption delivered for commercial and residential buildings applications, energy-efficient buildings become very attractive at reducing lighting, cooling, and heating-related energy consumption (Peron, Rat-Fischer, Lalot, Nagle & Bovet, 2011; Chae, Kim, Park & Shin, 2014). The use of BIPV to replace the

conventional materials in the building offers a combination of properties which not only preserve energy but also generate electricity through the efficient conversion of solar radiation (Agathokleous, Kalogirou & Karellas, 2018). The BIPV technology addresses the goals that intend to achieve ‘building net-zero energy’ consumption through transformations of building from energy consumer to sustainable energy producer (Kim, Kim & Kim, 2015; Sorgato, Schneider & Rüter, 2018). A sustainable building is capable to minimize energy consumption, while at the similar period supply its own energy demand through self-generation (Joseph, Pogrebnaya & Kichonge, 2019).

Applications of BIPV technology enables the photovoltaic modules to serve several purposes such as roof, facade, thermal insulators, and noise protection and as weather protectors (Sorgato, Schneider & Rüter, 2018). The BIPV technology development and the corresponding utilization in building construction provide aesthetical, economic and technical solutions in solving environmental challenges, and daylight harvesting for the provision of the natural light during the day (Peng *et al.*, 2016). The BIPV is rapidly emerging attractive option for research and application as a result of technology developments, continual decreasing in PV materials cost, and the rise in renewable energy technologies promotions among important players (Petrichenko, Üрге-Vorsatz & Cabeza, 2019). Among BIPVs technologies, semi-transparent integrated PV is the most used in facades, windows, and greenhouses because it generates good environment by allowing natural light to enter into the building while generating energy and thus the most favorable future energy system in the urban environment. Available performance data as reported by manufacturers are normally established under laboratory conditions which are solar irradiance of 1000 W/m^2 , the temperature of $25 \text{ }^\circ\text{C}$, and air mass value of 1.5 (El Tayyan, 2011; Shukla, Sudhakar & Baredar, 2017). The information established under laboratory conditions in most cases does not represent actual conditions established at specific locations and therefore leading to significant differences output values (Bücher, 1997). Also the cost analysis and energy payback time in most cases are not considered for the BIPV basing on local conditions. However, there is still a lack of studies in tropical regions regarding multi-functional performance of semitransparent BIPV as compared with conventional PV technologies. Much of research on the multi-functional effect of semi-transparent BIPV has attempted utilization of theoretical modeling for the semi-transparent BIPV modules which might not truly reflect the ones currently available in the market (Ahmed, Hamada & Salih, 2019; Halme & Mäkinen, 2019). Tanzania being in tropical regions is normally characterized with

hot and humid climate conditions almost whole year-round resulting in its buildings being cooling-load dominated. Therefore, with this drawback, the study aims at investigating the electrical and optical performance of the semitransparent BIPV for office building applications mostly suitable for tropical conditions.

1.2 Statement of the problem

Energy consumption is still increasing daily in Tanzania. This is due to improvement of life standard, economic expansion and socio-economic growth (Bishoge, Zhang & Mushi, 2018). In this situation, renewable energy sources are required, but it also requires going for more energy efficiency. Solar energy is one of the greatest ways of harvesting renewable energy for buildings to overcome this problem. Normally, for solar installation in buildings, photovoltaic panels are integrated to a second layer part of the building's construction. Semi-transparent integrated PVs produce energy, and are used as building material, and create a pleasant environment allowing natural light to enter into the building. Different studies show that semi-transparent BIPV technologies have been commercially implemented in various countries around the world and the technology has proved to be more successful than building-added photovoltaic (Kumar, Sudhakar & Samykano, 2019). Therefore this study targets to evaluate electrical and optical characteristics of the semi-transparent BIPV panel in Arusha tropics.

1.3 Rationale of the study

The study considered only semitransparent BIPV; however there are other types of the BIPV that may give more energy performance. Therefore due to time limit only one type of BIPV was used. Also, this study was conducted for only three months the results may be different with others. Even though majority of the data was verified and corrected, some of it still may have errors in it. Also, shading devices are assumed not existed as semi-transparent provides a certain level of shading. However, if indoor shading is used in some particular circumstances, these shading devices could lead to significant impact on energy performance.

1.4 Objectives

1.4.1 General objective

The general objective of the study is to evaluate experimentally energy performance of semi-transparent BIPV in Arusha tropics, Tanzania.

1.4.2 Specific objectives

- i. To analyze the electrical performance of the semi-transparent BIPV system.
- ii. To analyze the optical characteristics of the BIPV system.

1.5 Research questions

- i. What are the electrical properties of the semi-transparent BIPV system?
- ii. What are the optical properties of the BIPV system?

1.6 Significance of the study

This study will add knowledge in broad understanding of the performance of BIPVs in the tropics that concentrates on alternative energy sources and making building and greenhouse systems as energy efficient as possible. When semi-transparent BIPV is used in buildings, they provide effective day lighting which reduces the need of artificial lighting energy consumption during the daytime and reduce the heat gain in a building by blocking the incoming solar radiation

1.7 Delineation of the study

Semi-transparent BIPV technology is becoming commonly used in most modern buildings worldwide, but not yet exploited in Tanzania. Solar PV is available but not integrated. On the other hand, office buildings are mostly suitable for BIPV semi-transparent technology because they devour energy primarily in daytime, as solar energy are converted into electricity, therefore energy storage can be avoided with the cost associated (Joseph, Pogrebnaya & Kichonge, 2019). The use of solar energy is often more effective way of improving energy outcomes in office buildings than increasing generation capacity. Therefore, there is a need to conduct a study of this semi-transparent photovoltaic technology basing on local conditions.

CHAPTER TWO

LITERATURE REVIEW

2.1 Photovoltaic potential in Tanzania

Photovoltaic technology is the one that uses cells to convert sunlight into electricity. PV cells consist of one or two layers of a semi conducting material, usually silicon. Tanzania has sunshine hours per year which range between 2800 and 3500 with solar irradiation of 4–7 kWh/m² per day (NBS, 2016). According to Tanzanian energy sector under the universal principles of the Energy Charter, the annual per capita consumption of electricity is around 133 kWh, which is still extremely low compared to the world average of 2500 kWh. The electricity connection level target was 33% by 2015, during which the expected installed capacity for power generation was guaranteed access to 3000 MW. The government set an electricity access target of 50% by 2025, 75% in 2030 and 100% by 2040 according to Ministry of Energy and Minerals (MEM) (NBS, 2016). Due to good solar resources of Tanzania, the photovoltaic can be used to minimize the energy scarce. Up to 2017, about 5.3 MW of photovoltaic solar energy have already installed in Tanzania, this shows how PV is growing in the country (TAREA, 2017). However, the photovoltaic installations have not been integrated with windows for power generation and controlling the light entering the building. This is because of the level of awareness of the application of the BIPV product and lack of expert on these solar modules.

2.2 Types of photovoltaic system installation

The photo-voltaic technologies subdivide into three types; building added PV (BAPV), building-integrated PV (BIPV or BIPVT) and open rack-mounted PV (ORMPV). The BAPV are added to the building and do not add anything to the system besides producing the electricity. The ORMPV are PV systems which are mounted on rooftops, normally with a few inches gap and parallel to the surface of the roof. And, besides, they can be ground mounted and produce energy, also be used as a canopy for shading purposes. In ORMPV systems, the main factor is to increase energy generation; hence PV panels face to the optimal azimuth and tilt angles. These systems are only intended to generate electricity. The BIPV are PVs installed in either roofs or other parts of the building such as facades, windows or balcony.

The BIPVT is a building integrated photovoltaic-thermal system, which is used for the

simultaneous conversion of the solar energy into thermal energy and electricity (Debbarma, Sudhakar & Baredar, 2017a; Kant, Pitchumani, Shukla & Sharma, 2019). The system contains a PV panel for the conversion of solar energy into energy due to the photovoltaic effect and into thermal energy through the absorption process (Agathokleous, Kalogirou & Karellas, 2018). The BIPV system applied as thermal insulation to the building envelope in hot and humid climates showed the significance of insulation on energy use in residential and commercial buildings. Figures 2-4 show different PV installations to the building on a roof and walls with BAPV, BIPV, and ORMPV.



Figure 2: Projects installation with building-applied PV in Tanzania.



Figure 3: BIPV installation: Framed in-roof system: Less homogenous appeal is due to the contrast of the aluminum frame and PV panels (Skaaland, Ricke, Wallevik & Strandberg, 2011).

The building-integrated photovoltaic means PV system is part of the building which is integrated into building design (Caamaño-Martín *et al.*, 2008). That means, PV panel is the part of construction material like tiles, facade ornaments and glass of pane and replaces these materials during design phase in order to get the highest saving in construction and energy

saving cost as well as daylight harvest. Figure 3 shows installation with semi-transparent BIPV.



Figure 4: ORPV installation: Photovoltaic system in open rack installation configuration (Kumar, Reddy & Praveen, 2017).

2.3 Photovoltaic cells categories

There are different Photovoltaic (PV) cells categories such as silicon-based, non-silicon based and nanomaterial cells as new concept devises and future technology. Also, different solar cell modules made from crystallines such as mono, poly, and ribbon will further be reviewed. Figure 5 shows the PV solar cell categorization regarding technology to summarize this section.

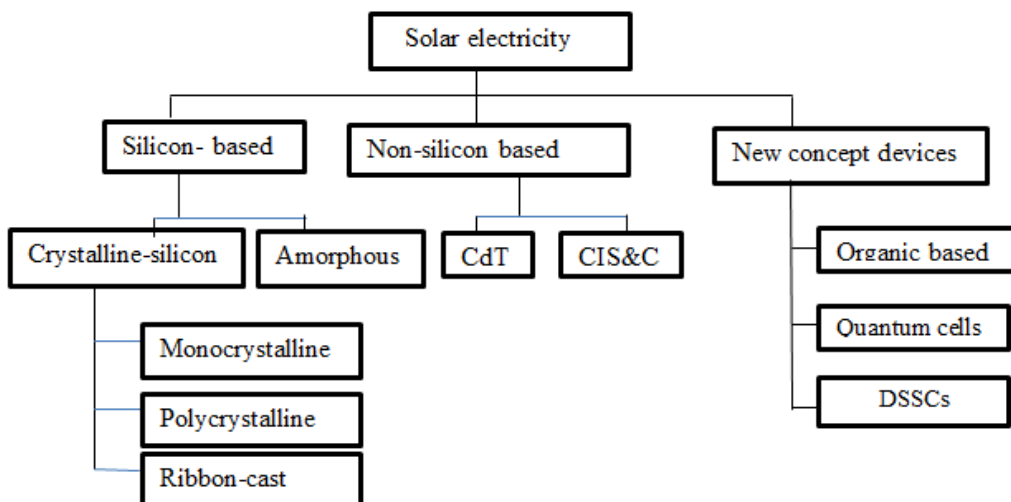

Figure 5: PV cells technologies categorization (Debbarma, Sudhakar & Baredar, 2017a).

In studies carried out by Yoo and Manz (2011) and Green *et al.* (2019), the technologies discussed were crystalline silicon wafer-based cells (c-Si) and thin films such as amorphous (a-Si), organic PV (OPV), DSSCs, and CIGS. Recently, the efficiency of the solar panels in the market is rating as high as 26% (Green *et al.*, 2018) which are monocrystalline and polycrystalline, whereas 11% –17% efficiency range is for the majority of the solar panels. Table 1 shows different PV modules with their efficiencies at Standard Test Condition (STC).

Table 1: Efficiency values of different PV modules.

Type of PV module	Module efficiency at STC (%)
Mono crystalline silicon (mo-c-Si)	15-26
Poly crystalline silicon (po-c-Si)	11-22.3
Copper indium gallium selenide (CIGS)	10-19.2
Cadmium telluride (CdTe)	9-22.1
Amorphous silicon (a-Si)	5-11.9
Heterojunction (HIT)	18-20
Dye-sensitized solar cell (DSSC)	2.9-11.9
Organic photovoltaic (OPV)	4-11.2

Green *et al.* (2019) and Biyik *et al.* (2017).

In the study by Lee and Ebong (2017), different PV cells were discussed such as crystalline silicon PV, thin film PV cells and 3rd generation technologies (OPV and DSSCs). The report showed advantages of the crystalline silicon PV as silicon is simple to fabricate and available in the market as well as cheap. The report demonstrates good opportunities for the organic PV and DSSCs as they are opaque film that is integral to semi-transparent and transparent part for the tinted glasses. These are used for architectural decoration of doors and windows for the penetration of the daylight in office and residential buildings.

Debbarma, Sudhakar and Baredar (2017a) studied monocrystalline Si PV cells which refer to modules made by integrating cells of large crystals of pure silicon ingots, and cylindrical in shape. They are formed by melting pure silicon with few percentages of impurities in a crucible at 1425 °C. During the melting process, silicon is being doped by group V (for n-type semiconductor) or group III dopant (for p-type semiconductor); for the latter, boron is the most preferred dopant (Shukla, Sudhakar, Baredar & Mamat, 2018). Most of the studies show monocrystalline solar cells have an efficiency range of 11-16% (Shukla, Sudhakar,

Baredar & Mamat, 2017). They are chemically stable and can last for a very long time if properly protected. In sub-Saharan Africa, these solar panels are not mostly used and installed because they are expensive and affected by temperature. Fig. 6 shows mono-crystalline and multi-crystalline Si solar cells which have different colors.



Figure 6: Mono-crystalline silicon solar cells (Debbarma, Sudhakar & Baredar, 2017b).

According to Ibn-Mohammed *et al.* (2017), multijunction solar cells were reported as the highest-efficiency solar cells of about 18-20%. Therefore photons are absorbed and converted that have energies greater than the band gap of lower layer and less than the band gap of the higher layer (Nasr, 2013; Green *et al.*, 2017).

Kato, Wu, Hirai, Sugimoto and Bermudez (2018) discussed the polycrystalline cells which are made by integrating cells from many of silicon wafers. They are very similar to monocrystalline modules except for the fabrication process. Different studies show their efficiency is between 9-13% (Deng *et al.*, 2016). The polycrystalline cells are fabricated from pure molten Si in a square-like tank, in order to determine the distribution of impurities and the grain size, cooling down is an essential step. Polycrystalline cells are blue in color because of the missing absorption of higher energy photons. They are mostly used in Sub-Saharan countries because are not expensive and have a long life with no degradation over time but easily affected by temperature (Shukla, Sudhakar & Baredar, 2017). Figure 7 shows the polycrystalline panels which appear to be blue in color.



Figure 7: Polycrystalline solar panels (Kato, Wu, Hirai, Sugimoto & Bermudez, 2018).

From Oulmi, Bouloufa, Benhaya and Mayouche (2019), non-crystalline PV cells properties were reported and are in the second generation. They are fabricated using the vapor-deposition process which deposits a photovoltaic substance onto a solid surface like glass or metal to create a thin layer of silicon material of about 1 μm thickness. Solid black appearances were identified to a thin film panel. This paper concludes that non-crystalline PV solar cell has an advantage as has the possibility of depositing amorphous silicon at very low temperature; they are also lower cost with a high absorption coefficient. Figure 8 shows the thin film solar cell and its structure.

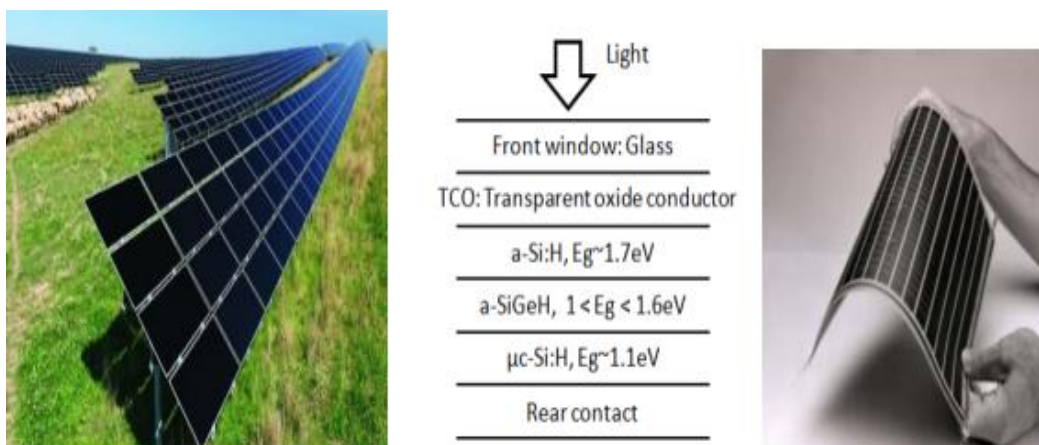

Figure 8: Thin film solar cell (Dharmadasa, 2018).

2.4 Comparison of building-integrated and building-added photovoltaics

The comparison of BIPV and BAPV can be detailed in terms of market penetration,

classification, function/power generation, heat and light harvesting. The PV system is used mainly on buildings due to its resourcefulness and nonstop growth. However, PV installed prioritizes only energy generation while ignoring aesthetic considerations (Heinstein, Ballif & Perret-Aebi, 2013; Kumar, Sudhakar & Samykano, 2019). According to Zomer, Costa, Nobre and R  ther (2013) BIPV and BAPV were differentiated, the key difference is that BIPV has three functions which are electrical energy generation, light harvest to be used during a day and replacing the conventional elements of construction (Hadavinia & Singh, 2019) . The current BAPV systems in buildings normally focus only in power generation maximization with nothing added while the energy generated is regarded as a design parameter (dos Santos & R  ther, 2012; Zomer, Costa, Nobre & R  ther, 2013).

According to Kumar, Sudhakar and Samykano (2019) and Biyik *et al.* (2017), the BAPV and BIPV are estimated in terms of volume and cost. There is limitation of the market volume for BIPV compared to that of BAPV due to the small percentage of the residential houses undergoes renovation of the roof. Only renovation essential for the limited replacement with PV panels looks to be more economical and attractive. For any roof which sun shines, BAPV are commonly used. For example, about 5.3 MW of photovoltaic solar energy has already installed in Tanzania (NBS, 2016). Figure 9 shows the market share for the four European PV markets of the BIPVs, ground mounted and BAPV.

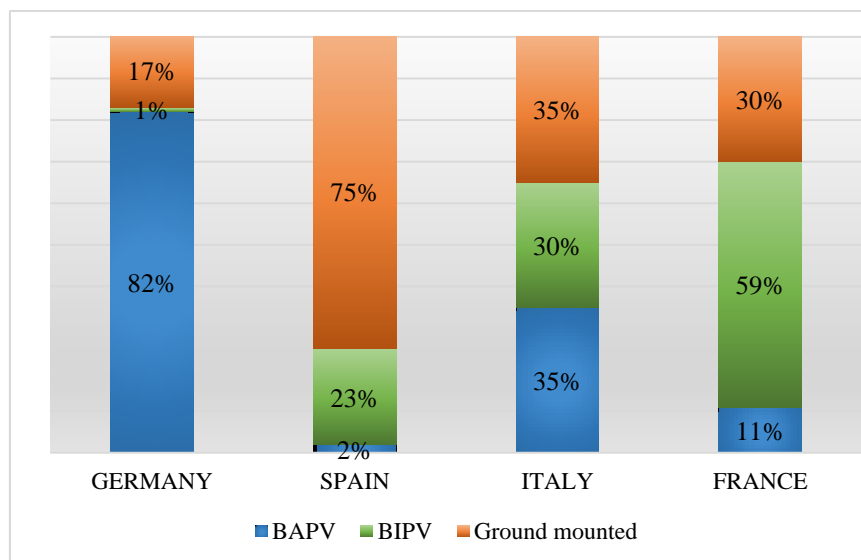

Figure 9: Market share for the four European PV countries (Heinstein, Ballif & Perret-Aebi, 2013).

In Fig. 9, the market growth is shown for the BIPV, BAPV, and ORPV for the four European

countries of Germany, Spain, Italy, and France. In Germany, about 82% were installed with BAPV followed by 17% of ground mounted and only 1% was integrated into the building. Ground-mounted installations in Spain have been very popular with 75% followed by 23% of BAPVs and only 2% accounts for BIPV. In Italy, the market share for the BAPV and ORPV are 35% followed by 30% of the BIPV, it means the level of awareness on both systems is greater. In France, there is a greater increase of the BIPV as 59% increases followed by 30% of ORPV and 11% of BAPV. We might suggest that the higher growth of BIPVs installation in France is due to self-sufficiency, energy efficiency, and thermal insulation and level of awareness among stakeholders.

2.5 Types of buiding-integrated photoviltac module products

The ranges of BIPV module technology are very wide, and are classified in different ways as shown in Fig. 10.

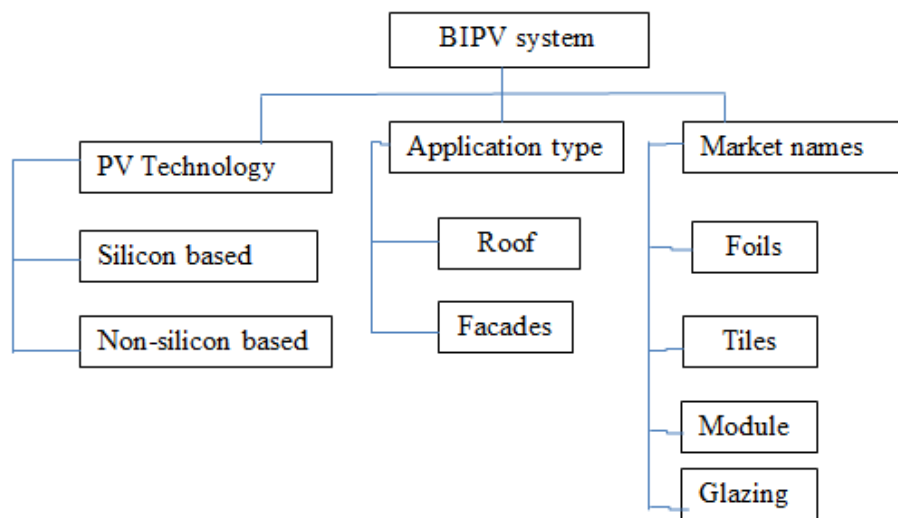

Figure 10: Categorization of BIPVs (Baljit, Chan & Sopian, 2016; Biyik *et al.*, 2017).

As described in Zogou and Stapountzis (2012) and Biyik *et al.* (2017), BIPV are categorized based on silicon-based PV and non-silicon based PV. The silicon-based are monocrystalline, polycrystalline, amorphous and ribbon cast polycrystalline while the non-silicon-based PV cells are composed of copper indium gallium selenide (CIGS), copper indium selenide (CIS) and cadmium telluride (CdTe).

On the other hand (Joseph, Pogrebnaya & Kichonge, 2019), BIPVs are categorized based on their application as a roof system and facades and can be semi-transparent, transparent or

opaque. Roofing PV is an integrated part of the building that replaces conventional materials. Transparent BIPV can be also part of energy efficient glazing, where they are used instead of usual glass and also in storage houses for the provision of natural lighting during the day, while opaque is used as a roof for energy generation (Basnet, 2012). Facades are part of the fabric or as additional walls, and installation is affected by the geographical position of the site namely weather parameters (solar irradiation and temperature), and also tilt angle. Facades can be installed in windows or walls and greenhouses. Figures 11 and 12 show BIPV applications as roof and facades.





Figure 11: (a) Facade with black micromorph and semi-transparent thin-film modules in Germany and (b) Rooftop application of opaque photovoltaic modules in the Netherlands (Kha, 2013).



Figure 12: (a) Semi-transparent PV modules integrated into a greenhouse roof; (b) Opaque and semi-transparent PVs used as shading in the Energy Research Centre in Northland (Basnet, 2012).

The market names according to BIPV product are shown in Table 2. According to Jelle, Breivik and Røkenes (2012), the BIPVs are categorized based on their market names as foil products, tiles products, solar glazing products, and module products. In module products, they are used with several types of roofing material and are similar to the conventional PV materials. The solar glazing products are normally integrated into the facade, roof or in windows products, and provide various aesthetic solutions. The foil products are lightweight and flexible, and it is simple in installation. The tile products can cover the entire roof or just parts of the roof. They are generally arranged in modules with the appearance and properties of standard roof tiles and substitute a certain number of tiles (Mei *et al.*, 2009).

Table 2: Market names according to the BIPV products.

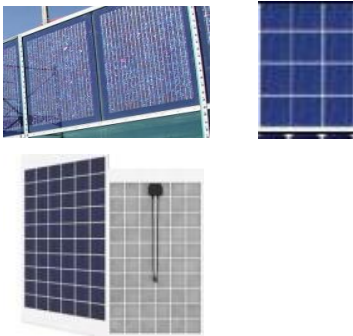
Type of Product	Description	Examples
Foil	They are adhesively mounted, no frame required, and low mounting cost. They are good for large roof expanses. The big advantage of these is that they are flexible to any shape as you need.	
Tiles	These are mostly PV product, installed to the whole roof or part of the roof. They can be installed by a roofer with little training.	
Glazing product	These are used as shading devices, windows, roofs, facades, and green houses. Also, they have the ability to transmit the day light for the options of using natural lighting while producing electricity.	

Type of Product	Description	Examples
Module	These are the cheapest form of integration; have improved appearance over external frames. They are normal PV modules. Most are opaque PV used for roofing purposes.	

Jelle, Breivik and Røkenes (2012), Debbarma, Sudhakar and Baredar (2017a) and Debbarma, Sudhakar and Baredar (2017b).

2.6 Semi-transparent building-integrated photovoltaic and general energy performance

The semi-transparent BIPV facade is one of the building facades that have an effect on energy performance and share some connections with the other kinds of buildings. Few studies show the installation of the semi-transparent BIPV have been performed basing on the local condition, hence review of these taking into consideration on specific location is very important (Saadon, Gaillard, Giroux-Julien & Ménézo, 2016). Electrical, thermal and optical performance concerns the parameters such as current and voltage, power generation, visible light transmittance, heat transfer coefficient, u-values solar heat gain coefficient or when the module is exposed to different irradiance (geographical location) and other factors such as air ventilation. Case studies from different locations are summarized in Table 3. Kha (2013) experimentally investigated the performance of semi-transparent BIPV windows in Singapore. The overall energy performance was evaluated by calculating net electrical benefits (NEB) including the generation of electricity, the reductions of cooling energy and artificial lighting energy, through parameters of thermal, electrical and optical properties. Six semi-transparent BIPV modules were tested. The results showed the NEB of the BIPVs depended on the WWR and when compared with other commonly used glazing systems, semi-transparent BIPV windows were found to be the best in terms of overall energy saving performance. In conclusion, the study demonstrated the good energy saving potential of the semitransparent BIPVs windows to be used for the natural lighting.

Kapsis and Athienitis (2015) observed the effect of optical properties by simulation on semi-transparent PV windows. The parameters evaluated were the orientation of facades, window-

to-wall ratio, and electrical lighting. It was reported that semi-transparent PV windows with 10% visible active transmittance had the best energy-saving potential. The study concluded that to maximize the energy saving potential of semi-transparent PV windows, selection of optical properties is necessary due to daylight and lighting controls applied to the building. Didoné and Wagner (2013) conducted an evaluation of the potential energy saving and energy generation of semi-transparent PV windows in two Brazilian cities of Fortaleza and Florianopolis. The result shows that energy savings were 19% to 43% for these cities of Fortaleza and Florianopolis, respectively. Also, in Fortaleza, energy of 493.6-798.6 kWh/year was achieved in PV a window which was comparable to that of 591.8-750.3 kWh/year in Florianopolis city. The study concluded that reduction of the energy consumption is possible for artificial lighting and cooling utilizing suitable control frameworks and to generate more energy using semi-transparent photovoltaic panels in windows.

Peng *et al.* (2016) developed a numerical simulation model using Energy Plus to predict the overall energy performance of photovoltaic double-skin facade (PV-DSF). The energy saving potential was compared with other technologies while sensitivity analyses of air gap depths were conducted and the optimal air gap was obtained in Berkeley. In comparison to other technologies, the natural ventilated saved electricity by PV-DSF per year was about 35%. The PV-DSF method enabled to generate 65 kWh/year per unit area, while 50% of lighting electricity to be saved in winter. The study concluded that thicknesses between 400 mm and 600 mm could be recommended as the optimal air gap range for a PV-DSF installation while 15% of the annual net electricity use could be saved and produced good thermal and daylighting if an air gap depth of 600 mm was chosen.

In work by Vats and Tiwari (2012) evaluation of the energy performance of a semi-transparent BIPVT integrated to the roof of a room was performed. Energy has been compared for six different PV modules. It was observed that maximum annual electrical energy was 810 kWh for hetero-junction PV over the crystalline silicon cell while that was 464 kWh for amorphous silicon panels. The study concluded that the heterojunction PV module is more suitable for producing electrical power compared to amorphous silicon.

According to Yang (2015) open-loop air-based BIPVT systems were experimentally investigated. The experimental approaches in this study were indoor tests in the built environment, outdoor test in specially designed test cells, and building size experiments and

demonstrations. Experimental results confirmed that the two-inlet BIPVT concept improved thermal efficiency by 5% compared to a conventional single-inlet system. Comparisons of prototypes were conducted on mono-crystalline opaque PV and semi-transparent mono-crystalline PV modules. Results showed that applying semi-transparent PV modules with 80% module area covered by solar cells in BIPVT systems increased energy efficiency by up to 7.6% compared to opaque ones.

Table 3: Electrical, optical and thermal properties of semi-transparent BIPVs: Case studies from different locations.

Location	Description	Results	Reference
Brazil	The energy saving potential of semitransparent PVs windows was investigated.	30% of the total HVAC was saved using daylight; 18%-59% of NEB was achieved. 19%-43% of energy consumption was reduced.	Chae, Kim, Park and Shin (2014)
California	Energy performance of photovoltaic double-skin facade (PV-DSF) was conducted.	50% of lighting electricity were saved in winter and 15% of the annual net electricity were saved	Peng <i>et al.</i> (2016).
Canada	Air-based building integrated photovoltaic-thermal (BIPVT) systems were investigated.	Thermal efficiency was improved by 5% compared to a conventional single-inlet system.	Yang (2015).
Canada	Potential benefits of semi-transparent photovoltaic windows were evaluated by simulation.	The STPV module with 10% visible effective transmittance resulted in the lower electricity consumption of 5 kW h/m ² /yr.	Kapsis and Athienitis (2015).
Cameroon	Building integrated	The system area of 36.45 m ²	Ekoe, Akata,

Location	Description	Results	Reference
	semitransparent photovoltaic thermal system (BISPVT) were simulated.	can annually produce an amount of thermal energy of 76.66 kWh at an overall thermal efficiency of 56%.	Njomo and Agrawal (2015).
Germany	Calculation of the thermal impact on building performance of an integrated PV facade was conducted.	12% of heating energy was saved.	Infield, Eicker, Fux, Mei and Schumacher (2006).
India	Building semitransparent PVs thermal system was integrated into the roof and facades.	Energy efficiency was 11- 18% at the roof and 13-18% at the facade. Electrical efficiency at the roof and facade were 85% and 72% respectively.	Shukla, A., Sudhakar, K. and Baredar, P. (2016).
India	Energy performance of a semi-transparent BIPVT integrated to the roof of a room was performed.	The annual electrical energy generated was 810 kWh for heterojunction while annual thermal energy was 464 kWh for amorphous silicon.	Vats and Tiwari (2012).
India	The three semitransparent BIPVs on power and optical properties were evaluated.	The values of VLT for the three PV modules were in the 7.09%–23.49% range, and power generation and efficiency increased by around 0.01–0.13%.	Liu, Young, Horng, Shiue and Lee (2016).
Japan	Evaluation of electrical and solar heat using BIPVT hybrid was done.	Thermal efficiencies for glazed and unglazed systems were 20-22% and 29- 36% respectively.	Nagano, Mochida, Shimakura, Murashita and Takeda (2003).
Japan	Semi-transparent BIPV was evaluated by simulation.	5.3% of heating and cooling were reduced. Net energy savings of 3.0–8.7% were achieved.	Wong, Shimoda, Nonaka, Inoue and Mizuno (2008).
Korea	Evaluation of electrical	In the cloudy day, energy	

Location	Description	Results	Reference
	thermal energy from different conditions was done, as sun shading module was rated at 40 kWp, and the rooftop modules were rated at 60 kWp	generated was 40.8 kWh while solar irradiation was 2513 Wh/m ² . In a normal day, energy generated was 69.8 kWh while solar irradiation was 4458 Wh/m ² . In sun day, energy generated was 68 kWh while solar irradiation was 6554 Wh/m ² .	Yoo, Lee and Lee (1998).
Spain	Energy Performance of WWR of five STPV elements was evaluated.	Energy saving potential ranges between 18% and 59% compared to the normal glass.	
Singapore	Performance of semi-transparent BIPV windows in a tropical climate was conducted.	The NEBs vary from 1.79 to 23.26 kWh/m ² /yr and increase steadily with the increase in WWR.	Kha (2013).
Turkey	The energy of the semitransparent a-Si solar cells to the Tromble wall was evaluated.	Average electrical efficiency was 4.52% and thermal energy was 27%.	Bishoge, Zhang and Mushi (2018).
USA	Semi-transparent BIPV windows were studied for the overall energy commercial building in various tropics.	The system can save 30% of the total heating and ventilation system energy compared with the clear glass system.	Chae, Kim, Park and Shin (2014).

2.7 Challenges and factors affecting the performance of semi-transparent building-integrated photovoltaic

The semitransparent BIPV are affected by different factors for its performance. According to Kha (2013) and Shukla, Sudhakar and Baredar (2016), many researchers have been focused on factors affecting the performance of the semitransparent BIPV PV cell technology, ambient conditions and selection of required equipment and shading impact. From authors (Shukla, Sudhakar & Baredar, 2017; Shukla, Sudhakar, Baredar & Mamat, 2018), studies investigated and determined that small economies of scale, long payback period and high initial capital costs of installation and limited information on market potential are the big

challenges facing BIPVs development as summarized in Fig. 13.

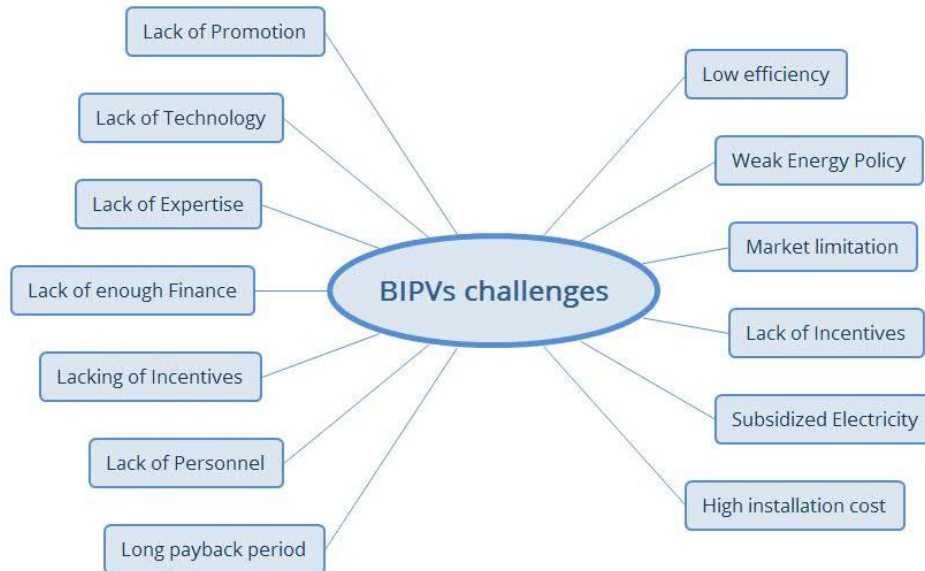

Figure 13: Challenges of the semi-transparent BIPV (Shukla, Sudhakar, Baredar & Mamat, 2018).

BIPV challenges were discussed in details by authors (Mousa, 2014; Goh, Yap, Goh, Seow & Toh, 2015; Baljit, Chan & Sopian, 2016) to include among others, technological limitations, poor financial support, high initial investments, low acceptance level to the community and level of awareness of the architect who lacks essential practical knowledge, and general public awareness lack of government policy. Furthermore, challenges like aesthetical, technical, economic and social have been determined to face PV cells operations as detailed in (Defaix, Van Sark, Worrell & de Visser, 2012; Nasr, 2013; Sai *et al.*, 2015). In aesthetical aspect, the studies discussed that to install PV module to the existing structure of the building many architectures make it very difficult in implementation by building stakeholders. Technically, the PV modules need large space for installation and it is difficult to get a good orientation. In economics, the study shows that the cost of installation and its implementation is high rather than the normal PV system. In social, people are not familiar with the new technology as a reliable source of energy, they do not know how efficiently solar energy can be used in buildings for passive light and also generating electricity. Hence awareness to stakeholders are required to be conducted in using BIPV systems.

CHAPTER THREE

RESEARCH METHODOLOGY

3.1 Research frame work

The proposed performance energy evaluation procedure of the semi-transparent BIPV is shown in Fig. 14, where the main objective is to evaluate the system energy performance. This includes experimental investigations of the semi-transparent photovoltaic modules in the window based on three local conditions of clear, cloudy and normal sky days conditions to establish their performance parameters, and overall energy performance of building with semi-transparent PV windows.

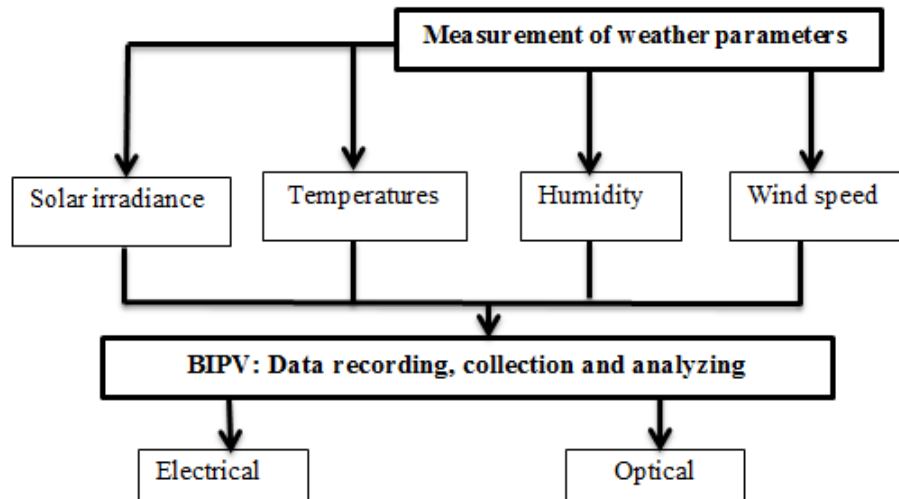

Figure 14: Conceptual framework of the proposed research approach.

3.2 Experimental set up

3.2.1 Layout of the experimental and installation

An experimental room containing in the building has many windows, and the PV glazing was set upon one of the window facing the north. The building for experiment was Innovation Technological and Energy Center (iTEC) in one part of the facade. The building is located at Nelson Mandela African Institution of Science and Technology, commonly known as incubation center. There were some trees nearby the experimental room facing south; therefore, the tests in the evening could be influenced by shading effect that was

considered. The experimental room is constructed with bricks and painted with white colors.

The semi-transparent window PV was fixed in one of the window facing north for the replacement of the convectional material as shown in Fig. 15.



Figure 15: Fixing of the semi-transparent PV and already installed solar panel.

3.2.2 Selection of building-integrated photovoltaic modules

Double glazed monocrystalline silicon semi-transparent PV glazing module was selected and studied in the test, and was fixed on the window for its performance. Monocrystalline has been chosen over polycrystalline because it has higher efficiency; and the semi-transparent PV module has a transparent area to allow the light for penetration to improve the energy saving and occupant comfort as shown in Fig. 16. The properties of the PV glazing module, which were provided by the respective manufacturer company, are listed in Table 4.



Figure 16: Side view of in and out of the semi-transparent PV window glazing.

Table 4: Descriptions of the PV glazing considered.

Parameter	Description
PV glazing code	BSM50M
Manufacturer	Bluesun solar energy tech.co Ltd
PV solar cell type	Mono 156
Manufacturing date	April 2019
Size of the solar cells	620mm*620mm*40mm
Layers of the glazing (external to internal)	6 mm super white semi-tempered glass (low iron tempered glass)
Standard Test Condition (STC)	1000 W/m ² , A.M 1.5 and 25 °C
Open circuit voltage	5.59 V
Short circuit current	9.63 A
Voltage at maximum power (V_{mp})	4.38V
Current at maximum power (I_{mp})	8.39A
Reference output power	50 W
Operating temperature	-40 °C to +85 °C

3.3 Experimental measurement and arrangements

3.3.1 Measurement equipment and instruments

Measurement of different parameters was taken based on the local condition for good performance of the double glazed semi-transparent BIPV panel. The parameters are solar irradiance G , indoor and outdoor illuminance E_{in} and E_{tr} , air temperature T_a , module temperature T_m , relative humidity R_h , and wind speed. The field experiment and data collection were conducted for 10 hours a day from May to August 2019. The equipment includes three temperature sensors, two lux meters, two solar power meters, and 3-cup anemometer (Table 5). All data were recorded by the data logger automatically at the interval of one minute and sent to the near-by computer for the storage by using bluetooth.

Table 5: Descriptions of measurement equipment for the study

Equipment	Specification	Description
Data logger	ETO 400 CP	Data acquisition system
3-cup anemometer	AM-4836	Wind speed and directions
Fluke multimeter	FLUKE 101	Mono 156
Temperature sensors	LM35	Indoor and outdoor temperatures
Solar power meters	TES 123 USB SM-206	Solar irradiance
Lux meters	UA-961 UA-962	Indoor and outdoor illuminance
Solar battery	UNI12V/12Ah	To power data acquisition system
Variable resistor		For load variations

3.3.2 Designing data acquisition system circuit

The design of the data acquisition system involved different materials such as single sided copper clad board which is coated with copper material. It involved different electronic components such as current sensor, real time clock, microcontroller, relay, display and switch with interconnection to the electrical circuit. Soldering of the interconnecting circuit were made in the NM-AIST lab where layer of conducting material was printed on the surface of an insulating board and inserted in a drill hole. Electrical connections between the circuit components were completed by designing the circuit using Proteus 8.7 professional software. Electronic components were inserted in drilled holes through appropriate locations and then were soldered to make good contacts. The circuit was fixed in housing, the input function codes were written and fed into data acquisition system to enable device to interpret the

measured parameters. Figure 17 show the circuit layout of the data acquisition system.

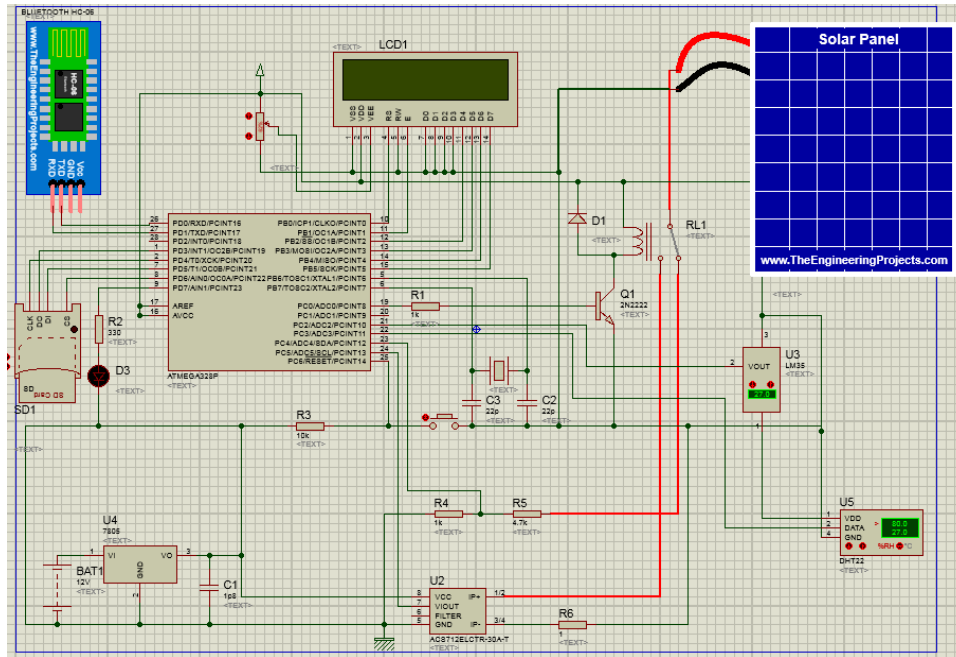

Figure 17: Circuit layout of the data acquisition system.

3.3.3 Arrangements and measurement of temperatures and humidity

The arrangement and measurements of the temperatures and humidity are shown in Fig. 18. Three temperature sensors LM 35 were used to measure the temperatures on both inside and outside surface of the PV glazing, the temperature of the module and the relative humidity. One of the sensors was connected directly to the data logger for recording room temperature (T_r) and relative humidity (R_h). The air temperature (T_a) was recorded by another sensor which was installed outside nearby the solar window glazing while the module temperature (T_m) was connected by another sensor within the surface of the window glazing. Both sensors readings were recorded and stored directly to the equipment and then downloaded to the software.



Figure 18: Arrangement and measurements of the temperatures and humidity.

3.3.4 Arrangement and measurement of solar irradiance and wind speed during a day

Two solar meters TES 132 USB and SM 206 and 3-cup anemometer were installed on each of the nearby semitransparent PV and north facing façade—and were set at 90° to horizontal plane (Fig. 18). One solar meter was installed nearby of the experimental room to the semitransparent PV and another was connected directly to the computer and being recorded. Both solar meters were used for consideration of the impact of the irradiance variation for receiving same amount of the irradiance which was captured by the panel. The readouts were taken and made comparisons for the reliability and sensitivity of the data obtained for measuring the global irradiance. Another solar meter was connected to the data logger and the exact solar irradiance data were calculated using the measured voltage. In the same days, investigation result at different solar irradiance was plotted for the comparison of the outdoor semi-transparent window glazing performance. The wind speed was measured by 3-cup anemometer and connected directly by RS 232 cables to the computer. It was installed 1.9 m from the ground and 2.5 m across the window. The data were recorded at the interval of one minute and sent to the computer for storage. The total irradiance was recorded every one minute for the period of more than three months. The measurement was done basing on three weather conditions, cloudy sky, clear sky, and normal weather conditions.

3.3.5 Arrangements of the measuring of daylight

The measurements of illuminance were obtained by two lux meters manufactured in China. One lux meter was fixed in the centre of the rear side of the semitransparent PV and at a

height of 0.54 m, to record the indoor illuminance. Another lux meter was installed near by the panel outside of the experimental room to determine the outdoor illuminance. The artificial lighting sources were switched off during the daily tests, and the illuminance data were recorded by lux meter once per minute. Day lighting was introduced indoors through the semi-transparent BIPV window. The indoor and outdoor illuminance were plotted, and results on the visible light transmittance were calculated and analyzed.

3.3.6 Arrangement and measurement of electrical performances

The semi-transparent PV was connected to a control unit consisting of an electric load (variable resistor) and the data logger. According to Fara and Craciunescu (2017), the physical arrangement of the elements of the PV cell as well as the electrical characteristics of each element enable to develop accurate equivalent circuit expressions for a PV cell.

The load resistance was connected purposely for semi-transparent PVs' electrical characteristics consideration with ammeter (A), and voltmeter (V) as shown in Figure 19 with its simplified equivalent circuit. The performance was monitored at the solar irradiances of 650 ± 10 , 810 ± 10 , 1000 ± 10 and 1100 ± 10 W/m^2 of the same day.

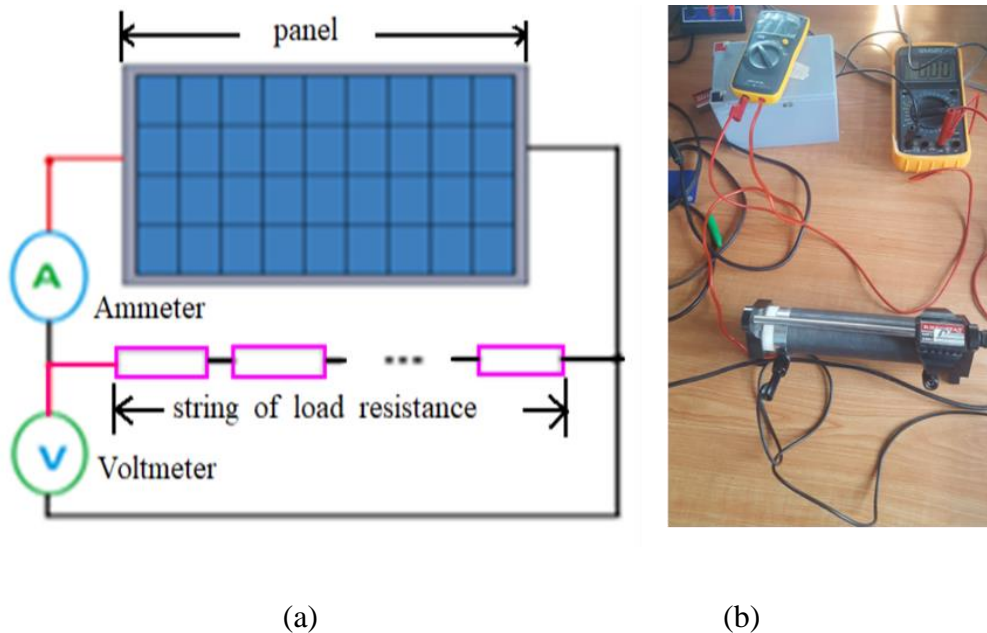

Figure 19: Equivalent circuit diagram (a) and real circuit (b) for I-V and P-V plots experimental measurements.

The current-voltage (I-V) curves were measured by digital multimeters manually within 5 minutes at each solar irradiance. The I-V and power-voltage (P-V) curves were plotted to provide important performance information about PV modules such as open circuit voltage V_{OC} , short circuit current I_{sc} , maximum rated power P_{max} , current at the maximum power I_{mp} , voltage at the maximum power V_{mp} . Then fill factor (FF) and power conversion efficiency η were calculated from the formulas (1) – (2):

$$FF = \frac{P_{max}}{V_{OC} \times I_{sc}} = \frac{I_{mp} V_{mp}}{V_{OC} I_{sc}} \quad (1)$$

$$\eta = \frac{P_{max}}{P_{in}} \quad (2)$$

Where: G is incident irradiance, W/m^2 , and A is window surface area, m^2 .

3.3.7 Arrangement and measurement of optical performances

Two lux meters were installed on each side of the semi-transparent PV and north facing facade. One lux meter was fixed at the center of the rear side of the semi-transparent PV and at a height of 0.54 m, to record the indoor illuminance. Another lux meter was installed near the panel out of the experimental room to determine the outdoor illuminance. Both lux meters were recording the transmitted and incident daylight.

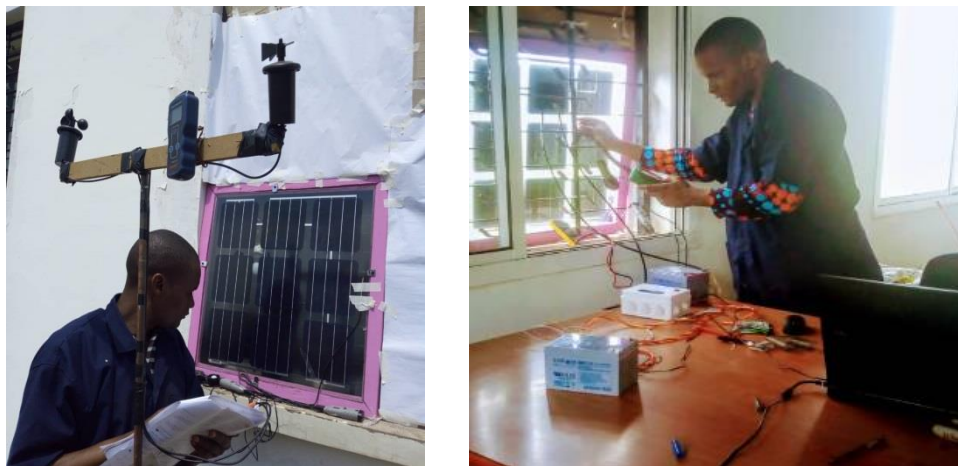

Figure 20: Measurement of transmitted and incident illuminance.

To measure the Visible Light Transmittance (VLT) day lighting was introduced into the room through the semi-transparent PV as shown in Fig. 20. The optical parameters measured were illuminances, transmitted (E_{tr}) inside the room and incident (E_{in}). The VLTs were calculated

from the formulas (3):

$$\text{VLT} = \frac{E_{tr}}{E_{in}} \quad (3)$$

CHAPTER FOUR

RESULTS AND DISCUSSION

This chapter presents data obtained from experimental analysis. Section 4.1 presents weather parameters results such as temperature variations, humidity and solar irradiations. Sections 4.2 – 4.4 present electrical and optical performance on the semi-transparent BIPV system.

4.1 Weather parameters results

Weather parameters are important factors for the performance of the solar PV window glazing. These parameters are temperatures, humidity and irradiance. Figure 21 shows the variation of the outdoor air and module temperatures on 10 July, 2019. The air and module temperatures vary from 17 to 33 °C and 23-51 °C respectively while relative humidity varies from 23 to 63% at different test conditions through the experimentations. As air temperature increases, there is great increase of the module temperature that affects the performance of the PV window glazing, the observation agrees by the author Shukla, Sudhakar and Baredar (2016). Also, effect of solar irradiance on temperatures of air T_a and the semi-transparent window glazing T_m and humidity R_h is shown in Fig. 22 as measured on 18 June, 2019. Any increase in temperatures is due to the increase of the solar irradiation, and module temperature T_m is higher than air temperature T_a by 5 °C - 15 °C. The temperatures increase gradually with increase in irradiation in the morning, but in the evening when the irradiation decreases sharply the air temperature decreases slowly while module temperature remains practically unchanged; these observation concurs to work by Selvaraj, Ghosh, Mallick and Sundaram (2019). It was observed that any drop of relative humidity correlates with increase of the irradiance; hence increase in power output where the observation agrees with data by Hassanien, Li and Yin (2018).

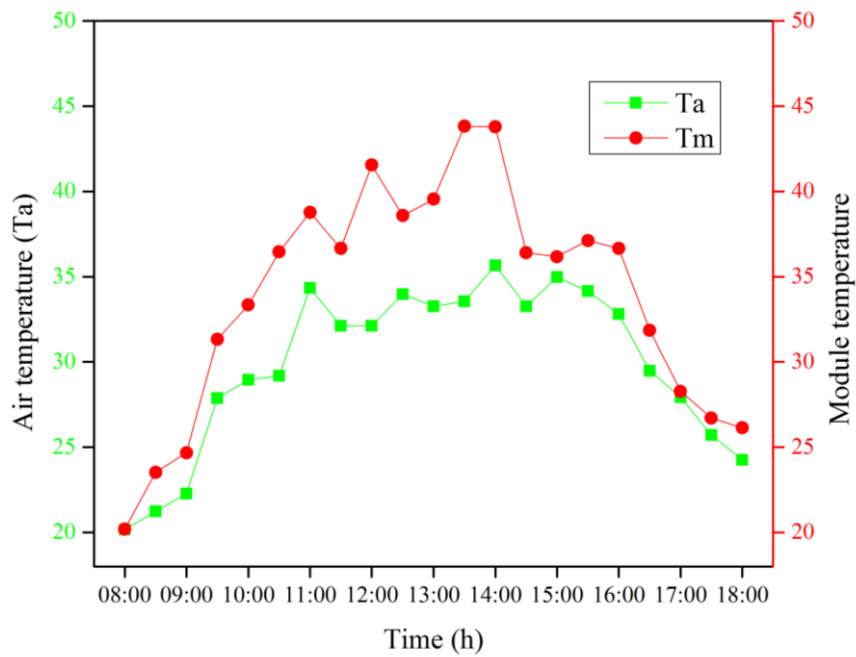

Figure 21: Variation of air temperature (T_a) and module temperature (T_m) measured on 10 July, 2019.

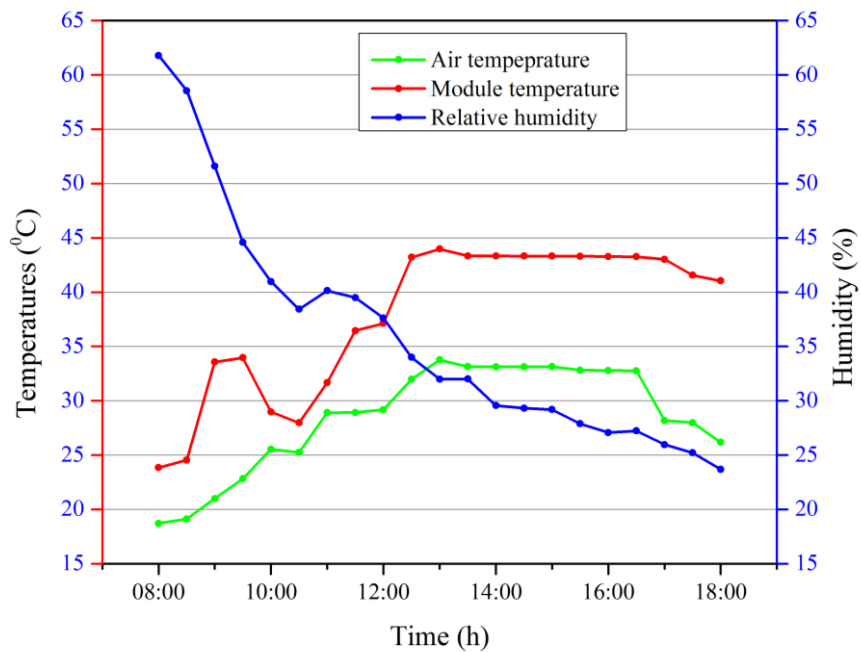

Figure 22: Variation of air temperature (T_a), module temperature (T_m) and relative humidity (R_h) measured on 18 June, 2019.

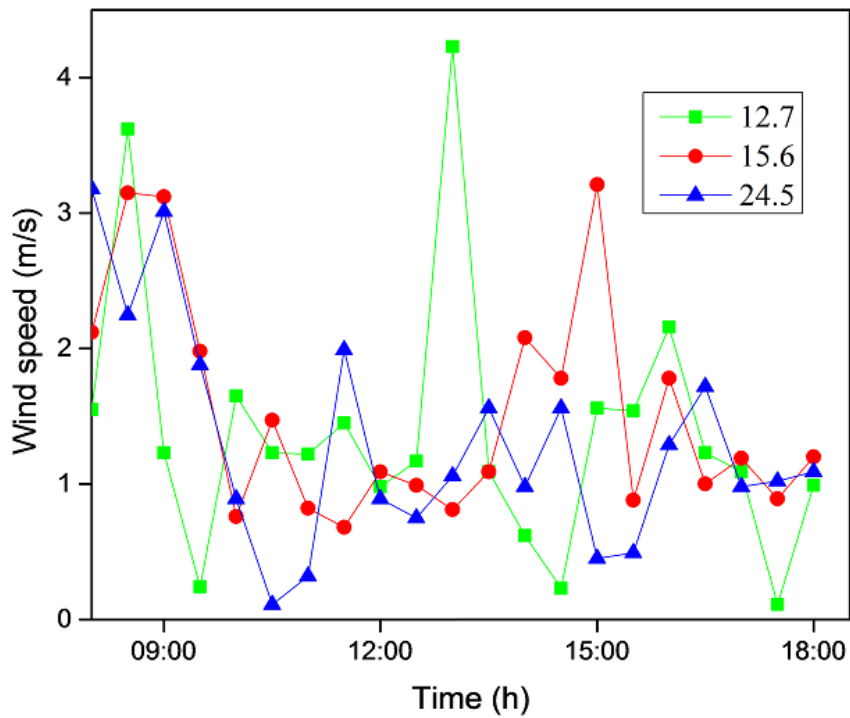

Figure 20. Variation of the wind speed at different test conditions.

Variation of the solar irradiation at different test conditions on 28 May, 2019, 10 June, 2019 and 18 July, 2019 respectively, is shown in Fig. 24. It has been observed that in clear sky the total energy produced were 6 kWh/m²/ day. Also, in normal sky, the total energy produced were 4 kWh/m²/ day while in cloudy sky, the total energy produced were only 2 kWh/m²/ day. The irradiance reduced sharply when the sun was covered by clouds and raised shortly when cleared. The solar irradiance ranges were ~ 30-450 W/m², 75-800 W/m², and 130-1350 W/m² on a cloudy, normal and clear sky days respectively, throughout the experimentations. The maximum solar irradiance at noon reached ~1350 W/m² for the whole experiment while the minimum irradiance was obtained in the evening equivalent to ~32.5 W/m². In the evening the solar radiation drops abruptly from 5 pm to 6 pm due to the shading effect. This observation agrees with the author Cheng *et al.* (2018) in climatic region of China that shading has an effect on power generation because during shading there is drop of the solar irradiance. The fluctuations for monitored parameters might be due to change in environmental conditions caused by either increased or decreased wind speed, un-prolonged cloud cover, shading impact or irradiance fluctuations. Our study observed also that there is no direct relationship on variation of the wind speed to the power generation and solar irradiance as shown in Fig. 25. Hence location of the semi-transparent BIPV in building must be considered thoroughly.

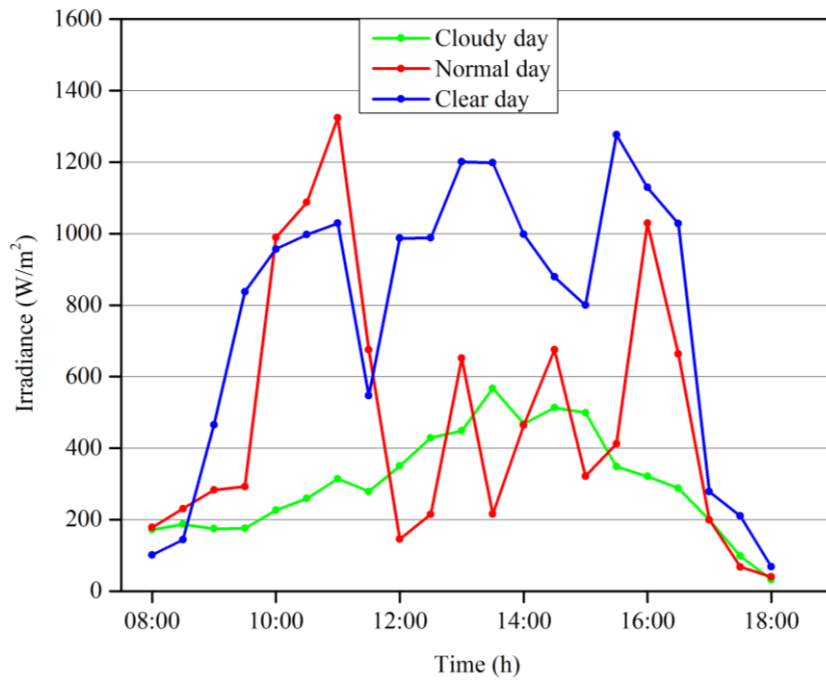

Figure 21: Variation of the solar irradiation at different test conditions.

The effect of solar irradiance on the semi-transparent window glazing is shown in Fig. 25 as measured on 18 June, 2019. Any increase in temperatures is due to the increase of the solar irradiation because of availability of the sun, but high module temperature leads the power output to decrease. The temperature increases slowly with increase in irradiation and when the irradiation decreases sharply there is slow decrease in temperatures as also concurs to Selvaraj, Ghosh, Mallick and Sundaram (2019).

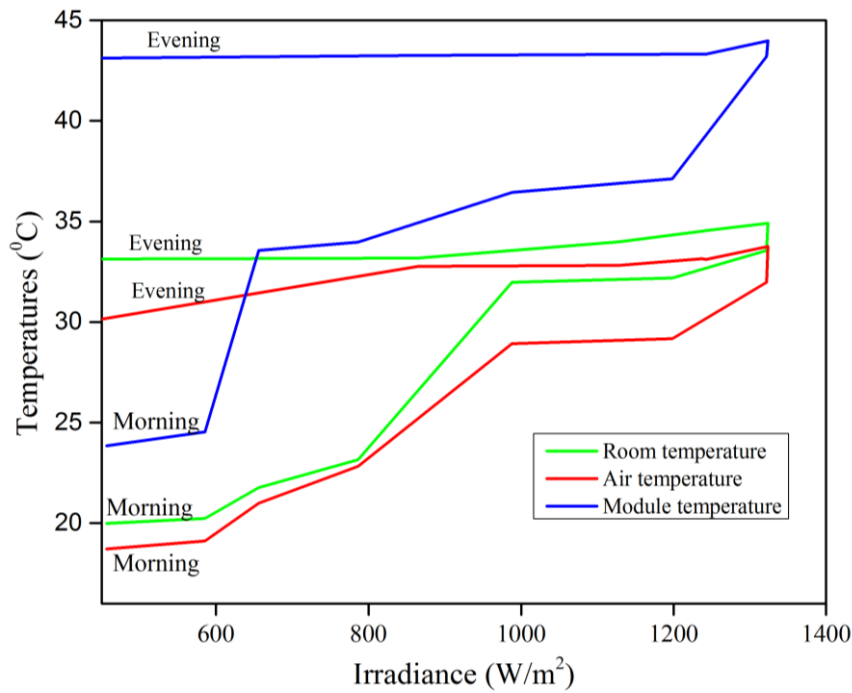

Figure 22: Temperature of the panel (T_m), and air inside (T_r) and outside (T_a) of the building versus solar irradiance G during a day.

4.2 Electrical performance

This section presents semi-transparent BIPV modules' performance under a set of realistic conditions. Figure 26 shows the electrical characteristics (I-V and P-V) curves measured at different irradiances. From the curves, the open circuit voltage (V_{oc}), short circuit current (I_{sc}), were obtained; the efficiency and fill factor were calculated from the formulas (1) and (2); electrical performance parameters are summarized in Table 6. The maximum efficiency obtained was 8.9% at irradiance of 1000 W/m^2 and temperature $T_m = 32 \text{ }^\circ\text{C}$, which was equivalent to the manufacturer's efficiency, while at 1100 W/m^2 efficiency decreased to 5.8% with increase the module temperature to $47 \text{ }^\circ\text{C}$. The results agree with other studies of semi-transparent BIPV performed in tropics of Spain and China, respectively, that with increasing temperature T_m , the current I_{sc} increases while the V_{oc} and P_{max} decrease (Chemisana *et al.*, 2019). Figure 27 shows the correlation of fill factor and efficiency with solar irradiance.

Table 6: Results of electrical measurements investigating effects of irradiance and temperature.

Irradiance G (W m ⁻²)	Open circuit voltage, V _{oc} (V)	Short circuit current, I _{sc} (A)	Maximum power, P _{max} (W)	Fill Factor, FF (%)	Efficiency, η (%)	Module temperature T _m (°C)
650	5.4	4.6	16.3	64.4	8.6	41.9
810	5.5	5.3	19.6	67.5	8.3	42.2
1000	6.2	6.5	25.9	63.2	8.9	32.2
1100	5.3	5.6	18.5	48.9	5.8	46.7

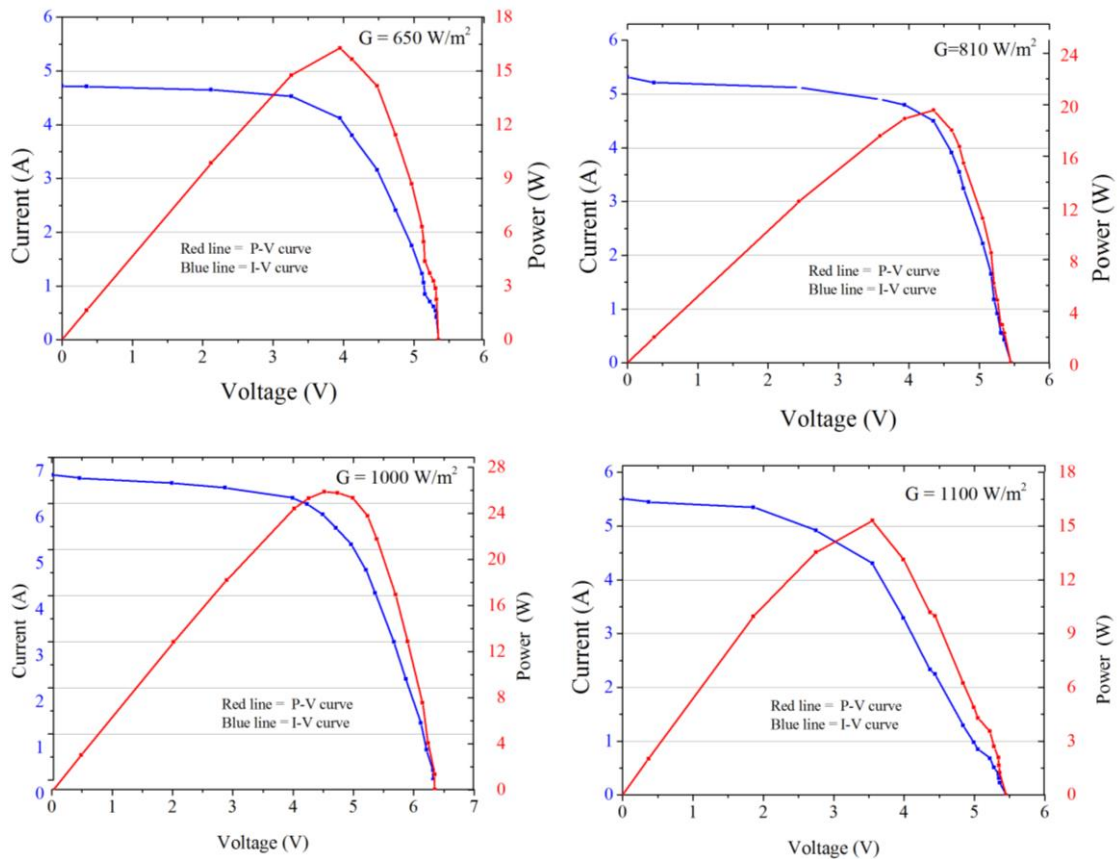

Figure 23: The semi-transparent solar panel performance at different irradiances: I-V curves and P-V curves.

The variation of power versus solar irradiation obtained through recording of voltage and current operating during a day is shown in Fig. 27. The power generated apparently depends on the solar irradiation, the higher the solar irradiations the higher the output power depending also on other factors such as module temperature. From Table 6, the solar PV glazing window produced more power from the irradiance 600 W/m² up to 1000 W/m² in a day with normal module temperature between 25 – 33 °C as compared to that at STC from

the manufacturer. With G increase the P_m increases, but up to some limit, until temperature rise brings to drop in P_m as happened at $G = 1100 \text{ Wm}^{-2}$ and $T_m = 47 \text{ }^\circ\text{C}$; here inspite of higher G , the P_m appeared lower than at $G = 1000 \text{ Wm}^{-2}$ and $T_m = 32 \text{ }^\circ\text{C}$; and that is apparently the temperature impact overcomes that of G . When there is high temperature, with no regardless of the high irradiance, the power drops due to high heating of the panel. This was also verified by Sánchez-Palencia, Martín-Chivelet and Chenlo, (2019). Through the regression analysis, the correlation coefficient (R^2) was found to be 0.8243; this confirms a direct mutual correlation between power generated and solar irradiance.

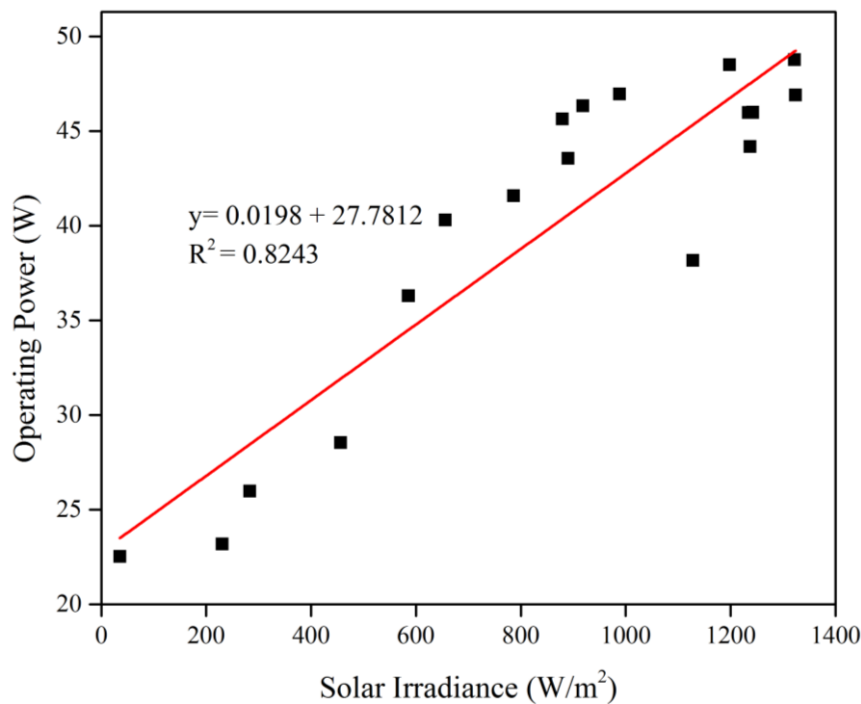

Figure 24: Correlation between power generated and solar irradiance.

4.3 Optical performance

Optical measurements were performed to obtain the visible light transmittance (VLT) through the semi-transparent BIPV modules. All readings obtained were recorded using data logger. The VLT was calculated by dividing the readings with transmitted light (E_{tr}) with the the illuminated light (E_{in}) using formula (3). To ensure the accuracy of measurement results, recordings were performed on different days. The average values were then used for the VLT calculation as shown in Table 7.

Table 7: An example of daily measured optical parameters

Time	Illuminance (kLux)		VLT
	Transmitted (E_{tr})	Incident (E_{in})	E_{tr} / E_{in}
9:00	5.23	44.86	0.12
11:00	8.99	62.12	0.14
13:00	13.65	77.12	0.18
15:00	15.61	87.87	0.18

The visible light transmittance of the semitransparent window is the important parameter for the passive daylight. Figure 28 (a) shows the plots of incident and transmitted daylight illuminance through the semi-transparent PV as the daily profile measured in the clear sky on 26 July, 2019. The maximum daylight illuminance was 119 kLux while the corresponding transmitted illuminance was 23 kLux. This represents maximum VLT of 19% whereas the VLT range of the semi-transparent BIPV module is 11–19%. The values agree with results by other researchers (Chae, Kim, Park & Shin, 2014; Meng, Jinqing, Hongxing & Yimo, 2018), where the VLT values for semi-transparent BIPVs were obtained 2% - 37% in the tropics of China. The result shows that increase in illuminance is due to increase of the irradiance; the illumination also is affected by other factors such as temperature and wind. Figure 28 (b) shows the transmitted illuminance through the semi-transparent PV panel against the incident daylight illuminance. In this plot there is good correlation coefficient (R^2) of 0.9794. This result shows that the VLT of the glazing window was approximately equal to 19%. Table 8 shows monthly VLT measurement results of semi-transparent BIPV modules for the complete experiment.

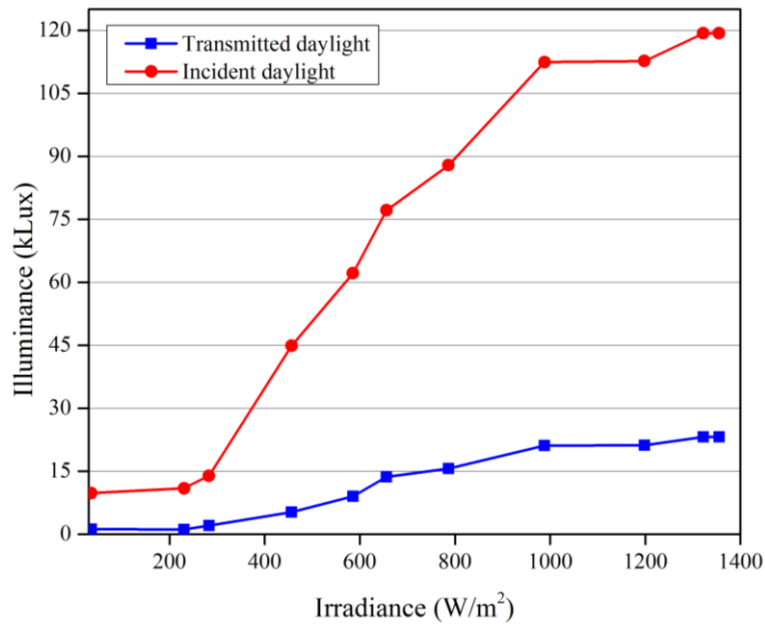

(a)

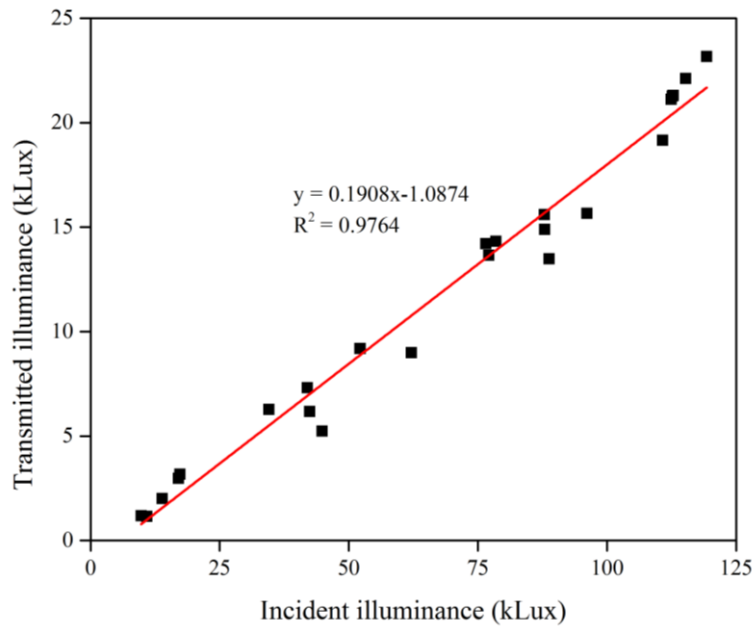

(b)

Figure 25: (a) Variation of the illuminance, transmitted inside the building (E_{tr}) and incident (E_{in}), versus irradiance and (b) Relationship between the E_{tr} and E_{in} .

Table 8: Monthly VLT measurement results of semi-transparent BIPV module.

Date of the experiment: 21 May, 2019 – 20 August, 2019			
Average Illuminance (kLux) in each month			
Month	Transmitted (E_{tr})	Incident (E_{in})	Average VLT (%)
May	6.18	42.41	15
June	14.89	87.92	17
July	23.17	119.21	19
August	21.34	112.65	19
Overall VLT for the whole experiment			17.5

CHAPTER FIVE

CONCLUSION AND RECOMMENDATIONS

This research study investigated semi-transparent BIPV applications for commercial buildings in the tropics in two key phases: (1) Measuring of weather parameters in tropical area and (2) Analyzing electrical and optical performance of semi-transparent BIPV system in the area. In this chapter, the fundamental findings are summarized. Also, the recommendations for future research are highlighted.

5.1 Conclusion

Semitransparent BIPV is a smart energy generation approach that integrates photovoltaic technologies into buildings to harvest abundant solar energy in various forms. It is considered to be among the promising renewable energy technologies of the future since its discoveries in the 1970. The results of this study revealed the following important findings:

Electrical parameters analysis shows that performance efficiency of the semi-transparent PV under real condition decreases with increasing of the module temperature. Maximum efficiency obtained at irradiance of 1000 W/m^2 and the panel temperature of $32 \text{ }^\circ\text{C}$ was 8.9%, which was equivalent to the manufacturer's efficiency, while at 1100 W/m^2 efficiency decreased up to 5.8% with temperature rise to $47 \text{ }^\circ\text{C}$. Therefore the electrical energy efficiency of the semi-transparent PV panel increases with the increase in solar irradiation up to reaching the highest point, but decreases at the high panel temperature.

Shading has impacts on the power production for the semi-transparent modules. Experiment showed that every day at 5 pm there was great reduction of the power as well as the solar irradiation due to shading. Hence proper location of the BIPV with consideration of shading has to be considered to avoid this problem. However the shading affects slowly the fall of the panel temperature:-

Optical measurements were conducted to obtain the VLT of the semi-transparent modules. The semi-transparent window glazing possesses the visible light transmittance of 11-19% and produces good indoor environmental visual comfort for occupants. So semi-transparent window glazing is recommended for the Arusha tropics and other sub-Saharan areas with the

same conditions.

5.2 Recommendations

In various countries the BIPVs are widely implemented due to their advantages and also due to government support and customers awareness, hence there is a great need for government supports to get the industry started as it has been carried out with accomplishment in European countries. However, in Tanzania and other tropical countries, the BIPVs are rarely used up to now. Due to the large amount of solar radiation, semitransparent BIPV systems are very well suited for energy generation as shown in chapter four and they will possibly play a significant role in the future energy generation. New technologies under improvement will in the future provide semi-transparent BIPVs with better efficiencies and decrease production costs. Some of the new concepts relate to the third generation of organic-based PVs, consisting of dye-sensitized and TiO₂ solar cells; and solution concerns also awareness of stakeholders and growing the market share. The following are recommendations in few areas of future research that could possibly be helpful on the way to the implementation of BIPV.

More studies have to be conducted for investigation of the impact of low visible light transmission, low solar heat gain coefficient and high u-values of the semi-transparent window glazing on the health of occupants and also their behavior and feelings towards implementing renewable energy. Such studies can also consider occupants' comfort such as thermal comfort and glare.

This research has assumed that only semi-transparent photovoltaic modules are adopted to replace traditional window glazing. Further research can consider transparent and opaque BIPV modules of various transmittances to obtain the best energy result and occupants' satisfaction.

An investigation of possible barriers and awareness to adoption of the BIPV from different stakeholders such as architects, designers and engineers regarding design and implementation of BIPV modules are also recommended to be conducted. These barriers and awareness to adoption can affect the selection outcome and final costs of BIPV systems and guide the future direction of BIPV architectural design.

REFERENCES

- Agathokleous, R. A., Kalogirou, S. A., & Karellas, S. (2018). Exergy analysis of a naturally ventilated Building Integrated Photovoltaic/Thermal (BIPV/T) system. *Renewable Energy*, 128, 541-552. doi: 10.1016/j.renene.2017.06.085
- Agrawal, B., & Tiwari, G. (2010). Optimizing the energy and exergy of building integrated photovoltaic thermal (BIPVT) systems under cold climatic conditions. *Applied Energy*, 87(2), 417-426. doi: 10.1016/j.apenergy.2009.06.011
- Ahmed, O. K., Hamada, K. I., & Salih, A. M. (2019). Performance analysis of PV/Trombe with water and air heating system: an experimental and theoretical study. *Energy Sources, Part A: Recovery, Utilization, and Environmental Effects*, 1-21. doi: 10.1080/15567036.2019.1650139
- Azadian, F., & Radzi, M. (2013). A general approach toward building integrated photovoltaic systems and its implementation barriers: A review. *Renewable and Sustainable Energy Reviews*, 22, 527-538. doi: 10.1016/j.rser.2013.01.056
- Baljiti, S., Chan, H.-Y., & Sopian, K. (2016). Review of building integrated applications of photovoltaic and solar thermal systems. *Journal of Cleaner Production*, 137, 677-689. doi: 10.1016/j.jclepro.2016.07.150
- Ban-Weiss, G., Wray, C., Delp, W., Ly, P., Akbari, H., & Levinson, R. (2013). Electricity production and cooling energy savings from installation of a building-integrated photovoltaic roof on an office building. *Energy and Buildings*, 56, 210-220. doi: 10.1016/j.enbuild.2012.06.032
- Basnet, A. (2012). *Architectural integration of photovoltaic and solar thermal collector systems into buildings*. (Masters Thesis), Norwegian University of Science and Technology, Trondheim. Retrieved from <https://pdfs.semanticscholar.org/5243/a1376b8a7dd2d.pdf>
- Bishoge, O., Zhang, L., & Mushi, W. (2018). The potential renewable energy for sustainable development in Tanzania: A Review. *Clean Technologies*, 1(1), 70-88. doi: 10.3390/cleantechnol1010006

- Biyik, E., Araz, M., Hepbasli, A., Shahrestani, M., Yao, R., Shao, L., . . . technology, a. i. j. (2017). A key review of building integrated photovoltaic (BIPV) systems. *International Journal of Exergy*, 20(3), 833-858. doi: 10.1016/j.jestch.2017.01.009
- Boden, T. A., Marland, G., & Andres, R. J. (2009). Global, regional, and national fossil-fuel CO₂ emissions. *Carbon Dioxide Information Analysis Center, Oak Ridge National Laboratory, US Department of Energy, Oak Ridge, Tenn., USA*. 34, 1751-2007. doi: 10.3334/CDIAC/00001_V2010
- Bücher, K. (1997). Site dependence of the energy collection of PV modules. *Solar Energy Materials and Solar Cells*, 47(1-4), 85-94. doi: 10.1016/S0927-0248(97)00028-7
- Caamaño-Martín, E., Laukamp, H., Jantsch, M., Erge, T., Thornycroft, J., De Moor, H., . . . Gaiddon, B. (2008). Interaction between photovoltaic distributed generation and electricity networks. *Progress in Photovoltaics: Research and Applications*, 16(7), 629-643. doi: 10.1002/pip.845
- Chae, Y. T., Kim, J., Park, H., & Shin, B. (2014). Building energy performance evaluation of building integrated photovoltaic (BIPV) window with semi-transparent solar cells. *Applied Energy*, 129, 217-227
- Chemisana, D., Moreno, A., Polo, M., Aranda, C., Riverola, A., Ortega, E., . . . Cot, A. (2019). Performance and stability of semitransparent OPVs for building integration: A benchmarking analysis. *Renewable Energy*, 137, 177-188. doi: 10.1016/j.renene.2018.03.073
- Cheng, Y., Gao, M., Dong, J., Jia, J., Zhao, X., & Li, G. (2018). Investigation on the daylight and overall energy performance of semi-transparent photovoltaic facades in cold climatic regions of China. *Applied Energy*, 232, 517-526. doi: 10.1016/j.apenergy.2018.10.006
- Debbarma, M., Sudhakar, K., & Baredar, P. (2017a). Comparison of BIPV and BIPVT: A review. *Resource-Efficient Technologies*, 3(3), 263-271. doi: 10.1016/j.refffit.2016.11.013

- Debbarma, M., Sudhakar, K., & Baredar, P. (2017b). Thermal modeling, exergy analysis, performance of BIPV and BIPVT: A Review. *Renewable and Sustainable Energy Reviews*, 73, 1276-1288. doi: 10.1016/j.rser.2017.02.035
- Defaix, P., Van Sark, W., Worrell, E., & de Visser, E. (2012). Technical potential for photovoltaics on buildings in the EU-27. *Solar Energy*, 86(9), 2644-2653. doi: 10.1016/j.solener.2012.06.007
- Deng, W., Ye, F., Xiong, Z., Chen, D., Guo, W., Chen, Y., . . . Verlinden, P. J. (2016). Development of high-efficiency industrial p-type multi-crystalline PERC solar cells with efficiency greater than 21%. *Energy Procedia*, 92, 721-729. doi: 10.1016/j.egypro.2016.07.050
- Dharmadasa, I. (2018). *Advances in thin-film solar cells*, Temasek Boulevard, Singapore, Jenny Stanford
- Didoné, E. L., & Wagner, A. (2013). Semi-transparent PV windows: A study for office buildings in Brazil. *Energy and Buildings*, 67, 136-142. doi: 10.1016/j.enbuild.2013.08.002
- dos Santos, Í. P., & Rüther, R. (2012). The potential of building-integrated (BIPV) and building-applied photovoltaics (BAPV) in single-family, urban residences at low latitudes in Brazil. *Energy and Buildings*, 50, 290-297. doi: 10.1016/j.enbuild.2012.03.052
- Ekoe, A., Akata, A., Njomo, D., & Agrawal, B. (2015). Thermal energy optimization of building integrated semi-transparent photovoltaic thermal systems. *International Journal Renewable Energy Development*, 4(2), 113-123. doi: 10.14710/ijred.4.2.113-123
- El Tayyan, A. A. (2011). PV system behavior based on datasheet. *Journal of Electron Devices*, 9(20011), 335-341. doi: 10.1.1.666.3255
- Goh, K., Yap, A., Goh, H., Seow, T., & Toh, T. (2015). Awareness and Initiatives of Building Integrated Photovoltaic (BIPV) implementation in Malaysian Housing Industry. *Procedia Engineering*, 118, 1052-1059. doi: 10.1016/j.proeng.2015.08.548

- Green, M. A., Dunlop, E. D., Levi, D. H., Hohl-Ebinger, J., Yoshita, M., & Ho-Baillie, A. W. (2019). Solar cell efficiency tables (version 54). *Progress in Photovoltaics: Research and Applications*, 27(NREL/JA-5K00-74116), 565-575. doi: 10.1002/pip.3171
- Green, M. A., Hishikawa, Y., Dunlop, E. D., Levi, D. H., Hohl-Ebinger, J., & Ho-Baillie, A. W. (2018). Solar cell efficiency tables (version 52). *Progress in Photovoltaics: Research and Applications*, 26(7), 427-436. doi: 10.1002/pip.3040
- Green, M. A., Hishikawa, Y., Warta, W., Dunlop, E. D., Levi, D. H., Hohl-Ebinger, J., & Ho-Baillie, A. W. (2017). Solar cell efficiency tables (version 50). *Progress in Photovoltaics: Research and Applications*, 25(7), 668-676. doi: 10.1002/pip.2909
- Hadavinia, H., & Singh, H. (2019). Modelling and experimental analysis of low concentrating solar panels for use in building integrated and applied photovoltaic (BIPV/BAPV) systems. *Renewable Energy*, 139, 815-829. doi: 10.1016/j.renene.2019.02.121
- Halme, J., & Mäkinen, P. (2019). Theoretical efficiency limits of ideal coloured opaque photovoltaics. *Energy & Environmental Science*, 12(4), 1274-1285. doi: 10.1039/C8EE03161D
- Hassanien, E., Li, M., & Yin, F. (2018). The integration of semi-transparent photovoltaics on greenhouse roof for energy and plant production. *Renewable Energy*, 121, 377-388. doi: 10.1016/j.renene.2018.01.044
- Heinstein, P., Ballif, C., & Perret-Aebi, L.E. J. G. (2013). Building integrated photovoltaics (BIPV): Review, Potentials, Barriers and Myths. 3(2), 125-156. doi: 10.1515/green-2013-0020
- Ibn-Mohammed, T., Koh, S., Reaney, I., Acquaye, A., Schileo, G., Mustapha, K., & Greenough, R. (2017). Perovskite solar cells: An integrated hybrid lifecycle assessment and review in comparison with other photovoltaic technologies. *Renewable and Sustainable Energy Reviews*, 80, 1321-1344. doi: 10.1016/j.rser.2017.05.095

- Infield, D., Eicker, U., Fux, V., Mei, L., & Schumacher, J. (2006). A simplified approach to thermal performance calculation for building integrated mechanically ventilated PV facades. *Building and Environment*, *41*(7), 893-901. doi: 10.1016/j.buildenv.2005.04.010
- Jelle, P., Breivik, C., & Røkenes, H. D. (2012). Building integrated photovoltaic products: A state-of-the-art review and future research opportunities. *Solar Energy Materials and Solar Cells*, *100*, 69-96. doi: 10.1016/j.solmat.2011.12.016
- Joseph, B., Pogrebnaya, T., & Kichonge, B. (2019). Semitransparent Building-Integrated Photovoltaic: Review on Energy Performance, Challenges, and Future Potential. *International Journal of Photoenergy*, *2019*, 17. doi: 10.1155/2019/5214150
- Kant, K., Pitchumani, R., Shukla, A., & Sharma, A. (2019). Analysis and design of air ventilated building integrated photovoltaic (BIPV) system incorporating phase change materials. *Energy Conversion and Management*, *196*, 149-164. doi: 10.1016/j.enconman.2019.05.073
- Kapsis, K., & Athienitis, A. K. (2015). A study of the potential benefits of semi-transparent photovoltaics in commercial buildings. *Solar Energy*, *115*, 120-132. doi: 10.1016/j.solener.2015.02.016
- Kato, T., Wu, L., Hirai, Y., Sugimoto, H., & Bermudez, V. (2018). Record efficiency for thin-film polycrystalline solar cells up to 22.9% achieved by Cs-treated Cu (In, Ga) (Se, S) 2. *IEEE Journal of Photovoltaics*, *9*(1), 325-330. doi: 10.1109/JPHOTOV.2018.2882206
- Kha, N. P. (2013). *Semi-Transparent Building-Integrated Photovoltaic (BIPV) Windows for the Tropics*. (PhD Thesis). Retrieved from <http://scholarbank.nus.edu.sg/handle/10635/49121>
- Kichonge, B. (2018). The Status and Future Prospects of Hydropower for Sustainable Water and Energy Development in Tanzania. *Journal of Renewable Energy*, *2018*, 12. doi: 10.1155/2018/6570358

- Kim, H., Kim, R., & Kim, T. (2015). Analysis of photovoltaic applications in zero energy building cases of IEA SHC/EBC task 40/annex 52. *Sustainability*, 7(7), 8782-8800. doi: 10.3390/su7078782
- Kumar, N. M., Reddy, P. R. K., & Praveen, K. (2017). Optimal energy performance and comparison of open rack and roof mount mono c-Si photovoltaic Systems. *Energy Procedia*, 117, 136-144. doi: 10.1016/j.egypro.2017.05.116
- Kumar, N. M., Sudhakar, K., & Samykano, M. (2019). Performance comparison of BAPV and BIPV systems with c-Si, CIS and CdTe photovoltaic technologies under tropical weather conditions. *Case Studies in Thermal Engineering*, 13, 100374. doi: 10.1016/j.csite.2018.100374
- Lee, T. D., & Ebong, A. U. (2017). A review of thin film solar cell technologies and challenges. *Renewable and Sustainable Energy Reviews*, 70, 1286-1297. doi: 10.1016/j.rser.2016.12.028
- Liu, H. M., Young, C. H., Horng, D. J., Shiue, Y. C., & Lee, S.-K. (2016). Improving the performance of a semitransparent BIPV by using high-reflectivity heat insulation film. *International Journal of Photoenergy*, 2016, 15. doi: 10.1155/2016/4174216
- Mei, L., Infield, D., Gottschalg, R., Loveday, D., Davies, D., & Berry, M. (2009). Equilibrium thermal characteristics of a building integrated photovoltaic tiled roof. *Solar Energy*, 83(10), 1893-1901. doi: 10.1016/j.solener.2009.07.002
- Meng, W., Jinqing, P., Hongxing, Y., & Yimo, L. (2018). Performance evaluation of semi-transparent CdTe thin film PV window applying on commercial buildings in Hong Kong. *Energy Procedia*, 152, 1091-1096. doi: 10.1016/j.egypro.2018.09.131
- Mousa, O. (2014). *BIPV/BAPV Barriers to Adoption: Architects' Perspectives from Canada and the United States*. University of Waterloo. Retrieved from <http://hdl.handle.net/10012/8364>

- Nagano, K., Mochida, T., Shimakura, K., Murashita, K., & Takeda, S. (2003). Development of thermal-photovoltaic hybrid exterior wallboards incorporating PV cells in and their winter performances. *Solar Energy Materials and Solar Cells*, 77(3), 265-282. doi: 10.1016/S0927-0248(02)00348-3
- Nasr, A. (2013). Theoretical study of the photocurrent performance into quantum dot solar cells. *Optics & Laser Technology*, 48, 135-140. doi: 10.1016/j.optlastec.2012.10.014
- NBS, (2016). Energy-access-situation-report-2016-tanzania-mainland. Retrieved March 21, 2019, from file:///C:/Users/Benedicto/Downloads/0309_20042017-Energy _Access_ Situation_Report_Feb2017.pdf
- Nepal, R. (2012). Roles and potentials of renewable energy in less-developed economies: The case of Nepal. *Renewable and Sustainable Energy Reviews*, 16(4), 2200-2206. doi: 10.1016/j.rser.2012.01.047
- Nussbaumer, P., Bazilian, M., & Modi, V. (2012). Measuring energy poverty: Focusing on what matters. *Renewable and Sustainable Energy Reviews*, 16(1), 231-243. doi: 10.1016/j.rser.2011.07.150
- Oulmi, N., Bouloufa, A., Benhaya, A., & Mayouche, R. (2019). CuIn 0.7 Ga 0.3 Se 2 thin films' properties grown by close-spaced vapor transport technique for second-generation solar cells. *Materials for Renewable and Sustainable Energy*, 8(3), 13. doi: 10.1007/s40243-019-0151-2
- Pavlović, T. M., Radonjić, I. S., Milosavljević, D. D., & Pantić, L. S. (2012). A review of concentrating solar power plants in the world and their potential use in Serbia. *Renewable and Sustainable Energy Reviews*, 16(6), 3891-3902. doi: 10.1016/j.rser.2012.03.042
- Peng, J., Curcija, D. C., Lu, L., Selkowitz, S. E., Yang, H., & Zhang, W. (2016). Numerical investigation of the energy saving potential of a semi-transparent photovoltaic double-skin facade in a cool-summer Mediterranean climate. *Applied Energy*, 165, 345-356. doi: 10.1016/j.apenergy.2015.12.074

- Peron, F., Rat-Fischer, L., Lalot, M., Nagle, L., & Bovet, D. (2011). Cooperative problem solving in African grey parrots (*Psittacus erithacus*). *Animal Cognition*, *14*(4), 545-553. doi: 10.1007/s10071-011-0389-2
- Petrichenko, K., Ürge-Vorsatz, D., & Cabeza, L. F. (2019). Modeling global and regional potentials for building-integrated solar energy generation. *Energy and Buildings*. doi: 10.1016/j.enbuild.2019.06.024
- Radmehr, M., Willis, K., & Kenechi, U. E. (2014). A framework for evaluating WTP for BIPV in residential housing design in developing countries: A case study of North Cyprus. *Energy Policy*, *70*, 207-216. doi: 10.1016/j.enpol.2014.03.041
- Saadon, S., Gaillard, L., Giroux-Julien, S., & Ménézo, C. (2016). Simulation study of a naturally-ventilated building integrated photovoltaic/thermal (BIPV/T) envelope. *Renewable Energy*, *87*, 517-531. doi: 10.1016/j.renene.2015.10.016
- Sai, H., Matsui, T., Koida, T., Matsubara, K., Kondo, M., Sugiyama, S., . . . Yoshida, I. (2015). Triple-junction thin-film silicon solar cell fabricated on periodically textured substrate with a stabilized efficiency of 13.6%. *Applied Physics Letters*, *106*(21), 213902. doi: 10.1063/1.4921794
- Sánchez-Palencia, P., Martín-Chivelet, N., & Chenlo, F. (2019). Modeling temperature and thermal transmittance of building integrated photovoltaic modules. *Solar Energy*, *184*, 153-161. doi: 10.1016/j.solener.2019.03.096
- Selvaraj, P., Ghosh, A., Mallick, T. K., & Sundaram, S. (2019). Investigation of semi-transparent dye-sensitized solar cells for fenestration integration. *Renewable Energy*, *141*, 516-525. doi: 10.1016/j.renene.2019.03.146
- Shukla, A., Sudhakar, K., & Baredar, P. (2016). Exergetic analysis of building integrated semitransparent photovoltaic module in clear sky condition at Bhopal India. *Case Studies in Thermal Engineering*, *8*, 142-151. doi: 10.1016/j.csite.2016.06.009
- Shukla, A., Sudhakar, K., & Baredar, P. (2016). A comprehensive review on design of building integrated photovoltaic system. *Energy and Buildings*, *128*, 99-110. doi: 10.1016/j.enbuild.2016.06.077

- Shukla, A., Sudhakar, K., & Baredar, P. (2017). Recent advancement in BIPV product technologies: A Review. *Energy and Buildings*, *140*, 188-195. doi: 10.1016/j.enbuild.2017.02.015
- Shukla, A., Sudhakar, K., Baredar, P., & Mamat, R. (2017). BIPV in Southeast Asian countries—opportunities and challenges. *Renewable Energy Focus*, *21*, 25-32. doi: 10.1016/j.ref.2017.07.001
- Shukla, A., Sudhakar, K., Baredar, P., & Mamat, R. (2018). Solar PV and BIPV system: Barrier, challenges and policy recommendation in India. *Renewable and Sustainable Energy Reviews*, *82*, 3314-3322. doi: 10.1016/j.rser.2017.10.013
- Shukla, A., Rangnekar, S., & Sudhakar, K. (2015). A comparative study of exergetic performance of amorphous and polycrystalline solar PV modules. *International Journal of Exergy*, *17*(4), 433-455. doi: 10.1504/IJEX.2015.071559
- Skaaland, Å., Ricke, M., Wallevik, K., & Strandberg, R. (2011). Potential and Challenges for Building Integrated Photo-voltaics in the Agder Region. *Agderforskning, Kristiansand*.
- Sorgato, M., Schneider, K., & Rüther, R. (2018). Technical and economic evaluation of thin-film CdTe building-integrated photovoltaics (BIPV) replacing façade and rooftop materials in office buildings in a warm and sunny climate. *Renewable Energy*, *118*, 84-98. doi: 10.1016/j.renene.2017.10.091
- Vats, K., & Tiwari, G. (2012). Performance evaluation of a building integrated semitransparent photovoltaic thermal system for roof and façade. *Energy and Buildings*, *45*, 211-218. doi: 10.1016/j.enbuild.2011.11.008
- Wong, P. W., Shimoda, Y., Nonaka, M., Inoue, M., & Mizuno, M. (2008). Semi-transparent PV: Thermal performance, power generation, daylight modelling and energy saving potential in a residential application. *Renewable Energy*, *33*(5), 1024-1036. doi: 10.1016/j.renene.2007.06.016

- Yang, T. (2015). *A Numerical and Experimental Investigation of Enhanced Open-Loop Air-Based Building-integrated Photovoltaic/Thermal (BIPV/T) Systems*. (PhD Thesis), Concordia University, Montreal, Quebec, Canada. Retrieved from https://spectrum.library.concordia.ca/980014/1/Yang_PhD_S2015.pdf
- Yoo, S.-H., Lee, E. T., & Lee, J. K. (1998). Building integrated photovoltaics: a Korean case study. *Solar energy*, *64*(4-6), 151-161. doi: 10.1016/S0038-092X(98)00115-7
- Yoo, S. H., & Manz, H. (2011). Available remodeling simulation for a BIPV as a shading device. *Solar Energy Materials and Solar Cells*, *95*(1), 394-397. doi: 10.1016/j.solmat.2010.02.015
- Zogou, O., & Stapountzis, H. (2012). Flow and heat transfer inside a PV/T collector for building application. *Applied Energy*, *91*(1), 103-115. doi: 10.1016/j.apenergy.2011.09.019
- Zomer, C. D., Costa, M. R., Nobre, A., & Rüther, R. (2013). Performance compromises of building-integrated and building-applied photovoltaics (BIPV and BAPV) in Brazilian airports. *Energy and Buildings*, *66*, 607-615. doi: 10.1016/j.enbuild.2013.07.076