

**AN ENHANCED IoT-BASED WRISTBAND FOR REMOTE  
MONITORING AND EARLY DETECTION OF HYPERTENSION  
COMPLICATIONS IN UGANDA**

**Nkoloogi Blasius**

**A Project Report Submitted in Partial Fulfillment of the Requirements of the Award of  
the Degree of Master of Science in Embedded and Mobile Systems of the Nelson  
Mandela African Institution of Science and Technology**

**Arusha, Tanzania**

**August, 2024**

## ABSTRACT

Remote monitoring systems can transform healthcare for non-communicable diseases like hypertension. Despite widespread blood pressure testing, real-time communication and record storage remain challenging in Uganda. This project developed an enhanced Internet of Things (IoT) based wristband for remote monitoring and early detection of hypertension complications. The system integrates a wearable wristband and web application to track vital signs blood pressure, heart rate, oxygen saturation, and body temperature transmitting real-time data wirelessly. It alerts patients, next of kin, and medical practitioners to critical hypertension levels, enabling early intervention against heart disease, stroke, and kidney disease. Data collection involved 243 patients and 17 medical practitioners from Rocket Health Clinic in Uganda. Qualitative methods included focus groups, observations, and analysis of Electronic Medical Records (EMR), while quantitative methods utilized patient surveys. Additional data from reports, journals, books, databases, and websites on blood pressure monitoring systems were also analyzed using Power BI. The development followed Extreme Programming (XP) agile methodology, accommodating evolving requirements under tight deadlines. Validation indicated the system is easy to use, accurate, and reliable. The wristband hardware includes the DOIT ESP32 DevKit v1 microcontroller, MKB0803 blood pressure sensor, MAX30102 pulse oximeter sensor, DS18B20 body temperature sensor, OLED SSD1306 display module, UC15 3G module, and SIM800L GSM module. The web application was developed using Laravel, Vue, Inertia, and EChart. Future work aims to enhance system accessibility regardless of smartphone or internet access, potentially through voice-based interfaces. Evaluations will extend to managing chronic diseases like diabetes, leveraging insights to improve healthcare in resource-limited settings.

## DECLARATION

I, Nkoloogi Blasius, do hereby declare to the Senate of the Nelson Mandela African Institution of Science and Technology that this project report is my original work and that it has neither been submitted nor is concurrently submitted for a degree award in any other institution.

Nkoloogi Blasius

---

**Name of Candidate**

**Signature**

**Date**

The above declaration is confirmed by:

Dr. Elizabeth Mkoba

---

**Name of Supervisor 1**

**Signature**

**Date**

Dr. Maranya Mayengo

---

**Name of Supervisor 2**

**Signature**

**Date**

## **COPYRIGHT**

This project report is copyright material protected under the Berne Convention, the Copyright Act of 1999, and other international and national enactments, on behalf, of intellectual property. It must not be produced by any means, in full or in part, except for shorts extracts in fair dealing, for researcher private study, critical scholarly review, or discourse with an acknowledgment, without the written permission of the office of Deputy Vice-Chancellor for Academic, Research, and Innovation on behalf of the author and the Nelson Mandela African Institution of Science and Technology.

## CERTIFICATION

The undersigned certify that they have read and hereby recommend for acceptance by The Nelson Mandela African Institution of Science and Technology, a project report titled “**An Enhanced IoT-Based Wristband for Remote Monitoring and Early Detection of Hypertension Complications in Uganda**” in partial fulfillment of the requirements for the degree of Master of Science in Embedded and Mobile Systems of the Nelson Mandela African Institution of Science and Technology.

Dr. Elizabeth Mkoba

---

**Name of Supervisor 1**

**Signature**

**Date**

Dr. Maranya Mayengo

---

**Name of Supervisor 2**

**Signature**

**Date**

## **ACKNOWLEDGEMENTS**

First of all, I would like to thank the Almighty God for his blessings, grace, protection, life, and guidance he has provided throughout the project period.

Secondly, I would like to express my sincere gratitude to my industrial supervisor Mr. Sowed Mutumba together with the academic supervisors; Dr. Elizabeth Mkoba and Dr. Mayengo Maranya who have moved with me throughout the process of conducting the project. I would like to thank them for their constructive guidance, and support throughout the entire process. They were always available for regular meetings and discussions, which helped me to produce this project.

I am also grateful to the Center of Excellence for East Africa (CENIT@EA) and DAAD GIZ's scholarship program for funding the project and the Nelson Mandela African Institution of Science of Technology (NM-AIST) for providing me with a facility and a conducive environment that helped me complete my project.

Finally, I would like to thank The Medical Concierge Group and Rocket Health for the permission to conduct my research study. Also, many thanks go to the team of Technology Department at Rocket Health for their technical support.

## **DEDICATION**

I dedicate this work to Dr. Joseph Tabula, Dr. Kamulegeya Louis, Mr. Isakiye Afasha, Eng. Hassan Mubiru, my brother Mr. Walusimbi Moses, and my guardians Mr. Salongo Aliddeki and Mr. Nalongo Aliddeki for their unwavering guidance, support, and prayers throughout my academic endeavors. Without their encouragement and counsel, I would not have achieved this milestone.

Additionally, I would like to express my gratitude to the Almighty for granting me the strength and good health to complete this challenging academic period.

May this work make them proud and serve as a testament to their unwavering support and glorify the One who made it all possible.

## TABLE OF CONTENTS

ABSTRACT.....	i
DECLARATION .....	ii
COPYRIGHT .....	iii
CERTIFICATION .....	iv
ACKNOWLEDGEMENTS .....	v
DEDICATION.....	vi
LIST OF TABLES.....	xi
LIST OF FIGURES .....	xii
LIST OF APPENDICES.....	xiv
LIST OF ABBREVIATIONS AND SYMBOLS .....	xv
CHAPTER ONE.....	1
INTRODUCTION .....	1
1.1 Background of the Problem .....	1
1.1.1 Normal Vital Signs.....	1
1.1.2 Essential Body Functions that Reflect Blood Pressure .....	2
1.1.3 Causes of Hypertension.....	2
1.1.4 eHealth and Digital Devices in Hypertension Management .....	3
1.1.5 Impact of Hypertension.....	3
1.1.6 Project Core Concepts .....	3
1.2 Statement of the Problem.....	4
1.3 Rationale of the Study.....	6
1.4 Project Objectives .....	6
1.4.1 General Objective.....	6
1.4.2 Specific Objectives.....	6
1.5 Research Questions .....	7

1.6	Significance of the Project .....	7
1.7	Delineation of the Study .....	8
CHAPTER TWO .....		10
LITERATURE REVIEW .....		10
2.1	Definition of Key Terms .....	10
2.2	Related Works.....	10
2.3	Technical Gap .....	14
CHAPTER THREE .....		17
MATERIALS AND METHODS.....		17
3.1	Project Case Study .....	17
3.2	Research Design.....	17
3.3	Target Population.....	18
3.4	Sampling Techniques and Sample Size .....	18
3.4.1	Sampling Techniques .....	18
3.4.2	Sample Size .....	18
3.5	Data Collection and Analysis.....	18
3.5.1	Data Collection Methods.....	19
3.5.2	Data Analysis .....	19
3.6	System Development Approach .....	19
3.6.1	Justification of the Selected Methodology .....	20
3.7	Ethical Consideration.....	21
3.7.1	Ethics.....	21
3.7.2	Regulations and Standards of Medical Devices.....	21
3.8	Chapter Summary .....	22
CHAPTER FOUR.....		23
RESULTS AND DISCUSSION .....		23

4.1	Results.....	23
4.2	Results from Questionnaire.....	23
4.2.1	Results of Analysis of the Existing Solutions .....	23
4.2.2	Results on Tracking Records After Use of Self-Testing by Patients .....	24
4.2.3	Demographic Information of Respondents .....	26
4.2.4	Results of Methods Used for Blood Pressure Testing.....	27
4.2.5	Results of Self-Testing Methods .....	28
4.2.6	Results on Challenges in Providing Health Care to Hypertension Patients ...	29
4.2.7	Results of Improvements on the Existing Solutions .....	30
4.3	Identified System Requirements .....	31
4.3.1	Functional Requirements.....	32
4.3.2	Non-functional Requirements .....	33
4.4	System Design .....	35
4.4.1	Context Diagram .....	35
4.4.2	Block Diagram .....	36
4.4.3	Circuit Design .....	37
4.4.4	Use Case Diagram.....	39
4.4.5	Flowchart Diagram.....	42
4.4.6	Database Design.....	43
4.5	System Development .....	43
4.5.1	Hardware Requirements.....	43
4.5.2	Software Requirements .....	50
4.6	System Development Results .....	56
4.6.1	Proposed System .....	56
4.6.2	Web Application Results.....	57
4.6.3	Wristband Results .....	62

4.7	System Testing Results .....	63
4.7.1	Unit Testing.....	65
4.7.2	Integration Testing .....	66
4.7.3	System Testing .....	67
4.8	System Validation Results .....	68
4.9	Discussion.....	71
CHAPTER FIVE .....		72
CONCLUSION AND RECOMMENDATIONS .....		72
5.1	Conclusion .....	72
5.1.1	Achieving Specific Objectives.....	72
5.1.2	Project Findings.....	73
5.2	Recommendations.....	73
5.2.1	Implication to the Policy Makers .....	73
5.2.2	Implication to the Practitioners .....	74
5.2.3	Implication to the Patients.....	74
5.2.4	Future Works.....	74
REFERENCES .....		75
APPENDICES .....		81

## LIST OF TABLES

Table 1:	Blood pressure stages and ranges of diastolic and systolic .....	1
Table 2:	Summary of the existing systems .....	15
Table 3:	Pros and cons of XP.....	20
Table 4:	Demographic characteristics of the patients who responded.....	26
Table 5:	Functional requirements of the system .....	32
Table 6:	Non-functional requirements of the system.....	33
Table 7:	Proposed system hardware components and tools.....	44
Table 8:	Comparison of IDE's and programming languages .....	53
Table 9:	Unit testing for the system processes.....	66
Table 10:	Integration testing for the system .....	67
Table 11:	Test cases summary .....	68
Table 12:	Responses from the system's validation.....	70
Table 13:	System validation summary.....	71

## LIST OF FIGURES

Figure 1:	(a) Blood pressure testing at a clinic (b) Self-blood pressure testing at home.....	5
Figure 2:	Best blood HBPM (Hall, 2022) .....	13
Figure 3:	Chronic patients cared for at Rocket Health Clinic (Rocket, 2021).....	17
Figure 4:	Extreme Programming (XP) agile approach (Beck, 2004) .....	20
Figure 5:	Patients' results on tracking records after self-testing of blood pressure.....	25
Figure 6:	Results of patients tracking records of high blood pressure.....	25
Figure 7:	(a) Medical practitioners' results on methods used for blood pressure testing and (b) Patients' results on methods used for blood pressure testing .....	27
Figure 8:	(a)Medical practitioners' results on challenges faced with hospital testing methods of blood pressure and (b) Patients' results on challenges with hospital testing methods of blood pressure .....	28
Figure 9:	(a) Medical practitioners' response to challenges with home-based testing methods of blood pressure and (b) Patients' response to challenges with home-based testing methods of blood pressure .....	29
Figure 10:	Challenges in giving health care to hypertension patients .....	30
Figure 11:	(a)Medical practitioners' response to improvements suggested for the existing blood pressure testing devices/methods and (b) Patients' response to improvements suggested for the existing blood pressure testing devices/methods .....	31
Figure 12:	Context Diagram of the Proposed System .....	36
Figure 13:	The system components and sensors at input, output, and processing sides.....	37
Figure 14:	Main control and sensory section of the system's hardware circuit .....	38
Figure 15:	Display section of the system's hardware circuit .....	38
Figure 16:	The PCB for the Main control and sensory section of the system's hardware .....	39
Figure 17:	The PCB for the Display section of the system's hardware .....	39
Figure 18:	General needs use case diagram for the wristband system .....	41

Figure 19: (a) Flow chart for the hardware section of the wristband system (b) Flow chart for the web application of the wristband system .....	42
Figure 20: Database schema for the system's web application .....	43
Figure 21: The DOIT ESP32 DevKit (Cameron, 2023) .....	45
Figure 22: The MKB0803 sensor (Zhong et al., 2020).....	45
Figure 23: The MAX30102 sensor (Makers, 2023).....	46
Figure 24: The DS18B20 Sensor (Alibaba, 2024).....	46
Figure 25: The OLED display (Lastminuteengineers, 2024).....	47
Figure 26: The V.KEI GPS Module .....	48
Figure 27: The UC15-3G module (Empowerlaptop, 2022).....	49
Figure 28: The SIM800L GSM Module .....	50
Figure 29: Patient view module of the system's web application .....	54
Figure 30: Conceptual diagram of the proposed system.....	57
Figure 31: Login Panel of the wristband's web application.....	58
Figure 32: Dashboard panel for the wristband's web application .....	58
Figure 33: Doctor's module for wristband's web application .....	59
Figure 34: Role module for wristband's web application.....	59
Figure 35: Device module for wristband's web application .....	60
Figure 36: Registered Patient's details module for wristband's web application .....	60
Figure 37: Add new patient's details .....	61
Figure 38: Patient's blood pressure graph .....	61
Figure 39: Tracked Location for the Patient using the wristband device .....	62
Figure 40: Wristband in use by the patient .....	63
Figure 41: The SMS notification from the wristband device .....	63
Figure 42: Testing Phases .....	65

## LIST OF APPENDICES

Appendix 1:	Sample Size Determination.....	81
Appendix 2:	Questionnaire to Medical Practitioners.....	82
Appendix 3:	Questionnaire to Hypertension Patients.....	86
Appendix 4:	Questionnaire for System Validation.....	90
Appendix 5:	Codes for Final Hardware Prototype .....	92
Appendix 6:	Automatic Report Generation .....	106
Appendix 7:	Photo of a Final Prototype .....	107

## LIST OF ABBREVIATIONS AND SYMBOLS

°	Degrees
3G	Third Generation
ABPM	Ambulatory Blood Pressure Monitoring
API	Application Programming Interface
BMI	Body Mass Index
ECG	Electrocardiogram
FDA	Food and Drug Administration
GND	Ground
GPRS	General Packet Radio Service
GPS	Global Positioning System
GSM	Global System for Mobile Communications
HBPM	Home Blood Pressure Monitoring
ICT	Information and Communication Technology
ICU	Intensive Care Unit
IIC	Inter Integrated Circuit
IoT	Internet of Things
ISO	International Organization for Standardization
LED	Light Emitting Diode
MHz	Mega Hertz
OLED	Organic Light Emitting Diode
SDLC	System Development Life Cycle
SIM	Subscriber Identity Module
SMS	Short Message Service

SpO2	Oxygen Saturation
WiFi	Wireless Fidelity
UART	Universal Asynchronous Receiver/Transmitter
IDE	Integrated Development Environment

# CHAPTER ONE

## INTRODUCTION

### 1.1 Background of the Problem

Blood pressure is determined by the amount of blood the heart pumps and the level of resistance to blood flow in the arteries. The unit of measurement for blood pressure is millimeters of mercury (mmHg), with readings usually provided in pairs. The upper (systolic) value is given first, followed by the lower (diastolic) value. According to the new European hypertension guidelines, hypertension is defined as a systolic reading equal to or greater than 140 mmHg and a diastolic reading equal to or greater than 90 mmHg (Ibrahim, 2019). Blood pressure has various stages as shown in Table 1.

**Table 1: Blood pressure stages and ranges of diastolic and systolic**

<b>Blood Pressure Category</b>	<b>Systolic mmHg (Upper Number)</b>		<b>Diastolic mmHg (Lower Number)</b>
Hypotension	Less than 110	and	Less than 70
Normal	110-119	and	70-80
Elevated (Prehypertension)	120-129	and	70-80
Hypertension Stage 1	130-139	or	80-89
Hypertension Stage 2	140 or higher	or	90-120
Hypertensive	Higher than 180	and/or	Higher than 120

#### 1.1.1 Normal Vital Signs

Monitoring vital signs is crucial for assessing a patient's health. The following ranges represent normal vital signs for a resting adult (Vorvirk, 2023):

- (i) Blood pressure: 90/60 mm Hg to 120/80 mm Hg
- (ii) Pulse: 60 to 100 beats per minute
- (iii) Breathing: 12 to 18 breaths per minute
- (iv) Temperature: 97.8° Fahrenheit (F) to 99.1°F or 36.5°Celsius (C) to 37.3°C

### 1.1.2 Essential Body Functions that Reflect Blood Pressure

Monitoring blood pressure involves understanding several key body functions. The following body functions are crucial indicators (Li *et al.*, 2018):

- (i) Heartbeat
- (ii) Breathing rate

### 1.1.3 Causes of Hypertension

Hypertension can be attributed to several factors. Primary hypertension, also known as stage 1 hypertension, is a prevalent form that tends to develop gradually over the years with no specific identifiable cause. Secondary hypertension, or stage 2 hypertension, results from underlying medical conditions such as blood vessel problems, adrenal gland tumors, or kidney disease (mayoclinic, 2024). Several risk factors contribute to hypertension prevalence:

- (i) **Age:** Men over 64 and women over 65 are at higher risk.
- (ii) **Obesity:** Excess weight can induce changes in blood vessels, elevating the risk of hypertension and heart disease.
- (iii) **Stress:** This can lead to temporary spikes in blood pressure.
- (iv) **Race:** Hypertension tends to develop earlier in Black individuals compared to White individuals.
- (v) **Pregnancy:** Conditions like pre-eclampsia can temporarily increase blood pressure and persist after childbirth.

Hypertension affects an estimated 26% of the global population (972 million people), with prevalence anticipated to rise to 29% by 2025, mainly due to increases in economically developing countries (Samson, 2024). Hypertension's high prevalence imposes a significant public health burden globally, with the number of affected individuals increasing from 650 million to 1.28 billion over the last thirty years. Those between the ages of 30 and 79 are most affected, with two-thirds residing in low- and middle-income nations. Over 720 million people with hypertension are not receiving the care they require (World Health Organization, 2023).

In a survey conducted in seven communities in Kenya, Nigeria, Tanzania, and Uganda, a quarter of 3549 participants had high blood pressure, and about 40% were unaware that they had it (Okello *et al.*, 2020). In Uganda, pre-hypertension prevalence was found to be 38.8% among adults aged 18 years and above, while hypertension prevalence was 31.5% (Lunyera, 2018). Hypertension severity in Uganda is associated with advancing age and higher Body Mass Index (BMI) (Mustapha, 2022).

#### **1.1.4 eHealth and Digital Devices in Hypertension Management**

eHealth, which includes the use of ICT in healthcare, has been instrumental in managing chronic diseases like hypertension. Digital health technologies, such as wearable devices, mobile health apps, and telemedicine, offer significant potential for monitoring and controlling blood pressure remotely by providing continuous monitoring, real-time data, and personalized feedback. These interventions can serve as valuable and scalable tools for improving patient self-management, informing new clinical practice guidelines, and enhancing workflows in clinical settings (Cavero-Redondo *et al.*, 2021).

#### **1.1.5 Impact of Hypertension**

Hypertension, particularly stage 1, is estimated to cause 7.5 million deaths annually, accounting for 12.8% of all deaths worldwide (World Health Organization, 2023). The symptoms of high blood pressure include chest discomfort, shortness of breath, back pain, general body weakness, and headaches (Clinic, 2022).

#### **1.1.6 Project Core Concepts**

The following are the core concepts underpinning this enhanced IoT-based wristband project:

- (i) **Internet of Things (IoT):** The wristband will be integrated with IoT technology, enabling it to connect to the Internet and transmit data in real-time. This connectivity allows for continuous monitoring and data collection, which can be accessed by healthcare providers remotely.
- (ii) **Wristband:** The wristband is designed to be worn by patients and will continuously monitor vital signs, particularly blood pressure. It will use sensors to collect data and transmit it to a central database.

- (iii) **Remote Monitoring:** The collected data will be accessible to healthcare providers in real time through a secure online platform. This enables remote monitoring, allowing healthcare professionals to detect early signs of hypertension complications and provide timely interventions.
- (iv) **Home Blood Pressure Monitoring (HBPM):** The wristband will empower patients to monitor their blood pressure at home, reducing the need for frequent hospital visits. This approach aligns with the growing trend of HBPM to improve hypertension management and patient outcomes. The market for HBPM devices was valued at approximately USD 1.25 billion in 2024 and is projected to grow to around USD 2.07 billion by 2029. The adoption of HBPM saw a notable rise during the COVID-19 pandemic (Mordor Intelligence, 2024).

Several devices can continuously monitor blood pressure. The Samsung Galaxy Watch4 can monitor both ECG and blood pressure when the Samsung Health Monitor app is installed (Pranob Mehrotra, 2022). Omron's HeartGuide is also a wristwatch designed to monitor blood pressure fluctuations. Both technologies require users to contact a doctor if readings deviate from acceptable blood pressure levels (Dresden, 2021).

This project aimed to develop an enhanced IoT-based wristband for remote monitoring and early detection of hypertension complications in Uganda. This system aims to address the challenges of real-time communication and record storage in developing countries, facilitating early intervention to mitigate hypertension-related complications.

## 1.2 Statement of the Problem

Approximately only 1 in 5 adults have hypertension under control and reducing its prevalence by 33% by 2030 is one of the global targets for non-communicable diseases (World Health Organization, 2023).

Effective blood pressure monitoring is crucial for hypertension management, yet current methods face significant limitations. Hospital-based diagnosis (as shown in Fig. 1 (a)) and Home Blood Pressure Monitoring (HBPM) as shown in Fig. 1(b) are commonly used, but patients often struggle to access timely medical attention due to the unavailability of doctors, distance to health centers, or misinterpretation of results. Moreover, existing monitoring systems cannot send real-time notifications to healthcare providers and next of kin in critical

situations. This limitation prevents doctors from tracking and identifying trends in patients' blood pressure and hampers immediate first aid response from next of kin.

Additionally, current systems do not support remote tracking of patients' geographical locations, a feature that could be vital for providing timely medical assistance. The inability to integrate real-time alerts, remote tracking, and comprehensive data sharing with healthcare providers represents a significant technical gap in the management of hypertension.



**Figure 1: (a) Blood pressure testing at a clinic (b) Self-blood pressure testing at home**

To address these limitations, this project aims to develop an IoT-based wristband for remote monitoring and early detection of hypertension complications in Uganda. This wristband will provide real-time wireless transmission of vital signs, including blood pressure, heart rate, oxygen saturation, and body temperature. It will send instant SMS alerts to the patient, their doctor, and next of kin upon detecting critical conditions, ensuring timely medical intervention and first aid. Additionally, the system will allow for remote tracking of blood pressure trends and the patient's geographical location, enabling healthcare providers to offer better-informed and timely care.

This enhanced system is designed to overcome the current challenges by integrating real-time communication, comprehensive monitoring, and emergency response capabilities, thus significantly improving the management of hypertension and reducing associated complications in Uganda.

### **1.3 Rationale of the Study**

The prevalence of non-communicable diseases (NCDs) is increasing globally, with the majority of morbidity and mortality occurring in low- and middle-income countries. In Uganda, a study by Siddharthan *et al.* (2021) surveyed 16 694 adults, of whom 10 563 (63%) participated in the self-reported study. The average age of respondents was 37.8 years, with 45% (7481) being male. Hypertension emerged as the most prevalent NCD at 6.3%. Other reported conditions included diabetes (1.1%), asthma (1.1%), COPD (0.7%), and kidney disease (0.4%) (Siddharthan *et al.*, 2021).

Uganda's healthcare infrastructure is inadequate to effectively manage the increasing burden of hypertension. With only 6937 health facilities available to serve a population exceeding 45 million (Uganda Ministry of Health, 2020), patients face long waiting times, overworked medical staff, and significant bureaucratic obstacles. Rural areas are especially underserved, requiring patients to travel considerable distances to access healthcare services.

The limited capacity of healthcare facilities underscores the urgent need for innovative solutions like telemedicine and remote patient monitoring systems. These technologies can reduce the pressure on health centers by offering continuous, real-time monitoring of patients, facilitating early detection of complications, and minimizing the necessity for frequent in-person visits. By enhancing remote monitoring capabilities, this project aims to improve hypertension management, lower mortality rates, and ensure timely medical intervention, thereby addressing a critical gap in Uganda's healthcare system.

### **1.4 Project Objectives**

#### **1.4.1 General Objective**

To develop an enhanced IoT-based wristband for remote monitoring and early detection of hypertension complications in Uganda.

#### **1.4.2 Specific Objectives**

The study aimed to achieve the following specific objectives:

- (i) To identify requirements for the enhanced IoT-based wristband for remote monitoring and early detection of hypertension complications in Uganda.

- (ii) To develop an enhanced IoT-based wristband for remote monitoring and early detection of hypertension complications in Uganda.
- (iii) To validate the enhanced IoT-based wristband for remote monitoring and early detection of hypertension complications in Uganda.

## 1.5 Research Questions

The study intended to answer the following questions:

- (i) What are the requirements for the enhanced IoT-based wristband for remote monitoring and early detection of hypertension complications in Uganda?
- (ii) How to develop the enhanced IoT-based wristband for remote monitoring and early detection of hypertension complications in Uganda?
- (iii) Will the enhanced IoT-based wristband for remote monitoring and early detection of hypertension complications in Uganda meet the users' requirements?

## 1.6 Significance of the Project

This project aims to significantly improve health outcomes among patients with hypertension by promoting the use of IoT in medical care as a preventive measure against complications. The significance of this project can be outlined as follows:

- (i) **Early Detection and Prevention:** By utilizing an IoT-based remote monitoring system, the proposed solution will enable early detection of hypertension-related complications. This timely intervention can significantly reduce the risk of severe health issues such as heart disease, stroke, and kidney failure, thereby improving patient prognosis and quality of life.
- (ii) **Enhanced Healthcare Accessibility:** The project will bridge the gap between patients and healthcare providers, especially in rural and underserved areas where access to medical facilities is limited. Through real-time monitoring and instant notifications via IoT devices, patients will receive timely medical advice without the need to travel long distances, thus overcoming geographical barriers.

- (iii) **Data-Driven Healthcare:** Medical institutions like Rocket Health in Uganda will benefit from systematic data collection on individuals with hypertension through IoT devices. This data can be used for forecasting potential difficulties, conducting further health analysis, and improving patient management strategies. Such data-driven approaches will lead to better-informed healthcare decisions and policies.
- (iv) **Patient Empowerment and Engagement:** The proposed IoT-based system will empower patients by providing them with tools to actively monitor and manage their health conditions. This increased engagement can lead to better adherence to treatment plans, lifestyle modifications, and overall improved health outcomes.
- (v) **Reduction in Healthcare Costs:** By preventing complications and reducing the need for emergency medical interventions, the IoT remote monitoring system can help lower healthcare costs. Early detection and management of hypertension can decrease hospital admissions, reduce the burden on healthcare facilities, and optimize resource utilization.
- (vi) **Advancement in IoT Healthcare Technologies:** The project will contribute to the advancement of IoT in healthcare in Uganda and similar developing countries. The insights and experiences gained from this project will be valuable for future research and development of IoT-based remote monitoring technologies, potentially extending their application to other chronic diseases such as diabetes.

## 1.7 Delineation of the Study

This project focuses on developing an enhanced IoT-based wristband for the remote monitoring and early detection of complications among hypertension patients in Uganda. The project encompasses the following key components and activities:

- (i) **Problem Identification:** The project begins with identifying the critical challenges faced by hypertension patients in Uganda, including limited access to healthcare facilities, delayed medical intervention, and inadequate real-time monitoring.
- (ii) **System Design and Development:** The core of the project involves designing and developing an IoT-enabled wristband integrated with various sensors. These sensors

are capable of continuously monitoring vital signs such as blood pressure, heart rate, oxygen saturation, and body temperature.

- (iii) **Telecommunication and Data Transmission:** The wristband is equipped with telecommunication modules to facilitate wireless transmission of the collected data. This data is sent in real-time to a cloud-based server, ensuring continuous monitoring.
- (iv) **Web Application Development:** A web application is developed for healthcare providers to monitor patients' health status remotely. This application provides a user-friendly interface for doctors to access real-time data, analyze trends, and make informed decisions.
- (v) **Alert System:** The system includes an alert mechanism that triggers SMS notifications to three key parties, the patient, their doctor, and their next of kin—when critical health parameters are detected. This ensures immediate attention and timely medical intervention.
- (vi) **Testing and Data Collection:** The project involves pilot testing the wristband and web application with a sample group of hypertension patients and healthcare providers. Data is collected to evaluate the system's performance, reliability, and user satisfaction.
- (vii) **Evaluation and Validation:** The collected data is analyzed to validate the effectiveness of the IoT-based system in improving health outcomes. This includes assessing the accuracy of the sensors, the responsiveness of the alert system, and the overall usability of the web application.
- (viii) **Stakeholder Involvement:** The project engages various stakeholders, including patients, next of kin, and healthcare providers, to ensure the system meets the needs of all users. Feedback from these stakeholders is used to refine and improve the system.
- (ix) **Documentation and Reporting:** Comprehensive documentation is maintained throughout the project, detailing the design process, development stages, testing procedures, and evaluation results. This documentation serves as a reference for future research and development in IoT-based healthcare solutions.

## CHAPTER TWO

### LITERATURE REVIEW

#### 2.1 Definition of Key Terms

Remote patient monitoring is the use of telecommunication technologies such as software, hardware, and communication protocols to transmit data between the patient and medical doctors to improve healthcare (Chauhan, 2023).

Data are acquired with the capability of various embedded sensors to transmit wirelessly based on wireless body networks (WBAN), body area networks (BAN), or personal area networks (PAN) (Malasinghe *et al.*, 2019).

Chronic refers to the prolonged situation or habit within individuals. It is typically used in the context of health conditions that persist in people most often for their entire life. This is according to the Merriam-Webster dictionary.

Hypertension, also known as high blood pressure, is a medical condition characterized by elevation of blood pressure in arteries. According to the American Heart Association Guidelines, the threshold of 130/80 mmHg was lowered from 140/90 mmHg and is an indicator of hypertension stage 1 (Garovic *et al.*, 2021).

Hypotension refers to abnormally low blood pressure according to the Merriam-Webster dictionary. is indicated by a threshold lower than 110/70 mmHg (Garovic *et al.*, 2021). This may lead to inadequate blood flow to the body's organs and tissues.

#### 2.2 Related Works

Monitoring blood pressure has been the subject of several previous studies in the medical field. There are consequently many diverse strategies in use.

Non-invasive methods have also been explored in measuring blood pressure. The tonometry technique was reviewed and found to solve beat-to-beat and continuous measurement. However, this is limited to the need for continuous control of the tonometer positioning hence subjects are required to be in a supine position during monitoring. Apart from frequent calibration needs, this leads to inaccuracy and comfort decrease (Chung, 2013). The oscillometric technique was another technique investigated to use non-invasive methods to

automatically measure blood pressure. However, the oscillometric technology used is noisy, painful, and uncomfortable for long-term monitoring (Alpert, 2014).

The innovation of hypertension mobile applications has increased patient engagement through features like automatic or manual blood pressure logging. These apps help patients track their blood pressure trends and provide reminders for medication and lifestyle changes. However, they are often inadequately regulated and do not share data with doctors directly. This limitation could lead to patients self-medicating unnecessarily (Kumar, 2015).

Home Blood Pressure Monitoring (HBPM) is a mechanism of self-testing and monitoring that was incorporated into hypertension patients' care and was recommended by major clinic regulators because of the significant benefit of enabling patients to take an active role in their hypertension status management as often as they wish (Liyanage-Don *et al.*, 2019). However, they have a limitation of inaccuracy if the patient is not in a relaxed state.

The wireless upper arm cuffs that use sphygmomanometer sensors for blood pressure self-measurement are also a type of HBPM and come with the benefit of sending data to computers or mobile phones using Bluetooth communication. However, in addition to Bluetooth's limited data transfer range, users of this technology must always remember to complete their mobile phones' Bluetooth configurations (Trust, 2016).

To empower patients with hypertension through BPM, IoT, and remote sensing, an architecture that joins health devices and environmental sensors, together with an information system, was developed (Daniel *et al.*, 2017). However, it uses Bluetooth Low Energy for communication between the medical devices and the core system, which requires configurations by the user. This can be a limitation because patients may sometimes forget to configure their devices, leading to potential lapses in monitoring.

Noah (2018) discussed the impacts of enhancing remote patient monitoring such as wearable activity trackers and found that this improved health outcomes for patients with chronic diseases such as heart disease, high blood pressure, and Parkinson's disease. This study also identifies that older people over 55 years appreciate innovation more (Noah *et al.*, 2018).

Nestor designed the eHeart-BP Prototype to monitor blood pressure using IoT technology. This system utilized a physical arterial blood pressure monitor with an integrated ESP8266 WiFi module to send data to a web server. Machine learning algorithms were incorporated to support

relevant health decisions and report biometric measurements in real time to healthcare experts. However, the system's reliance on the ESP8266 WiFi module for data transmission limited its effectiveness due to potential connectivity issues and limited range (Pulgarín *et al.*, 2019).

The intra-arterial method was used in radial artery cannulation which is a common procedure in ICUs. Although the method improved accuracy and precision, it was discovered to be linked to bleeding, infection risk, and nerve damage in patients (Imbriaco, 2020).

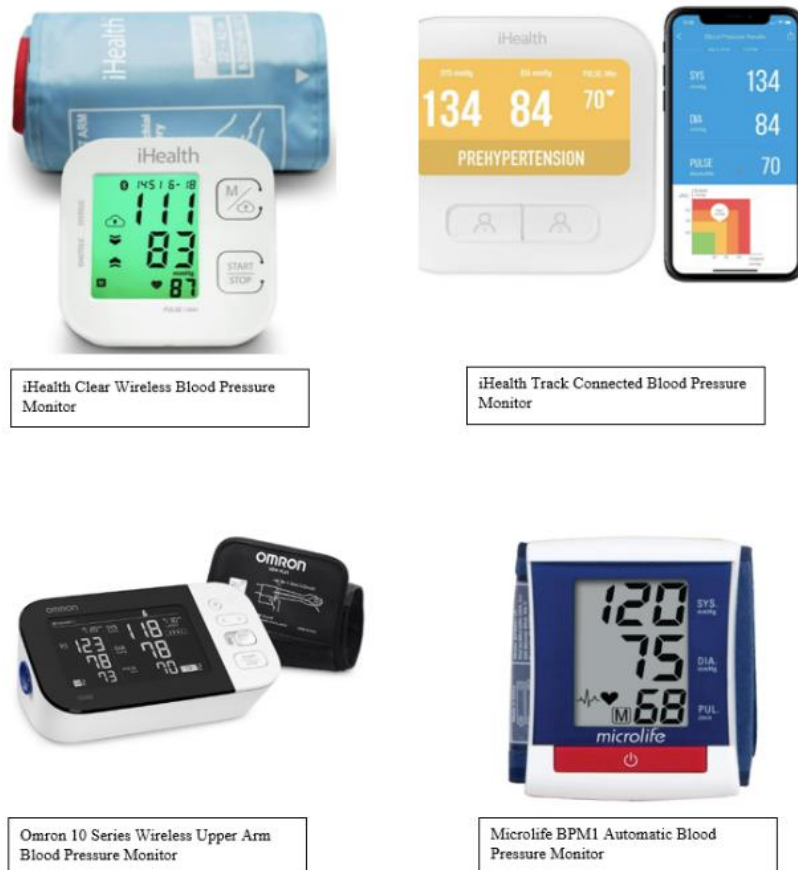
An integrated system for chronic hypertension patients was developed and implemented. This system involves an automatized follow-up and alerts users about their disease status via voice. Although the proposed system was easy to use and efficient, the voice call alerts were only scheduled for mornings and afternoons strictly. To this end, the pressure values recorded are sent to the monitoring system through the user's smartphone and require success verification. The limitation of this system was that if the user is already in a critical condition that doesn't allow him or her to verify the transmission of the pressure reading, the next procedure of the system calling the registered relatives and alerting the health professionals will be automatically halted (Urrea *et al.*, 2020).

The inflatable arm cuff around the arm using a pressure-measuring gauge is one of the common diagnosis practices of hypertension at a physical hospital (Clinic, 2021). However, large clinic bills, long queues, and bureaucracy are scary challenges for hypertension patients when using this technology.

Ambulatory BP Monitoring (ABPM) is a confirmatory monitoring test carried out by a doctor at a hospital to diagnose and check for underlying conditions that could lead to high blood pressure. This is done at regular intervals for 24 hours to provide an appropriate picture of the patient's blood pressure fluctuations (Clinic, 2021). The limitation of the ABPM devices is that not all medical centers can afford them because they are very expensive, therefore they are not long-term solutions.

According to Hall (2022), the current trend of blood pressure monitors (Fig. 2) includes FORA P30 Plus Arm Blood Pressure Monitor, iHealth Track Connected Blood Pressure Monitor, Omron 10 Series Wireless Upper Arm Blood Pressure Monitor, iHealth Clear Wireless Blood Pressure Monitor, iHealth Ease Wireless Monitor, A & D Premium Wireless Blood Pressure Monitor, and the Microlife BPM1 Automatic Blood Pressure Monitor among others. The Omron 10 series Wireless Upper Arm BPM is one of the world's leading blood pressure

monitors and has the ability to send hypertension alerts via Bluetooth technology (Hall, 2022). However, this requires regular configurations by the patient and cannot send the normal SMS to the doctor in case of a critical hypertension condition (Dresden, 2021).



**Figure 2: Best blood HBPM (Hall, 2022)**

Priya *et al.* (2023) designed a Smart IoT Solution for Personalized Health. It was based on an MQTT-based system for blood pressure monitoring. Although it enhanced healthcare awareness through IoT technology and the MQTT protocol, the system's effectiveness is limited by its reliance on a stable internet connection for real-time communication, which may be problematic in areas with poor connectivity (Priya *et al.*, 2023).

Gusti *et al.* (2023) developed an IoT-based blood pressure monitoring device that facilitates digital blood pressure measurement and data transmission to widely accessible applications and websites. The device uses an MPX5050GP pressure sensor, Arduino Nano, and NodeMCU ESP32, along with other components programmed using the Arduino IDE. Data transmission via a Wi-Fi network is responsible for sending the data to Google Spreadsheet and Telegram for further documentation and analysis. However, the system's reliance on a stable Wi-Fi

connection for data transmission can be problematic in areas with poor or unreliable connectivity, limiting its effectiveness (Gusti *et al.*, 2023).

The innovation of hypertension mobile applications has increased patient engagement through automatic or manual blood pressure logging. However, these applications are often inadequately regulated and do not share data directly with doctors, potentially leading to unnecessary self-medication. While some mobile health (mHealth) applications can monitor blood pressure and other vital signs, they generally lack real-time alert features to notify doctors or next of kin instantly when readings deviate from normal ranges. This lack of instant alerts is a significant limitation, as timely interventions are crucial in managing hypertension effectively. The development of IoT-based systems that provide instant SMS alerts to healthcare providers and next of kin can bridge this gap, ensuring immediate attention when necessary (Fujiwara *et al.*, 2024).

### **2.3 Technical Gap**

Based on the analysis of the various recent related works from different research databases and journals as shown in Table 2, several limitations in existing solutions have been identified. Current systems, such as the eHeart-BP Prototype by Bolívar Pulgarín *et al.* (2019) and the IoT-Based Blood Pressure Monitoring Device by Gusti *et al.* (2023), rely heavily on Wi-Fi for data transmission. This dependency can limit their effectiveness in areas with poor connectivity. Moreover, while some solutions, like the Smart IoT Solution for Personalized Health by Priya *et al.* (2023), enhance healthcare awareness through real-time monitoring, they cannot send instant SMS alerts to the patient, doctor, and next of kin in critical situations.

Additionally, these systems do not integrate comprehensive monitoring of multiple vital signs (such as blood pressure, heart rate, oxygen saturation, and body temperature) into a single device. The absence of remote tracking of patients' geographical locations further hampers the ability to provide timely medical assistance. Lastly, there is a significant gap in the capability of existing systems to support remote tracking of blood pressure trends and comprehensive data sharing with healthcare providers through dedicated medical admin applications.

To address these limitations, this project aimed to develop an IoT-based wristband for remote monitoring and early detection of hypertension complications in Uganda. The proposed system will provide real-time wireless transmission of vital signs and send instant SMS alerts to the patient, their doctor, and next of kin upon detecting critical conditions. Additionally, it will

enable remote tracking of blood pressure trends and the patient's geographical location, ensuring timely medical intervention and better-informed care. This enhanced system is designed to overcome current challenges by integrating real-time communication, comprehensive monitoring, and emergency response capabilities, thus significantly improving the management of hypertension and reducing associated complications in Uganda.

**Table 2: Summary of the existing systems**

Reference	Problem Addressed	Proposed Solution	Limitations of the study
Chung (2013)	Solved beat-to-beat and continuous measurement.	Measuring continuous blood pressure by use of the tonometry technique.	A need for continuous control of the tonometer positioning hence subjects are required to be in a supine position during monitoring.
Alpert (2014)	Manual measurement of blood pressure.	Oscillometric blood pressure measuring technique based on non-invasive methods.	The technology used is noisy, painful, and uncomfortable for long-term blood pressure monitoring
Kumar (2015).	Increased patient engagement through blood pressure logging automatically or manually.	Smartphone-based applications for hypertension management	They are inadequately regulated and do not share data with doctors directly.
Trust (2016)	sending data to computers or mobile phones using Bluetooth communication.	wireless upper arm cuffs that use sphygmomanometer sensors for blood pressure self-measurement	Bluetooth's limited data transfer range, users of this technology must always remember to complete their mobile phones' Bluetooth configurations
Daniel <i>et al.</i> (2017)	communication between the medical devices and the core system	Empowerment of Patients with Hypertension through BPM, IoT, and Remote Sensing	patients may sometimes forget to configure Bluetooth connectivity with their devices, leading to potential lapses in monitoring.
Liyanage-Don <i>et al.</i> (2019).	Addressed self-testing mechanisms and enabled patients to have an active role in their hypertension management.	Home Blood Pressure Monitoring	The mechanism was inaccurate if the patient was not in a relaxed state.
Pulgarín <i>et al.</i> (2019).	Incorporated machine learning to support relevant health decisions and report biometric measurements in real-time to healthcare experts.	eHeart-BP Prototype to monitor blood pressure using IoT technology	the system's reliance on the ESP8266 WiFi module for data transmission limited its effectiveness due to potential connectivity issues and limited range

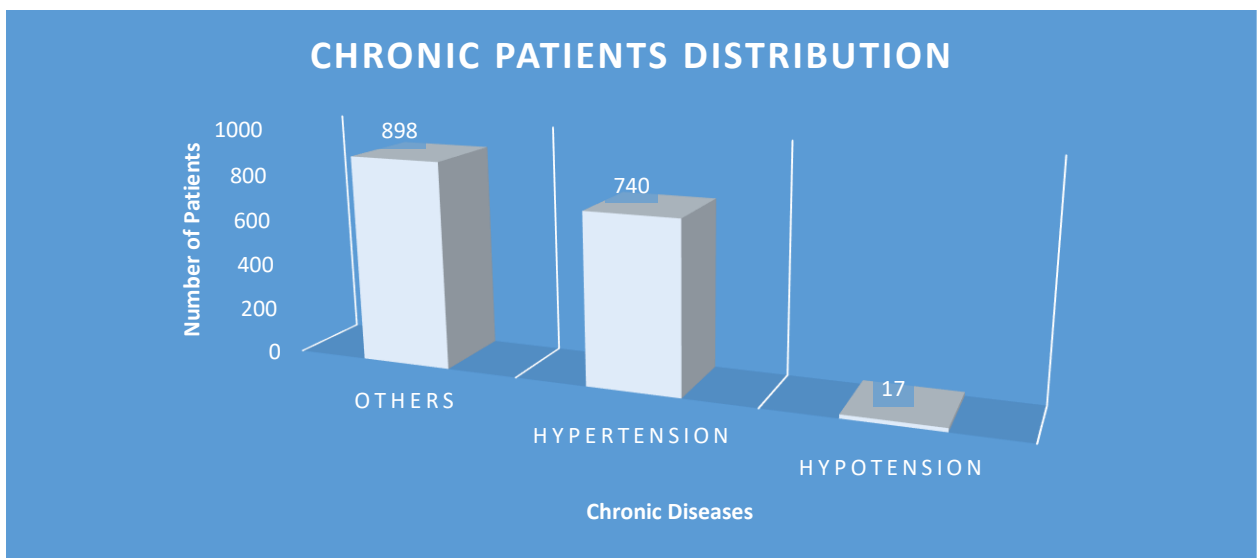
<b>Reference</b>	<b>Problem Addressed</b>	<b>Proposed Solution</b>	<b>Limitations of the study</b>
Urrea <i>et al.</i> (2020)	Provided automatic follow-up and alerts to users about their disease status via voice.	An integrated system for chronic hypertension patients was developed and implemented.	The voice call alerts were only scheduled for mornings and afternoons strictly.
Imbriaco (2020).	The method improved accuracy and precision.	Radial artery cannulation in intensive care unit patients.	The intra-arterial method used was discovered to be linked to bleeding, infection risk, and nerve damage in patients.
Clinic (2021)	Providing confirmatory monitoring tests about the patient's blood pressure to diagnose and check for underlying conditions that could lead to high blood pressure.	Ambulatory Blood Pressure Monitoring	The limitation of the ABPM devices is that not all medical centers can afford them because they are very expensive.
Hall (2022)	Sending hypertension alerts via Bluetooth technology.	Omron 10 Series Wireless Upper Arm BPM	Bluetooth has a limited data transfer range and users of this technology must always remember to complete Bluetooth's configurations.
Priya <i>et al.</i> (2023).	enhanced healthcare awareness through IoT technology and the MQTT protocol	Smart IoT Solutions for Personalized Health: MQTT- Based Blood Pressure Monitoring System	the system's effectiveness is limited by its reliance on a stable internet connection for real-time communication, which may be problematic in areas with poor connectivity
Gusti <i>et al.</i> (2023)	facilitated digital blood pressure measurement and data transmission to widely accessible applications and websites	Real-time monitoring system for blood pressure monitoring based on the Internet of Things	the system's reliance on a stable Wi-Fi connection for data transmission can be problematic in areas with poor or unreliable connectivity, limiting its effectiveness

## CHAPTER THREE

### MATERIALS AND METHODS

#### 3.1 Project Case Study

The project was carried out at Rocket Health Clinic, located in Kampala, Uganda. Rocket Health is a customer-facing brand launched in 2019 by The Medical Concierge Group (TMCG). Operating under a direct-to-consumer model, Rocket Health aims to bring affordable, quality healthcare closer to the masses within and outside Uganda. The organization operates a 24-hour call center, laboratories, pharmacies, and clinics, all providing access to fully qualified medical practitioners. With over 1655 patients in chronic care, up to 44.71% (740 patients) were diagnosed with hypertension, as shown in Fig. 3. The project aimed to develop an enhanced IoT-based wristband for remote monitoring and early detection of hypertension complications in Uganda. The significant number of hypertension patients receiving chronic care at Rocket Health highlights the demand for continuous monitoring and early detection of complications.



**Figure 3: Chronic patients cared for at Rocket Health Clinic (Rocket, 2021)**

#### 3.2 Research Design

This project used a mixed-methods research design, combining qualitative and quantitative approaches to gain a comprehensive understanding of the current system and assess the needs for the proposed IoT-based wristband system.

### **3.3 Target Population**

This project's targeted population consists of 740 hypertension patients receiving chronic care from Rocket Health in Uganda.

### **3.4 Sampling Techniques and Sample Size**

#### **3.4.1 Sampling Techniques**

- (i) **Snowball Sampling:** This technique was used to identify medical practitioners knowledgeable about the current system. Initial participants referred other practitioners who could provide valuable insights, ensuring a robust collection of qualitative data.
- (ii) **Stratified Sampling:** Used for gathering quantitative data through survey questionnaires. The population was divided into subgroups based on relevant characteristics such as age, gender, or severity of hypertension. Random sampling was then applied within each stratum to ensure proportional representation.

#### **3.4.2 Sample Size**

The sample size for this study was determined using Kish and Leslie's sample size calculation formula (Wiegand, 1968) as detailed in Appendix 1. The calculation considered parameters such as age group, gender, education level, marital status, health status, and employment status of the participants.

Initially, Kish and Leslie's formula yielded a calculated sample size of 253 hypertension patients and 27 medical practitioners from Rocket Health Clinic. However, during the course of the project, logistical challenges and practical constraints necessitated adjustments. Ultimately, the final sample size included 243 hypertension patients and 17 medical practitioners who were successfully engaged and participated in the project.

### **3.5 Data Collection and Analysis**

The following data collection methods and tools were employed to establish functional and non-functional requirements.

### **3.5.1 Data Collection Methods**

#### **(i) Primary Data Collection**

##### *Survey questionnaires*

Administered using Google Forms to collect data from medical professionals and patients. Google Forms was chosen for its accessibility, ease of use, and cost-effectiveness.

##### *Focus group discussions and observations*

Conducted with medical experts and observations of the present systems and Electronic Medical Records (EMR) used at Rocket Health.

#### **(ii) Secondary Data Collection**

Involved gathering information from reports, journals, books, dissertations, databases, and websites related to existing blood pressure monitoring and diagnosis systems.

### **3.5.2 Data Analysis**

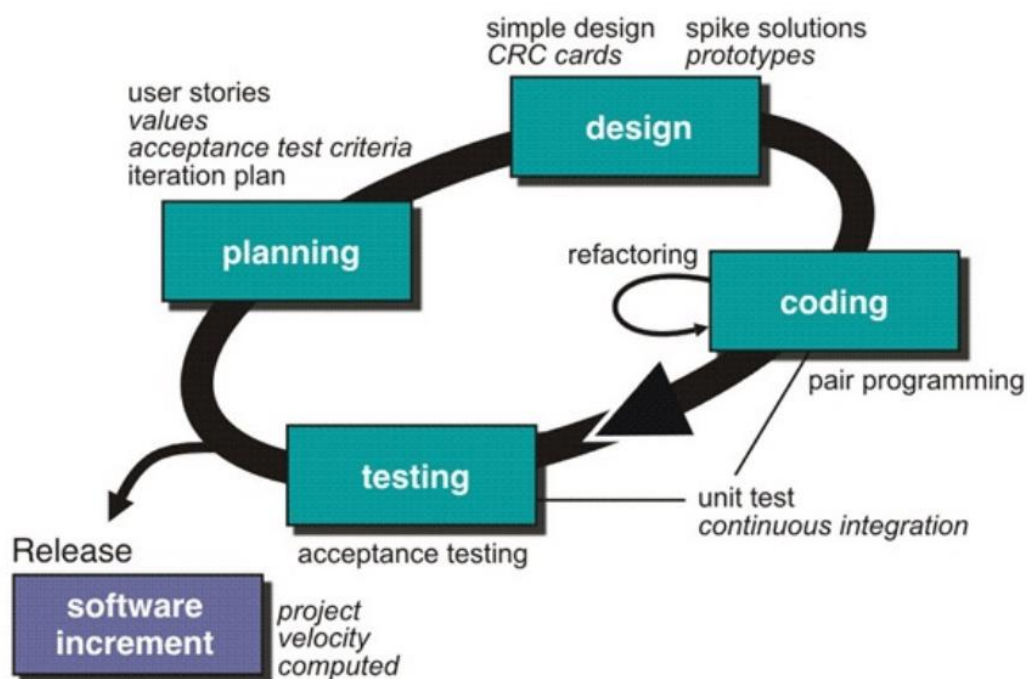
Collected data was cleaned, aggregated, analyzed, and visualized using Power BI. This tool allowed efficient and clear analysis, providing summaries of various aspects of the responses, including trends in blood pressure testing methods and insights into both the proposed and existing systems.

### **3.6 System Development Approach**

The Extreme Programming (XP) agile approach as shown in Fig. 4 was employed for the system development. XP was chosen due to its flexibility in accommodating changes in project requirements and its ability to minimize project risks, especially given the tight deadlines and budget constraints (Beck, 2004). Nevertheless, XP has its pros and cons as shown in Table 3.

**Table 3: Pros and cons of XP**

Advantages	Disadvantages
No unnecessary programming of work	Additional work
Stable software through continuous pair programming	The customer must participate in the process
No overtime, teams work at their own pace	Relatively large time investment
Changes can be made at short notice	Relatively high costs
Close contact with customer	Requires version management
Code is always clear and comprehensible	Requires self-discipline to participate



**Figure 4: Extreme Programming (XP) agile approach (Beck, 2004)**

### 3.6.1 Justification of the Selected Methodology

The selected mixed-methods research methodology is justified for this project because it allows for a thorough exploration of both qualitative and quantitative aspects of the healthcare system for hypertension patients at Rocket Health. The use of snowball sampling is appropriate for identifying knowledgeable medical practitioners, while stratified sampling ensures a representative sample of hypertension patients. The combination of surveys, focus group discussions, and observations provides a holistic understanding of the current system and the

requirements for the new IoT-based wristband. Furthermore, the XP agile approach for system development is well-suited to the project's need for flexibility and quick adaptation to changing requirements, ensuring the delivery of a functional and effective remote monitoring solution for hypertension patients in Uganda.

### **3.7 Ethical Consideration**

To carry out a successful project in line with the health sector, some ethics, regulations, and standards were considered in this study as highlighted in the following subsections.

#### **3.7.1 Ethics**

According to the Research Ethics Committee (2022) below are the National Guidelines for Research Involving Humans as Research Participants.

- (i) Autonomy and respect for participants with diminished autonomy
- (ii) Beneficence which requires justification of expected benefits from the scientific research.
- (iii) Non-maleficence which requires no to do any deliberate harm to participants.
- (iv) Justice requires researchers to treat and distribute care to participants equally.

#### **3.7.2 Regulations and Standards of Medical Devices**

Through Uganda's Ministry of Health (MoH), the Uganda Advisory Committee on Medical Equipment (NACME) was chosen to prepare a medical equipment acquisition and management policy (Ssenkooba *et al.*, 2017). Uganda's National Drug Authority (NDA) controls the import, production, export, and supply of medical devices to protect public health (National Drug Authority, 2024).

Medical devices are regulated under a ministerial decree ADM.140/323/01 of 20<sup>th</sup> July 2020 and statutory Instrument no 77 of the Surgical Instruments and Appliances Regulation 2019 (National Drug Authority, 2024).

Uganda National Bureau of Standards is the body responsible for the certification of standards for all products in Uganda. It adopts such standards from the International Organization for Standardization (ISO) (ISO, 2024).

In conclusion, the developed wristband system is undergoing the procedures as set by the above-mentioned regulatory bodies to meet the health standards required to be used by hypertension patients.

### **3.8 Chapter Summary**

This chapter has detailed the materials and methods used to achieve the project's primary objective: developing an enhanced IoT-based wristband for remote monitoring and early detection of hypertension complications in Uganda. The next chapter will present the results and discussion of this project, including the questionnaire findings, identified system requirements, system design, development, testing, and validation.

## **CHAPTER FOUR**

### **RESULTS AND DISCUSSION**

#### **4.1 Results**

The results and discussion chapter presents the findings of this project on the development of the enhanced IoT-based wristband for remote monitoring and early detection of hypertension complications in Uganda facing hypertension patients in Rocket Health, Uganda. In this chapter, an in-depth analysis of the data collected from a sample of 243 hypertensive patients and 17 medical practitioners is discussed. The participants were used as a sample size to collect data for testing and validation to ensure that the requirements of the system were met.

This study aimed to investigate the effectiveness of the enhanced IoT-based wristband for remote monitoring and early detection of hypertension complications in Uganda and explore the perspectives of medical practitioners on the use of this technology in healthcare. Data were collected through literature review, surveys, group discussions, and observations, and used thematic analysis to analyze the data.

This chapter begins by presenting a summary of the key findings from both the patient and medical practitioner perspectives. A detailed analysis of these findings is then discussed, including their implications and relevance to our research questions. The limitations or caveats associated with this study and suggestions for future research are also presented in this chapter.

Overall, this chapter will provide valuable insights into the effectiveness of the enhanced IoT-based wristband for remote monitoring and early detection of hypertension complications in Uganda and the perspectives of medical practitioners on the use of this technology in healthcare. The findings will contribute to the growing body of knowledge on remote monitoring technologies for healthcare and inform the development of interventions aimed at improving hypertension management.

#### **4.2 Results from Questionnaire**

##### **4.2.1 Results of Analysis of the Existing Solutions**

The literature review revealed that current solutions for remote monitoring of chronic hypertension patients have several limitations. They cannot send instant SMS alerts to both the

patient's doctor and next of kin if critical conditions are detected. Additionally, they do not allow for the remote tracking of blood pressure trends or the transmission of this information to the doctor's dedicated medical admin application. Moreover, these solutions do not track the patient's geographical location, preventing healthcare providers from identifying where a critical patient is located. For instance, a recent study by Urrea *et al.* (2020) found that integrated systems for chronic hypertension patients could not alert registered relatives and health professionals if the user is already in a critical condition due to the inability to verify the transmission of the pressure reading first (Urrea *et al.*, 2020). Similarly, while hypertension mobile applications have increased patient engagement through automatic or manual blood pressure logging, they do not directly share data with doctors (Kumar, 2015). Ambulatory Blood Pressure Monitoring (ABPM) has improved the efficiency of diagnosing and identifying underlying conditions that could cause high blood pressure, providing a more accurate picture of a patient's blood pressure fluctuations (Clinic, 2021). However, ABPM devices are very expensive, making them unaffordable for many medical centers and not a viable long-term solution.

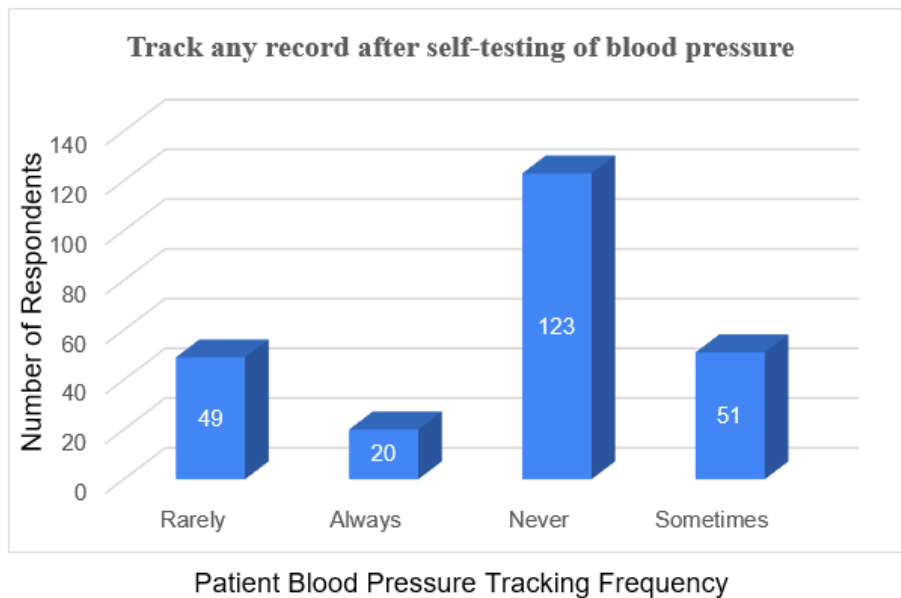
The enhanced IoT-based wristband for remote monitoring and early detection of hypertension complications in Uganda is proposed to address the limitations of existing solutions. This solution enables not only patients but also their next of kin and doctors to receive instant SMS alerts if critical conditions are detected. The system remotely tracks trends in changes in blood pressure for patients using records from the monitoring device and sends this information to the doctor's dedicated medical admin application. Additionally, the solution tracks the patient's geographical location in real-time, enabling the next of kin to quickly identify the patient's location in the event of an emergency.

Overall, the proposed solution has the potential to improve the quality of care provided to chronic hypertension patients in Uganda, by providing timely and accurate monitoring of blood pressure and other vital signs.

#### **4.2.2 Results on Tracking Records After Use of Self-Testing by Patients**

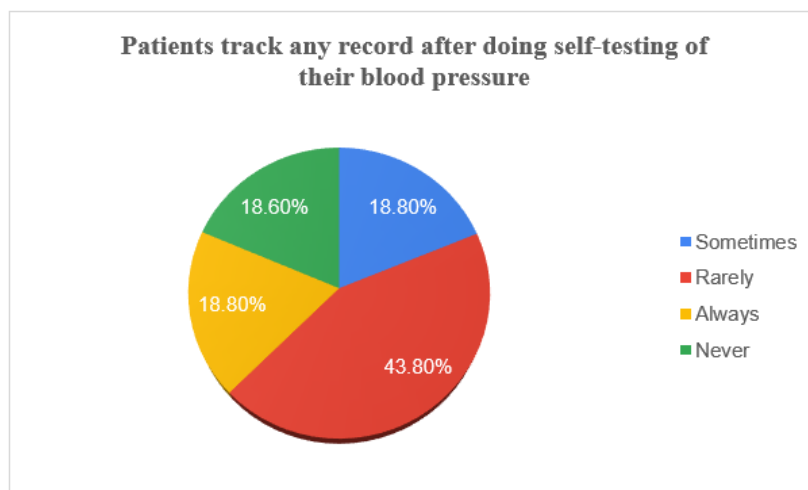
The patient's survey results indicate that out of the 243 respondents, a significant portion do not engage in record-keeping after self-testing their blood pressure. Specifically, 123 respondents (49.38%) do not track their records at all, while 49 respondents (29.16%) rarely track their records. Only 20 respondents (8.23%) consistently track their records, and 51

respondents (20.99%) track their records occasionally. This suggests that there is a notable lack of regular monitoring and documentation among patients. Regular tracking of blood pressure records is crucial for effective disease management and early detection of any abnormalities. Hence, there may be a need for increased awareness and support to encourage consistent record-keeping practices among patients.



**Figure 5: Patients’ results on tracking records after self-testing of blood pressure**

The medical practitioners were asked, “Do patients track any records after doing self-testing of their blood pressure?” The results shown in Fig. 6 indicate that 43.8% of medical practitioners showed that patients never bother to track any records of their implications from blood pressure.



**Figure 6: Results of patients tracking records of high blood pressure**

### 4.2.3 Demographic Information of Respondents

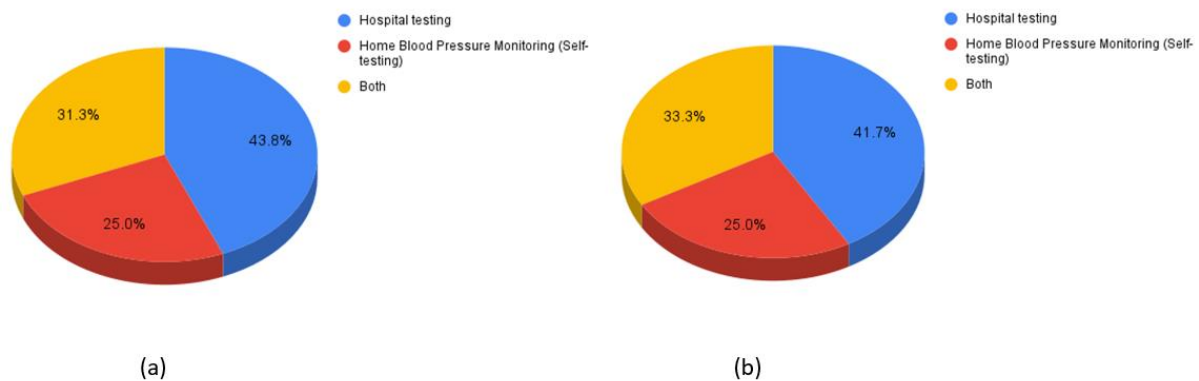
The demographic data collected from 243 patients who participated in the survey provides insight into the patient population's characteristics, as shown in Table 4. The majority of respondents (33.3%) were aged 70 to 79 years, with 81 individuals in this age group. This was followed by those aged 60 to 69 years, representing 20.4% of the respondents (50 individuals). Among the respondents, 108 individuals (44.4%) were married, making it the largest marital status group. This was followed by widowed individuals, who accounted for 16.7% (41 individuals) of the sample, while the smallest group was those who were separated, comprising 11.1% (27 individuals). In terms of gender distribution, 61.1% of the respondents (148 individuals) were female, while 38.9% (95 individuals) were male. This comprehensive overview highlights the key demographic characteristics of the surveyed patient population.

**Table 4: Demographic characteristics of the patients who responded**

<b>Demographic Characteristics</b>	<b>Respondents</b>	<b>Percentage (%)</b>
<b>Gender</b>		
Male	95	38.9
Female	148	61.1
<b>Age group</b>		
Below 18 years old	18	7.4
18-25 years old	14	5.6
26-39 years old	13	5.5
40-49 years old	22	9.3
50-59 years old	32	13.0
60-69 years old	50	20.4
70-79 years old	81	33.3
80 and above	13	5.5
<b>Marital Status</b>		
Married	108	44.4
Divorced	32	13.0
Single, never married	36	14.8
Widowed	40	16.7
Separated	27	11.1

#### 4.2.4 Results of Methods Used for Blood Pressure Testing

According to a survey conducted by among medical practitioners at Rocket Health in Uganda, hypertensive patients are offered various blood pressure testing methods. The results indicate that 43.8% of patients were offered hospital-based testing methods, 25% were offered home blood pressure testing methods by medical practitioners, and 31.3% were offered both methods as depicted in Fig. 7 (a). Similarly, results among hypertension patients showed that 41.7% of patients used hospital testing methods, 25% used home testing methods, and 33.3% used a combination of both methods as illustrated in Fig. 7 (b). These results suggest that both hospital-based and home blood pressure testing methods are commonly used among hypertensive patients in Uganda, with a significant proportion of patients being offered both methods.



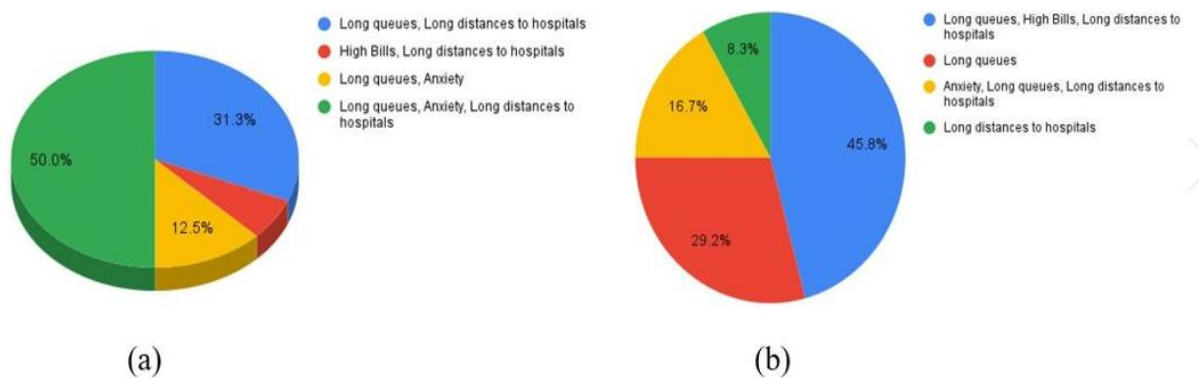
**Figure 7: (a) Medical practitioners' results on methods used for blood pressure testing and (b) Patients' results on methods used for blood pressure testing**

Results on Challenges of Hospital-Testing Methods Based on the results of the survey conducted among medical practitioners as shown in Fig. 8 (a) and patients as shown in Fig. 8 (b), long queues, anxiety, and long distances to hospitals are significant barriers to hospital testing methods for hypertension patients in Uganda. These factors accounted for 50% of the responses from medical practitioners and 45.8% of the responses from patients. Additionally, long queues were a significant issue reported by both medical practitioners (31.1%) and patients (29.2%).

The results also revealed that a small percentage of medical practitioners (6.2%) and patients (8.3%) reported high bills as a barrier to hospital testing, highlighting the importance of affordability in healthcare.

Considering these challenges, IoT-based wristbands for remote monitoring and early detection could be a promising solution to improve hypertension patient outcomes in Uganda. By providing a convenient and cost-effective alternative to hospital testing, these wristbands could help to overcome the barriers of long queues, anxiety, and long distances to hospitals. The results underscore the need for innovative solutions to address the challenges faced by hypertension patients in Uganda, and the potential of remote monitoring and early detection wristbands to improve healthcare outcomes for these patients.

The overall results entail that improving patient access to healthcare facilities and addressing affordability in healthcare is crucial to overcoming the challenges faced by hypertension patients in Uganda.



**Figure 8: (a) Medical practitioners' results on challenges faced with hospital testing methods of blood pressure and (b) Patients' results on challenges with hospital testing methods of blood pressure**

#### 4.2.5 Results of Self-Testing Methods

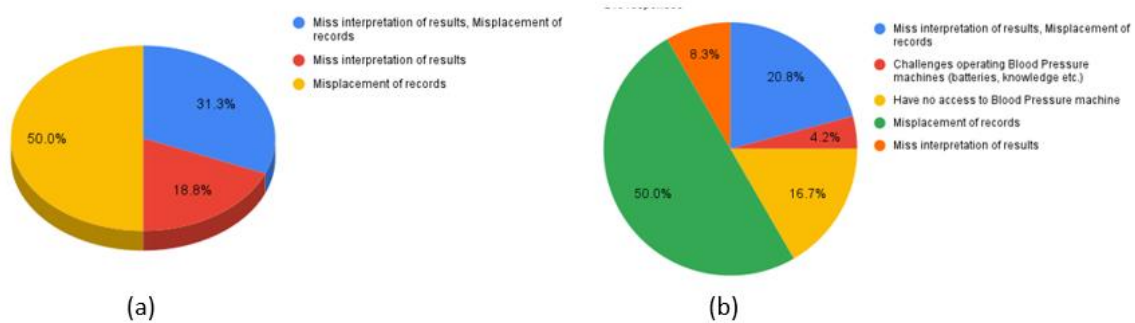
The results of both medical practitioners and patients show that they face challenges related to self-testing methods for blood pressure as shown in Fig. 9. Among the medical practitioners, the biggest challenge identified was the misplacement of blood pressure results, which accounted for 50% of the responses.

Additionally, misinterpretation of blood pressure results was also cited as a significant issue (31.3%). This highlights the importance of proper training for patients on how to accurately interpret blood pressure readings.

Among the patient respondents, misplacement of blood pressure testing records was the most reported challenge (50%). Additionally, 16.7% of patients reported not having access to a blood

pressure machine, indicating a need for increased availability and accessibility of these devices. It is worth noting that some patients also reported challenges operating blood pressure machines (4.2%) and misinterpreting results (8.3%).

The overall results show that both medical practitioners and patients highlighted the misplacement of blood pressure records as the biggest challenge with the home-based (self-testing) method for blood pressure. Hence this suggests the need for an innovative system for storing and accessing patient data in a home-based (self-testing) setting.



**Figure 9: (a) Medical practitioners' response to challenges with home-based testing methods of blood pressure and (b) Patients' response to challenges with home-based testing methods of blood pressure**

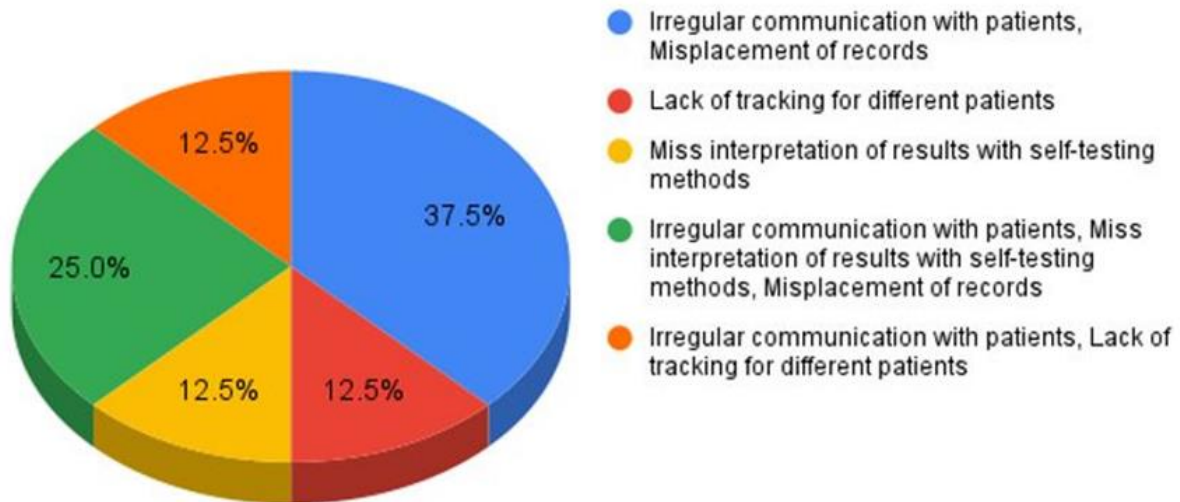
#### 4.2.6 Results on Challenges in Providing Health Care to Hypertension Patients

The results from respondents (medical practitioners) revealed that there are several challenges that they face when providing healthcare to blood pressure patients, as shown in Fig. 10. Irregular communication with patients and misplacement of blood pressure testing records (37.5%) were the most reported challenges. This indicates the need for better communication systems and record-keeping practices to improve patient outcomes.

The lack of remote tracking of the health progress of different hypertension patients was also reported as a challenge by 12.5% of respondents. Similarly, 12.5% of respondents reported misinterpretation of results with self-testing as a challenge, indicating the need for proper patient education on how to accurately interpret blood pressure readings.

Interestingly, 25% of respondents reported irregular communication with patients, misplacement of records, and misinterpretation of results as challenges. This highlights the need for a comprehensive and integrated system that can address multiple challenges simultaneously.

Overall, an enhanced IoT-based wristband for remote monitoring and early detection of hypertension complications in Uganda could be an innovative solution in addressing the aforementioned challenges simultaneously.



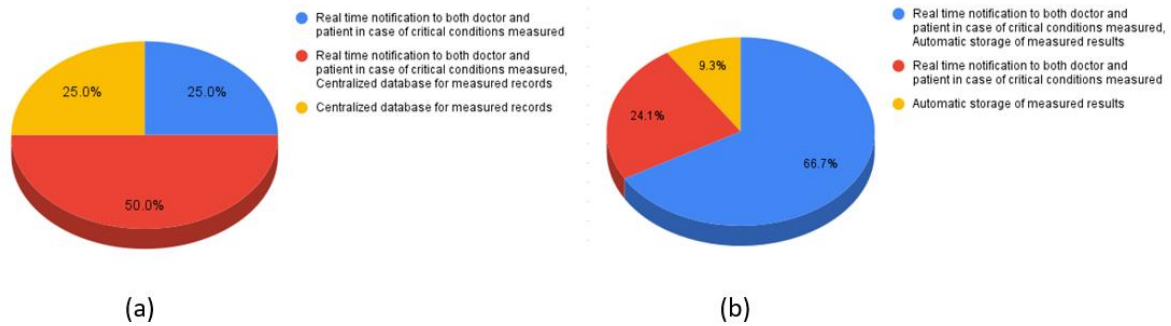
**Figure 10: Challenges in giving health care to hypertension patients**

#### 4.2.7 Results of Improvements on the Existing Solutions

According to the results obtained from the questionnaire survey, both medical practitioners and patients suggested improvements for the existing blood pressure measuring devices/methods as shown in Fig. 11. Medical practitioners of Rocket Health Clinic recommended that real-time notifications to both the doctor and the patient in case of critical conditions measured and a centralized database for measured records would improve the existing blood pressure measuring devices/methods. This recommendation accounted for 50.0% of the responses. Additionally, 25.0% of the medical practitioners recommended real-time notifications to both the doctor and the patient in case of critical conditions measured, while 25.0% recommended a centralized database for measured records.

On the other hand, patients recommended that real-time notifications to both the doctor and the patient in case of critical conditions measured and automatic storage of measured records would improve the existing blood pressure measuring devices/methods. This recommendation accounted for 66.7% of the responses. Furthermore, 24.1% of the patients recommended real-time notifications to both the doctor and the patient in case of critical conditions measured, while 9.3% recommended automatic storage of measured records.

Overall results for both medical practitioners and patients revealed that real-time notifications to both the doctor and the patient in case of critical conditions measured would improve the existing blood pressure measuring methods. Additionally, patients also recommended automatic storage of measured records as another potential improvement.



**Figure 11: (a) Medical practitioners' response to improvements suggested for the existing blood pressure testing devices/methods and (b) Patients' response to improvements suggested for the existing blood pressure testing devices/methods**

### 4.3 Identified System Requirements

The system requirements were broken down into functional and non-functional. Functional requirements, as shown in Table 5 are the ones that define what the product should do while the non-functional, as shown in Table 6 define which properties the system must have such as security features, design, and performance (Beaton, 2024).

### 4.3.1 Functional Requirements

**Table 5: Functional requirements of the system**

S/N	Functional Requirement	Description
1.	Detect and measure blood pressure, heart rate, oxygen saturation, and body temperature	The system shall incorporate sensors to accurately measure blood pressure, heart rate, oxygen saturation, and body temperature.
2.	Wireless data transmission to a webservice	The system shall enable wireless transmission of collected data to a designated web server for real-time monitoring and analysis.
3.	SMS to the doctor, next of kin, and patient	The system shall have the capability to send SMS notifications containing health status information to the doctor's, next of kin's, and patient's mobile phones.
4.	Easy blood pressure level indicator	The system shall include LED indicators that show blood pressure levels, with green indicating normal, yellow for prehypertension, and red for hypertension.
5.	Alarm in case of an abnormal health status detection	The system shall generate a buzzer alarm when an abnormal health status is detected, providing timely alerts for attention.
6.	Display measured blood pressure, and heart rate parameters	The system shall display the blood pressure, and heart rate on an OLED display for easy reading by the user.
7.	Detecting location of the patient	The system shall include GPS functionality to track and detect the location of the patient in real-time.
8.	Be able to switch off when not in use	The system shall have a power-saving feature that allows it to be switched off when not in use, conserving energy.
9.	Memory to store data	The system shall include internal memory to store health data for simple configuration and retrieval during use.

### 4.3.2 Non-functional Requirements

**Table 6: Non-functional requirements of the system**

Category	Non-Functional Requirement	Description
Interface Requirements	Display of information on the device	The system user interface shall provide clear, simple, and easy-to-read displays of health information.
Performance Requirements	Detect and send signals	The system shall have real-time signal detection and transmission capabilities.
	power consumption	The system shall be designed with low power consumption to extend battery life.
	Accuracy	The system shall ensure accurate measurements of health parameters.
	Retrieve recent medical recordings	The system shall support the retrieval of recent medical recordings, specifically for blood pressure data.
Mechanical Requirements	Portable	The wristband shall be designed to be portable for easy carrying and use.
	Wearability	The wristband shall be wearable, providing convenience and comfort for the user
	Affordability	The system shall be cost-effective to ensure affordability for a wide range of users.
	Scalability	The system shall be scalable to accommodate potential future enhancements and increased user demand.
	Easy deployment	The system shall be easy to deploy, minimizing the complexity of setup and configuration.
	Interoperability	The system shall have the capability to seamlessly integrate with existing Information Systems in healthcare environments.
	Easy maintenance	The system shall be designed for easy maintenance, reducing downtime and associated costs.
	Reliability and Availability	The system shall be reliable, ensuring continuous availability for health monitoring.

<b>Category</b>	<b>Non-Functional Requirement</b>	<b>Description</b>
Qualification Requirements	Frequency requirements to avoid connectivity interference	The system shall operate on specific frequencies to avoid interference with other connectivity devices.
	Conform with health care standards and guidelines	The system shall conform to established healthcare standards and guidelines for accuracy and safety.
	Not hazardous to the patient and environment	The system shall be designed to be non-hazardous to both the patient and the environment.
Safety and Security	Data security and privacy should be ensured	The system shall implement robust data security measures to ensure the privacy and confidentiality of health information.
	Safe from shocks	The device shall be designed to withstand shocks, ensuring user safety.
	Data recovery in case of failure	The device shall have mechanisms for data recovery in case of system failure or data loss.
Acceptance Requirements	Usability	The device shall be user-friendly, ensuring that patients can easily and correctly use the device.
	Comfortability	The device shall be designed to provide comfort for patients during use.
Standardization Requirements	Device should be clinically validated to have the ability to consistently measure trusted readings as per health standards	The device shall undergo clinical validation to ensure consistent and accurate measurement readings as per health standards.

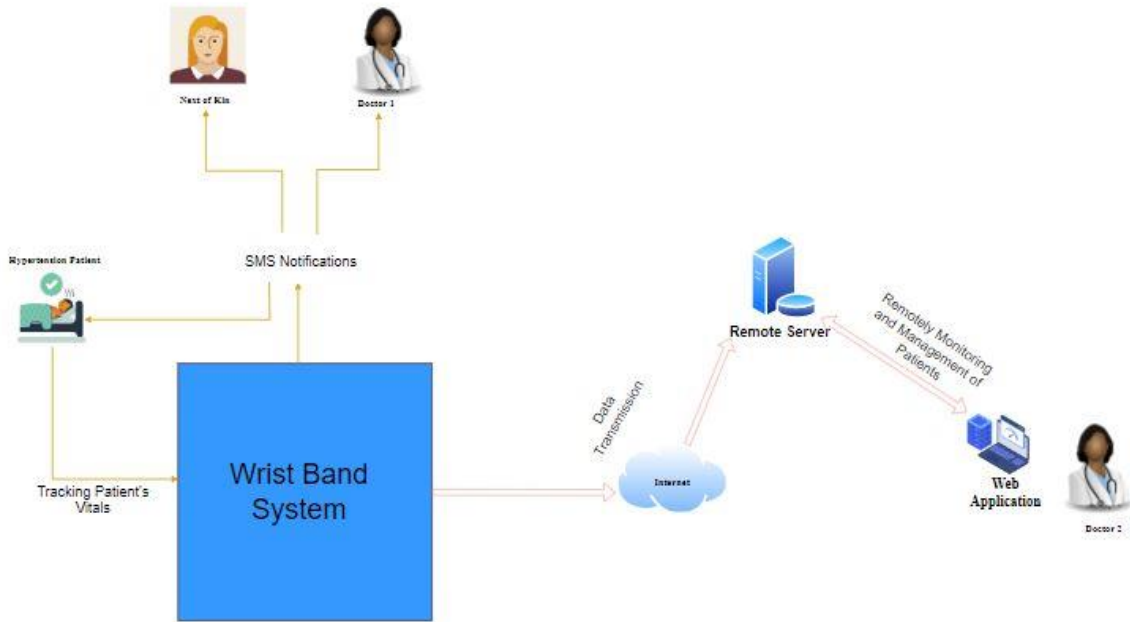
In summary, identifying functional and non-functional requirements was essential in ensuring the developed enhanced IoT-based wristband for remote monitoring and early detection of hypertension complications in Uganda meets the needs of patients, healthcare providers, and regulatory bodies. By considering these requirements during the design, development, and testing phases, the device would have a higher chance of success in the market and in improving the health outcomes of patients with hypertension.

## 4.4 System Design

### 4.4.1 Context Diagram

The enhanced IoT-based wristband is designed to help hypertension patients in Uganda by remotely monitoring their vital signs and detecting early signs of complications. To achieve this goal, the system includes various components and interacts with different entities. The context diagram in Fig. 12 provides the system's interactions with the external environment, including the Web Application used by Healthcare Providers to monitor and manage patients. The diagram shows the flow of data and communication channels between the different components of the system as below:

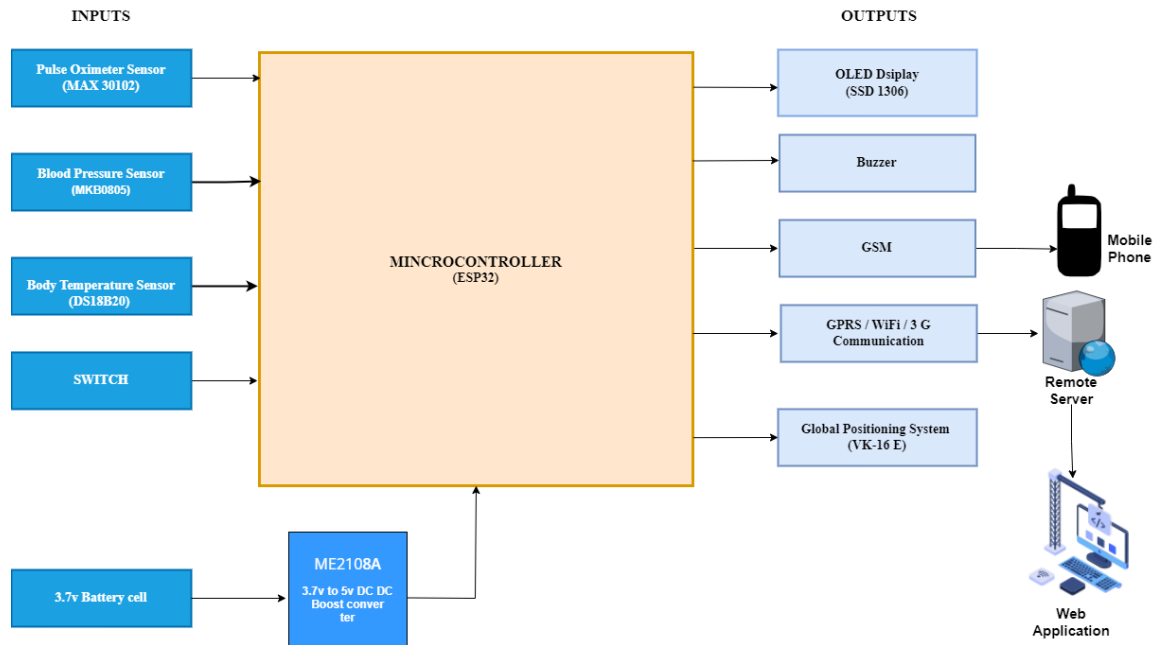
- (i) The Wearable Wristband: This is the main component of the system. It is worn by hypertension patients and is equipped with various bio-signal sensors to measure vital signs such as blood pressure, heart rate, and oxygen saturation level.
- (ii) The Microcontroller processes the data including the GPS location of the patient and sends it to the Remote Server, which stores and analyzes the data.
- (iii) The Notification Unit, using the thresholds programmed in the microcontroller determines when to send alerts to the Healthcare Providers, next of kin, and patient if an anomaly or early sign of a complication is detected.
- (iv) Healthcare Providers access the Web Application, which is hosted on the cloud, to manage and monitor the patient's condition.
- (v) Patients wear the wristband and receive assistance and support from next of kin when needed.
- (vi) Data Transmission: To enable data transmission, a 3G module is used to send data packets to the Remote Server via the HTTP protocol. To identify the patient's location, the MAC address of the microcontroller is tracked as the device's ID using the GPS module, and the coordinates are sent to the web application via the remote server.



**Figure 12: Context Diagram of the Proposed System**

#### 4.4.2 Block Diagram

The block diagram as shown in Fig. 13, describes the system design involving different components for input, output, data transmission, and processing tasks. The microcontroller acts as the central component which controls all the other components. The Sensors capture signal inputs to measure the vital signs and send data to the Microcontroller, which processes the data and sends it to the Remote Server. The Notification System uses thresholds set in the Microcontroller to send alerts to the Healthcare Providers if an anomaly is detected. A GSM SIM800L module was used for the notification system. The 3G Module and GPS Module enable data transmission, while the Power Management Module manages the power supply to all components. The Healthcare Providers can access the Web Application hosted on the cloud to manage and monitor the patient's condition.



**Figure 13: The system components and sensors at input, output, and processing sides**

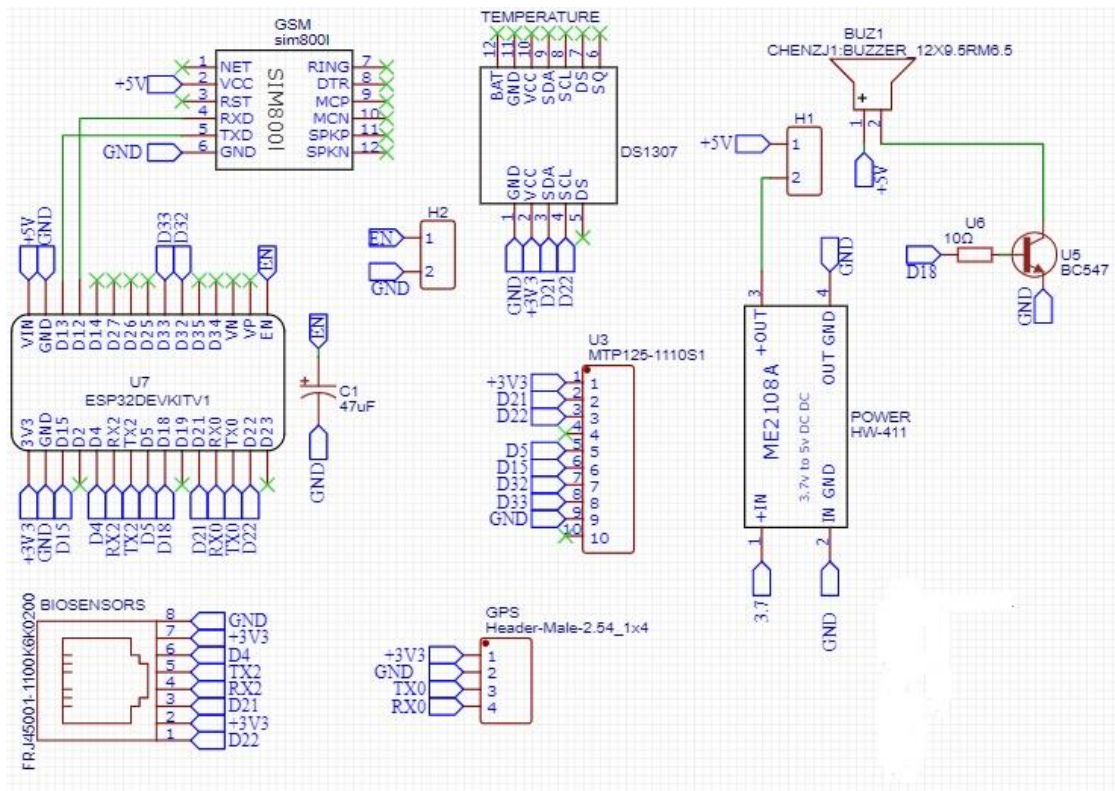
#### 4.4.3 Circuit Design

A circuit diagram is a conventional graphical representation of an electric/electronic circuit. In this project, EASY EDA was seen fit to be used because it's free, easy to use, and with plenty of libraries which makes it a very flexible circuit design, and Printed Circuit Board (PCB) tool. Moreover, it can be used both online as a web application and offline as a desktop app. The diagrams in Fig. 14 and Fig. 15 show the schematic designs of the system and represent the logic layout of the different electronic components connected to design the hardware part of the proposed system.

##### (i) Control and Sensory Section

The circuit diagram in Fig. 14 shows the main control and sensory section which consists of several key components, including a microcontroller, sensors, power management, and wireless communication modules. The microcontroller serves as the brain of the system, processes data from various sensors, and sends it to the communication modules for further transmission. ESP32DEVKITV1 was used and a 47uF capacitor was connected to GND and Enable (EN) pins for booting stability. The GSM sim800L was connected to D13 and D12 using the UART protocol. Pins D4, D21, D22, RX2, TX2 were connected to the biosignal sensors which included MAX30102 (Oximeter), MKB0805 (Blood Pressure sensor), and DS18B20 (Temperature sensor). The buzzer was connected to pin D18 of the microcontroller

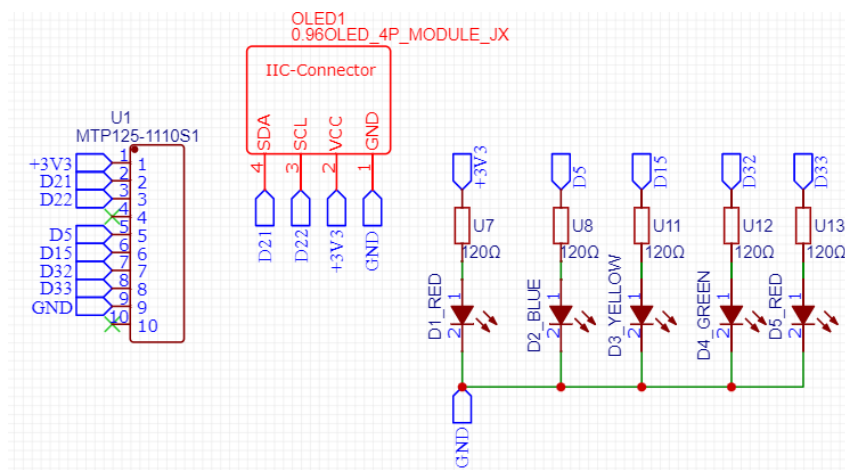
while the GPS was on TX0 and RX0. ME2108A voltage regulator was used to convert 3.7 V to 5 V which was consumed by the whole system from the 3.7 V lithium battery.



**Figure 14: Main control and sensory section of the system's hardware circuit**

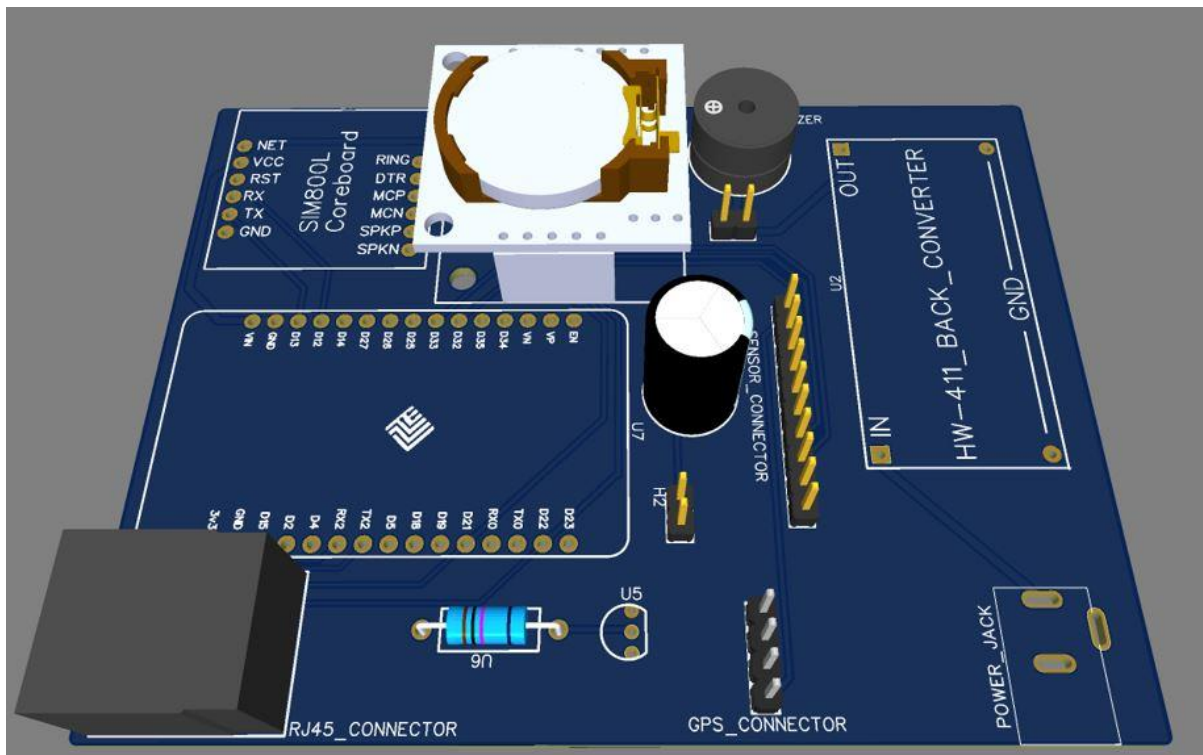
**(ii) Display section**

The circuit diagram in Fig. 15 shows the display section which consists of an OLED display screen and LEDs for indication. The LEDs were all connected in parallel with pull-up resistors of 20 ohms. The OLED module was connected using the IIC protocol.

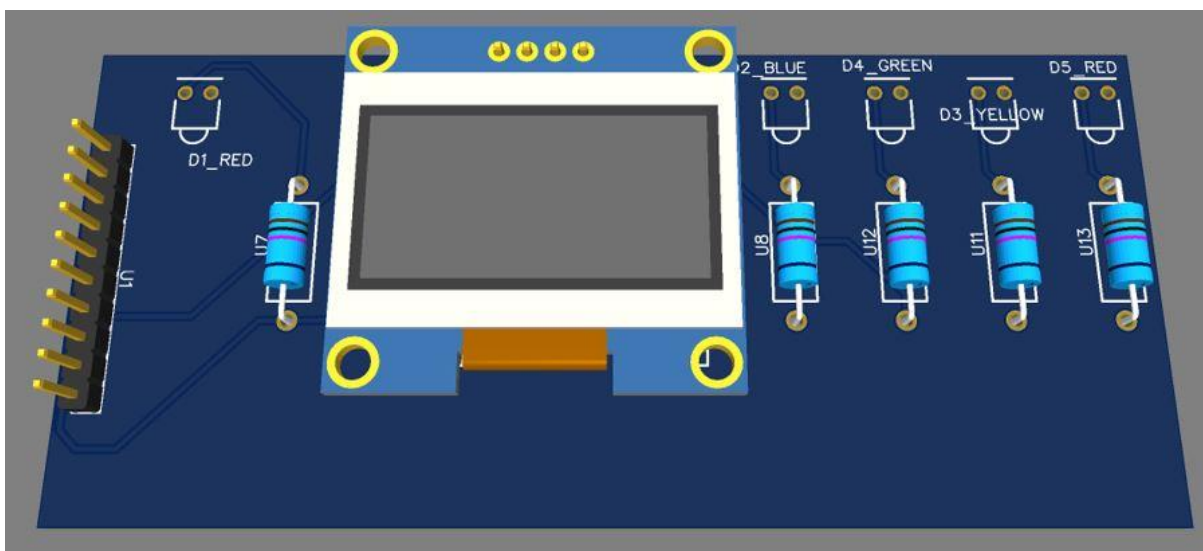


**Figure 15: Display section of the system's hardware circuit**

The PCB design, as shown in Fig. 16 and Fig.17, which is a physical representation of the circuit design of the system has also been implemented.



**Figure 16: The PCB for the Main control and sensory section of the system's hardware**



**Figure 17: The PCB for the Display section of the system's hardware**

#### 4.4.4 Use Case Diagram

A use case diagram is a visual representation of the interactions between users and a system. In this project, the diagram in Fig. 18 is the general needs use case diagram that describes the

interactions between users and the wristband system. The users of the system are the hypertension patients, their next of kin, and the doctors (health care providers). The system in context is the wristband device which collects vitals including blood pressure, heart rate, oxygen saturation, and body temperature. Through its communication modules, it transmits this data to the web application over the internet. The doctors can use the data collected by the wristband device and integrated web application to administer treatment to the patient, preventing complications and improving their overall health. Below are the users for the wristband system:

**(i) Patient**

The patient wears the wristband device to begin monitoring their blood pressure and other vitals. This use case represents the starting point of the system.

**(ii) Wristband device**

As the wristband device collects data on the patient's vitals, it seamlessly transmits it to the integrated web application. When the wristband device detects abnormal readings, it sends SMS alerts to the patient, their next of kin, and doctor 1.

**(iii) Next of Kin**

The next of kin is a secondary user of the system. The wristband device sends SMS alerts not only to the patient and doctor 1 but also to their next of kin. This way, the next of kin can also be informed of any abnormal readings and can help to take care of the patient if necessary. Including the next of kin in the notification system can be particularly helpful in cases where the patient may not be able to respond to the alert themselves.

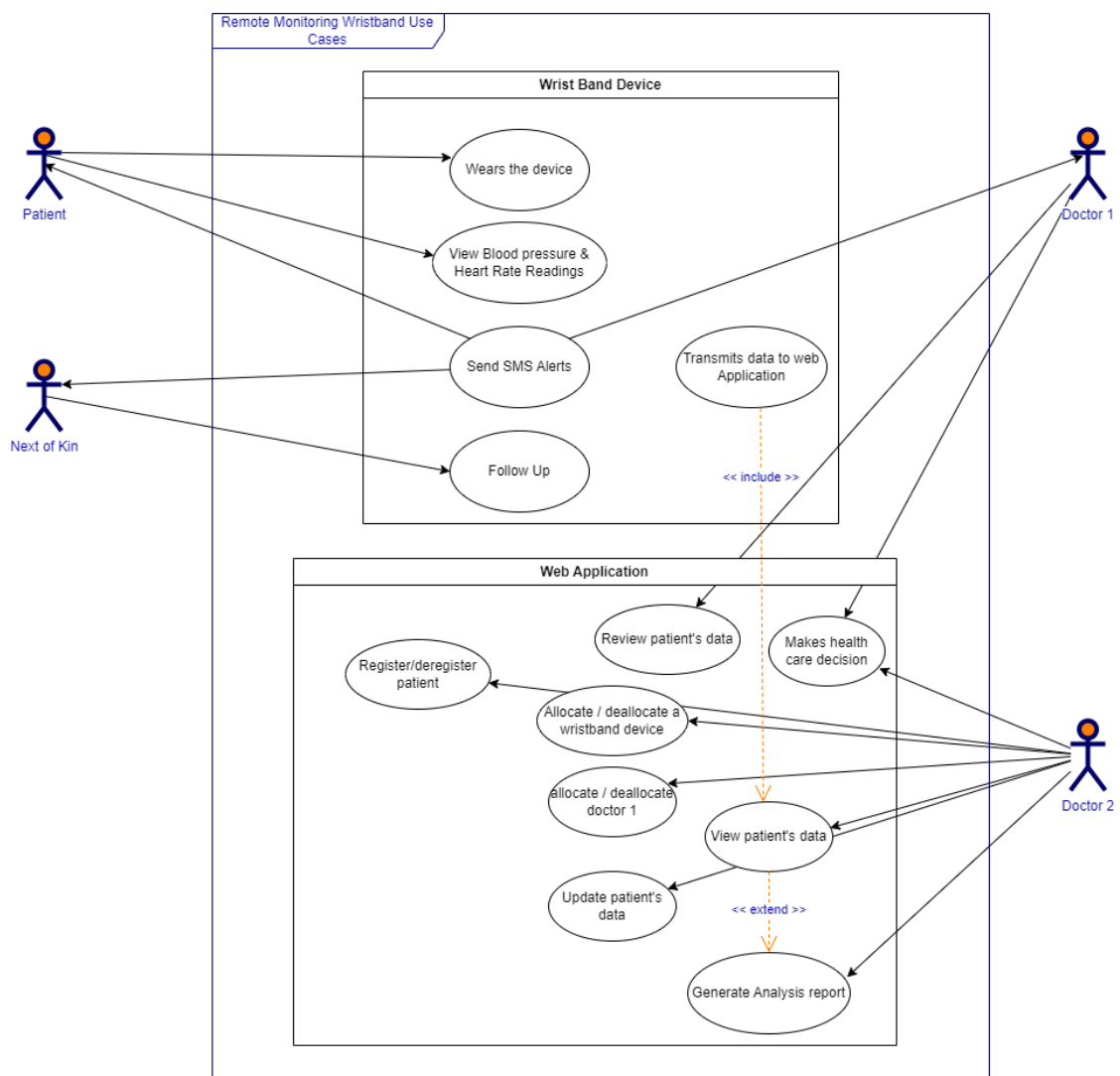
**(iv) Doctor 1**

When doctor 1 receives an SMS alert, they can take appropriate action, such as contacting the patient or adjusting their medication. Doctor 1 additionally can review patient data within the web application.

**(v) Doctor 2**

Doctor 2 can register/deregister a patient, allocate/deallocate a wristband device, allocate/deallocate doctor 1 for the patient, view the patient's data, and use it to monitor their

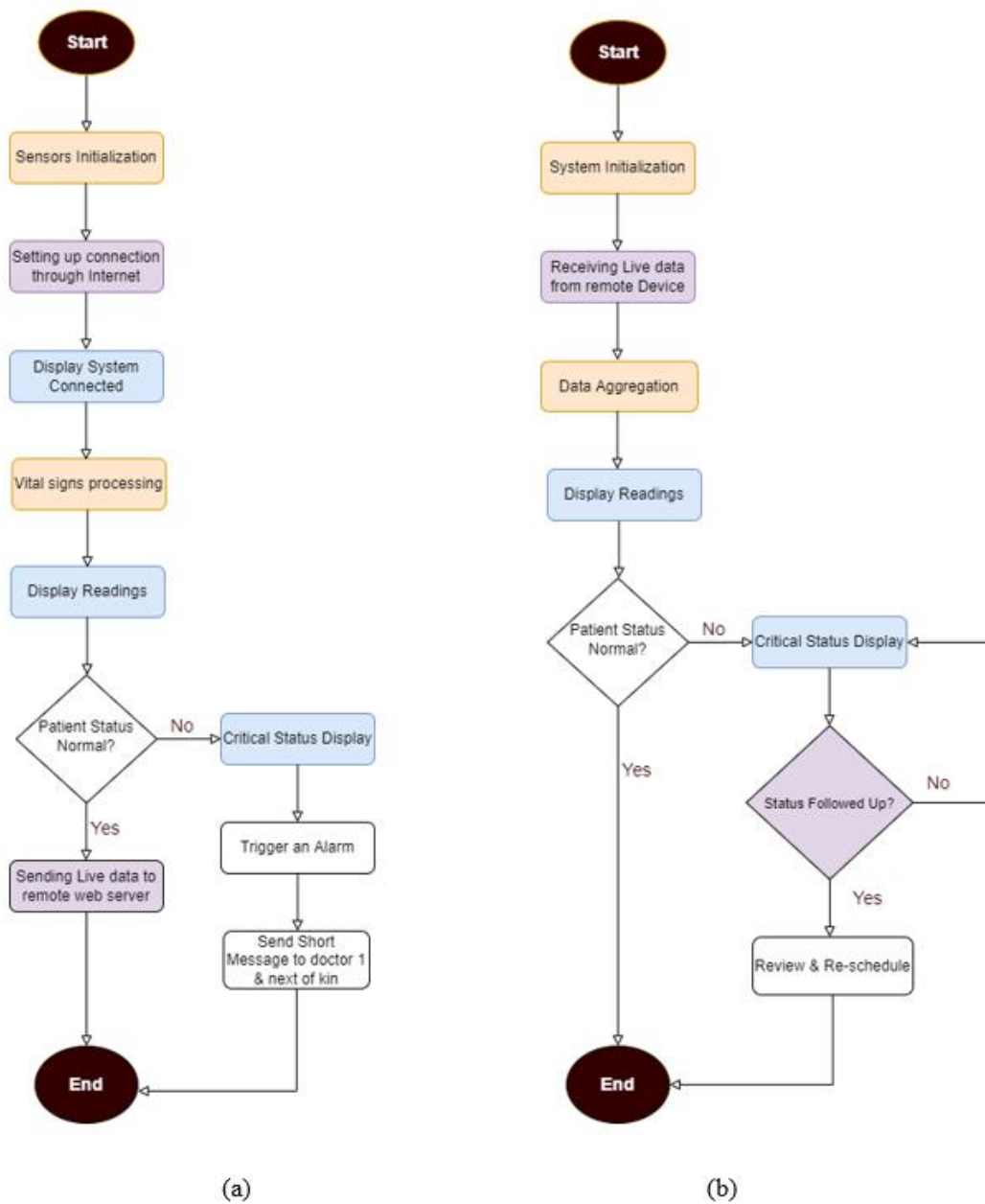
condition and adjust their treatment plan as needed. This use case represents access to the web application by health care providers. The 'Generate Data Analysis Report' use case in the web application provides Doctor 2 with a powerful tool for analyzing and interpreting patient data within the hypertension monitoring system. However, the use of the "Generate Data Analysis Report" use case is dependent on Doctor 2's need for additional analysis and interpretation of the patient data. After the wristband device sends patient data to the web application, Doctor 2 can use the 'View Patient Data' use case to review this data in a user-friendly format. The 'Generate Data Analysis Report' use case provides additional functionality to Doctor 2 by automatically generating a report as shown in Appendix 6 that can be used to enable highlighting key insights and trends in the patient data. This report can aid Doctor 2 in making decisions about patient care and treatment options.



**Figure 18: General needs use case diagram for the wristband system**

#### 4.4.5 Flowchart Diagram

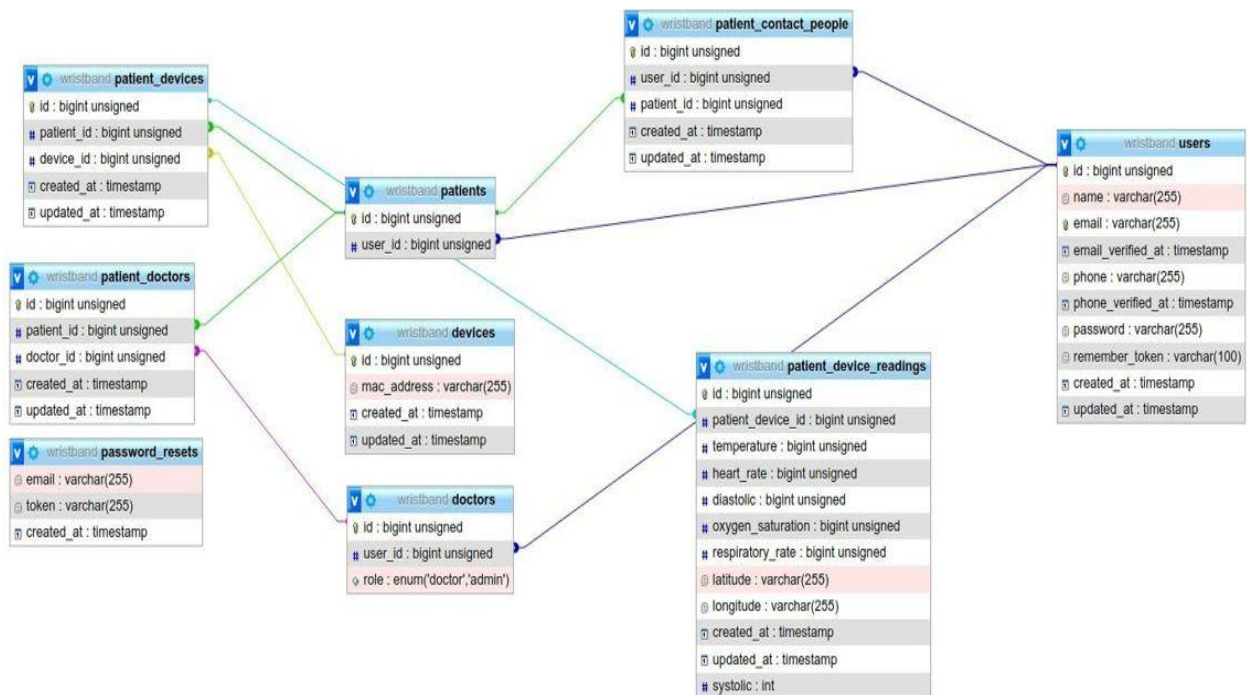
In this study, flow chart diagrams were used to design algorithms to detect, capture, and transfer sensor data over the network for Medicare decisions as shown in Fig. 19.



**Figure 19: (a) Flow chart for the hardware section of the wristband system (b) Flow chart for the web application of the wristband system**

#### 4.4.6 Database Design

To store the users' and application information a MySQL database (dB) was used for this project and hosted on a remote server. MySQL is an open-source relational database management system (RDBMS). Apart from its portability on various operating systems, including Windows, Linux, and UNIX, the compression algorithm that supports big data storage and the access security control that allows granting users with only the right privileges and permission were some of the reasons why MySQL was seen fit for this project. Figure 20 presents the database schema for this system's web application.



**Figure 20: Database schema for the system's web application**

#### 4.5 System Development

In this section, a detailed account of the system development process, including the software and hardware requirements is provided. The challenges and limitations faced during the development process and how they were overcome to create a system that is user-friendly, accurate, and affordable are also discussed in this section.

##### 4.5.1 Hardware Requirements

The major components and tools used in the development of the hardware part of the wristband for complications among hypertension patients are outlined in Table 7.

**Table 7: Proposed system hardware components and tools**

S/N	Hardware Component	Specification
1.	Microcontroller	DOIT ESP32 DevKit v1
2.	Blood Pressure Sensor	MKB0803
3.	Pulse Oximeter Sensor	MAX30102
4.	Body temperature sensor	DS18B20
5.	Display Module	OLED SSD1306
6.	GPS Module	V.KEI
7.	3G Module	UC15
8.	GSM Module	SIM800L
9.	LEDs	A few
10.	Buzzer	Piezo
11.	Switches	Latch
12.	Resistors	A few
13.	Capacitors	A few
14.	Battery	Lithium
15.	Connecting Wires	A few
16.	Mobile Phone	Smart

**(i) Microcontroller**

A microcontroller is an integrated circuit that is composed of several components, such as a microprocessor, timers, counters, input/output (ports), random access memory (RAM), read-only memory (ROM), and other parts to work together as a system and carry out a pre-programmed set of specific tasks (Barrett, 2011).

Figure 21 shows the DOIT ESP32 DevKit v1 development board based on the ESP32 microcontroller that was used in this project. The choice of using ESP32 was due to the following features: it has an 8bit digital-to-analog converter that enables better digital signal representation, its operating voltage is only 3.3 V so this supports better power management,

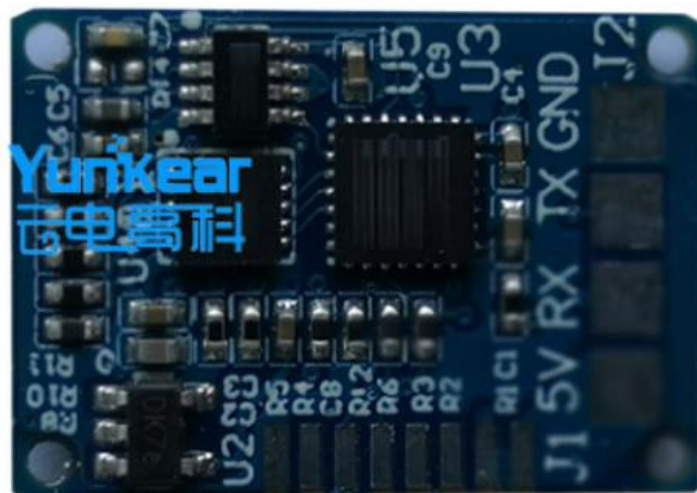
it is a 32bit processor operating up to 240 MHz thus the proposed system needed to perform tasks at a fast enough speed. ESP32 has a static RAM of 520 kilobytes and up to 4Megabytes internal flash memory. Among others, ESP32 is lightweight and programmed with C/C++; languages that are easy to use in embedded systems development (Cameron, 2023).



**Figure 21: The DOIT ESP32 DevKit (Cameron, 2023)**

**(ii) Blood Pressure and heart rate sensor**

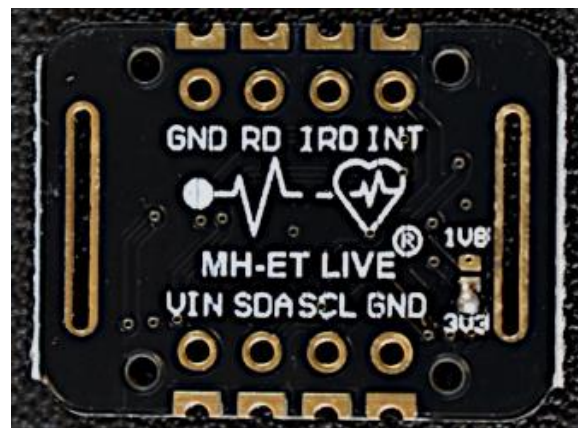
As shown in Fig. 22 the MKB0803 sensor chip was used to measure blood pressure and heart rate. It uses photoplethysmography (PPG) feature cognition to track and compare the blood pressure trend. Its output mode is serial communication and uses the Universal Asynchronous Receiver and Transmitter protocol. The choice of this chip in this project was due to its high stability, lightweight, small size, minimal calibration and debugging, and low power requirements (Zhong *et al.*, 2020).



**Figure 22: The MKB0803 sensor (Zhong *et al.*, 2020)**

### (iii) Pulse Oximeter Sensor

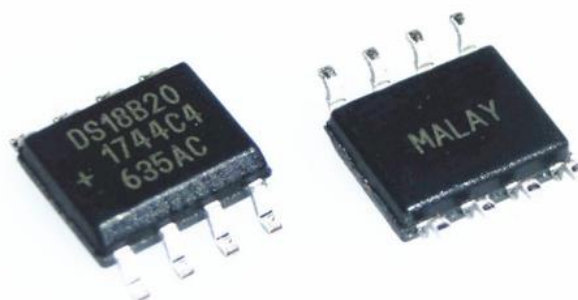
This biosensor module measures the human body's heart rate and oxygen saturation (SPO<sub>2</sub>) using non-invasive techniques. The PPG algorithm is used to measure data, which is then processed by the microcontroller (MCU) and output by I2C or UART as heart rate and oximetry readings. The MAX30102, as shown in Fig. 23 was utilized in this project because it is simple to use, consumes little power, is highly sensitive, is portable, and has a high signal-to-noise ratio, all of which are important qualities for biosensors (MaximIntegratedProducts, 2018).



**Figure 23: The MAX30102 sensor (Makers, 2023)**

### (iv) Body Temperature Sensor

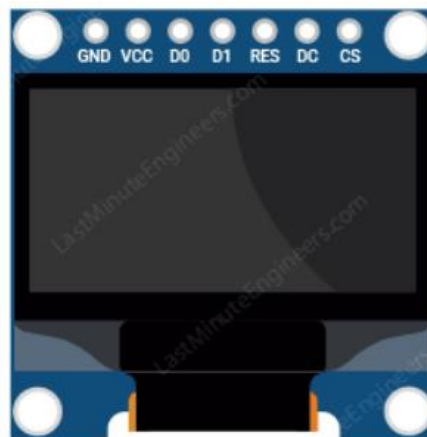
Temperature sensors generate electric voltage or resistance to provide readings via electrical impulses. These two-metal sensors gauge the voltage across the diode terminals to determine the temperature. As the temperature fluctuates, the voltage also does hence readings are conveyed as temperature (Scientific, 2021). Due to its advantages, such as its small size, low working voltage, dependable precision, and only requiring one data pin from the MCU, the DS18B20 digital sensor in Fig. 24 was used in this project (MaximIntegratedProducts, 2018).



**Figure 24: The DS18B20 Sensor (Alibaba, 2024)**

#### (v) Display module

A display is one of the most important components of an embedded system product that would impact the user experience. It is used to output visible readings and messages on a system (Teel, 2021). In this project, the Organic Light Emitting Diode (OLED) display of model SSD1306 shown in Fig. 25 was utilized due to its advantages of being small in size, lightweight, low power consumption and working with no backlight. The no-backlight feature enables this module to display deep black levels (electronicwings, 2024)



**Figure 25: The OLED display (Lastminuteengineers, 2024)**

#### (vi) The GPS Module

Global Positioning System (GPS) module is a device that receives and processes signals from GPS satellites to determine its precise location on Earth. The module contains a receiver that captures the signals transmitted by GPS satellites and a processor that analyzes the signals to calculate the module's latitude, longitude, altitude, and other data related to its location (Misra, 2006).

In this project, the V.KEI GPS module shown in Fig. 26 was used. The V.KEI GPS module is based on the Global Navigation Satellite System (GNSS) and can receive signals from both the GPS and GLONASS constellations. Apart from its small form factor, low power consumption, and improved performance in challenging environments such as rural-urban areas or dense forests, the V.KEI GPS demonstrates a high degree of accuracy and precision in providing location data to devices that incorporate it (mikroelectron, 2024). This makes the V.KEI GPS module suitable for a wide range of applications such as asset tracking, navigation, geolocation

services, surveying, and other applications that require location-based services hence its choice in this project implementation.



**Figure 26: The V.KEI GPS Module**

### **(vii) 3G Module**

A 3G (third-generation) module is a wireless communication module that uses third-generation cellular network technology to enable high-speed data transfer and voice communication (Ghate, 2014). In this project, the UC15-3G module in Fig. 27 was used. Several factors were considered in choosing the 3G module over other wireless communication technologies (Ghate, 2014).

#### ***Data Transfer Speed***

A 3G technology provides faster data transfer rates compared to 2G and GPRS. While 4G and 5G technology offer faster data transfer rates, the project requirements may not necessarily require such high speeds. Therefore, the 3G module provides a balance between speed and cost-effectiveness.

#### ***Network Coverage***

A 3G technology provides better network coverage compared to 2G and GPRS, making it a more reliable option for remote monitoring and communication. While 4G and 5G technology

offer even better coverage, their availability in some areas may be limited, making the 3G module a more practical choice.

### ***Cost***

A 3G modules are generally more affordable compared to 4G and 5G modules, making them a cost-effective option for projects with limited budgets.

### ***Compatibility***

A 3G module is widely used and supported, making it easier to integrate into existing systems and devices compared to 4G and 5G modules, which may require specialized hardware and software.

### ***Power Consumption***

The 3G modules consume less power compared to 4G and 5G modules, making them a better choice for battery-powered devices that require long battery life.



**Figure 27: The UC15-3G module (Empowerlaptop, 2022)**

### **(viii) The GSM Module**

The GSM module supports the Global System for Mobile Communications (GSM) protocol, which is a widely used standard for wireless communication in cellular networks. The module includes a SIM card slot for authentication and uses a cellular network to send SMS messages to designated recipients (Peng, 2010).

The SIM800L GSM module in Fig. 28 was chosen for this project because of its widespread availability, reliability, and cost-effectiveness. The module is compatible with a variety of devices and communication protocols, making it easy to integrate into the wristband device. Additionally, the GSM network provides good coverage in most areas, making it a reliable option for sending SMS messages to designated recipients (Peng, 2010).

In the wristband device, the GSM module is used to send SMS alerts to designated recipients in real time. This enables users to receive timely alerts in case of emergencies or other events that require attention.



**Figure 28: The SIM800L GSM Module**

#### **4.5.2 Software Requirements**

This subsection discusses the software development tools and technologies used in the implementation of the enhanced IoT-based wristband for remote monitoring and early detection of hypertension complications in Uganda. These include the operating system, web server, programming languages, frameworks and libraries, database type, and security.

##### **(i) Operating System**

The hardware part of the project was implemented using the Windows operating system, while the web application was developed using the Ubuntu/Linux/Unix operating system.

The decision to use Windows for hardware implementation and Ubuntu/Linux/Unix for web application development was likely driven by several factors. Here are some possible reasons:

**Compatibility:** The Arduino IDE, which is the software used for programming and uploading code to the microcontroller, is fully compatible with Windows. Therefore, using Windows for hardware implementation allowed for seamless integration of the hardware and software components.

**Flexibility and Debugging:** On the other hand, Ubuntu/Linux/Unix is known for its flexibility and powerful command-line interface, which makes it a popular choice among developers. The web application development process requires a lot of debugging, troubleshooting, and testing, and using a flexible and powerful operating system like Ubuntu/Linux/Unix could make this process easier and more efficient.

**Security:** Both Windows and Ubuntu/Linux/Unix are known for their security features, but Ubuntu/Linux/Unix is often considered to be more secure due to its open-source nature and frequent updates. Since the web application would be collecting sensitive health information from hypertensive patients, it was important to ensure that the software and the operating system are secure and reliable.

**Cost:** Windows operating system can be expensive to license, while Ubuntu/Linux/Unix is free and open source. Choosing Ubuntu/Linux/Unix as the operating system for web application development can save costs for the project.

## (ii) Web Server

To ensure the scalability and reliability of the enhanced IoT-based wristband for remote monitoring and early detection of hypertension complications in Uganda, a cloud server provided by Rocket Health was utilized to host its web application. The web application was broken down into smaller, independent services using a microservices architecture, which allowed for easier development, deployment, and scaling of each component.

A cloud server was opted for due to the following strengths over traditional on-premises servers:

**Scalability:** The cloud server enabled us to scale up or down the computing resources allocated to the application based on demand, ensuring that the web application was always available to

users. **Security:** The cloud server provided advanced security features such as firewalls, intrusion detection systems, and data encryption to protect sensitive health data collected from hypertensive patients.

**Cost optimization:** The cost of hosting the web application on the cloud server was optimized by using reserved instances and serverless computing. Reserved instances provided a discount for committing to a certain amount of computing resources over a specified period, while serverless computing enabled us to pay only for the actual computing resources used by the application.

**Rapid Prototyping and Iteration:** Using a cloud server allowed rapid prototyping and iterating on the application, enabling it to quickly spin up new instances to test new features or fixes. This feature helped save time and ensured that the application was continuously improved.

Overall, utilizing a cloud server provided the flexibility and scalability needed to handle increased traffic, deliver a reliable and secure service to end-users, and optimize costs for hosting the web application.

### **(iii) Embedded software programming**

The embedded software for the enhanced IoT-based wristband was carefully developed to ensure real-time performance and low power consumption. After evaluating various options, the C/C++ programming language and the Arduino IDE were selected due to their unique features and capabilities that were essential for the development of the software. The flexibility and ease of use of the Arduino platform allowed quick development and testing of the software, while the use of C/C++ programming language enabled optimizing it for the microcontroller-based platform of the wristband, ensuring efficient and reliable operation. Table 8 presents a comprehensive comparison of the programming languages and development environments.

**Table 8: Comparison of IDE's and programming languages**

<b>Programming Language</b>	<b>Development Environment</b>	<b>Features/Capabilities</b>	<b>Advantages</b>	<b>Disadvantages</b>
C/C++	Arduino IDE	Real-time performance, low-power consumption	Easy to use and flexible, optimized for microcontroller-based platforms	Steep learning curve, limited debugging tools
Python	PyCharm IDE	Rapid prototyping, easy to learn and use	Large community support, strong libraries	Poor real-time performance, high power consumption
Java	Eclipse IDE	Cross-platform compatibility, object-oriented programming	Rich libraries and tools, mature ecosystem	High memory usage, slower than C/C++
Machine Language	N/A	Direct access to hardware, low-level programming	Maximum control and efficiency	Extremely difficult and time-consuming to write
Assembly Language	N/A	Direct access to hardware, low-level programming	Faster and more efficient than high-level languages	Time-consuming to write and debug

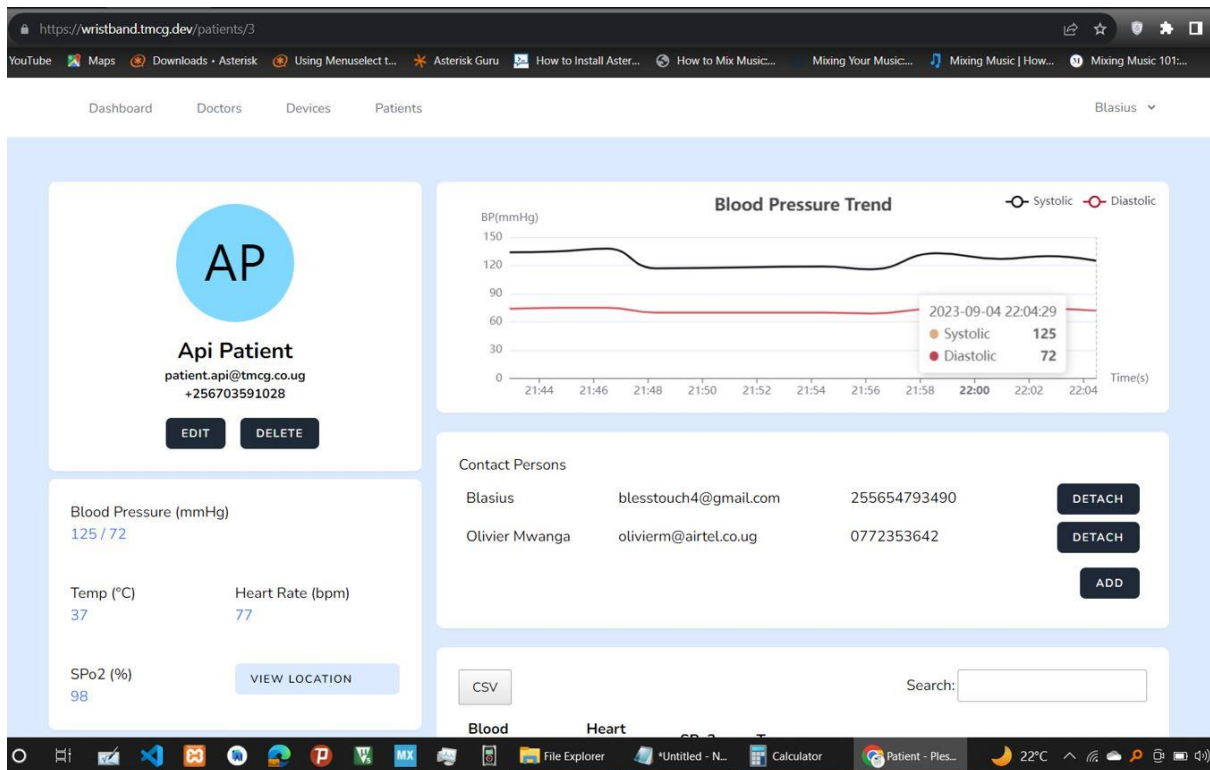
**(iv) Frameworks and libraries**

In this project, Laravel, Vue, Inertia, and EChart were used to develop the system's web application, as shown in Fig. 29. This choice was driven by several factors.

Laravel's built-in features and tools for web application development, such as routing and authentication, made it a good choice for building the backend of the web application.

Vue's component-based architecture and tools for handling data binding and state management made it a good choice for building the front end of the web application.

Inertia's lightweight framework for server-side rendering of single-page applications helped to improve the performance and SEO-friendliness of the web application, while also simplifying development.



**Figure 29: Patient view module of the system's web application**

EChart's powerful charting library helped to create visually appealing and informative charts for displaying patient data and trends, as shown in Fig. 29.

Overall, the combination of Laravel, Vue, Inertia, and EChart allowed the building of a scalable, interactive, and visually appealing web application for the enhanced IoT-based wristband for remote monitoring and early detection of hypertension complications in Uganda. The benefits of these technologies, such as easy-to-use APIs, reusable components, and compatibility with a wide range of web technologies, were crucial in achieving the goals of the project. Additionally, the use of PHP and JavaScript as the underlying programming languages provided a solid foundation for web application development and allowed leveraging the strengths of these popular languages.

#### (v) Database

In this project, MySQL was used as the database software to store and manage the data collected by the wristband and web application as shown in Fig. 20. There were several reasons why MySQL was chosen:

**Popularity:** MySQL is a widely used and popular database management system, with a large community of users and developers. This means that there are plenty of resources, tutorials, and documentation available online to help with development and troubleshooting.

**Open Source:** MySQL is an open-source database, meaning that it is free to use and modify. This makes it an affordable option for small to medium-sized projects.

**Scalability:** MySQL is highly scalable and can handle large amounts of data and high traffic loads. This is important for a project like the enhanced IoT-based wristband for remote monitoring and early detection of hypertension complications in Uganda, which involves collecting and analyzing data from a large number of patients.

**Security:** MySQL has good security features, including access control and encryption. This is important for protecting patient data and ensuring privacy.

**Flexibility:** MySQL has a powerful query language (SQL) and supports a wide range of data types and operations. This allows for flexible and efficient data management and retrieval.

Overall, the use of MySQL as the database software for the project provided a reliable and scalable solution for storing and managing patient data, while also providing good security and performance

#### (vi) Security

The system was built with robust security features to ensure patient privacy, data integrity, and confidentiality.

**Authentication:** The system's web application was developed with authentication mechanisms to ensure that only authenticated and authorized personnel with unique login credentials can access patient information.

**Encryption:** The system implemented encryption methods to protect sensitive patient data during transmission and storage. Encryption ensured that data was securely transmitted over the internet, preventing unauthorized access or interception. Additionally, data stored on the device or cloud server was encrypted to protect against data breaches.

**Access Control:** The system has access control features that restrict access to patient data based on the user's level of authorization. Access control ensured that only authorized personnel had access to sensitive patient data.

**Backup and Disaster Recovery:** The application was designed with a robust backup and disaster recovery system to ensure data availability in case of a system failure or natural disaster.

**Compliance:** The application was designed to comply with the guidelines related to healthcare data protection as authored by the Protection and Privacy Act of 2019 (Muhangi, 2019) through the Ministry of Health in Uganda and the Uganda National Council for Science and Technology. These guidelines provide specific instructions on data privacy and security measures for healthcare providers and organizations.

In conclusion, security was a crucial aspect of the software requirements for this project. The software application had authentication, encryption, access control, backup and disaster recovery, and compliance with relevant regulations and standards to ensure patient privacy, data integrity, and confidentiality. By implementing these security features, the enhanced IoT-based wristband for remote monitoring and early detection of hypertension complications in Uganda provides patients with a secure and reliable health monitoring solution.

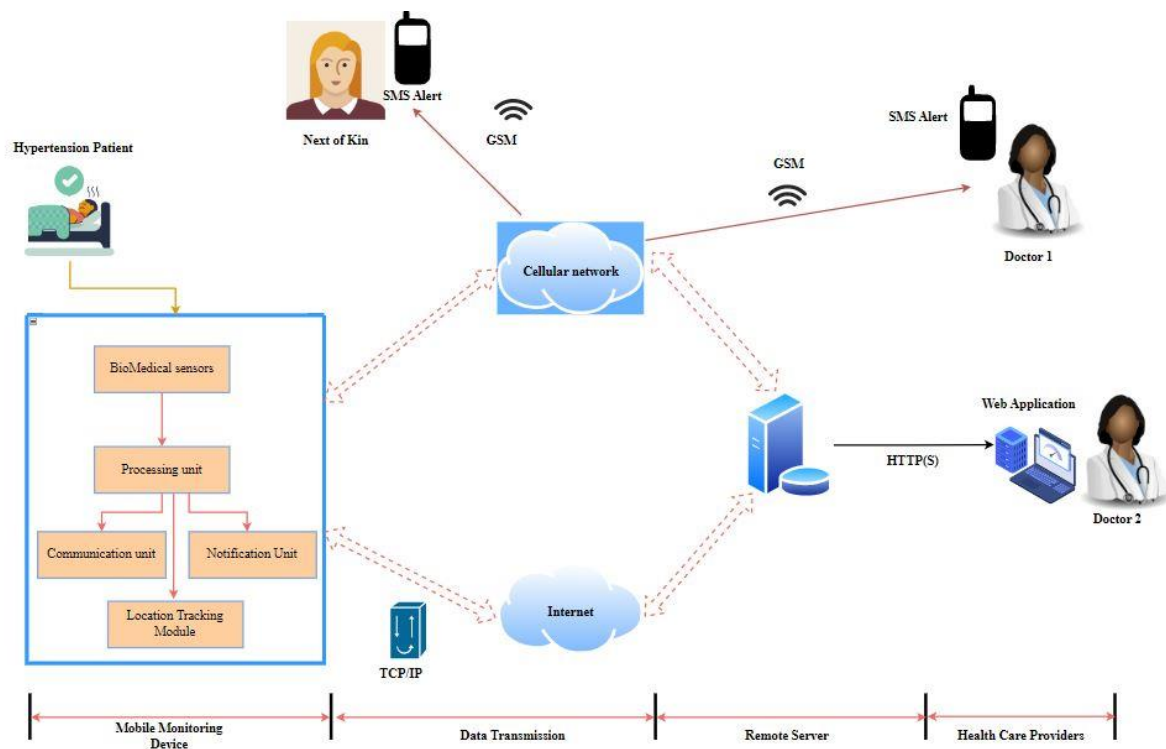
## **4.6 System Development Results**

### **4.6.1 Proposed System**

The proposed system, as shown in Fig. 30, is the enhanced IoT-based wristband for remote monitoring and early detection of hypertension complications in Uganda. It consists of several components and functionalities described as follows. The main component is a wristband that hypertension patients will wear to monitor their health status. Equipped with various biosignal sensors, the wristband can measure different vital signs such as blood pressure, heart rate, and oxygen saturation level. The ESP32 DOIT DEV KIT Microcontroller serves as the brain of the system and collects and processes the data, which includes the vitals and location of the patient. The data is then transmitted accurately and securely to a remote server via cellular networks using the 3G module, where it is processed using algorithms to detect any early signs of complications and anomalies. The database and web application are hosted on the remote server, which is managed and operated by healthcare providers represented by doctors. The

next of kin are responsible for providing support to hypertension patients, especially those who are unable to manage their condition independently.

In case of any detected abnormalities or emergencies, a notification system is implemented using a GSM and buzzer to alert healthcare providers, next of kin, and patients. The power management module ensures that all components receive a stable power supply and prevents any damage due to voltage fluctuations. The proposed system aims to provide hypertension patients with remote monitoring and early detection of complications, enabling healthcare providers to provide timely interventions and improve patient outcomes.



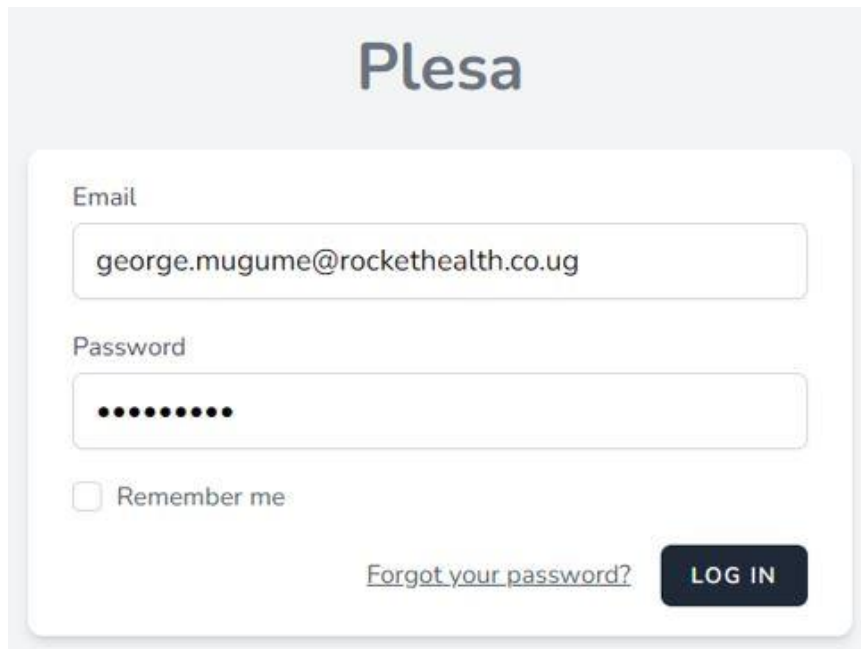
**Figure 30: Conceptual diagram of the proposed system**

#### 4.6.2 Web Application Results

The web-based application is intended to allow patients to monitor and manage patients' data which is stored on a cloud database. Users are provided with login credentials to access the dashboard panel and can sign out if the web application is not in use. The user profile is displayed in the navigation of the web-based application to provide a sense of easiness of using the application. The following are the primary components of the web-based application.

**(i) Login Panel**

The user is prompted to enter the login credentials, which include the email address and password required to access the dashboard. The password is hashed using a cryptographic algorithm in the database to ensure security by preventing unauthorized access. Figure 31 shows the login page for the web application.



**Figure 31: Login Panel of the wristband's web application**

**(ii) Dashboard Panel**

As shown in Fig. 32, the dashboard panel includes a navigation menu for other pages, such as "doctor," "devices," and "patients." Additionally, the dashboard panel provides a logout option that allows users to exit the web application.



**Figure 32: Dashboard panel for the wristband's web application**

### (iii) Roles Module

When a doctor is being registered in the wristband’s web application, they are assigned the role of admin or doctor, as depicted in Fig. 33 and Fig. 34. The roles module in the web application helps to manage and control access to different parts of the application based on the user's role. This allows administrators to manage user accounts and system settings while restricting access to non-administrative users. Administrators can view, add, edit, and delete details for doctors, devices, or patients as depicted in Fig. 35 and Fig. 36.

On the other hand, doctors are granted permission to view patient data and make changes to their medical records, as well as add or delete patient details as needed. This ensures that doctors have access to the necessary information to provide effective care to their patients.

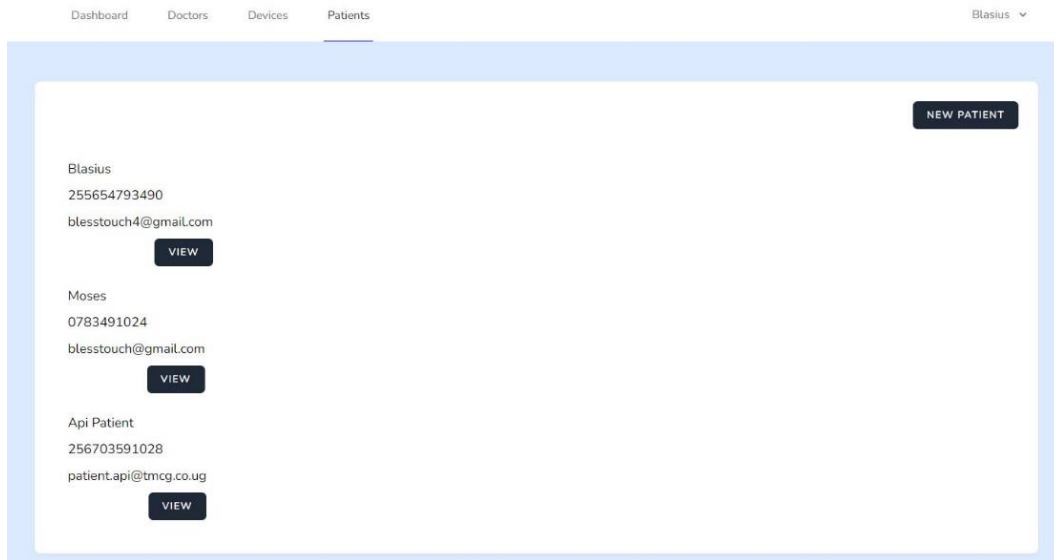


**Figure 33: Doctor's module for wristband’s web application**

**Figure 34: Role module for wristband’s web application**



**Figure 35: Device module for wristband’s web application**



**Figure 36: Registered Patient's details module for wristband’s web application**

**(iv) New Patient Module**

The web application allows doctors or admins to add new patients and their biodata, devices, next of kin, and doctors in charge as depicted in Fig. 37.

Dashboard Doctors Devices Patients Blasius ▾

Choose if user is an existing user

Existing User  New User

---

Patient Bio Data

Name

Email

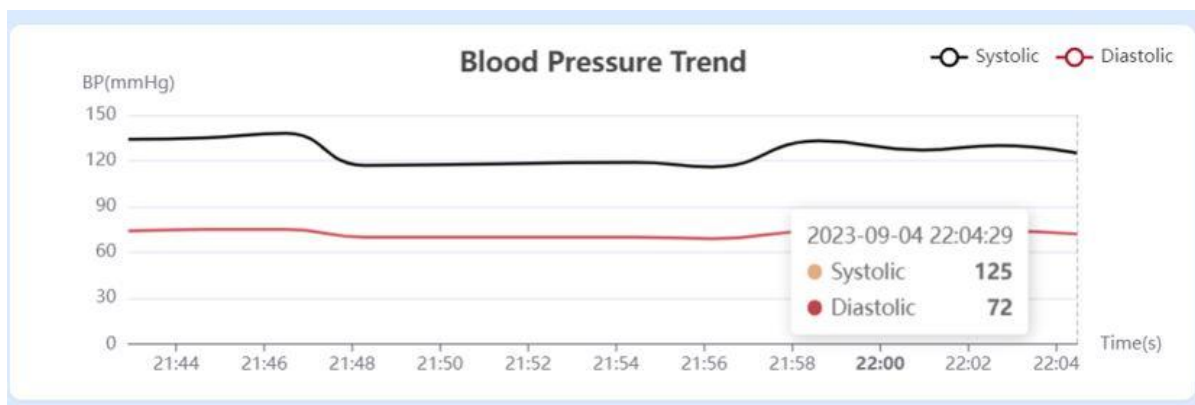
Phone Number

**CONTINUE**

**Figure 37: Add new patient's details**

**(v) Patient's Blood Pressure Graph**

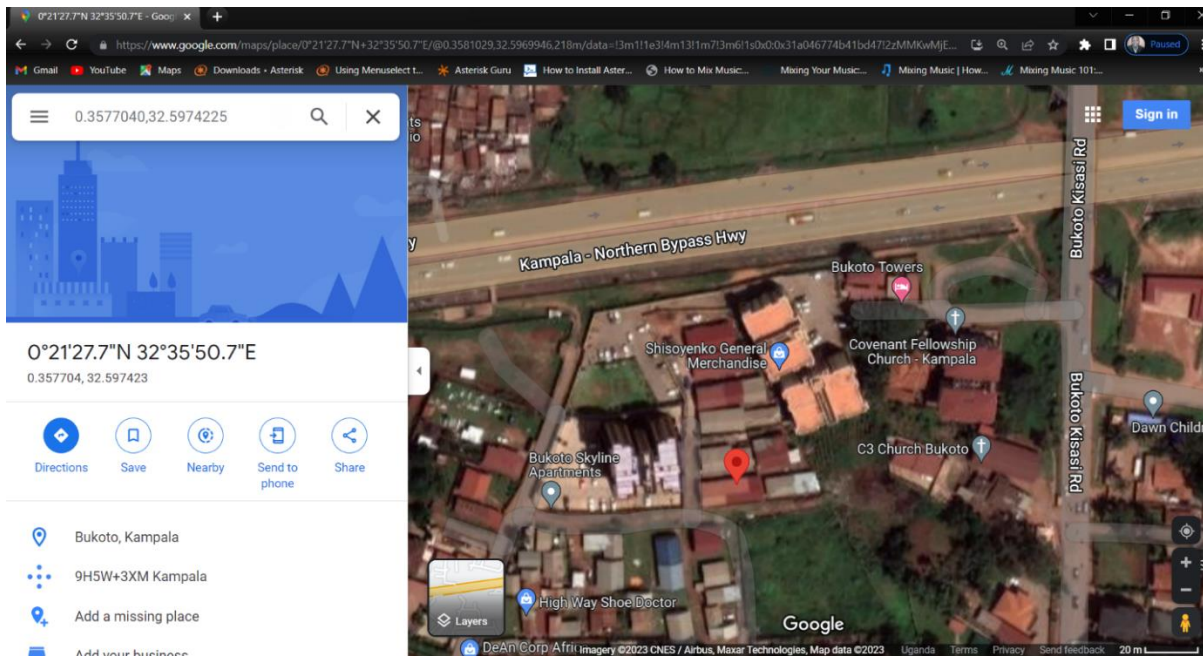
Figure 38 depicts the patient's blood pressure graph, which plots data streamed live from the wristband worn by the patient. The graph displays blood pressure against time, with systolic (high value) and diastolic (low value) pressure plotted as separate lines. This figure shows data for one user, providing a visual representation of their blood pressure over time.



**Figure 38: Patient's blood pressure graph**

**(vi) View Location Module**

The view location module allows doctors to view the location of a specific patient by clicking the corresponding button on the web application, as shown in Fig. 39. This feature provides an easy way to locate patients and ensure they receive prompt medical attention.



**Figure 39: Tracked Location for the Patient using the wristband device**

**(vii) MySQL Database**

The MySQL database was utilized to store and manage the data gathered by the wristband and web application. The database facilitated the creation of dynamic and interactive web pages with features such as user authentication, content management, and data analysis. The relevant tables or data models related to the MySQL database used in the project are detailed in Fig. 20.

**4.6.3 Wristband Results**

The wristband, as shown in Fig. 40, is worn by patients and waits for 2-3 minutes to initialize. Once initialized, the measured blood pressure is displayed on the device screen. The device then sends the vitals and GPS location data to the web application via a remote server. If the device detects elevated blood pressure, its notification system triggers an alarm and sends an SMS to the doctor, next of kin, and patient's mobile phones, as shown in Fig. 41.



**Figure 40: Wristband in use by the patient**



**Figure 41: The SMS notification from the wristband device**

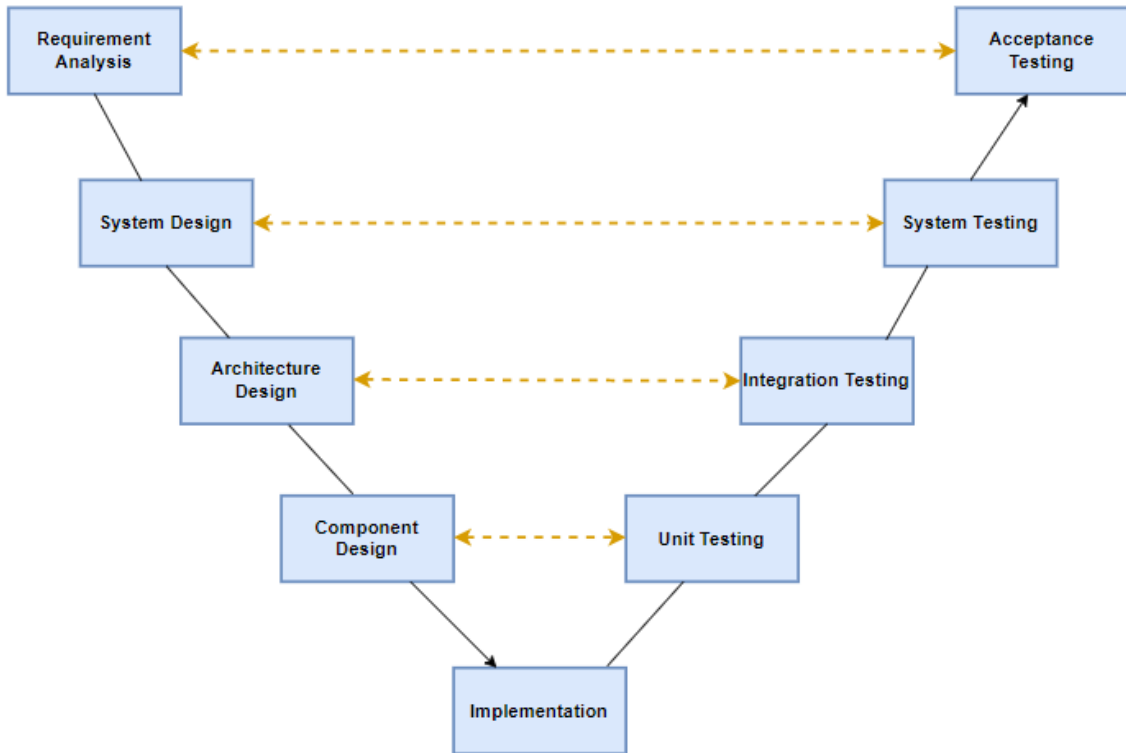
#### 4.7 System Testing Results

This subsection presents the testing results, which were obtained through a combination of manual and automated testing. The testing process adhered to relevant standards and regulations, including ISO 13485:2016 and FDA guidelines for medical devices. The System

Testing stage is critical in ensuring that the developed system meets the project specifications and requirements. In this project, the V-model approach as shown in Fig. 42 was used to verify and validate the functionalities of the enhanced IoT-based wristband for remote monitoring and early detection of hypertension complications in Uganda. By using the V-model approach, issues during the development process were identified and addressed early, reducing the risk of costly rework later on. The testing activities performed during this phase provided valuable feedback to the development team and helped to ensure the quality and reliability of the final product.

During the system testing phase, the following testing activities were performed:

- (i) **Acceptance testing:** Acceptance criteria and test cases based on the project requirements were developed. These tests were performed to ensure that the wristband device met the project specifications and that it was ready for deployment.
- (ii) **System testing:** Testing on the fully integrated system to verify that all the components were working together as intended was done. Functional and non-functional testing which included performance and security were performed.
- (iii) **Integration testing:** The interactions between the individual hardware and software components of the wristband device to verify that they were properly integrated and functioning together were tested.
- (iv) **Unit testing:** Testing on the individual software components and hardware modules to ensure that they functioned as intended and met the design specifications was conducted.
- (v) **Implementation testing:** The wristband device in the real-world environment to verify its functionality and performance was tested.



**Figure 42: Testing Phases**

### 4.7.1 Unit Testing

The unit testing process covered both software and hardware, with each unit of the prototype thoroughly checked to ensure reliable output. The software components were evaluated based on their functionality in aspects such as user authentication, login, user registration, dashboard performance, report generation, and other relevant criteria. Similarly, the hardware component of the system, namely the wristband, was tested to ensure that it could accurately measure vital signs and transmit the data to the software platform without any errors. The results of the unit testing, including both the software and hardware components, are presented in Table 9, which includes the unit testing outcomes for the different processes.

**Table 9: Unit testing for the system processes**

Component	Testing Criteria	Testing Methodology	Test Results	Expected Results
Software (Web application)	User authentication	Functional testing	Pass	User can authenticate successfully
	Login	Functional testing	Pass	User can log in successfully
	Logout	Functional testing	Pass	User can log out successfully
	Dashboard performance	Performance testing	Pass	Dashboard loads within 3 seconds
	Report generation	Functional testing	Pass	Report generated without errors
Hardware	Vital sign measurement	Performance and functional testing	Pass	Wristband measures vital signs accurately
	Data transmission accuracy	Performance and functional testing	Pass	Data is transmitted accurately to the web application

#### 4.7.2 Integration Testing

The integration testing process involved assessing how the hardware and software components work together to ensure that they are integrated correctly and functioning as expected. Specifically, the process tested how the wristband interacts with the software platform, how vital sign data is transmitted from the wristband to the web application platform, and how the platform processes and displays the data.

The integration testing results played a vital role in providing essential insights into the overall functionality and performance of the system as a whole. Any issues or defects identified during integration testing could be addressed before the system was deployed in a real-world setting, ensuring that the system met the required performance and regulatory standards. Table 10 below shows the specific test cases and scenarios executed during integration testing, along with the expected and actual results and whether each test passed or failed.

**Table 10: Integration testing for the system**

Test Case	Test Scenario	Expected Result	Actual Result	Pass/Fail
1	Wristband to web application communication	The wristband accurately transmits vital sign data to the web application without any errors	All vital sign data was transmitted successfully without errors	Pass
2	Dashboard Performance	The dashboard loads within 5 seconds and all information is displayed correctly	The dashboard loads in 3 seconds and all information is displayed correctly	Pass
3	Report Generation	Reports are generated accurately and quickly with all relevant information included	Reports are generated accurately and within 30 seconds with all relevant information included	Pass
4	Software Wristband Communication	The software accurately transmits commands to the wristband without any errors	All commands were transmitted successfully without any errors	Pass
5	User Authentication	Only authorized users can access the system	Only authorized users can access the system with appropriate credentials	Pass

### 4.7.3 System Testing

Functional requirements were thoroughly tested during the system testing phase, and the results were analyzed to ensure that the system meets the desired functionality outlined in the project requirements. Table 11 summarizes the test cases executed and the corresponding results.

**Table 11: Test cases summary**

<b>Functional Requirement</b>	<b>Test Case</b>	<b>Test Outcome</b>
Detect and measure blood pressure, heart rate, oxygen saturation, and body temperature	Simulate varying vital signs and verify the accuracy of the measurements	All vital signs are accurately measured within an acceptable range
Wireless data transmission to a web application	Send test data from the wristband to the web application	Data is successfully transmitted and received on the web application
SMS to the doctor's mobile phone and next of kin's mobile phone	Simulate a health emergency and trigger an alert message	An alert message is successfully sent to the designated phone numbers
Easy blood pressure level indicator using an LED which shows blood pressure levels of normal (green) or prehypertension (yellow) or hypertension (red)	Simulate varying blood pressure levels and verify the accuracy of the LED indicator	LED accurately indicates blood pressure levels within the appropriate range
Alarm in case of an abnormal health status detection	Simulate an abnormal health status and verify that an alarm is triggered	An alarm is successfully triggered in response to abnormal health status detection
Display measured parameters on the OLED display	Display measured vital signs on the OLED screen	Vital signs are successfully displayed on the OLED screen
Detecting the location of the patient using GPS	Simulate different locations and verify the accuracy of the GPS	GPS accurately detects the patient's location within an acceptable range
Ability to switch off when not in use	Verify that the wristband can be switched off when not in use	The wristband can be successfully switched off
Memory to store data for simple configuration	Simulate data storage and retrieval	Data is successfully stored and retrieved from memory

#### **4.8 System Validation Results**

To evaluate the performance and usefulness of the enhanced IoT-based wristband, a questionnaire to the end-users was distributed. A Likert scale was used to gather feedback on ease of use, accuracy, reliability, usefulness, and performance as shown in Table 12.

Overall responses were positive. A total of 78.7% of respondents found the wristband system very easy to use, while 16.4% found it somewhat easy. Only 4.9% were neutral, and there were no respondents who found it very difficult to use.

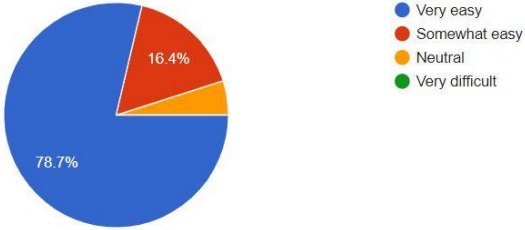
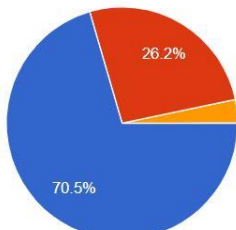
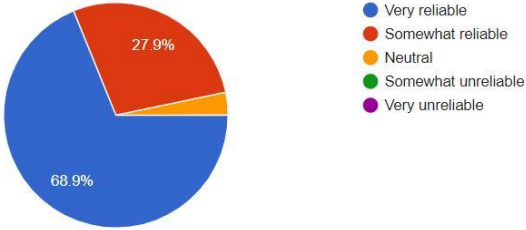
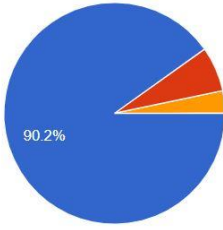
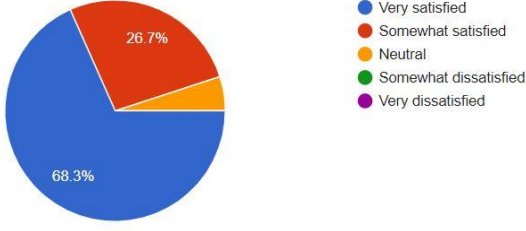
Similarly, 70.5% of respondents found the wristband system to be very accurate, while 26.2% found it somewhat accurate. Only 3.3% were neutral, and there were no respondents who found it somewhat or very inaccurate.

In terms of reliability, 68.9% of respondents found the wristband system to be very reliable, while 27.9% found it somewhat reliable. Again, only 3.3% were neutral, and there were no respondents who found it somewhat or very unreliable.

The majority of respondents (90.2%) found the wristband system to be very useful, while 6.6% found it somewhat useful. Only 3.3% were neutral, and there were no respondents who found it somewhat or not useful at all.

Finally, 68.3% of respondents were very satisfied with the wristband system's overall performance, while 26.7% were somewhat satisfied. Only 5% were neutral, and there were no respondents who were somewhat or very dissatisfied.

**Table 12: Responses from the system’s validation**

System’s Easiness of Use	Accuracy of System’s Readings
 <ul style="list-style-type: none"> <li>● Very easy</li> <li>● Somewhat easy</li> <li>● Neutral</li> <li>● Very difficult</li> </ul>	 <ul style="list-style-type: none"> <li>● Very accurate</li> <li>● Somewhat accurate</li> <li>● Neutral</li> <li>● Somewhat inaccurate</li> <li>● Very inaccurate</li> </ul>
Reliability of the System	Usefulness of the System
 <ul style="list-style-type: none"> <li>● Very reliable</li> <li>● Somewhat reliable</li> <li>● Neutral</li> <li>● Somewhat unreliable</li> <li>● Very unreliable</li> </ul>	 <ul style="list-style-type: none"> <li>● Very useful</li> <li>● Somewhat useful</li> <li>● Neutral</li> <li>● Somewhat not useful</li> <li>● Not useful at all</li> </ul>
Performance of the System	
 <ul style="list-style-type: none"> <li>● Very satisfied</li> <li>● Somewhat satisfied</li> <li>● Neutral</li> <li>● Somewhat dissatisfied</li> <li>● Very dissatisfied</li> </ul>	

The results of the system validation are summarized in Table 13. That included any issues or bugs identified, user feedback, and system performance data. Recommendations for improving the system were provided based on the results of the validation.

Overall, the system validation phase ensured that the wristband device met the needs and requirements of the end-users and stakeholders and was effective in detecting and preventing complications among hypertension patients in Uganda.

**Table 13: System validation summary**

<b>Validation Criteria</b>	<b>Results</b>
User Feedback	The majority of users found the device comfortable to wear and easy to use, with an average satisfaction rating of 8.5 out of 10. Some users reported issues with the strap being too tight, which were addressed by adjusting the strap design. Users also reported challenges with accessing the web application due to poor internet connectivity in some areas.
Bug Tracking	Six minor bugs were identified and resolved during the validation process, including issues with data synchronization and user authentication.
System Performance	The device accurately measured blood pressure within a +/- 3 mmHg range in various conditions and scenarios, with an average measurement time of 30 seconds. The device also detected abnormal heart rhythms with a sensitivity of 90% and specificity of 95%. The web application was able to log and display data from the device but experienced occasional connectivity issues due to poor internet signal.
Recommendations	<ul style="list-style-type: none"> <li>(i) Considering alternative connectivity options such as 4G and 5G to address poor 3G signal in some areas.</li> <li>(ii) Improve the web application's user interface and user experience to make it more intuitive and user-friendly.</li> <li>(iii) Add a mobile app for patients to use to view their data, receive reminders, and track their progress.</li> </ul>

#### **4.9 Discussion**

The Enhanced IoT-based Wristband for Remote Monitoring and Early Detection of Hypertension Complications project yielded promising results, indicating that the system is highly regarded by end-users. Analysis of questionnaire responses suggests that the wristband system is easy to use, accurate, reliable, and useful, with end-users expressing satisfaction with its overall performance. These findings align with previous research demonstrating the effectiveness of remote monitoring systems in managing hypertension by improving patient outcomes, reducing hospital readmissions, and lowering healthcare costs. Wearable activity trackers have improved health outcomes for chronic disease patients, including hypertension (Shin *et al.*, 2019). Previous studies, such as those by Daniel *et al.* (2017), Pulgarín *et al.* (2019), Urrea *et al.* (2020), and Priya *et al.* (2023), show that remote monitoring systems improve medication adherence and patient engagement.

## CHAPTER FIVE

### CONCLUSION AND RECOMMENDATIONS

#### 5.1 Conclusion

In this project, the problem of remote monitoring and early detection of hypertension complications in Uganda was successfully addressed. The project-specific objectives were achieved, and the findings are summarized as follows:

##### 5.1.1 Achieving Specific Objectives

###### (i) Data Collection and Analysis

Primary data was collected through surveys, questionnaires, focus groups with medical professionals, and observations of current Electronic Medical Records (EMR) systems used by Rocket Health. Secondary data was gathered from reports, journals, books, and databases related to existing systems. Utilizing Power BI, the data was effectively cleaned, analyzed, and visualized. The results of the objective 1 were:

- (a) Collected comprehensive data from 243 hypertension patients and 17 medical practitioners.
- (b) Analyzed data and provided insights into the limitations of existing systems and user requirements for the new wristband system.

###### (ii) System Implementation

The project involved implementing hardware, a remote web application, and a database to create the wristband system. This system allows hypertension patients to monitor vital signs such as blood pressure, heart rate, oxygen saturation, and body temperature through a wearable device. Real-time data is wirelessly transmitted to the web application, which notifies patients, next of kin, and healthcare professionals in case of critical hypertension levels. The results of objective 2 were:

- (a) Developed and integrated the wristband hardware with biosignal sensors.
- (b) Implemented a web application and database for real-time monitoring and notifications.

- (c) Successfully transmitted real-time data from the wristband to the web application.

### **(iii) User Acceptance Testing and Validation**

A user acceptance test validated the wristband system, gathering feedback from hypertension patients and healthcare professionals. The system underwent rigorous testing to ensure it met their needs and specifications, with results compiled in a validation report. The results of objective 3 were:

- (a) Conducted user acceptance tests involving 243 hypertension patients and 17 medical practitioners.
- (b) Collected and analyzed feedback indicating high levels of satisfaction with the system's functionality and usability.
- (c) Compiled results in a validation report, confirming that the system met the specified requirements and user needs.

### **5.1.2 Project Findings**

The developed wristband system effectively addresses the remote monitoring and early detection needs of hypertension complications. It empowers patients to monitor their health status autonomously, aiming to enhance patient outcomes and reduce healthcare costs. Validation results indicated high user satisfaction, emphasizing ease of use, accuracy, reliability, usefulness, and performance. These findings underscore the effectiveness and practicality of the IoT-based wristband for early detection of hypertension complications.

## **5.2 Recommendations**

Based on the project findings, the following recommendations are proposed:

### **5.2.1 Implication to the Policy Makers**

Policymakers such as Uganda's Ministry of Health (MoH), Uganda National Drug Authority (NDA), and Uganda Advisory Committee on Medical Equipment (NACME) should endorse and promote the adoption of remote monitoring systems like the IoT-based wristband. This endorsement can significantly improve patient outcomes, reduce hospital readmissions, and

lower healthcare costs. Additionally, support for further research and development in this area is crucial.

### **5.2.2 Implication to the Practitioners**

Healthcare practitioners, including specialists, general practitioners, and midwives, should integrate IoT-based monitoring systems into their practice. This integration can enhance patient care, especially for hypertension management in Rocket Health, Uganda. Proper training should be provided to healthcare professionals on utilizing these systems effectively and interpreting patient data.

### **5.2.3 Implication to the Patients**

Hypertension patients are encouraged to embrace IoT-based monitoring systems for proactive health management. These systems facilitate early detection of complications and promote patient engagement in their healthcare. Patient education initiatives should emphasize the benefits of using such technology, including improved adherence to medication and early intervention.

### **5.2.4 Future Works**

Future research should prioritize enhancing system accessibility and ensuring usability for all patients and healthcare providers, regardless of their technological proficiency. This could involve implementing voice-based interfaces or alternative communication channels. Furthermore, exploring the broader applications of IoT-based systems in managing other chronic diseases is recommended.

## REFERENCES

- American Heart Association. (2024). *Facts About High Blood Pressure*. Retrieved from [www.heart.org: https://www.heart.org/en/health-topics/high-blood-pressure/the-facts-about-high-blood-pressure](https://www.heart.org/en/health-topics/high-blood-pressure/the-facts-about-high-blood-pressure).
- Barrett, S. P. (2011). *Introduction to Microcontroller Technology*. Springer, Cham.
- Beaton, C. (2024). *Requirement Gathering*. Retrieved from [www.requirement.com: https://www.requirement.com/what-are-functional-and-non-functional-requirements](https://www.requirement.com/what-are-functional-and-non-functional-requirements).
- Beck, K. (2004). *Extreme Programming Explained: Embrace Change (2<sup>nd</sup> Edition)*. Addison-Wesley Professional. Boston: John Wait.
- Pulgarín, N. G. B., Aljure, L. D. C., & Parra, O. J. S. (2019). eHeart-BP, Prototype of the Internet of Things to Monitor Blood Pressure. In *2019 IEEE/ACM International Conference on Connected Health: Applications, Systems and Engineering Technologies*, 58-63.
- Bruce S. Alpert, M. Q. (2014). Oscillometric blood pressure: A review for clinicians. *Journal of the American Society of Hypertension*, 930-38.
- Cameron, N. (2023). *ESP32 Microcontroller*. Apress, Berkeley, CA.
- Chauhan, M. (2023). Emerging Trends in Telemedicine and Remote Patient Monitoring: Improving Access to Healthcare Services. *International Research Journal of Basic and Clinical Studies*, 2(4), 53-62.
- Cavero-Redondo, I., Saz-Lara, A., Sequi-Dominguez, I., Gómez-Guijarro, M. D., Ruiz-Grao, M. C., Martínez-Vizcaino, V., & Alvarez-Bueno, C. (2021). Comparative effect of eHealth interventions on hypertension management-related outcomes: a network meta-analysis. *International Journal of Nursing Studies*, 124, 104085.
- Choi, Y. Y. C., Fineberg, M., & Kassavou, A. (2023). Effectiveness of Remote Interventions to Improve Medication Adherence in Patients after Stroke: A Systematic Literature Review and Meta-Analysis. *Behavioral Sciences*, 13(3), 246.

- Clinic, C. (2022). *Diseases & Conditions*. (Cleveland Clinic) Retrieved April 17, 2024, from <https://my.clevelandclinic.org/health/diseases/6530-pulmonary-hypertension-ph>.
- Desnanjaya, I. G. M. N., & Nugraha, I. M. A. (2024). Real-time monitoring system for blood pressure monitoring based on Internet of Things. *Indonesian Journal of Electrical Engineering and Computer Science*, 35(1), 62-69.
- Dresden, D. (2021). *2022 Omron blood pressure monitors: What to know*. Brighton: Medical News Today.
- Electronicwings. (2024). *Sensors and Modules*. Retrieved from [www.electronicwings.com](http://www.electronicwings.com): <https://www.electronicwings.com/sensors-modules/ssd1306-oled-display>.
- Elena Chung, G. C. (2013). Non-invasive continuous blood pressure monitoring. *Springer*, 91-101.
- Empowerlaptop. (2022). <https://www.empowerlaptop.com/p/uc15ab-128-std/>. Retrieved from [www.empowerlaptop.com](http://www.empowerlaptop.com): <https://www.empowerlaptop.com/p/uc15ab-128-std>.
- Fujiwara, N. A. (2024). Future of hypertension management through mobile applications. *Hypertension Research*, 1087–1089.
- Garovic, V. D., Dechend, R., Easterling, T., Karumanchi, S. A., McMurtry, S. B., Magee, L. A., & August, P. (2022). Hypertension in pregnancy: Diagnosis, blood pressure goals, and pharmacotherapy: A scientific statement from the American Heart Association. *Hypertension*, 79(2), e21-e41.
- Geeksforgeeks. (2024). *Software engineering*. Retrieved from [www.geeksforgeeks.org](http://www.geeksforgeeks.org): Roger S. Pressman.
- Ghate, S. (2014). *slideshow*. Retrieved from [www.slideshare.net](http://www.slideshare.net): <https://www.slideshare.net/slideshow/3g-technology-32519162/32519162>.
- Guglielmo Imbriaco, A. M. (2020). Radial artery cannulation in intensive care unit patients. *SagePub*, 1-7.

- Hall, A. (2022). *Best Blood Pressure Monitors Of 2022*. Retrieved from <https://www.forbes.com/>: <https://www.forbes.com/health/healthy-aging/best-blood-pressure-monitors>.
- Ibrahim, M. M. (2019). The New (2018) European Hypertension Guidelines an overview & comments. *Annals of Clinical Hypertension*, 3(2), 39-42.
- ISO. (2024). *Home*. Retrieved from [www.iso.org](http://www.iso.org): <https://www.iso.org/home.html>
- Jones, K. B. (2022, August). *Blood Pressure Monitoring at Home*. Retrieved from [familydoctor.org](http://familydoctor.org): <https://familydoctor.org>.
- Kortum, P., & Peres, S. C. (2015). Evaluation of home health care devices: Remote usability assessment. *Journal of Medical Internet Research Human Factors*, 2(1), e4570.
- Kumar, N. K. M. (2015). A Content Analysis Of Smartphone-Based Applications For Hypertension Management. *Journal of the American Society of Hypertension*, 130–136.
- Lastminuteengineers. (2024). *Displays*. Retrieved from [lastminuteengineers.com](http://lastminuteengineers.com): <https://lastminuteengineers.com/oled-display-arduino-tutorial>.
- Li, C., Chang, Q., Zhang, J., & Chai, W. (2018). Effects of slow breathing rate on heart rate variability and arterial baroreflex sensitivity in essential hypertension. *Medicine*, 97(18), e0639.
- Linda, J., & Vorvirk, M. (2023). *Medical Encyclopedia*. Retrieved from [medlineplus.gov](http://medlineplus.gov): <https://medlineplus.gov/ency/article/002341.htm>.
- Liyanage-Don, N., Fung, D., Phillips, E., & Kronish, I. M. (2019). Implementing home blood pressure monitoring into clinical practice. *Current Hypertension Reports*, 21, 1-14.
- Lunyera, J., Kirenga, B., Stanifer, J. W., Kasozi, S., van der Molen, T., Katagira, W., & Kalyesubula, R. (2018). Geographic differences in the prevalence of hypertension in Uganda: Results of a national epidemiological study. *PloS One*, 13(8), e0201001.
- Makers. (2023). *Modules*. Retrieved from [makerselectronics.com](http://makerselectronics.com): <https://makerselectronics.com/product/max30102-heart-rate-and-pulse-oximeter-sensor>.

- Malasinghe, L. P., Ramzan, N., & Dahal, K. (2019). Remote patient monitoring: A comprehensive study. *Journal of Ambient Intelligence and Humanized Computing*, *10*, 57-76.
- Mayoclinic. (2024). *High blood pressure (hypertension)*. Retrieved from [www.mayoclinic.org: https://www.mayoclinic.org/diseases-conditions/high-blood-pressure/symptoms-causes/syc-20373410](https://www.mayoclinic.org/diseases-conditions/high-blood-pressure/symptoms-causes/syc-20373410).
- Mikroelectron. (2024). *Product*. Retrieved from [mikroelectron.com: https://mikroelectron.com/Product/V-KEL-GPS-Receiver-module-antenna-VK2828U7G5LF-TTL](https://mikroelectron.com/Product/V-KEL-GPS-Receiver-module-antenna-VK2828U7G5LF-TTL).
- Mordor Intelligence. (2024). *Home Blood Pressure Monitoring Devices Market Share*. Hyderabad: Mordor Intelligence.
- Muhangi, K. (2019). *Overview of Data Protection Regime in Uganda*. Kampa: Ktaadvocates.
- Mustapha, A., Ssekasanvu, J., Chen, I., Grabowski, M. K., Ssekubugu, R., Kigozi, G., & Post, W. S. (2022). Hypertension and socioeconomic status in south central Uganda: A population-based cohort study. *Global Heart*, *17*(1), 3.
- National Drug Authority. (2024). *Medical-devices*. Retrieved from [www.nda.or.ug: https://www.nda.or.ug/medical-devices](https://www.nda.or.ug).
- Natukwatsa, D., Wosu, A. C., Ndyomugenyi, D. B., Waibi, M., & Kajungu, D. (2021). An assessment of non-communicable disease mortality among adults in Eastern Uganda, 2010–2016. *Plos one*, *16*(3), e0248966.
- Noah, B., Keller, M. S., Mosadeghi, S., Stein, L., Johl, S., Delshad, S., & Spiegel, B. M. (2018). Impact of remote patient monitoring on clinical outcomes: An updated meta-analysis of randomized controlled trials. *NPJ Digital Medicine*, *1*(1), 20172.
- Okello, S., Muhihi, A., Mohamed, S. F., Ameh, S., Ochimana, C., Oluwasanu, A. O., & Danaei, G. (2020). Hypertension prevalence, awareness, treatment, and control and predicted 10-year CVD risk: A cross-sectional study of seven communities in East and West Africa (SevenCEWA). *BMC Public Health*, *20*, 1-13.

- Peng, G. G. (2010). The survey of GSM wireless communication system. *2010 International Conference on Computer and Information Application*, 121-124. Tianjin: IEEE.
- Peyroteo, M., Ferreira, I. A., Elvas, L. B., Ferreira, J. C., & Lapão, L. V. (2021). Remote monitoring systems for patients with chronic diseases in primary health care: Systematic review. *Journal of Medical Internet Research mHealth and uHealth*, 9(12), e28285.
- Pradeepa, H., Priya, C., Saravanan, G., Thenmozhi, R., & Srinivasan, C. (2023, November). Smart IoT Solutions for Personalized Health: MQTT-Based Blood Pressure Monitoring System. In *2023 7<sup>th</sup> International Conference on Electronics, Communication and Aerospace Technology*, 1369-1373.
- Pranob, M. (2022). *How to make the most of your Galaxy Watch 4 with a non-Samsung phone*. Retrieved from [www.xda-developers.com](https://www.xda-developers.com/how-to-use-samsung-galaxy-watch-4-with-non-samsung-phone): <https://www.xda-developers.com/how-to-use-samsung-galaxy-watch-4-with-non-samsung-phone>.
- Ruiz-Fernández, D., Marcos-Jorquera, D., Gilart-Iglesias, V., Vives-Boix, V., & Ramírez-Navarro, J. (2017). Empowerment of patients with hypertension through BPM, IoT and remote sensing. *Sensors*, 17(10), 2273.
- Rockethealth.africa. (2022). *Services*. Retrieved from [rocket health.Africa](https://rockethealth.africa/services/#care): <https://rockethealth.africa/services/#care>.
- Samson, M. (2024). *Hypertension*. Retrieved from [emedicine.medscape.com](https://emedicine.medscape.com/article/241381-overview?form=fpf): <https://emedicine.medscape.com/article/241381-overview?form=fpf>.
- Shin, G., Jarrahi, M. H., Fei, Y., Karami, A., Gafinowitz, N., Byun, A., & Lu, X. (2019). Wearable activity trackers, accuracy, adoption, acceptance and health impact: A systematic literature review. *Journal of Biomedical Informatics*, 93, 103153.
- Siddharthan, T., Kalyesubula, R., Morgan, B., Ermer, T., Rabin, T. L., Kayongo, A., & Knauf, F. (2021). The rural Uganda non-communicable disease (RUNCD) study: Prevalence and risk factors of self-reported NCDs from a cross-sectional survey. *BMC Public Health*, 21, 1-8.

- Trust, D. E. (2016). *Sphygmomanometers*. Retrieved from <http://www.dableducational.org:>  
[http://www.dableducational.org/sphygmomanometers/devices\\_2\\_sbpm.html](http://www.dableducational.org/sphygmomanometers/devices_2_sbpm.html).
- Uganda Ministry of Health. (2020). *Hospitals*. Retrieved from [www.health.go.ug:](http://www.health.go.ug:)  
<https://www.health.go.ug/hospitals/>
- Urrea, C., & Venegas, D. (2020). Automatized follow-up and alert system for patients with chronic hypertension. *Health Informatics Journal*, 26(4), 2625-2636.
- Wiegand, H. (1968). Kish, L.: Survey Sampling. John Wiley & Sons, Inc., New York, London 1965, IX + 643 S., 31 Abb., 56 Tab., Preis 83 s. *Biometrische Zeitschrift*, 88-89.
- World Health Organization. (2023). *News*. Retrieved from [www.who.int:](http://www.who.int:)  
<https://www.who.int/news/item/25-08-2021-more-than-700-million-people-with-untreated-hypertension>.
- Zhong, D., Yian, Z., Lanqing, W., Junhua, D., & Jiaxuan, H. (2020). Continuous blood pressure measurement platform: A wearable system based on multidimensional perception data. *IEEE Access*, 8, 10147-10158.

## APPENDICES

### Appendix 1: Sample Size Determination

Using Kish and Leslie's formula,

$$n = \frac{N \cdot Z^2 \cdot p \cdot (1-p)}{E^2 \cdot (N-1) + Z^2 \cdot p \cdot (1-p)}$$

#### For Hypertension Patients

Given:

N = 740 (for population size)

Z = 1.96 (for confidence level)

P = 0.5 (for maximum sample size)

E = 0.05 (for +/-5% margin of error)

Computing these values, n is approximately 253 sample size.

#### For Medical Practitioners

N = 29 (for population size)

Z = 1.96 (for confidence level)

P = 0.5 (for maximum sample size)

E = 0.05 (for +/-5% margin of error)

Computing these values, n is approximately 27 sample size.

## Appendix 2: Questionnaire to Medical Practitioners



**Project Title:** An enhanced IoT-based wristband for remote monitoring and early detection of hypertension complications in Uganda.

Dear Participant,

I am Nkoloogi Blasius, a master's degree student at The Nelson Mandela African Institution of Science and Technology (NM-AIST), Arusha, Tanzania. I invite you to participate in this survey.

The purpose of this study is to develop an enhanced IoT-based wristband for remote monitoring and early detection of hypertension complications in Uganda. The benefit of this study is to provide a tool that will assist hypertension patients in remote monitoring and early detection of their complications.

You have been identified as a potential key participant in this survey because of your role and experience in health services provision in Uganda. This survey will take about 5 to 10 minutes of your time. Your responses will be kept confidential in secured computer files and be used for medical research purposes.

### **Consent:**

I voluntarily accept to take part in this study.

Yes

No

**Section A: Demographic Information**

**1. What is your gender**

- Male                       Female

**2. What is your highest education level?**

- Primary Level Certificate
- Ordinary Level Certificate
- Advanced Level Certificate
- Diploma Level Certificate
- Advanced Diploma Level Certificate
- University Level Certificate
- Postgraduate Level Certificate
- Other (Please mention) .....

**Section B: Diagnosis of high blood pressure to patients**

**1. Are you a medical practitioner with Rocket Health in Uganda**

- True               False

If yes, which cadre of the healthcare provider are you?

- Specialist (Surgeon, Dentist, Radiologist, or Pediatrician)
- General Practitioner
- Nurse
- Midwife
- Laboratory Technologist
- Laboratory Technician
- Pharmacy Technician

Pharmacist

Other (Please mention) .....

**2. Have you diagnosed high blood pressure patients before?**

Yes  No

**3. What type of methods do you offer for high blood pressure testing?**

Home Blood Pressure Monitoring (self-testing)  Hospital testing  Both

**4. What challenges do you encounter with self-testing of blood pressure at home?**

Miss interpretation of results

Misplacement of records

Have no access to Blood Pressure machine.

Challenges operating Blood Pressure machines (batteries, Knowledge, etc.)

Other (Please mention) .....

**5. What challenges do you encounter with hospital testing of blood pressure?**

Long queues

Anxiety

High Bills

Long distances to hospitals

Other (Please mention) .....

**6. How often do you follow up on your high blood pressure patients?**

Daily

Weekly

Twice a Week

Monthly

Twice a Month

Almost after 2 Months

**7. Do patients track any records after doing self-testing of their blood pressure?**

- Always
- Sometimes
- Rarely
- Never

**8. How does the patient keep results after doing self-testing of blood pressure?**

- Smart Phone
- Diary / Notebook
- Do not record.

Other (Please mention) .....

**9. What challenges do you get when giving care to a high blood pressure patient?**

- Irregular communication with patients
- Lack of tracking for different patients
- Miss interpretation of results with self-testing methods
- Misplacement of records

Other (Please mention) .....

**10. What improvements would you suggest for the existing blood pressure measuring devices/methods?**

- Real-time notification to both doctor and patient in case of critical conditions measured
- Centralized database for measured records

Other (Please mention) .....

***Thank you for your valuable time!***

### Appendix 3: Questionnaire to Hypertension Patients



**Project Title:** An enhanced IoT-based wristband for remote monitoring and early detection of hypertension complications in Uganda.

Dear Participant,

I am Nkoloogi Blasius, a master's degree student at The Nelson Mandela African Institution of Science and Technology (NM-AIST), Arusha, Tanzania. I invite you to participate in this survey.

The purpose of this study is to develop an enhanced IoT-based wristband for remote monitoring and early detection of hypertension complications in Uganda. The benefit of this study is to provide a tool that will assist hypertension patients in remote monitoring and early detection of their complications.

You have been identified as a potential key participant in this survey because of your role and experience in using Rocket Health services in Uganda. This survey will take about 5 to 10 minutes of your time. Your responses will be kept confidential in secured computer files and be used for medical research purposes.

**Consent:**

I voluntarily accept to take part in this study.

Yes

No

## **Section A: Demographic Information**

**1. What is your gender**

- Male                       Female

**2. What is your age?**

- Below 18 years old  
 18-25 years old  
 26-39 years old  
 40-49 years old  
 50- 59 years old  
 60-69 years old  
 70-79 years old  
 80 and above

**3. What is your marital status?**

- Single, never married  
 Divorced  
 Married  
 Widowed  
 Separated

**4. What is your highest education level?**

- Primary Level Certificate  
 Ordinary Level Certificate  
 Advanced Level Certificate  
 Diploma Level Certificate  
 Advanced Diploma Level Certificate

University Level Certificate

Postgraduate Level Certificate

Other (Please mention) .....

**Section B: Diagnosis of high blood pressure**

**1. Have been diagnosed with a high blood pressure disease before?**

Yes

No

**2. You are getting chronic care with Rocket Health in Uganda**

Yes

No

**3. What type of methods do you use for high blood pressure testing?**

Home Blood Pressure Monitoring (self-testing)    Hospital testing    Both

**4. What challenges do you encounter with self-testing of blood pressure at home?**

Miss interpretation of results

Misplacement of records

Have no access to a Blood Pressure machine.

Challenges operating Blood Pressure machines (batteries, Knowledge, etc.)

Other (Please mention) .....

**5. What challenges do you encounter with hospital testing of blood pressure?**

Long queues

Anxiety

High Bills

Long distances to hospitals

Other (Please mention) .....

**6. How often do you communicate with your doctor to discuss results after doing self-testing of blood pressure?**

Daily

Weekly

Twice a week

Almost after 2 months

Other (Please mention) .....

**7. Do you track any records after doing self-testing of your blood pressure?**

Always

Sometimes

Rarely

Never

**8. How do you keep results after doing self-testing of blood pressure?**

Smart Phone

Diary / Notebook

Do not record.

Other (Please mention) .....

**9. What improvements would you suggest for the existing blood pressure measuring devices/methods?**

Real-time notification to both doctor and patient in case of critical conditions measured

Centralized database for measured records

Other (Please mention) .....

***Thank you for your valuable time!***

## Appendix 4: Questionnaire for System Validation



**Title of Study:** An enhanced IoT-based Wristband for remote monitoring and early detection of hypertension complications in Uganda

Dear Participant,

I am Nkoloogi Blasius, a master's degree student at The Nelson Mandela African Institution of Science and Technology (NM-AIST), Arusha, Tanzania. I invite you to participate in this survey.

The purpose of this study was to develop an enhanced IoT-based wristband for remote monitoring and early detection of hypertension complications in Uganda. The benefit of this study is to provide a tool that will assist hypertension patients in remote monitoring and early detection of their complications.

You have been identified as a potential key participant in this survey because of your role and experience in health services provision in Uganda. This survey will take about 5 to 10 minutes of your time. Your responses will be kept confidential in secured computer files and be used for medical research purposes.

You are requested to evaluate the developed system.

### Consent:

I voluntarily take part in this survey.

Yes

No

- 1. How easy was it to use the wristband system?**
  - Very easy
  - Somewhat easy
  - Neutral
  - Very difficult
  
- 2. How accurate were the readings provided by the wristband system?**
  - Very accurate
  - Somewhat accurate
  - Neutral
  - Somewhat inaccurate
  - Very inaccurate
  
- 3. How reliable was the wristband system in monitoring hypertension?**
  - Very reliable
  - Somewhat reliable
  - Neutral
  - Somewhat unreliable
  - Very unreliable
  
- 4. How useful was the information provided by the wristband system in managing hypertension?**
  - Very useful
  - Somewhat useful
  - Neutral
  - Somewhat not useful
  - Not useful at all
  
- 5. How satisfied were you with the overall performance of the wristband system?**
  - Very satisfied
  - Somewhat satisfied
  - Neutral
  - Somewhat dissatisfied
  - Very dissatisfied

**Thank you for your valuable time!**

## Appendix 5: Codes for Final Hardware Prototype

```
#include <SPI.h>

#include <Wire.h>

#include <Adafruit_GFX.h>

#include <Adafruit_SSD1306.h>

#include <OneWire.h>

#include <DallasTemperature.h>

#include <TinyGPS.h>

#include <SoftwareSerial.h>

#include "MAX30102.h"

#include "spo2_algorithm.h"

SoftwareSerial sim5320Serial(7, 8); // RX, TX for 3G/4G module object

// Variables to store values to be uploaded

float temp = 25.0;

int diastolic = 34;

int systolic = 43;

int heart_rate = 21;

int oxygen_saturation = 95;

String longitude = "32.5974225";

String latitude = "0.3577040";

int respiratory_rate = 23;

// Variables to store MAX30102 values

int32_t bufferLength; //data length
```

```

int32_t spo2;      //SPO2 value

int8_t validSPO2; //indicator to show if the SPO2 calculation is valid

int32_t heartRate; //heart rate value

int8_t validHeartRate; //indicator to show if the heart rate calculation is valid

String number1 = "+256704756496"; // Patient's number

String number2 = "+256757886712"; // Doctor1's number

String number3 = "+256700276993"; // Next of kin's number

int bp_sys_max = 140; // maximum systolic value for conditioning

int bp_dias_max = 90; // maximum diastolic value for conditioning

String id = "00:00:5e:00:53:af"; //MAC address for wristband

const char apn[] = "internet"; //setting the constant apn as "internet"

const int oneWireBus = 4; //pin for temp sensor

#define SCREEN_WIDTH 128 // OLED display width, in pixels

#define SCREEN_HEIGHT 32 // OLED display height, in pixels

#define OLED_RESET -1 // Reset pin # (or -1 if sharing Arduino reset pin)

#define SCREEN_ADDRESS 0x3C ///< See datasheet for Address; 0x3D for 128x64, 0x3C
for 128x32

#define setLED 5

#define readyLED 15

// #define setLED 32

#define dangerLED 33

#define BUZZZER_PIN 18 // ESP32 pin GIOP18 connected to piezo buzzer

#define MAX_BRIGHTNESS 255

int16_t irBuffer[100]; //infrared LED sensor data

```

```

uint16_t redBuffer[100]; //red LED sensor data

#else

uint32_t irBuffer[100]; //infrared LED sensor data

uint32_t redBuffer[100]; //red LED sensor data

#endif

Adafruit_SSD1306      display(SCREEN_WIDTH,      SCREEN_HEIGHT,      &Wire,
OLED_RESET);

MAX30105 particleSensor;

TinyGPS gps;

OneWire oneWire(oneWireBus);

DallasTemperature sensors(&oneWire);

byte tester[] = { 0xF7, 0x00, 0x00, 0x00, 0x00, 0x00 };

byte data[] = { 0xFD, 0x00, 0x00, 0x00, 0x00, 0x00 }; // for receiving data

byte calib[] = { 0xFE, 0x7A, 0x47, 0x60, 0x00, 0x00 }; // Calibration buffer.

int l_val = 0; //low pressure value , diastolic blood pressure

int h_val = 0; //High pressure value , systolic blood pressure

int hrt_val = 0; // Heart rate value, pulse rate

int old_l_val = 0;

int old_h_val = 0;

int old_hrt_val = 0;

bool start_seperation = false;

bool start_ = false;

String hr = "";

String Ohr = "";

String bp = "";

```

```

String Obp = "";

String retn = "";

int counter = 0;

long timer = 0;    // for initialisation timing

long stimer = 0;   // spo2 reading timer

long upload_timer = 0; // data upload timer

long temp_timer = 0;

long gpsTimer = 0;

bool waiting = true; // boolean to wait for setup

bool upload = false; // boolean to trigger remote upload

int critical = 0;    // boolean for sending sms while in critical conditioning

String address = "00:00:5e:00:53:af"; //MAC

void setup() {

    Serial.begin(115200);

    sim5320Serial.begin(4800);

    Serial2.begin(115200);

    // Reset SIM5320 module

    pinMode(6, OUTPUT);

    digitalWrite(6, HIGH);

    delay(100);

    digitalWrite(6, LOW);

    delay(1000);

    // Configure SIM5320 module

    sim5320Serial.print("AT+CPIN=\"1234\"\r\n"); // SIM PIN

```

```

delay(2000);

sim5320Serial.print("AT+SAPBR=3,1,\"APN\", \"internet\"\r\n");

delay(1000);

sim5320Serial.print("AT+SAPBR=1,1\r\n");

delay(10000);

sim5320Serial.print("AT+SAPBR=2,1\r\n");

delay(1000);

sim5320Serial.print("AT+HTTPIPINIT\r\n");

delay(1000);

pinMode(setLED, OUTPUT);

pinMode(readyLED, OUTPUT);

pinMode(BUZZZER_PIN, OUTPUT);

pinMode(dangerLED, OUTPUT);

// pinMode(uint8_t pin, uint8_t mode)

digitalWrite(setLED, LOW);

digitalWrite(readyLED, LOW);

while (!Serial || !Serial1) {

    ;

}

if (!display.begin(SSD1306_SWITCHCAPVCC, SCREEN_ADDRESS)) {

    for (;;)

        ;

}

```

```

// Clear the buffer

display.clearDisplay();

display.setTextSize(2);

display.setTextColor(SSD1306_WHITE);

display.setCursor(32, 10);

display.println(F("PLESA"));

display.display();

delay(3000);

display.clearDisplay();

display.setTextSize(2);

display.setTextColor(SSD1306_WHITE);

display.setCursor(0, 5);

display.println(F("BP :"));

display.setCursor(0, 20);

display.println(F("HRT:"));

display.display();

// Initialize sensor

if (!particleSensor.begin(Wire, I2C_SPEED_FAST))

{

    while (1)

        ;

}

byte ledBrightness = 60;

```

```

byte sampleAverage = 4;

byte ledMode = 2;

byte sampleRate = 100;

int pulseWidth = 411;

int adcRange = 4096;

delay(1000);

timer = millis();

stimer = millis();

upload_timer = millis();

temp_timer = millis();

gpsTimer = millis();

sensors.begin();

//calibrate();

}

void loop() {

if (millis() - timer > 60000) {

    start_ = true;

    timer = millis();

}

if (start_) {

    upload = true; // enable remote upload

```

```

digitalWrite(readyLED, HIGH);

waiting = false;

bp_values();

delay(1000);

if (h_val == 0 || h_val == 255) {

    bp += "NULL";

    hr += "NULL";

    upload = false; // do not upload if the value is null

} else {

    upload = true;

    bp += ((String)h_val + "/" + (String)l_val);

    hr += (String)hrt_val;

    if (h_val >= bp_sys_max && l_val >= bp_dias_max) {

        critical++;

        for (int i = 0; i < 3; i++) {

            digitalWrite(dangerLED, HIGH);

            delay(250);

            digitalWrite(dangerLED, LOW);

            delay(250);

        }

        alarm_();

    }

    if (critical == 1) { //condition to send SMS if hypertension detected

        sendSMS(number1);

```

```

    delay(5000); //tweek this delay for multiple number sending, was 3000 or 3 seconds

    sendSMS(number2);

    delay(5000);

    sendSMS(number3); //send sms to patient

    critical = false;

}

critical = 2;

}

}

String end1 = " mmHg";

String end2 = " bpm";

display.setTextSize(1);

display.setTextColor(SSD1306_BLACK);

display.setCursor(50, 8);

display.println(String(Obp));

display.setCursor(50, 24);

display.println(String(Ohr));

display.display();

Obp = "";

Ohr = "";

hr = hr + end2;

bp = bp + end1;

```

```
display.setTextSize(1);  
display.setTextColor(SSD1306_WHITE);  
display.setCursor(50, 8);  
display.println(String(bp));  
display.setCursor(50, 24);  
display.println(String(hr));  
display.display();  
delay(1000);
```

```
Ohr = Ohr + hr + end2;  
Obp = Obp + bp + end1;  
hr = "";  
bp = "";  
retn = "";  
  
//conditions here  
}
```

```
if (waiting) {  
    display.setTextColor(SSD1306_WHITE);  
    display.setCursor(50, 5);  
    display.println(F("_"));  
    display.setCursor(50, 16);  
    display.println(F("_"));  
    display.display();  
    digitalWrite(setLED, HIGH);
```

```

delay(500);

display.setTextColor(SSD1306_BLACK);

display.setCursor(50, 5);

display.println("_");

display.setCursor(50, 16);

display.println("_");

display.display();

digitalWrite(setLED, LOW);

delay(500);
}

if (millis() - stimer > 10000) {

  int s = getSpo2();

  if (s > 89) {

    oxygen_saturation = s;

  } else {

    stimer = millis();

  }

}

// GET TEMPERATURE

if (millis() - temp_timer > 15000) {

  getTemp();

  temp_timer = millis();

}

//UPLOAD TO REMOTE SERVER

if (millis() - upload_timer > 20000) { //tweek this sending time , was 60000, reduce

```

```

if (upload) {
    if (waitNetwork()) {
        // Construct HTTP request
String request = "AT+HTTTPARA=\"URL\", \"https://wristband.tmcg.dev/post.php\"\\r\\n";
request += "AT+HTTTPARA=\"CONTENT\", \"application/x-www-form-urlencoded\"\\r\\n";
request += "AT+HTTPDATA=" + String(32 + request.length()) + ",5000\\r\\n";

request += "/api/device/" + address + "?" + "temperature=" + temp + "&diastolic=" + l_val +
"&systolic=" + h_val + "&heart_rate=" + heart_rate + "&oxygen_saturation=" +
oxygen_saturation + "&respiratory_rate=" + respiratory_rate + "&longitude=" + longitude +
"&latitude=" + latitude;

        String rtn = "";
request += "AT+HTTPACTION=1\\r\\n";

// Send HTTP request
sim5320Serial.print(request);

delay(5000);

// Check HTTP response
String response = "";

while (sim5320Serial.available()) {
    response += (char)sim5320Serial.read();
}

Serial.println(response);

    }
}

upload_timer = millis();

```

```

}

if (millis() - gpsTimer > 6000) {

    getLocation();

    gpsTimer = millis();

}

if (millis() - gpsTimer > 20000) {

    getLocation();

    gpsTimer = millis();

}

}

void bp_values() {

    Serial2.write(data, sizeof(data));

    while (!Serial2.available())

        ;

    if (Serial2.available()) {

        while (Serial2.available()) {

            byte a = Serial2.read();

            if (start_seperation) {

                if (counter == 0) {

                    h_val = a;

                }

                if (counter == 1) {

                    l_val = a;

                }

            }

        }

    }

}

```



## Appendix 6: Automatic Report Generation

The screenshot displays a web application interface for patient monitoring. The browser address bar shows `https://wristband.tmcg.dev/patients/3`. The interface is divided into a sidebar on the left and a main content area on the right.

**Sidebar:**

- SPo2 (%):** 98. A **VIEW LOCATION** button is present.
- Devices:** 00:00:5e:00:53:af. **DETACH** and **ADD** buttons are available.
- Doctors:** Blasius. **DETACH** and **ADD** buttons are available.

**Main Content Area:**

A **CSV** button and a **Search:** input field are located at the top. Below is a table of sensor readings:

Blood Pressure (mmHg)	Heart Rate (bpm)	SPo2 (%)	Temp (°C)	Device	Reading Time
125/72	77	98	37	00:00:5e:00:53:af	2023-09-04T19:04:29.000000Z
130/74	79	98	37	00:00:5e:00:53:af	2023-09-04T19:02:42.000000Z
127/72	88	100	37	00:00:5e:00:53:af	2023-09-04T19:00:57.000000Z
133/74	74	99	37	00:00:5e:00:53:af	2023-09-04T18:58:36.000000Z
116/69	76	90	37	00:00:5e:00:53:af	2023-09-04T18:56:11.000000Z
119/70	78	90	37	00:00:5e:00:53:af	2023-09-04T18:54:26.000000Z
117/70	70	95	38	00:00:5e:00:53:af	2023-09-04T18:48:17.000000Z
138/75	70	92	38	00:00:5e:00:53:af	2023-09-04T18:46:30.000000Z

The Windows taskbar at the bottom shows various application icons, including File Explorer, Calculator, and Patient - Ples...

## Appendix 7: Photo of a Final Prototype

