

An overview of pipeline leak detection and location systems

Lawrence Boaz, Shubi Kaijage and Ramadhani Sinde

Nelson Mandela African Institution of Science and Technology (NM-AIST), School of Computational and Communication Science and Engineering
Arusha, Tanzania

boazl@nm-aist.ac.tz, shubi.kaijage@nm-aist.ac.tz, ramadhani.sinde@nm-aist.ac.tz

Abstract: Leak detection in transmission pipelines is crucially important for safe operation. Delay in detecting leaks leads to loss of property and human life in fire hazards and loss of valuable material. Leaking of methane and hydrocarbon gas causes negative impacts on the eco system such as global warming and air pollution. Pipeline leak detection systems play a key role in minimization of the probability of occurrence of leaks and hence their impacts. Today there are many available technologies in the domain of leak detection. This paper provides an overview on external and internal leak detection and location systems and a summary of comparison regarding performance of each system.

IndexTerms: Leak detection; Leak location; Transportation pipeline; Sound Pressure Level (SPL)

I. INTRODUCTION

Gas and Oil pipeline networks are the most economic and safest mode of transporting these energy sources. As a means of transportation, pipelines have to fulfill high demands of safety, reliability and efficiency [1]. If properly maintained, pipelines can last indefinitely without leaks. Most significant leaks that do occur are caused by damage from nearby excavation equipment, therefore it is critical to call authorities prior to excavation to assure that there are no buried pipelines around. If a pipeline is not properly maintained, it can begin to slowly corrode, particularly at construction joints, low points where moisture collects, or locations with imperfections in the pipe. However, these defects can be identified by inspection tools such as Cathodic Protection (CP) and be corrected before they progress to a leaking stage. Other reasons for leaks include accidents, terrorism, earth movement and sabotage.

The primary purpose of leak detection systems (LDS) is to assist pipeline controllers in detecting and localizing leaks [2]. LDS provide an alarm and display other related data to the pipeline controllers in order to assist in decision making. Pipeline leak detection systems are also beneficial because they can enhance productivity and system reliability thanks to reduced downtime and pipeline inspection time. LDSs are therefore an important aspect in ensuring optimal functioning and maintenance of pipeline networks.

II. LEAK DETECTION AND LOCATION TECHNOLOGY

Leak detection methods fall into two groups; non-continuous (line patrols) and continuous methods. Examples for non-continuous methods are: inspection by helicopter, smart pigging and trained dogs. Continuous methods is also further subcategorized into two groups namely internally based

(inferential) also known as Computational Pipeline Monitoring (CPM) and externally based (direct) leak detection systems [1] [3]. Externally based methods detect leaking product outside the pipeline while internally based systems utilize field instrumentation (e.g. for flow, pressure and fluid temperature) to monitor internal pipeline parameters. These pipeline parameters are subsequently used for inferring a leak. The method of leak detection selected for a pipeline is dependent on a variety of factors including pipeline characteristics, product characteristics, instrumentation and communications capabilities, and economics. Pipeline systems vary widely in their physical characteristics and operational functions, and neither external nor internal method is universally applicable or possesses all the features and functionality required for perfect leak detection performance [4]. However the chosen leak detection system should have the following performance criteria; sensitivity, reliability, accuracy and robustness. Table 1, shows a summary of pipeline leak detection systems.

TABLE I
LEAK DETECTION AND LOCATION SYSTEMS

Non continuous	Continuous	
Inspection by helicopter	External	Internal
Smart pigging	Fibre optic cable	Pressure point analysis
Trained dogs	Acoustic sensor	Mass balance method
	Sensor hose	Statistical system
	Video monitoring	RTTM and E-RTTM system

III. CONTINUOUS EXTERNAL SYSTEMS

Fiber Optic Cable

Fig. 1 describes fiber optic cable installed along the pipeline take temperature measurements over the entire pipeline length. The substances to be measured come into contact with the cable when a leak occurs, as a result changes the temperature of the cable. Leakages from pipeline introduce local temperature anomalies in the vicinity of the pipeline. Depending on the type of substance transported through the pipeline, it may be either a local warming (heating systems) or cooling (gas pipeline) [5]. For optimized transport of oil through pipelines, the oil is warmed up and in the case of leakage the surrounding soil temperature increases accordingly. On the other hand, leakages from pressurized gas pipelines introduces a temperature cooling due to

gas expansion and the associated temperature drop, the so-called Joule Thomson effect. The distributed fiber-optical temperature-sensing technique offers the possibility to measure temperature along the pipeline [5].

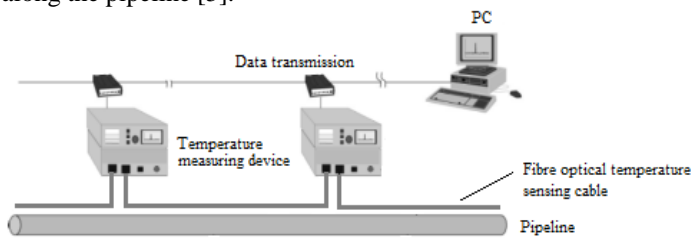

Fig.1. Fiber optic cable system [6]

This method provides accurate leakage detection and location, the major limitation is the limited length of cable and the system can no longer work if the cable is terminated.

Acoustic systems

Leak detection in pipelines using acoustic emissions technology is based on the principle that escaping liquid creates an acoustic signal (sound) as it passes through a perforation in the pipe [7]. When a leak occurs, the resulting frequency acoustic signal is detected and analyzed by system processors. The received signal is stronger near the leak site hence pin pointing the location of the leaking points. The sound produced by escaping gas is in the range of 25 kHz to 70 kHz ultrasound in most industrial detector models [8]. Acoustic sensing can be applied externally to buried pipelines by using steel rods driven into the ground to conduct the sound to a sensor mounted on the rod. The rods are inserted at intervals along the pipeline.

The pressure amplitudes of sound waves are commonly measured on a logarithmic scale (dB), called Sound Pressure Level (SPL) [8], given as (1)

$$SPL = 20 \log \left(\frac{P}{P_0} \right) \quad (1)$$

where P_0 is the pressure amplitude of a reference sound.

Sound Pressure Level is proportional to the power generated by the gas upon expansion, expressed as (2)

$$SPL \propto \log \left(\frac{RT}{M} \right) \quad (2)$$

where M is the mass flow rate of the jetting gas, T is gas temperature at the orifice, M is the molecular weight, and R is the gas constant.

This method has the advantages of high detection and localization accuracy but the system require large number of sensors for longer pipelines.

Sensor hoses

Fig. 2 depicts a sensor hose system; a device for detecting a medium includes a sensor hose to be laid at a medium to be detected. A material is disposed at least in the vicinity of the sensor hose. The material reacts when in contact with the medium to produce a substance being capable of diffusion and being detectable [9].

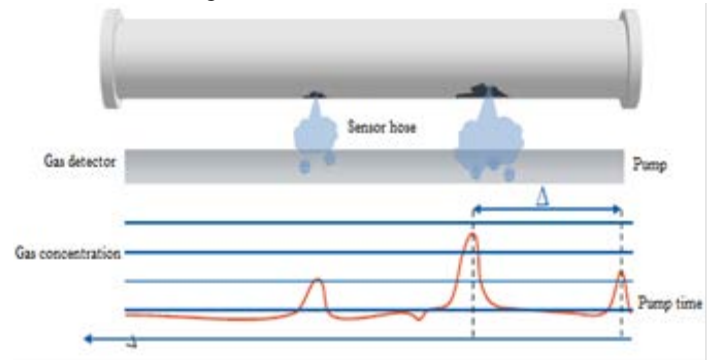

Fig. 2. Sensor hose system [9]

The system is capable of detecting small leaks, but it is useful for short pipelines. The position of the cable must be selected according to the medium.

Video monitoring

Pipeline video inspection is a form of telepresence used to visually inspect the interiors of pipelines. A common application is to determine the condition of small diameter sewer lines and household connection pipes. Closed circuit television (CCTV) has recently been used for sewer inspections and with grouting apparatus for making repairs. With CCTV, location of leaks, points of infiltrations, paved-over manholes, pipeline breaks, and lost articles such as rings or other valuables can be accomplished without the disadvantages accompanying the digging up of the pipeline [10].

IV. CONTINUOUS INTERNAL SYSTEMS

Pressure point analysis

The pressure point analysis leak detection method is based on the statistical properties of a series of pressure or velocity pipeline measurements at one point being different before and after a leak occurs [11]. A leak changes the hydraulics of the pipeline, and therefore changes the pressure or flow readings. The method detects leaks by monitoring pipeline pressure at a single point along the line and comparing it against a running statistical trend constructed from previous pressure measurements. The pressure wave source spreads out from the leak point to the leak upstream and downstream ends. Taking the pressure before the leak as the reference criterion, the wave generated by such a leak is called the negative pressure wave. When the negative pressure wave reaches the pipeline terminal end, it will cause the drop of first the station inlet pressure and then the station outlet pressure. Based on pressure difference that pressure sensors on both sides

detect, pipeline length and negative pressure wave velocity, the leak point can be determined [12].

Pressure point analysis can detect small leaks which cannot be detected by other methods. However, it is difficult for this method to localize leak points [7].

Mass Balance Method

Mass or Volume balance are in effect the same technique based on the principle of conservation of mass. The principle states that a fluid that enters the pipe section either remains in the pipe section or leaves the pipe section [13]. For a normal cylindrical pipeline the flow entering and leaving the pipe can be metered. The mass of fluid in the pipe section can be estimated from the pipe dimensions and measurements of state variables such as pressure and temperature. A leak is identified when less fluid leaves the pipe than is expected from the measurements of input flow and estimates of the pipe contents.

Although the principle of mass balance method is simple, this method is very sensitive to arbitrary disturbances and dynamics of the pipeline, which may lead to false detection issues [7].

Statistical Systems

Statistical Leak Detection Systems use methods and processes from decision theory. This leads to the opportunity to optimize the leak decision if some statistical assumptions hold. The hypothesis-test for leak detection based on the uncompensated mass balance, uses either a single measurement, or multiple measurements made at different times. To assign a single measurements (Δm) to H_0 and H_1 hypothesis, an alarm limit γ is defined [14]. The test defined as (3)

$$\Delta \begin{cases} \leq \gamma \rightarrow H_0 & \text{No leak} \\ > \gamma \rightarrow H_1 & \text{Leak} \end{cases} \quad (3)$$

RTTM based system

RTTM stands for Real-Time Transient Model, detect leakage in the pipeline using mathematical models based on physical laws such as conservation of mass, conservation of momentum and conservation of energy. RTTM methods can be seen as an enhancement of balancing methods as they additionally use the conservation principle of momentum and energy. The method calculate mass flow, pressure, density and temperature at every point along the pipeline in real-time with the help of mathematical algorithms [15]. RTTM LDS can easily model steady-state and transient flow in a pipeline. Using RTTM technology, leaks can be detected during steady-state and transient conditions (mostly gas pipeline).

The modern RTTM based systems calculate the flow in the pipeline from the pressure and temperature at the inlet and outlet as can be seen from Fig. 3. This calculated flow is then compared to the measured flow (from a flow meter at inlet and outlet). The difference between calculated and measured values for the inlet (or for the outlet) is around zero. For example, the flow changes, as does the pressure; but the difference between

calculated and measured flow will not change. Transients are present along the pipeline, yet the system is not affected by them. The difference in calculated and measured flow only appears when there is a leak. In this case, the pressure (and therefore the calculated flow) will shift due to the leak, while the measured flow remains constant. Such a difference is much easier to identify and is more reliable as an indicator. RTTM involves the computer simulation of pipeline conditions using advanced fluid mechanics and hydraulic modeling.

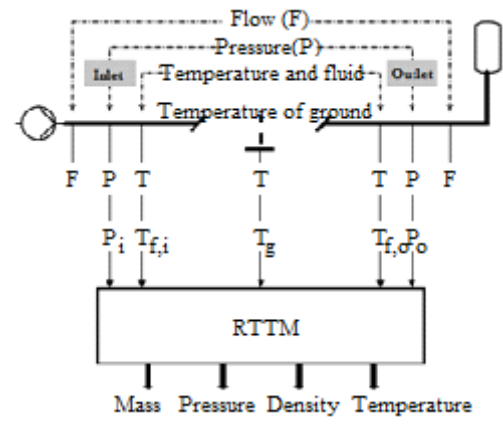

Fig. 3. RTTM System [14]

Fig. 4 exhibits an Extended-Real Time Transient Model (E-RTTM) have unique leak signature analysis feature which differentiate from RTTM [14]. E-RTTM is able to monitor pipeline in pumping conditions and in shut-in conditions. E-RTTM uses leak signature analysis, which executes after the pipeline observer. In this second stage residuals are analysed for leak signatures.

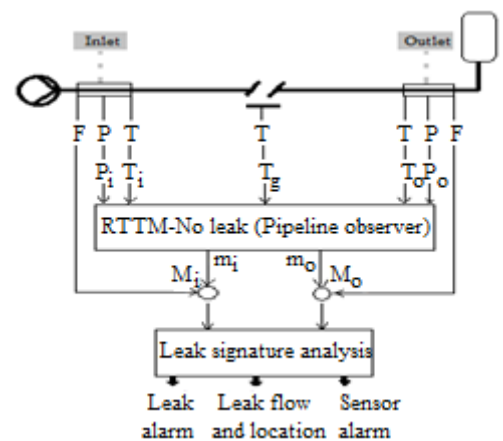

Fig. 4. E-RTTM System [14]

The distinct disadvantages of this method are the costs associated with implementing RTTM and the complexity of the system as it requires numerous instruments and extensive controller training and system maintenance.

Other methods employed for pipeline leak detection and location include the following:

Magnetic induction method

Magnetic Induction (MI) method utilize sensors both inside and outside the pipelines. Sensors which are inside measure pressure, velocity of fluid transported and acoustic vibrations caused by the leakages and that outside measure the temperature, humidity, and properties of the soil around the underground pipelines. The outside sensors provide high granularity for leakage detection and localization. Sensors inside pipeline are equipped with magnetic induction transceivers to communicate with the sensors buried along the pipeline.

Magnetic induction communication is achieved with the use of a coil of wire, as shown in Fig. 5. Those coils can be wound on the pipeline. The signal in the transmitter coil is modulated by a sinusoidal current, which produces a time varying magnetic field in the near field of the transmitter. The time varying magnetic field induces another sinusoidal current in the receiver, which accomplishes the communication [16].

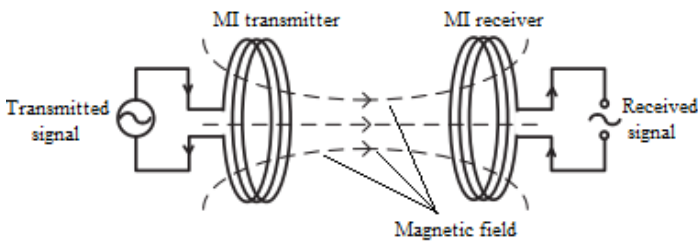

Fig. 5. MI communications [16]

Although MI systems provide both accurate real-time leakage detection and localization results in harsh underground environments but requires numerous number of sensors for its performance and hence high implementation cost.

Ground Penetration Radar

Ground Penetration Radar (GPR) can be used for pipeline leak detection [16] [17], however this system is not suitable for long pipeline and there is a challenge for clay soils where iron pipe corrosion products can hide cast iron pipes from the GPR. This occurs because corrosion products in the soil increase radio frequency (RF) signal attenuation and reduce reflection [18].

V. SYSTEM PERFORMANCE COMPARISON

The performance level of a leak detection and location system can be established by number of attributes. Some of the criteria that are usually used to evaluate the performance are given in Table 2 below [19]. The study shows that there is no method which is rated good for all the attributes [4], but in practice the performance of each method varies considerably depending on the vendors, pipeline operating conditions and quality of the hardware or instrumentation system available.

TABLE 2
COMPARISON ATTRIBUTES OF LEAK DETECTION AND LOCATION TECHNIQUES

METHOD	FEATURES						
	Easy usage	Easy retrofitting	Leak localization	Leak size estimate	Detection speed	False alarm redundancy	Cost
Inspection by helicopter	Yes	-	Yes	Yes	-	-	High
Smart piggings	Yes	No	Yes	Yes	Fast	-	High
Trained dogs	Yes	-	Yes	Yes	-	-	Low
Fibre optic cable	Yes	No	Yes	Yes	Fast	High	High
Acoustic sensor	Yes	Yes	Yes	Yes	Fast	High	Medium
Sensor hose	Yes	No	Yes	Yes	Fast	Medium	Low
Video monitoring	Yes	Yes	Yes	Yes	Fast	High	Medium
Pressure point analysis	Yes	Yes	No	No	Fast	Low	Low
Mass balance method	Yes	Yes	No	Yes	Fast	Low	Low
Statistical system	Yes	Yes	Yes	Yes	Fast	Medium	Medium
RTM and E-RTM system	No	Yes	Yes	Yes	Fast	High	High

VI. CONCLUSION

Leak Detection and Location in pipeline networks is a challenging research area involving rigorous testing and validation. Preceding the installation of LDSs environmental assessment must be conducted to determine whether environmental conditions such as air, land, water, energy and others may offset the functionality of the system [1] [2].

From the overview, external leak detection methods are able to detect very small leaks but the methods are rather time consuming, on the other hand pressure monitoring methods are able to very rapidly detect large leaks. Considering the limitation of continuous LDSs i.e., both internal and external LDSs it is worthwhile installing two parallel functioning LDSs for better results.

FUTURE WORK

Our investigation covered the initial stages of determining different industrial applicable leak detection and location systems, there are many technical problems to be addressed before an effective leak detection device can be produced. The next stage is to develop a real-time continuous gas pipeline monitoring system that will bring good result for both small and large leak size detection.

ACKNOWLEDGMENT

Our sincere acknowledgment to The Nelson Mandela African Institution of Science and Technology (NM-AIST) for facilitating this research work. Sincere gratitude to Songas Limited for their support throughout the course of this study, to mention a few Dr. Malcolm Taylor, Eng. John Runyoro, Elson Mushi and all people involved for their positive support.

REFERENCES

1. Technical Review of Leak Detection Technologies, vol. I: Crude Oil Transmission Pipelines, Technical Report, Alaska Department of Environmental Conservation, 1999.
2. Lopes dos Santos, P., et al., An LPV modeling and identification approach to leakage detection in high pressure natural gas transportation networks. *Control Systems Technology*, IEEE Transactions on, 2011. 19(1): p. 77-92.
3. Jawhar, I., N. Mohamed, and K. Shuaib. A framework for pipeline infrastructure monitoring using wireless sensor networks. in *Wireless Telecommunications Symposium*, 2007. WTS 2007. 2007. IEEE.
4. Muhlbauer, W.K., Pipeline risk management manual: ideas, techniques, and resources. 2004: Gulf Professional Publishing.
5. Nikles, M., et al. Leakage detection using fiber optics distributed temperature monitoring. in *Smart Structures and Materials*. 2004. International Society for Optics and Photonics.
6. Grosswig, S., et al. Pipeline leakage detection using distributed fibre optical temperature sensing. in *Bruges, Belgium-Deadline Past*. 2005. International Society for Optics and Photonics.
7. Wan, J., et al., Hierarchical leak detection and localization method in natural gas pipeline monitoring sensor networks. *Sensors*, 2011. 12(1): p. 189-214.
8. Naranjo, E. and S. Baliga, Expanding the Use of Ultrasonic Gas Leak Detectors: A Review of Gas Release Characteristics for Adequate Detection. *International Gases & Instrumentation*, 2009. 3(6): p. 24-29.
9. Issel, W., P. Jax, and W. Leuker, Device having a diffusion sensor hose for detecting a leak. 1993, Google Patents.
10. Fish, H.D. and K.H. Kalberer, METHOD AND APPARATUS FOR PIPELINE INSPECTION. 1975, US Patent 3,885,091.
11. bin Md Akib, A., N. bin Saad, and V. Asirvadam. Pressure point analysis for early detection system. in *Signal Processing and its Applications (CSPA)*, 2011 IEEE 7th International Colloquium on. 2011. IEEE.
12. Ma, C., S. Yu, and J. Huo. Negative pressure wave-low testing gas pipeline leak based on wavelet transform. in *Computer, Mechatronics, Control and Electronic Engineering (CMCE)*, 2010 International Conference on. 2010. IEEE.
13. Martins, J.C. and P. Selegim, Assessment of the performance of acoustic and mass balance methods for leak detection in pipelines for transporting liquids. *Journal of Fluids Engineering*, 2010. 132(1): p. 011401.
14. Geiger, Ing Gerhard. "Principles of leak detection." 2012-12-10. <http://www.krohne.com/leakdetection.html>.
15. Geiger, G., T. Werner, and D. Matko. Leak Detection and Locating—A Survey. in *35th Annual PSIG Meeting*. 2003.
16. Sun, Z., et al., MISE-PIPE: Magnetic induction-based wireless sensor networks for underground pipeline monitoring. *Ad Hoc Networks*, 2011. 9(3): p. 218-227.
17. Crocco, L., Prisco, G., Soldovieri, F., Cassidy, N.J., 2009. Early-stage leaking pipes GPR monitoring via microwave tomographic inversion. *Journal of Applied Geophysics* 67: p. 270–277.
18. Pennock, S. R., et al. (2010). Effects of iron pipe corrosion on GPR detection. *Ground Penetrating Radar (GPR)*, 2010 13th International Conference on, IEEE.
19. Staord, M., Williams, N., 1996. Pipeline leak detection study. Tech. rep., Bechtel Limited.