

2014-09

# Natural dyes for solar cell application: uv-visible spectra and outdoor photovoltaic performance

Pamain, Adriano

Research Journal in Engineering and Applied Sciences

---

<http://dspace.nm-aist.ac.tz/handle/123456789/629>

*Provided with love from The Nelson Mandela African Institution of Science and Technology*

See discussions, stats, and author profiles for this publication at: <https://www.researchgate.net/publication/267041554>

# NATURAL DYES FOR SOLAR CELL APPLICATION: UV-VISIBLE SPECTRA AND OUTDOOR PHOTOVOLTAIC PERFORMANCE

Article in *Research Journal of Applied Sciences, Engineering and Technology* · September 2014

CITATIONS

3

READS

1,391

3 authors, including:



**Adriano Pamain**

Dodoma University

1 PUBLICATION 3 CITATIONS

[SEE PROFILE](#)



**Tatiana Pogrebnaya**

The Nelson Mandela African Institute of Science and Technology

50 PUBLICATIONS 99 CITATIONS

[SEE PROFILE](#)

Some of the authors of this publication are also working on these related projects:



We are working on dyes for solar cells application (theoretical computation) [View project](#)



Electronic and Vibrational Spectra of Natural Dyes Constituents for Solar Cell Application: DFT and TDDFT Study [View project](#)

## NATURAL DYES FOR SOLAR CELL APPLICATION: UV-VISIBLE SPECTRA AND OUTDOOR PHOTOVOLTAIC PERFORMANCE

Adriano Pamain, Tatiana Pogrebnaya, Cecil K. King'ondy

The Nelson Mandela African Institution of Science and Technology (NM-AIST),

Department of Materials, Energy, Sciences and Engineering.

PO Box 447, Arusha Tanzania.

Corresponding Author: Cecil K. King'ondy

### ABSTRACT

Successful conversion of visible light into electrical output was achieved by using four locally available natural dyes as wide band gap semiconductor sensitizers in Dye-sensitized solar cells. Natural dyes extracted from Java plum (*Syzygium cumini*), Red cabbage (*Brassica oleracea*), Hibiscus *rosa-sinensis* flower, and Begonia *rex* leaves were employed as light-absorbing dyes anchored to nanostructured mesoporous TiO<sub>2</sub> film photo anode. Simple procedures were employed in extracting natural dyes. The dye extracts were stored for four months prior to UV-vis spectra and photoelectrical measurements. The absorption spectra analyses for all extracts carried out in the wavelength range 350 to 800 nm, showed a wide and significant absorption spectrum in UV and visible regions. Photovoltaic parameters such as short-circuit current ( $J_{sc}$ ), open-circuit voltage ( $V_{oc}$ ), fill factor ( $FF$ ), power output ( $P_m$ ), and energy conversion efficiency ( $\eta$ ) were determined for the four dyes. Conversion efficiencies obtained from Java plum, Red cabbage; Hibiscus flower and Begonia *rex* were 0.098, 0.051, 0.081, and 0.094%, respectively. Efficiency of fabricated cells and cell characteristics were found to correlate with absorption spectra of dyes.

© Emerging Academy Resources

**KEYWORDS:** Anthocyanin, Natural Dye, Extracts, Dye Sensitized Solar Cell (DSSC), Titanium Oxide (TiO<sub>2</sub>)

### INTRODUCTION

Dye-sensitized solar cells (DSSC) have attracted considerable attention ever since M. Grätzel demonstrated their ability to convert solar energy into electricity (Grätzel, 2001). A DSSC is composed of a nanocrystalline porous semiconductor electrode-absorbed dye, a counter electrode, and an electrolyte. The dye plays a key role as a sensitizer in absorbing and transforming sunlight solar energy into electric energy. Usually, transition metal coordination compounds (ruthenium polypyridyl complexes) are used as the sensitizers due to their intensive charge-transfer absorption in the whole visible range and highly efficient metal-to-ligand charge transfer. Ruthenium polypyridyl complexes, however, contain heavy metals, which are undesirable from the environmental aspect point of view (Wongcharee, Meeyoo, & Chavadej, 2007). Moreover, synthesis of these complexes is complicated and costly and thus limits their large-scale applications in solar cells. As such, there has been a further strategy to use alternative inexpensive and environmental friendly dyes such as ruthenium free complex metals, organic dyes (Pradhan, Batabyal, & Pal, 2007). Organic sensitizers have shown good conversion efficiencies indicative of their promising potential as photosensitizers in DSSC (Hara et al., 2004; Ito et al., 2006). However, despite of their good performance, the synthesis of these dyes are time-consuming and laborious (Seigo Ito, 2011). On the other hand, natural dyes found in flowers, leaves, and fruits which resemble organic dye can be extracted by simple procedures. The use of these natural dyes as

sensitizers in DSSCs represents a very attractive alternative to organic dyes, since natural dyes are cheap, readily available, easy to extract, environment friendly, and less toxic. Normally most fruits, flowers and leaves show various colors and contain several pigments which are easily extracted (Calogero & Marco, 2008). The leaves of most green plants are rich in chlorophyll and its application as natural dye has been investigated in many related studies as potential DSSC sensitizers (Chang et al., 2013; Tennakone, Kumara, Kumarasinghe, Sirimanne, & Wijayantha, 1996; Wang et al., 2005). Anthocyanins are natural compounds that give color to fruits and plants and are also largely responsible for the purple-red color of leaves and the red color of flower buds and have been widely used in DSSC (Fernando & Senadeera, 2008; Rossetto et al., 2002).

In this study, we report the performance of four locally available natural dyes extracted from Java plum (*Syzygium cumini*), Red cabbage (*Brassica Oleracea*), Hibiscus *rosa-sinensis* flower, and Begonia *rex* leaves. According to previous studies, Java plum (Polo & Iha), Red cabbage (Li, Ku, Chen, Ali, & AlHemaid, 2013), Hibiscus *rosa-sinensis* (Calogero et al., 2010) mainly contain anthocyanins while Begonia *rex* (Zhou, Wu, Gao, & Ma, 2011) contains both anthocyanin and chlorophyll.

### MATERIALS AND METHODS

#### Preparation of natural dye solutions (extracts)

Four natural dyes from Java plum (*Syzygium cumini*), Red cabbage (*Brassica oleracea*), Hibiscus *rosa-sinensis*

flowers, and Begonia rex leaves were used. They were placed in a solar dryer for couple of days to dry until their weight became invariant. The average temperature inside the solar dryer was measured to be ~ 40°C. After drying, the flowers were crushed using laboratory blender. Approximately 10 g of each powdered sample was dissolved in 50 ml of ethanol (96%)/ distilled water (1:1) at room temperature and the resultant mixture was agitated without exposure to sunlight for 48 h. After extraction, the solid residues were filtered and the dye solutions stabilized at pH 1.5 and stored at 4°C that was reported by Yusoff (Yusoff, Kumara, Lim, Ekanayake, & Tennakoon, 2014) as the suitable storage temperature for the stability of anthocyanin. After four months the dye solutions were used for UV-vis spectra and photoelectrical measurement.

### Preparation of Transparent Conducting Glass

Transparent conducting glass (F: SnO<sub>2</sub>-doped, FTO) purchased from Solaronix-Switzerland was used in this study. The FTO glass was cut into small pieces of 3 cm × 3 cm using a diamond glasscutter. Prior to cutting the conducting side of the FTO glass was determined using a multimeter. The conductive surface of the glass to be scribed was carefully cleaned using tissue paper. It was important to clean the surface of since even the smallest dust particles can interrupt the cut, which can cause an uncontrolled break.

### TiO<sub>2</sub> slide preparation

The TiO<sub>2</sub> slides (working electrode) were created as follows; first, fluorine-doped tin oxide (FTO) glass substrates (3.0 cm x 3.0 cm) were tested again to determine the conductive side using a multimeter. Each substrate was taped on the conductive sides to create a 2 cm x 2 cm square at the center of each substrate. Next, commercial TiO<sub>2</sub> (P25, Degussa paste, Solaronix-Switzerland) was spread across the substrate with a glass-stirring rod in an even layer, and the substrate was dried for about ten minutes. The tape was then removed and the slides were pre-heated at 100°C for 15 min and then annealed at 450 °C for 30 min. These slides were then soaked in respective dye solutions for 24 h for pigments adsorption.

### Graphite counter electrode

The counter electrodes were prepared by coating FTO plates with carbon on the conducting side using a soft pencil to apply a light carbon film to the entire conductive side of the plate. Any loose graphite particles was gently removed. This thin carbon layer serves as a catalyst for the triiodide-to-iodide regeneration reaction.

### DSSC assembling

DSSCs were assembled following the procedure reported in the literature (D. Zhang et al., 2008). The catalyst-coated counter electrode was placed that the conductive side of the counter electrode faced the TiO<sub>2</sub> film. The iodide electrolyte solution (Iodolyte.HI-30, Solaronix-Switzerland) was placed at the edges of the plates. The liquid was drawn into the space between the electrodes by

capillary action. Two binder clips were used to hold the electrodes together.

### Characterization and measurement

The absorption spectrum of each dye solutions was recorded using a UV-vis spectrophotometer (Hitachi U-2000). For the UV-vis measurements dye solutions were diluted by a factor of 5. The dilution was done in order to overcome the problem of aggregation which gives a turbid suspension that may increase or decrease the apparent absorbance of the dye solution and thus cause deviations from the Beer-Lambert law. But for the adsorption of dye on TiO<sub>2</sub> films, concentrated dyes were used.

Testing of photoelectrical performance of the DSSC was done outdoors using solar illumination from the sun, and the irradiance (70±1) mW/cm<sup>2</sup> was measured using the luxmeter. The set up of the experiment are schematically represented in Figure 1. For the first step, the resistance was set at maximum, and values of current and voltage were recorded. The other values of current and voltage were measured by decreasing resistance until the voltage reached nearly zero while current reached maximum. Curves for current density (*J*) – voltage (*V*) and power (*P*) - voltage (*V*) were plotted. Based on *J-V* and *P-V* results the fill factor (*FF*) was calculated using Eq. (1):

$$FF = \frac{J_{mp} \times V_{mp}}{I_{sc} \times V_{oc}} \quad (1)$$

where *J<sub>mp</sub>* and *V<sub>mp</sub>* are the photocurrent density and photovoltage for maximum power output *P<sub>m</sub>*; *J<sub>sc</sub>* and *V<sub>oc</sub>* are the short-circuit photocurrent density and open-circuit photovoltage, respectively. The overall energy conversion efficiency (*η*) was calculated using Eq. (2):

$$\eta = \frac{I_{sc} \times V_{op} \times FF}{P_{in}} \quad (2)$$

where *P<sub>in</sub>* is the power of incident light.

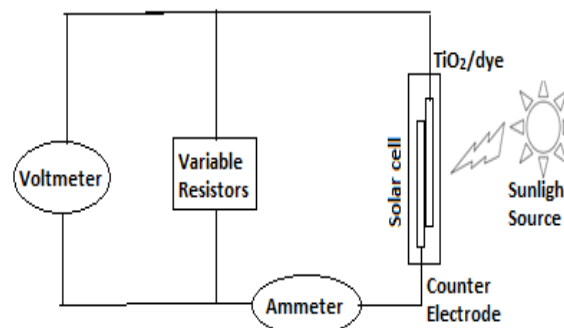

Figure 1: Schematic diagram for measurement of performance of DSSC.

## RESULTS AND DISCUSSION

### Absorption spectra of natural dyes

Figures 2(a)-(d) show the absorption spectra of the Java plum, Red cabbage, Hibiscus, and Begonia rex respectively. As shown in Figure 2a, Java plum has a broad and strong absorption in the green region (485 -

580 nm) with maximum peak at 530 nm. Begonia rex dye extract absorbs most strongly in the violet-blue and red regions with absorption peaks at 385 nm and 650 nm. The absorption in red region shows presence of chlorophyll in begonia rex (Zhou et al., 2011). Red cabbage and Hibiscus both strongly absorbs in blue-green regions with absorption range of 460 - 575 nm and maxima at 540 and 510 nm, respectively. Also Hibiscus has a peak at 380 nm and thus showing some absorption in violet region. The absorption spectra of Java plum, Red cabbage, and Hibiscus show absorption features and wavelength range in the UV and visible, and are in correlation with previously reported studies (Alhamed, Issa, & Doubal, 2012; Chang et al., 2013; Mphande & Pogrebnoi, 2014; Polo & Iha).

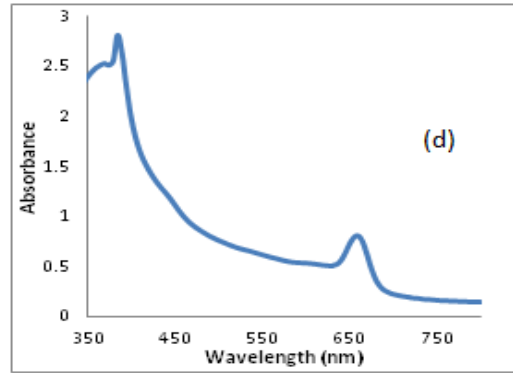
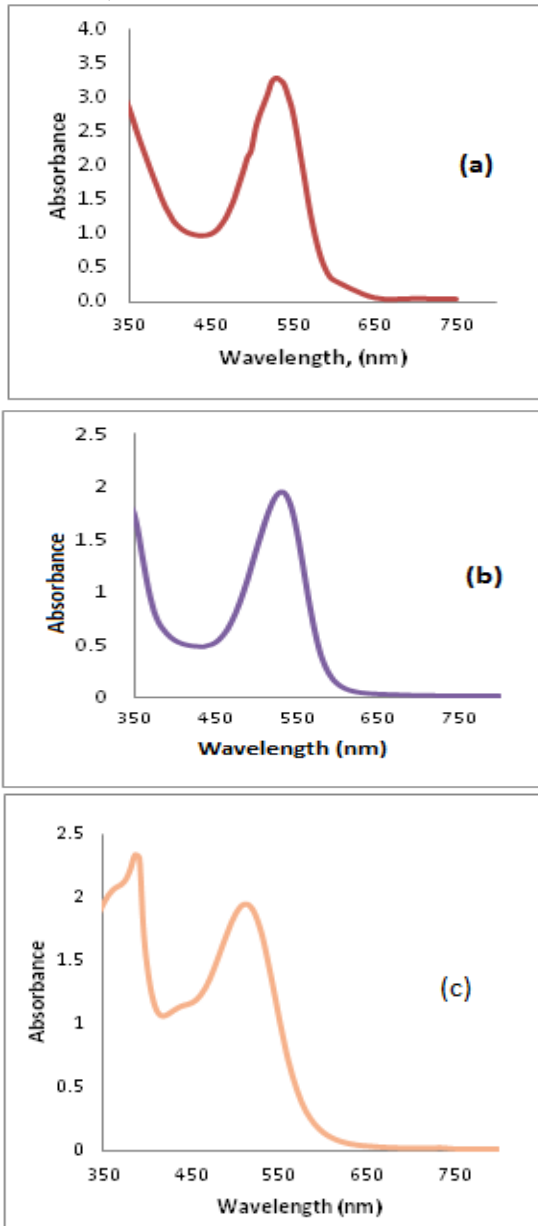

Figure 2: Absorption Spectra of (a) Java plum (b) Red cabbage (c) Hibiscus and (d) Begonia rex

### Photovoltaic Properties

Photovoltaic measurements of the fabricated DSSCs based on the four natural dyes Java plum, Red cabbage, Hibiscus, and Begonia rex were performed by measuring the J-V curves under outdoor sunlight irradiation. Figure 3 shows variation of current density-voltage curves for the four natural dyes. All J-V curves show characteristics typical for a photovoltaic device, which proves that all the extracts display light harvesting properties and charge transfer sensitization of the TiO<sub>2</sub> semiconducting film. Figure 4 shows the power curves obtained as a function of voltage. Table 1 summarizes the performance of the DSSC in terms of short-circuit current density ( $J_{sc}$ ), open-circuit voltage ( $V_{oc}$ ), maximum power output ( $P_m$ ), fill factor ( $FF$ ), and energy conversion efficiency ( $\eta$ ). As depicted from Table 1, Java plum showed the highest efficiency (0.098%) compared to the other dye extracts while Red cabbage had the lowest efficiency (0.051%). DSSC fabricated from Hibiscus flower and Begonia rex leaves gave conversion efficiency of about 0.094 and 0.081% respectively.

These conversion efficiencies obtained are in correlation with absorption displayed in Figure 2 where the highest absorption was that of Java plum followed by Begonia rex, Hibiscus, and lastly Red cabbage. Also the curves of P - V in Figure 4 are consistent with that for J - V curves where the Java plum shows the maximum power followed by Begonia rex, Hibiscus, and Red cabbage. The conversion efficiency of DSSC made from Begonia Rex and Java Plum as displayed in Table 1, showed insignificant difference due to their slight difference in open circuit voltage and short current density. Despite Red cabbage having lowest efficiency, it was found to have the highest fill factor. This has been contributed by the shape of J-V curve of red cabbage, which looks better than the rest due to constancy of the current. Therefore the DSSC made from Red cabbage have less parasitic losses compared to all the other cells and thus good quality cell. There are slight differences in short-current densities for DSSC made from Begonia rex, Hibiscus and Java plum while that for Red cabbage are much lower compared to others

Table 1: Photoelectrical parameters of DSSCs sensitized with natural dyes from different sources

Dye source	$V_{oc}$ (V)	$J_{sc}$ ( $\text{mA}/\text{cm}^2$ )	$V_{mp}$ (V)	$J_{mp}$ ( $\text{mA}/\text{cm}^2$ )	$P_m$ ( $\text{mW}/\text{cm}^2$ )	FF (%)	$\eta$ (%)
Begonia rex	0.463	0.351	0.260	0.252	0.066	41	0.094
Hibiscus	0.452	0.316	0.279	0.203	0.057	40	0.081
Java Plum	0.476	0.335	0.280	0.244	0.068	43	0.098
Red Cabbage	0.443	0.178	0.276	0.132	0.037	46	0.051

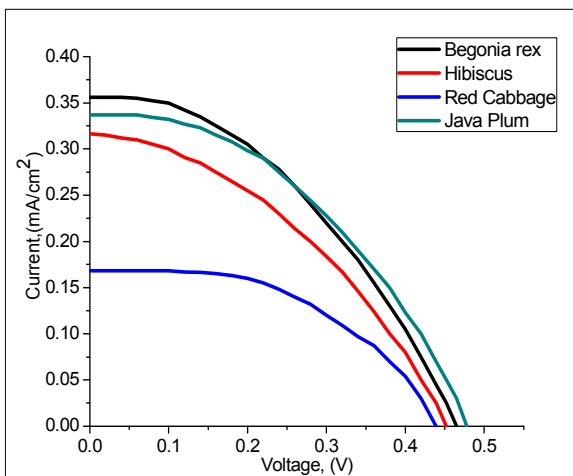

Figure 3: Current density ( $J$ ) versus Voltage ( $V$ ) curves for natural dyes from Java plum, Hibiscus, Red cabbage and Begonia rex

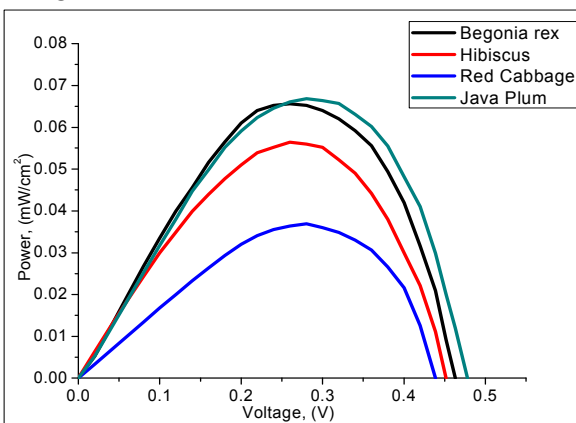

Figure 4: Power ( $P$ ) versus Voltage ( $V$ ) curves for natural dyes from Java plum, Hibiscus, Red cabbage and Begonia Rex

It has been earlier reported that conversion efficiency of most DSSC made from natural dyes suffers from low open circuit voltage (Zhang Z., 2008), which is also the case in this study where the open circuit obtained range from 0.4 – 0.5 V. This can be due to both possible electron/dye cation recombination pathways and the acidic dye adsorption environment. Finding different additives for improving  $V_{oc}$  might result in larger conversion efficiencies.

## CONCLUSION

In this work, we have successfully demonstrated the sensitization of nanocrystalline  $\text{TiO}_2$  using four local natural dyes extracts from Begonia rex leaves, Red cabbage leaves, Hibiscus flower and Java plum peels under outdoor sunlight illumination. The J-V curves have the expected shape for a photovoltaic device and are consistent with previous studies on the similar material. We have described and compared their UV-vis spectra absorption and photoelectrical performance with respect to one another. The extract from Java plum peels achieved solar energy conversion efficiency of 0.098%, which is the highest obtained among all sensitized cells. Natural dye based cells appear to be limited by low  $V_{oc}$  and a large decrease in photocurrent, probably due to dye degradation

## ACKNOWLEDGEMENT

The authors want to acknowledge the support provided by The Nelson Mandela Africa Institution of Science and Technology for providing financial and material support for the study undertaking. We also acknowledge Professor Alexander Pogrebnoi at NM-AIST and Doctor Nuru Mlyuka from Physics Department at University of Dar es Salaam for their comments which helped to shape the idea into real research work

## REFERENCES

- Alhamed, M., Issa, A. S., & Doubal, A. W., 2012. Studying of natural dyes properties as photo-sensitizer for dye sensitized solar cells (DSSC). Journal of Electron Devices, 16, 1370-1383.
- Calogero, G., Di Marco, G., Cazzanti, S., Caramori, S., Argazzi, R., Di Carlo, A., & Bignozzi, C. A., 2010. Efficient dye-sensitized solar cells using red turnip and purple wild sicilian prickly pear fruits. International journal of molecular sciences, 11(1), 254-267.
- Calogero, G., & Marco, G. D., 2000. Red Sicilian orange and purple eggplant fruits as natural sensitizers for dye-sensitized solar cells. Solar Energy Materials and Solar Cells, 92(11), 1341-1346.
- Chang, H., Kao, M.-J., Chen, T.-L., Chen, C.-H., Cho, K.-C., & Lai, X.-R., 2013. Characterization of Natural Dye Extracted from Wormwood and Purple Cabbage for Dye-Sensitized Solar Cells. International Journal of Photoenergy, 2013.
- Fernando, J., & Senadeera, G., 2008. Natural anthocyanins as photosensitizers for dye-sensitized solar devices. Current Science, 95(5), 663-666.
- Grätzel, M., 2001. Photoelectrochemical cells. Nature, 414(6861), 338-344.
- Hara, K., Dan-oh, Y., Kasada, C., Ohga, Y., Shinpo, A., Suga, S., . . . Arakawa, H., 2004. Effect of additives on the photovoltaic performance of coumarin-dye-sensitized nanocrystalline  $\text{TiO}_2$  solar cells. Langmuir, 20(10), 4205-4210.

- Seigo Ito., 2011. Investigation of Dyes for Dye-Sensitized Solar Cells: Ruthenium-Complex Dyes, Metal-Free Dyes, Metal-Complex Porphyrin Dyes and Natural Dyes, Solar Cells - Dye-Sensitized Devices, Prof. Leonid A. Kosyachenko (Ed.), ISBN: 978-953-307-735-2, InTech, DOI: 10.5772/19960. Available from: <http://www.intechopen.com/books/solar-cells-dye-sensitized-devices/investigation-of-dyes-for-dye-sensitized-solar-cells-ruthenium-complex-dyes-metal-free-dyes-metal-co>
- Ito, S., Zakeeruddin, S. M., Humphry-Baker, R., Liska, P., Charvet, R., Comte, P., . . . Miura, H., 2006. High-Efficiency Organic-Dye-Sensitized Solar Cells Controlled by Nanocrystalline-TiO<sub>2</sub> Electrode Thickness. *Advanced Materials*, 18(9), 1202-1205.
- Li, Y., Ku, S.-H., Chen, S.-M., Ali, M. A., & AlHemaid, F. M., 2013. Photoelectrochemistry for Red Cabbage Extract as Natural Dye to Develop a Dye-Sensitized Solar Cells. *Int. J. Electrochem. Sci*, 8, 1237-1245.
- Mphande, B. C., & Pogrebnoi, A., 2014. Impact of Extraction Methods upon Light Absorbance of Natural Organic Dyes for Dye Sensitized Solar Cells Application. *Journal of Energy and Natural Resources*. Vol. 3, No. 3, pp. 38-45. doi: 10.11648/j.jenr.20140303.13
- Polo, A. S., & Iha, N. M. Clean and renewable energy from dye-sensitized solar cells using fruit extracts. *RIO*, 3, 91-96.
- Pradhan, B., Batabyal, S. K., & Pal, A. J., 2007. Vertically aligned ZnO nanowire arrays in Rose Bengal-based dye-sensitized solar cells. *Solar Energy Materials and Solar Cells*, 91(9), 769-773.
- Rossetto, M., Vanzani, P., Mattivi, F., Lunelli, M., Scarpa, M., & Rigo, A., 200). Synergistic antioxidant effect of catechin and malvidin 3-glucoside on free radical-initiated peroxidation of linoleic acid in micelles. *Archives of biochemistry and biophysics*, 408(2), 239-245.
- Tennakone, K., Kumara, G., Kumarasinghe, A., Sirimanne, P., & Wijayantha, K., 1996. Efficient photosensitization of nanocrystalline TiO<sub>2</sub> films by tannins and related phenolic substances. *Journal of Photochemistry and Photobiology A: Chemistry*, 94(2), 217-220.
- Wang, X.-F., Xiang, J., Wang, P., Koyama, Y., Yanagida, S., Wada, Y., . . . Tamiaki, H., 2005. Dye-sensitized solar cells using a chlorophyll derivative as the sensitizer and carotenoids having different conjugation lengths as redox spacers. *Chemical physics letters*, 408(4), 409-414.
- Wongcharee, K., Meeyoo, V., & Chavadej, S., 2007. Dye-sensitized solar cell using natural dyes extracted from rosella and blue pea flowers. *Solar Energy Materials and Solar Cells*, 91(7), 566-571.
- Yusoff, A., Kumara, N., Lim, A., Ekanayake, P., & Tennakoon, K. U., 2014. Impacts of Temperature on the Stability of Tropical Plant Pigments as Sensitizers for Dye Sensitized Solar Cells. *Journal of Biophysics*, 2014.
- Zhang, D., Lanier, S. M., Downing, J. A., Avent, J. L., Lum, J., & McHale, J. L., 2008. Betalain pigments for dye-sensitized solar cells. *Journal of Photochemistry and Photobiology A: Chemistry*, 195(1), 72-80.
- Zhang, Z., 2008. Enhancing the open-circuit voltage of Dye-sensitized solar cells: coadsorbents and alternative redox couples. ÉCOLE POLYTECHNIQUE FÉDÉRALE DE LAUSANNE. Retrieved from: [http://infoscience.epfl.ch/record/118266/files/EPFL\\_TH4066.pdf](http://infoscience.epfl.ch/record/118266/files/EPFL_TH4066.pdf)
- Zhou, H., Wu, L., Gao, Y., & Ma, T., 2011. Dye-sensitized solar cells using 20 natural dyes as sensitizers. *Journal of Photochemistry and Photobiology A: Chemistry*, 219(2), 188-194