

2014

# Designing and Simulation of an Automated Irrigation Management System Deployed by using Wireless Sensor Networks (WSN)

Haule, Joseph

Journal of Electronics and Communication Engineering

---

<http://dspace.nm-aist.ac.tz/handle/123456789/436>

*Provided with love from The Nelson Mandela African Institution of Science and Technology*

## **Designing and Simulation of an Automated Irrigation Management System Deployed by using Wireless Sensor Networks (WSN)**

Joseph Haule<sup>1</sup>, Kisangiri Michael<sup>2</sup>

<sup>1,2</sup> Department of Electronics and Telecommunication Engineering, The Nelson Mandela Institution of Science and Technology, Arusha, Tanzania

---

**Abstract:** *Wireless Sensor Networks (WSN) is currently an active research area due to its exciting technology and potential in different applications. The advantages of wireless transmission are significant reduction and simplification in wiring, allows remote sensor monitoring, such as monitoring dangerous, hazardous, allow faster deployment and installation of different types of sensors. WSN is applied in various fields including medicine, transportation, agriculture, industrial process control, global-scale environmental monitoring and precision agriculture. Availability of fresh water is one of the elementary conditions for life on Earth, however, water is a limited resource, and is having demand from several economic sectors such as tourism, industry, and agriculture. In particular, irrigated agriculture is one of the major water-consuming sectors. The above-mentioned issues justify the need for having a system which will facilitate an efficient utilization of water in the irrigation processes. This paper describes an application of wireless sensor network in designing an automated irrigation management system which monitors real time water content in the soil. The system will allow water to flow to the soil only when the soil is in the state of "Water hungry". The designed system has three units namely; slave unit, master unit and the valve control unit.*

**Keywords:** *Soil moisture sensors, real time monitoring, Automated irrigation, Simulation*

---

### **I. Introduction**

Since agriculture has been proved to be the back bone of Tanzanian economy, which is contributing more than twenty seven percent of the total economy. Agriculture sector is incorporating new technologies due to the large production demands and the diversity, quality, and market requirements inside the country and cross the borders. Automatic control techniques are incorporated in all the agricultural production levels: planting, production, harvest, post-harvest processes, and transportation. Modern agriculture is subjected to regulations in terms of quality and environmental impact, and thus it is a field where the application of automatic control techniques has increased substantially during the last years [1-3]. This paper reviews the most on the automation of irrigation management system to improve the crop production and efficient use of water sources. In Tanzania, the management of water sources has been a great problem which is facing the farmers. Recently, Wireless Sensor Networks (WSN) are becoming an important solution to this problem [4, 5]. WSN is a collection of sensor and actuators nodes linked by a wireless medium to perform distributed sensing and acting tasks [6]. The sensor nodes collect data and communicate over a network environment to a computer system, which is called, a base station. Based on the information collected, the base station takes decisions and then the actuator nodes perform appropriate actions upon the environment. This process allows users to sense and control the environment from anywhere [4]. There are many situations in which the application of the WSN is preferred, for instance, environment monitoring, product quality monitoring, and others where supervision of big areas is necessary [7]. In this paper, WSN are used in designing and simulating an automated irrigation management system.

The goal for any simulator is to accurately model and predict the behavior of a real world environment. Developers are provided with information on feasibility and reflectivity crucial to the implementation of the system prior to investing significant time and money [8]. This is especially true in sensor networks, where hardware may have to be purchased in large quantities and at high cost. Even with readily available sensor nodes, testing the network in the desired environment can be a time-consuming and difficult task. Simulation based testing can help to indicate whether or not these time and monetary investments are wise. Simulation is, therefore, the most common approach to developing and testing new protocol for a sensor networks. Many published papers contain results based only on experimental simulation. There are a number of advantages to this approach: lower cost, ease of implementation, and practicality of testing large scale networks. In order to effectively develop any protocol with the help of simulation, it is important to know the different tools available and the benefits and drawbacks therein associated [9].

## II. Design Of The System

An automated irrigation management system is designed by having three main units; slave unit, master unit and the valve control unit.

### 2.1 Slave unit

The slave unit consists of soil moisture sensors, microcontroller and the Xbee module. Soil moisture sensors reads the real time value of the moisture content available in the soil, this value is temporarily stored in the microcontroller. The xbee module is used to transfer that value of soil moisture content to the master unit which is used to make all the decisions on whether to irrigate or not depending on the value of soil moisture content available in the soil. The soil moisture is read as resistivity of the soil in between the probes of the soil moisture sensor. The soil moisture sensor is shown in the figure below



Figure 1: Soil Moisture Sensor

The figure below shows the slave unit of the automated irrigation management system by using wireless sensor network. Xbee module is used as the wireless transmitter and receiver.

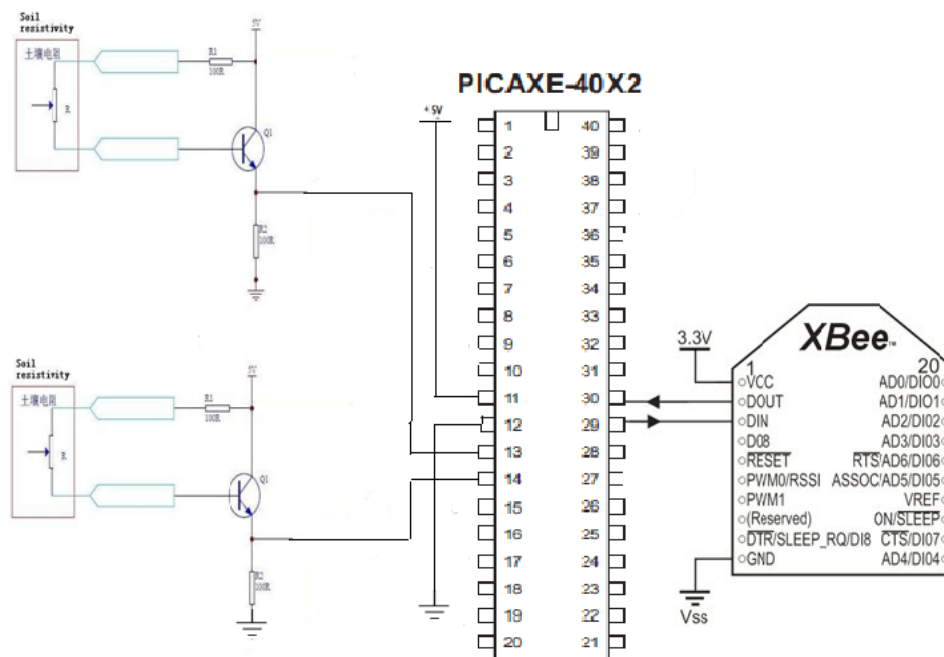

Figure 2: Slave unit

### 2.2 Master unit

The master unit consists of microcontroller, GSM modem, LCD display and xbee module. This unit is the heart of the automated irrigation system since all the decisions are made in this unit by using microcontroller. The amount of soil moisture content which is sent by the slave unit is the manipulated and

compared with the defined threshold value depending on the type of the soil and the nature of the crop planted. When the value of the soil moisture is small compared to the threshold value then the master sends the signal to command the valve control unit to open the valve and irrigate that particular area which corresponds to the sensor. On the other hand, if the value received is equal or equal to the threshold value defined, then the signal to close the valve will be sent to the valve control unit.

The amount of the soil moisture content can be sent to a database for storage by using the MAX 232 as the interface between the microcontroller and the database. In case of any fault, the message can be sent to the user by the use of GSM modem. We can also display the amount of soil moisture by using the LCD display connected to the microcontroller.

The figure below shows typical setup of the devices used in the master unit of an automated irrigation system.

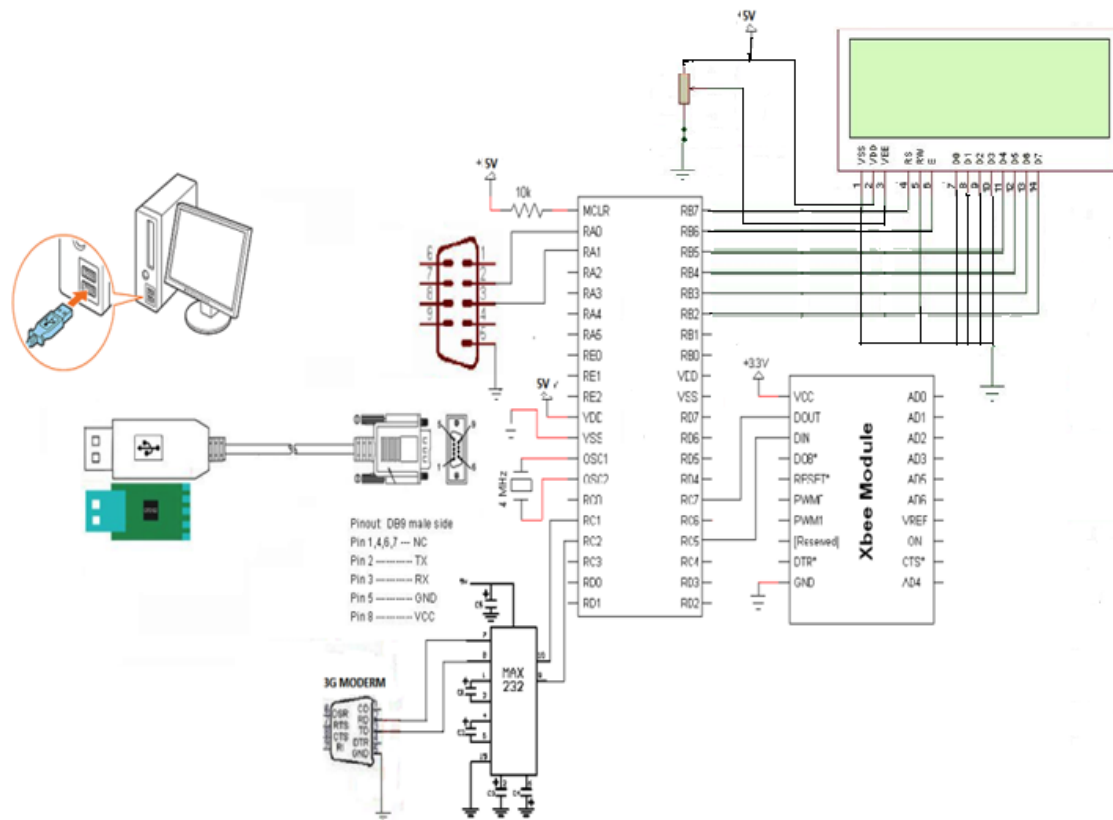

Figure 3: Master unit

### 2.3 Valve control unit

The valve control unit consists of microcontroller, xbee and valves. The Xbee module here is used as a receiver, it receives the signal from the master unit, and the microcontroller reads the value and commands the valve to close or open depending on the signal received. The valves are switched ON or OFF by using the MOSFET transistors which are used as a switch.

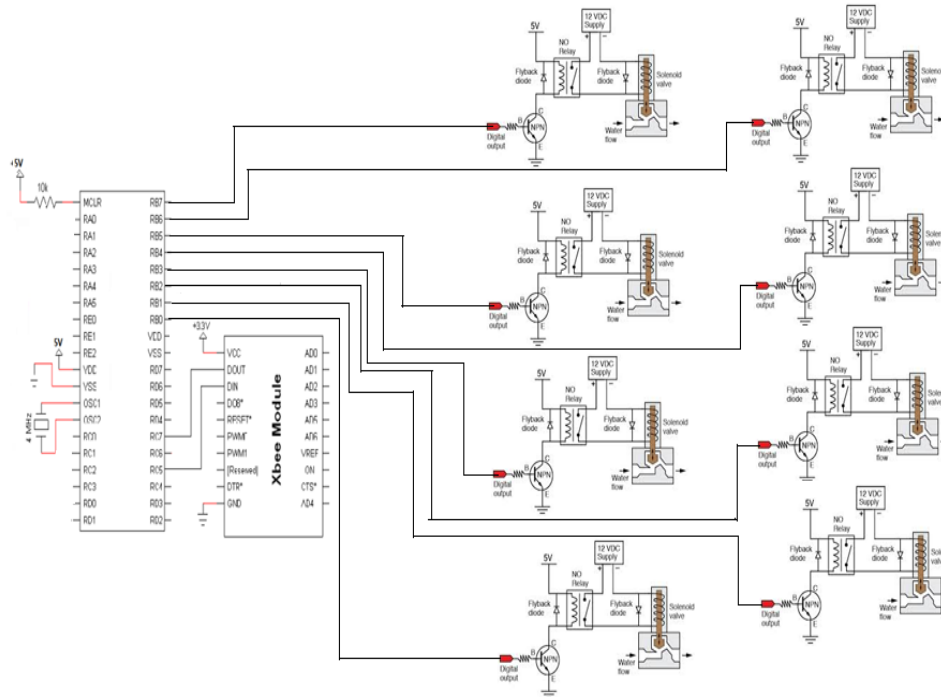

Figure 4: Valve control unit

The figure below is the enlargement of the part of the valve control unit. The figure shows from the signal received to the valve when it gives out water to the irrigation field.

Fig. 5 below shows how the valve is connected in the irrigation system. The valve is switched on and off by using the MOSFET transistor, the transistor receives the command from microcontroller. The fly back diode is connected across the windings of the solenoid valve in order to protect the valve from back electromotive force.

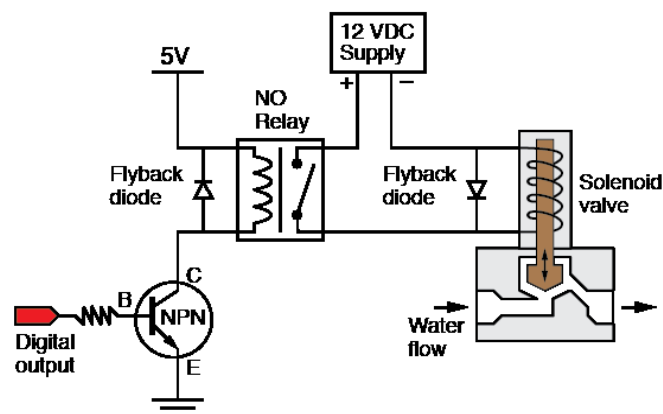

Figure 5: Solenoid Valve connection

We connect the freewheeling diode across the inductive load which is used to protect the transistor from the back electromotive force (EMF) of the inductive load, which is the valve. Freewheeling diode is used to eliminate fly back, which is the sudden spike seen across an inductive load when its supply is suddenly reduced or removed[10]. This is due to the fact that by doing so, you can overcome the inductance faster and then you can ultimately push more current through the windings. The average current must be less than the recommended current through the solenoid, or it will overheat[11].

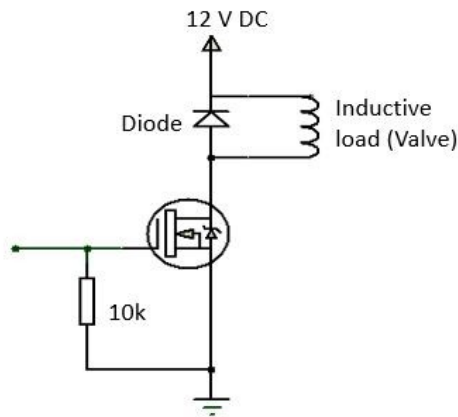

Figure 6: Switching mechanism of the solenoid valve

### III. Simulation Results.

The designed system is simulated by using proteus 7 design suit software. In the design, the level of the soil moisture sensors will be varied from dry to wet, and the microcontroller will read the value and send to the master unit for decision making. Depending on the value of the soil moisture available in the soil, the LCD display will display whether it's WET or DRY. Then the signal will be sent to the valve control unit to open or close the valve. For the simulation purpose the valves are represented by the Light Emitting Diode (LED), if the valve is to be opened then the LED will switch ON, and if the valve is to be closed then the LED will switch OFF.

Soil moisture sensors are distributed into the different areas connected to the slave units, for this simulation we will consider having two different plots each having two soil moisture sensors.

The setup for simulation of an automated irrigation management system by using wireless sensor network is shown below

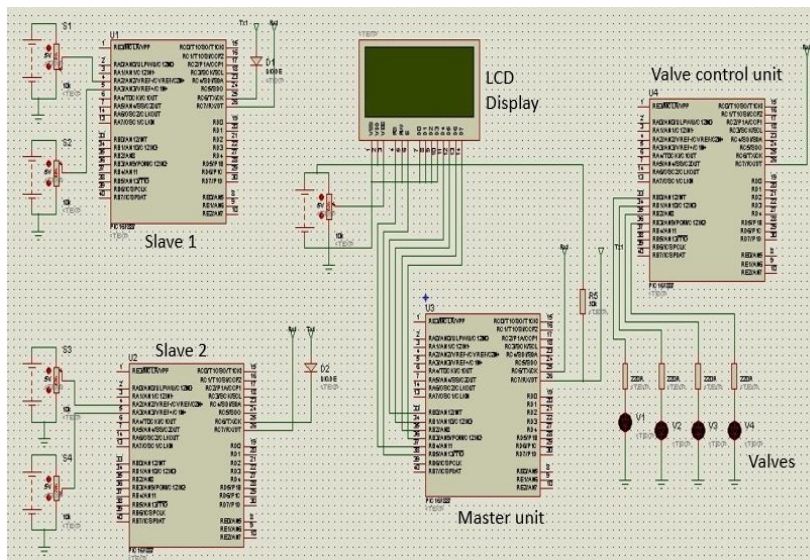

Figure 7: Simulation setup for automated irrigation system

#### Case 1:

If the sensor 1 of area 1 (Slave 1) reads the value of the soil moisture to be below the threshold value then the LCD display will display “DRY-IRRIGATE” and the master unit is responsible to send the signal to the valve control unit to switch ON the LED. If the LED is lighting, that is red light this implies that the valve is opened and the irrigation is taking place at the point where the sensor 1 is located. All the sensors in the field are given the corresponding addresses which matches the valves in the valve control unit.

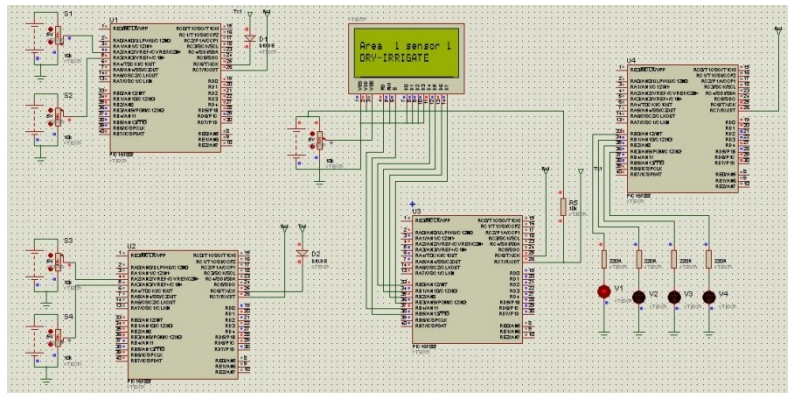

Figure 8: Area 1 Sensor 1 is dry, irrigation should take place

**Case 2:**

If the place where sensor 2 is installed there is enough soil moisture content, then the LCD will display “WET- DON’T IRRIGATE” and the signal to close the corresponding valve (Valve 2) will be sent to the valve control unit.

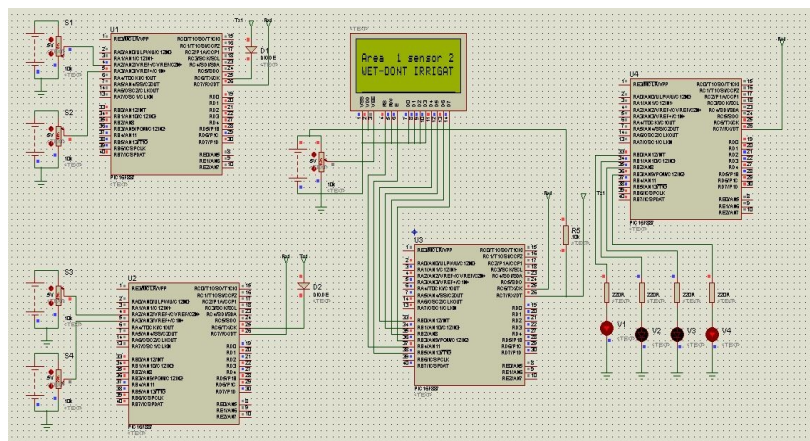

Figure 9: Area 1 Sensor 2 is wet, irrigation should not take place

**Case 3:**

If the whole area is dry and it needs to be irrigated, the master will send the signal to switch ON the respective valve which corresponds to the sensor location. For this case all the valves will switch ON and the irrigation from all four valves will take place. When the irrigation is taking place, the soil moisture sensors will continue reading the real time soil moisture values and forward it to master unit, master unit will be comparing the value received with the threshold value and make decision whether to continue irrigating or not.

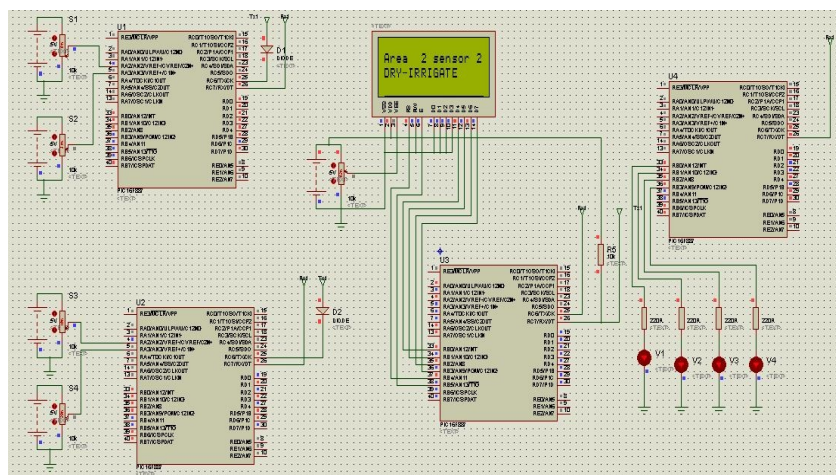

Figure 10: Irrigation is taking place over the whole area

#### **IV. Conclusion And Future Work**

Water resources are becoming scares in many Tanzanian semi-arid areas for the last several years. The importance of optimized and efficient irrigation management system development which is fully automated has become the need of time especially the irrigation system that takes decisions over crops soil water contents and environmental parameters. This will increase the crop production as well as efficient utilization of water resources. In this paper, an automated irrigation management system by using wireless sensor networks were designed and simulated successfully. If the threshold value of the soil moisture depending on the type of soil and the crop planted is reached, then the valve will close automatically hence water will not waste unnecessarily. Our future work is to implement an automated irrigation management system by using the wireless sensor networks and test in the real environment by monitoring its performance

#### **Acknowledgement**

I would like to express my sincere thanks to the Nelson Mandela Institution of Science and Technology for the financial support during this research. I also like to thank Dr. Kisangiri Michael for his supervision in this research and accepting co-authoring in this paper

#### **References**

##### **Journal Reference**

- [1] I. Farkas, "Modelling and control in agricultural processes," *Computers and Electronics in Agriculture*, vol. 49, pp. 315-316, 2005.
- [2] R. E. King and N. Sigrimis, "Computational intelligence in crop production," *Computers and Electronics in Agriculture*, vol. 31, pp. 1-3, 2001.
- [3] N. Sigrimis, P. Antsaklis, and P. P. Groumpos, "Advances in control of agriculture and the environment," *Control Systems, IEEE*, vol. 21, pp. 8-12, 2001.
- [4] L. Gonda and C. E. Cugnasca, "A proposal of greenhouse control using wireless sensor networks," in *Proceedings of 4th World Congress Conference on Computers in Agriculture and Natural Resources*, Orlando, Florida, USA, 2006.
- [5] V. L. Narasimhan, A. A. Arvind, and K. Bever, "Greenhouse asset management using wireless sensor-actor networks," in *Mobile Ubiquitous Computing, Systems, Services and Technologies, 2007. UBICOMM'07. International Conference on, 2007*, pp. 9-14.
- [6] Y. Zhu, X. Zhong, and J. Shi, "The design of wireless sensor network system based on zigbee technology for greenhouse," in *Journal of Physics: Conference Series*, 2006, p. 1195.
- [7] F. Xia, Y.-C. Tian, Y. Li, and Y. Sung, "Wireless sensor/actuator network design for mobile control applications," *Sensors*, vol. 7, pp. 2157-2173, 2007.
- [8] V. Mytri and S. R. Patil, "Simulation Environments for Wireless Sensors Networks," *Simulation*, vol. 1, 2010.
- [9] S. Park, A. Savvides, and M. B. Srivastava, "Simulating networks of wireless sensors," in *Proceedings of the 33rd conference on Winter simulation, 2001*, pp. 1330-1338.
- [10] T. Miller and R. Rabinovici, "Back-EMF waveforms and core losses in brushless DC motors," *IEE Proceedings-Electric Power Applications*, vol. 141, pp. 144-154, 1994.
- [11] L. Parsa and H. A. Toliyat, "Five-phase permanent-magnet motor drives," *Industry Applications, IEEE Transactions on*, vol. 41, pp. 30-37, 2005.