

2018-09

# Monitoring of the grain crops in storage facilities through wireless communication technology

Mazima, Johevajile Kamala

NM-AIST

---

<http://dspace.nm-aist.ac.tz/handle/123456789/304>

*Provided with love from The Nelson Mandela African Institution of Science and Technology*

**MONITORING OF THE GRAIN CROPS IN STORAGE FACILITIES  
THROUGH WIRELESS COMMUNICATIONTECHNOLOGY**

**Johevajile Kamala Mazima**

**A Dissertation Submitted in Partial Fulfillment of the Requirements for the Degree of  
Doctor of Philosophy in Information and Communication Science and Engineering of  
the Nelson Mandela African Institution of Science and Technology**

**Arusha, Tanzania**

**September, 2018**

## ABSTRACT

The storage condition measurement of grain crops is almost non-invasive to date; most of the technologies can be used to monitor the storage. Electromagnetic radiation is still popular wireless technique for grain storage condition management. It has led to the way of exploring safe methods for grain storage. The studies have shown that data detection using electromagnetic techniques has been attempted from various stances such as invasive and non-invasive approaches. Most of the existing methods utilize some form of dielectric techniques. Despite the current development, there is an increasing need for monitoring large amount of stored grains. The trend indicates the grain spoilage due to the inefficiency of detecting the climate parameters such as temperature and moisture content from storage of large amount of grains. The aim of this work is to propose the method capable of monitoring the storage facility with large amount of grains through wireless communication technology. It took into account the dielectric and radio refractive quantity properties of grains, and storage prediction based on hidden Markov for the elegant monitoring of the stored grains. The model was designed and implemented based on ZigBee technology for remote communication, where wheat is considered as the prime cereal grains for storage in large quantity. It is also tested based on the robustness, accuracy and precision to confirm its viability in real time. The results showed that the proposed method is robust in response to the climatic changes in the storage and is capable of monitoring the storage condition accurately with the average range of minimal relative error between -6.67 to 6.73% for temperature and -3.63 to 4.96% for moisture content measurements to both hard and soft wheat storages. The forecasted results were precisely done over 90% for most of the time. This justified that the model is capable of monitoring the climatic conditions of the storage for safe and future use of wheat grains, therefore the proposed model is recommended for the implementation in real time environment.

## DECLARATION

I, **Johevajile Kamala Mazima** do hereby declare to the Senate of Nelson Mandela African Institution of Science and Technology that this dissertation is my own original work and that it has neither been submitted nor being concurrently submitted for a degree award in any other institution.

<b>Johevajile Kamala Mazima</b>		<u>06/09/2018</u>
<b>Name</b>	<b>Signature</b>	<b>Date</b>

<b>Prof. Agbinya Johnson</b>	_____	_____
<b>Name</b>	<b>Signature of supervisor 1</b>	<b>Date</b>

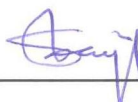
<b>Dr. Shubi F. Kaijage</b>		<u>6/9/2018</u>
<b>Name</b>	<b>Signature of supervisor 2</b>	<b>Date</b>

<b>Dr. Emmanuel C. Manasseh</b>		<u>6.9.2018</u>
<b>Name</b>	<b>Signature of supervisor 3</b>	<b>Date</b>

## **COPYRIGHT**

This dissertation is copyright material protected under the Berne Convention, the Copyright Act of 1999 and other international and national enactments, in that behalf, on intellectual property. It must not be reproduced by any means, in full or in part, except for short extracts in fair dealing; for a researcher's private study, critical scholarly review or discourse with an acknowledgement, without a written permission of the Deputy Vice Chancellor for Academic, Research and Innovation, on behalf of both the author and the Nelson Mandela African Institution of Science and Technology.

## CERTIFICATION

The undersigned certify that, they have read and hereby recommend for acceptance by the **Nelson Mandela African Institution of Science and Technology** a dissertation titled **“Monitoring of Grain Crops in Storage Building through Wireless Communication Technology”** “in partial fulfillment of the requirements for the degree of doctor of philosophy in Information and Communication Science and Engineering of the **Nelson Mandela African Institution of Science and Technology**.

**Prof. Agbinya Johnson**

Name

Signature of supervisor 1

Date

**Dr. Shubi F. Kaijage**

Name

Signature of supervisor 2

Date

**Dr. Emmanuel C. Manasseh**

Name

Signature of supervisor 3

Date

## **ACKNOWLEDGEMENT**

First and foremost, I would like to express my sincere gratitude to my supervisors, Dr. Shubi F. Kaijage, Prof. Agbinya Johnson and Dr. Emmanuel C. Manasseh for their guidance and support throughout the period of my study.

I would like to thank NM-AIST community and the Government of Tanzania for offering me a scholarship and supportive environment for the accomplishment of this study.

This work would have not been possible without the support from my employer, the Moshi Co-operative University (MoCU) for granting me a study leave to attend the program.

Special thanks are due to my parents, my mother Ernestina K. Mazima and late father Timothy Mazima for their support and guidance during upbringing, without them, I would not have been who I am today.

Last but not least, my thanks go to my wife and children. From depths of my heart, I would like to thank my wife Freddah K. Mazima and my children for her support, patience and love during my absence for studies. Thanks to our kids Jovan, Joyce and Jane for their patience and love during this whole period.

## **DEDICATION**

This work is dedicated to wife and children for their love, continuous support and encouragement for the whole period of my study.



## TABLE OF CONTENTS

DECLARATION .....	ii
COPYRIGHT.....	iii
CERTIFICATION.....	iv
ACKNOWLEDGEMENT .....	v
DEDICATION.....	vi
TABLE OF CONTENTS .....	vii
CHAPTER ONE.....	1
GENERAL INTRODUCTION .....	1
1.0 Introduction .....	1
1.1 Problem Statement .....	3
1.2 Objectives.....	4
1.2.1 Main Objective .....	4
1.2.2 Specific Objective .....	4
1.3 Research Questions .....	4
1.4 Significance of the Research .....	4
1.5 Research Methodology.....	4
CHAPTER TWO.....	7
An Overview of Electromagnetic radiation in Grain Crops .....	7
Abstract .....	7
2.0 Introduction .....	7
2.1 Electromagnetic Radiation Basic Laws.....	8
2.2 Electromagnetic Fields with Cereal Crops.....	9
2.3 Electrical Properties of Grain Crops .....	11
2.3.1 Temperature Effect.....	11
2.3.2 Frequency Effect .....	12
2.3.3 Moisture Content Effect .....	13
2.3.4 Bulk Density Effect.....	15
2.3.5 Storage Time Effect.....	16
2.4 Electromagnetic Heating Effects on Cereal Crops.....	16
2.5 Electromagnetic Sensing Effects on Cereal Crops.....	16
2.6 Conclusion.....	17
CHAPTER THREE.....	19

Stochastic Modeling technology for Grain Crops Storage Application: Review.....	19
Abstract .....	19
3.0 Introduction .....	19
3.1 Literature review .....	19
3.1.1 Artificial Neural Networks (ANNs).....	20
3.1.2 Markov Chain (MC).....	21
3.1.3 Hidden Markov Model (HMM) .....	22
3.1.4 Strengths and limitation of forecasting techniques .....	25
3.2 Forecasting Techniques.....	27
3.2.1 Artificial Neural Networks Model (ANN) .....	27
3.2.2 Markov Chain Model (MC) .....	29
3.2.3 Hidden Markov Model (HMM) .....	30
3.3 Discussion and Conclusion .....	34
CHAPTER FOUR.....	36
The Designed Method for Determining Temperature and Moisture Contents in the Wheat Grain Storage using Electromagnetic Properties .....	36
Abstract .....	36
4.0 Introduction .....	36
4.1 Methods for Measuring Climatic Parameters in Cereal Crops .....	37
4.1.1 Measurement by Dielectric Measuring Methods .....	37
4.1.2 Measurement by Isothermal Measuring Methods .....	38
4.2 Methodology .....	40
4.3 Results and Discussion.....	42
4.4 Conclusion.....	45
CHAPTER FIVE.....	47
A Novel Design for Forecasting Wheat Grains Storage Condition using Hidden Markov Model .....	47
Abstract .....	47
5.0 Introduction .....	47
5.1 Research Works on the Forecasting by Hidden Markov Model .....	48
5.2 Methodology .....	52
5.3 Results and discussions .....	57
5.4 Conclusion.....	63

CHAPTER SIX.....	63
Performance Evaluation of the Model for Monitoring the Grain Condition in the Storage Facility Based on ZigBee Technology .....	64
Abstract .....	64
6.0 Introduction .....	64
6.1 Literature review .....	65
6.2 Methodology .....	68
6.2.1 Experiment setup .....	69
6.3 Results and discussions .....	73
6.3.1 Model Robustness .....	73
6.3.2 Model Accuracy .....	89
6.3.3 Model Precision.....	95
6.4 Conclusion.....	101
CHAPTER SEVEN.....	103
GENERAL DISCUSSION, CONCLUSION AND RECOMMENDATIONS .....	103
7.1 General Discussion.....	103
7.2 General conclusion .....	106
7.3 Recommendations .....	108
REFERENCES .....	109
APPENDICES .....	138

## LIST OF TABLES

Table 1: Dielectric Properties of Grains at different moisture contents and frequencies .....	14
Table 2: Key points of survey on weather condition forecasting techniques .....	24
Table 3: Key points of survey on crop activities forecasting techniques .....	25
Table 4: Strengths and limitations of modeling techniques.....	27
Table 5: Modified Henderson Constants for moisture contents in wheat species .....	42
Table 6: Hard wheat grains experiment data measured by the proposed technology during storage in the greenhouse.....	79
Table 7: Soft wheat grains experiment data measured by the proposed technology during storage in the greenhouse.....	80
Table 8: Hard wheat grains experiment data measured by the proposed technology during storage in the open area.....	83
Table 9: Soft wheat grains experiment data measured by the proposed technology during storage in the open area.....	84
Table 10: Comparison of hard wheat storage data measured by the proposed method and probes.....	85
Table 11: Comparison of soft wheat storage data measured by the proposed method and dip sensors.....	85
Table 12: Accuracy relative error of the hard wheat data measured by the proposed model and dip sensor during storage in the open air area.....	91
Table 13: Accuracy relative error of the soft wheat data measured by the proposed model and dip sensor during storage in the open air area.....	92

## LIST OF FIGURES

Figure 1: Overall layout of granary monitoring .....	2
Figure 2: Proposed model summary .....	6
Figure 3: When electromagnetic strikes with high loss factor .....	10
Figure 4: Variation of dielectric constant of loose fill .....	12
Figure 5: Variation of loss factor of loose fill buckwheat .....	12
Figure 6: Dielectric constant of hard red winter wheat.....	13
Figure 7: Loss factor of hard red winter wheat as .....	13
Figure 8: Variation of dielectric constant of .....	15
Figure 9: Biology neuron .....	28
Figure 10: Artificial neuron .....	28
Figure 11: ANN structure .....	29
Figure 12: HMM topology.....	30
Figure 13: Studies of modeling techniques on crop.....	33
Figure 14: Studies on weather condition .....	34
Figure 15: Activities forecasted using modeling techniques .....	34
Figure 16: Moisture content and temperature determination method layout.....	40
Figure 17: Frequency response with refractivity .....	42
Figure 18: Frequency response with wheat dielectric constant .....	43
Figure 19: Temperature as the function of dielectric constant of whea .....	43
Figure 20: Moisture content as the function of dielectric constant of wheat .....	44
Figure 21: Moisture content as the function of refractivity .....	44
Figure 22: Relative humidity as the function of moisture content .....	45
Figure 23: Moisture content as the function of temperature.....	45
Figure 24: Wheat grain storage condition forecasting method layout .....	52
Figure 25: Markovian hidden states .....	54
Figure 26: Original Hidden Markov model .....	54
Figure 27: Estimated Hidden Markov model topology .....	56
Figure 28: Transition probabilities from other states to cold state .....	57
Figure 29: Transition probabilities from other states to warm state .....	57
Figure 30: Transition probabilities from other states to hot state .....	58
Figure 31: Observation probabilities of Dry state given .....	58
Figure 32: Observation probabilities of wet state given .....	59

Figure 33: Observation probabilities of spoil state given .....	59
Figure 34: Varying time in 10 days via (a) observations and (b) hidden states .....	60
Figure 35: Varying time in 20 days via (a) observations and (b) hidden states .....	60
Figure 36: Varying time in 30 days via (a) observations and (b) hidden states .....	61
Figure 37: Varying time in 60 days via (a) observations and (b) hidden states .....	61
Figure 38: Varying time in 90 days via (a) observations and (b) hidden states .....	62
Figure 39: Varying time in 120 days via (a) observations and (b) hidden states.....	62
Figure 40: Varying time in 180 days via (a) observations and (b) hidden states .....	63
Figure 41: Schematics of the methodology of wheat storage condition .....	69
Figure 42: Schematic diagram of primary levels for the wheat storage condition .....	70
Figure 43: Wheat grains in the storage container .....	71
Figure 44: Greenhouse setup experiment .....	71
Figure 45: Open air space setup .....	72
Figure 46: Monitoring computers displaying received data .....	72
Figure 47: Daily variations of wheat grain storage temperature in the greenhouse .....	74
Figure 48: Daily variation of wheat storage moisture content in the greenhouse .....	74
Figure 49: Storage temperature as the function of wheat storage moisture content .....	75
Figure 50: The effect of temperature on the dielectric constant of .....	76
Figure 51: The relationship of wheat storage moisture content and .....	76
Figure 52: Wheat storage moisture content as the function of dielectric constant .....	77
Figure 53: Wheat storage moisture content as the function refractivity .....	77
Figure 54: Daily variations of wheat grain storage temperature in the open air area .....	78
Figure 55: Daily variation of wheat storage moisture content in the open air area .....	78
Figure 56: Wheat storage temperature as the function of moisture content .....	81
Figure 57: Effect of temperature on the dielectric constant during wheat storage .....	82
Figure 58: The effect of moisture content on the dielectric constant .....	88
Figure 59: Moisture content as the function of refractivity .....	89
Figure 60: Daily variation of hard wheat storage temperature .....	90
Figure 61: Model relative error in capturing temperature data .....	90
Figure 62: Daily variation of hard wheat storage moisture content.....	93
Figure 63: Model relative error in capturing moisture content data .....	93
Figure 64: Daily variation of soft wheat storage temperature .....	94
Figure 65: Model relative error in capturing temperature data .....	94
Figure 66: Model relative error in capturing moisture content data .....	95

Figure 67: Model relative error in capturing moisture content data .....	95
Figure 68: Prediction of hard wheat condition during storage .....	96
Figure 69: Prediction of soft wheat condition during storage .....	96
Figure 70: Prediction of hard wheat condition during storage .....	97
Figure 71: Prediction of soft wheat condition during storage .....	97
Figure 72: Measured against forecasted states during storage.....	98
Figure 73: Measured against forecasted states during storage .....	98
Figure 74: Measured against forecasted states during storage .....	99
Figure 75: Measured against forecasted states during storage .....	99
Figure 76: Measured against forecasted states during storage .....	100
Figure 77: Measured against forecasted states during storage .....	100
Figure 78: Measured against forecasted states during storage .....	101
Figure 79: Measured against forecasted states during storage .....	101

## LIST OF APPENDICES

Appendix I: Grain Storage Condition Monitoring Model Flowchart .....	138
Appendix II: Training Data for Grain Storage Condition Forecasting Method.....	139
Appendix III: Sample Hard Wheat Grain Storage Condition Data in the Greenhouse .....	139
Appendix IV: Sample Soft Wheat Grain Storage Condition Data in the Greenhouse .....	140
Appendix V: Data from hard wheat storage layers in the greenhouse .....	140
Appendix VI: Data from soft wheat storage layers in the greenhouse .....	141
Appendix VII: Forecasted data from hard wheat storage in the greenhouse.....	141
Appendix VIII: Forecasted data from soft wheat storage in the greenhouse.....	142



## CHAPTER ONE

### GENERAL INTRODUCTION

#### 1.0 Introduction

Monitoring of grain crops in storage facility benefits both society and research. Proper monitoring not only provides storage forecasts, useful for a wide range of agricultural sector applications, but it also can be used to better realize the responses of grain crops to ecological changes and thereby informs research, planning, management and assessment of the impact of condition variation in the storage facilities. The study by Chakraborty and Newton (2011) reported that the key important climate conditions that affect grain quality in the storage are temperature and moisture contents. These motivate mold growth, insect activity and production of mycotoxin in the storage. The mycotoxin is mainly produced by species of the fusarium, aspergillus or penicillium genus. It also belongs to a chemical group of secondary fungal metabolites. Likewise, it mostly depends on the environmental factors such as drought, relative humidity and temperature. It always occurs when crops are still in the field and during their improper storage as reported by Monbaliu *et al.* (2009), Richard (2007) and Streit *et al.* (2012). Cereals are infected by mycotoxin once its toxicants such as fumonisin, zearalenone, mycelium, and trichothecene are increasing during growth and storage (Chulze, 2010; Jouany, 2007). When the mycotoxin is consumed by humans or animals above a certain level, it will cause mycotoxicosis reaction. Its symptoms are fertility problems, reduction of body weight, and immune suppression. It increases vulnerability to parasites which may lead to diseases and death (Binder, 2007; Bryden, 2012). Hence, mycotoxin infection makes grains not safe for food and animal feed. Consumption of high amount of aflatoxin causes aflatoxicosis that can result in severe illness and death, normally through liver cirrhosis (Tefera *et al.*, 2011). Therefore, grain crops need to be properly monitored to avoid deterioration of their quality (Gonzales *et al.*, 2009a) for safe use.

Recently, wireless communication technologies have become very important with many advantages to the society. To date sensing technology plays an important role in monitoring and control applications where human interaction is impossible (Hariprabha and Vasantharathna, 2014). Current development of wireless communication technology such as ZigBee, Bluetooth, and Wi-Fi, the sensors are no longer confined to be connected to a wired network. It has led to many benefits such as reduced cost due to decreased amount of required cables, and machine monitoring which cannot be monitored with a wired technology

e.g. rotating machinery, temporary applications, and mobile applications (Östmark, 2004). Using wireless technology requires a number of sensors to be deployed for collecting magnetic information. Each sensor node as shown in Fig. 1 by Wang *et al.* (2014) takes the reading of less value and all sensors can predict any event configured into them.

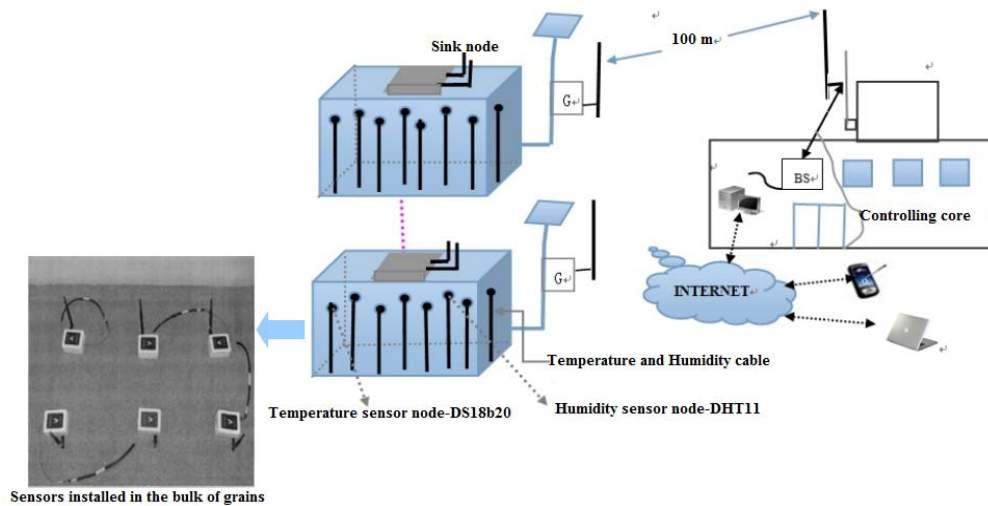

Figure 1: Overall layout of granary monitoring

Due these capabilities and advantages, it has been adopted in agricultural products management, such as in drying grains (Nelson and Trabelsi, 2008). The adoption became possible with the use of several methods such as moisture, temperature, and relative humidity sensors. However, these methods are not capable of measuring temperature and moisture from a lot of grains at a time that has made it costly (Nath and Ramanathan, 2017). These methods are also designed to use probes as shown in Fig 1.1 which damage the physical properties of grains (Deshpande and Shaligram, 2012b; Wang *et al.*, 2014).

Various techniques regarding grain crops monitoring have been presented by several researchers. The study by Dong *et al.* (2014) reported a granary temperature and humidity monitoring system based on ZigBee wireless network in China. The study aimed at cutting down the cost of granary management and maintenance. Wang *et al.* (2014) presented a wireless sensor granary monitoring system. In that study, DS18B20 and DHT11 sensors were used to measure granary temperature and humidity respectively. Alarm mechanism was used to notify the variation. In Tanzania, the study conducted in Kondo, Mbulu, Babati, Kilosa,

and Kongwa districts showed that most of the storages are still done traditionally. The storages are constructed of mud and cow dung (Makalle, 2012; Tefera and Abass, 2012). Grain dryness monitoring is emphasized by visual assumptions, which in turn might cause high grain storage losses. The farmers also apply insecticides to keep the grains in good quality, that later harm human health once consumed (Gastón *et al.*, 2009; Gonzales *et al.*, 2009a; Iguaz *et al.*, 2004; Maier *et al.*, 2010).

Due to the inefficient existing wheat storage monitoring methods, this research was conducted to find out the alternative solution to enable detection and forecasting of temperature and moisture content through wireless communication technology, which is currently used in a wide range of wheat grain monitoring.

### **1.1 Problem Statement**

The current situation in Tanzania indicates inadequate grain storage because of improper monitoring and control of environmental conditions such as temperature and moisture content in the storage facilities as their variations that affect the quality of the grains. Inefficient storage affects the quality of seeds, which results to poor capability of germination and consumption (Sawant *et al.*, 2012). To avoid this, most of the farmers end up selling their grains soon after they harvest. This necessitates the farmers to buy new seeds every time they want to plant, at an expensive price just a few months after harvest, falling in a poverty trap (Tefera *et al.*, 2011).

Due to the incapability of the traditional grain storage monitoring approach of detecting the temperature and moisture content from the grain that leads to a possibility of a portion of the bulk of grains to be affected. Therefore, this study focused on the wireless model for effective detection of temperature and moisture content from a large amount of grains as well as forecasting of daily grain conditions in storage for monitoring purposes.

## **1.2 Objectives**

### **1.2.1 Main Objective**

The main objective of this study is to design the model for monitoring grain crops in the storage facilities through wireless communication technology. Specific objectives of this study are as follows:

### **1.2.2 Specific Objective**

This study analyzes previous studies on design of monitoring techniques for grain crops in the storage facilities in order to derive an appropriate approach for the wireless grain storage monitoring model. Then, the proposals and solutions for monitoring the storage conditions are addressed. More specifically, the study attempts to answer the following objectives with research questions in section 1.3:

- i. To analyze the existing technique for monitoring grain crops in storage facility
- ii. To design and simulate the model for detecting and forecasting wheat grain storage condition (temperature and moisture content) using wireless technology
- iii. To evaluate the performance of the proposed method in terms of robustness and reliability in real time.

## **1.3 Research Questions**

- i. What are the factors that influence the design of the model for monitoring the grain crops in the storage facilities?
- ii. What are the new factors to be incorporated in designing the effective model for detecting and forecasting the wheat storage condition?
- iii. Can the proposed technology accurately detect and predict storage weather parameters and conditions in real time?

## **1.4 Significance of the Research**

This study adds more knowledge to the existing technologies for monitoring wheat storage conditions using wireless technology and improves detection of temperature, moisture content and forecasting. The proposed method will provide a practical solution to a wide range of real time applications in monitoring the storage condition of several cereal crops.

The research results also will be a useful input to farmers, crop business enterprises and other stakeholders such as the Government, donors and investors in determining the grain storage of the farmers and crop business/sowing operations. It will also enable farmers and crop business stakeholders to determine the appropriate grain storage for their operations.

Furthermore, these results would add knowledge in the field of telecommunication into agriculture extending the existing technologies.

### **1.5 Research Methodology**

In order to answer the research questions outlined previously, intensive systematic literature review was first undertaken for meticulous understanding of the factors that affect grain storage condition and the reasons that govern their behavior, to identify where and how they can be determined. The study considered wheat crop as the prime grain in this work, since it is the most important staple food crop that contributes more calories and proteins to the world diet than any other cereal crops. It is also a good source of dietary fiber that prevents and treats digestive disorders as reported by Pawan *et al.* (2011). Furthermore, the method used in this study for investigating the outlined research questions, looks at the potential relationships between variables including moisture content, temperature and electromagnetic fields (dielectric properties of wheat grains) with respect to the storage environment. Thereafter, the method for capturing data (moisture content and temperature) from the stored grains was designed based on the Debye and radio refractivity techniques. It also considered the safe and future state of the storage by applying the Hidden Markov model technique. What's more, it was designed to transmit the captured data from the storage facility to the monitoring station wirelessly based on the ZigBee technology. Then, the performance evaluation of the proposed method was conducted to check its viability in real environment. This evaluation was carried out in both controlled and non-controlled environments. Consequently, the formulated model was made up of only two intensive operating sub-models as illustrated in Fig. 2.

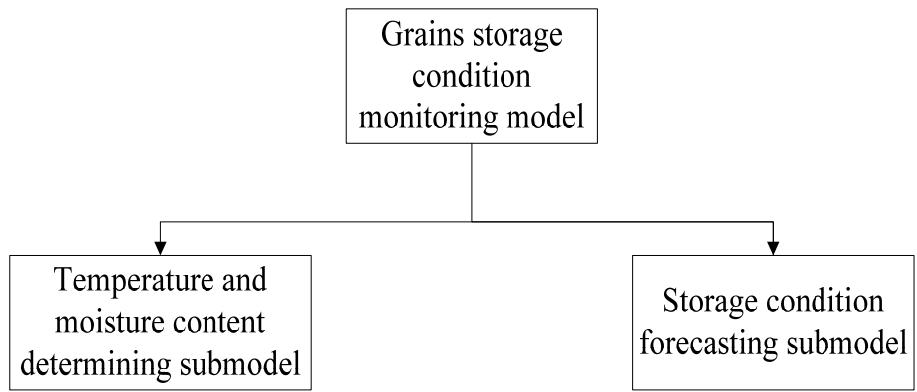

Figure 2: Proposed model summary

## CHAPTER TWO

### <sup>1</sup>An Overview of Electromagnetic radiation in Grain Crops

#### **Abstract**

Electromagnetic radiation is becoming an effective tool in diverse technologies and scientific fields. A comprehensive knowledge of electromagnetic radiation with grain crops is the promising potential for effective exploitation of electromagnetic fields. However, its role in controlling of the bulk of grain in storage is still not vigorously investigated. This paper reviews the application of electromagnetic fields for cereal crops processing providing a brief introduction on the basic laws of electromagnetic radiation and knowledge of electromagnetic fields with wheat grains. It also discusses application of electromagnetic heating and sensing in cereal grain processing operations such drying, disinfestations and storage and the factors that affect the dielectric properties of the cereal grains in the context of samples and process parameters. It also provides the recommendations for future research to achieve the accurate measurements of moisture content and temperature for proper wheat grains storage.

#### **2.0 Introduction**

Electromagnetic energy is an important element in agricultural products processing. When this energy moves in the form of electromagnetic waves away from the source is called electromagnetic radiation and is categorized according to frequency waves such as radio waves, microwave, infrared, visible light, ultraviolet radiation, X-rays and gamma rays. It is usually applied to food products for the purpose of keeping their quality.

In developing countries, farmers spread their crop grains to dry under the sun, which often requires longer duration for the product to attain safe moisture level. The grains are usually spread out on the ground, or rock surfaces or on nylons till the products are dry. Farmers sometimes stack the food products, bringing grains under cover and drying them over the fire (Bankole and Adebajo, 2004; Wambugu *et al.*, 2009). Another method is to pass the air through the grain mass in storage with the support of natural air, fans and suction methods. Moisture is absorbed and carried away from the grain mass (Khatchatourian and Oliveira, 2006; Pierson *et al.*, 2009). Modern technology for drying the grains is by applying

---

<sup>1</sup> Published by Johevajile K. Mazima, Shubi F. Kaijage, Johnson I. Agbinya and Emmanuel C. Manasseh in Food Science and Technology: An International Journal, 2016, Volume 1, Issue 1, page 21-32

electromagnetic heating. Once it is applied to food products, the thermal heat energy is transferred in the form of electromagnetic waves and absorbed by the food products. Temperature distribution inside food products heated with microwave is determined by both thermal properties of the products and the distribution of the absorbed microwave energy (Datta, 2001; Oliveira and Franca, 2002; Rahman, 2007; Ramaswamy and Tang, 2008). For several years, electromagnetic field has been primarily applied in agricultural products processing with little practical application in monitoring the grain bulk from moisture content and temperature. The frequency of the electromagnetic field is used to measure just surface layers not the whole product (Kaatze and Hübner, 2010). Grain temperature and moisture content are considered to be the principal factors for safe storage of grains, if they are well controlled (Nelson, 2008; Uddin *et al.*, 2006). However, recently significant research efforts have been made in the vicinity of sensing moisture and temperature of grain samples in the laboratories using electromagnetic principles (Trabelsi *et al.*, 2008; Rai *et al.*, 2007; Tang and Wang, 2007; Gowen *et al.*, 2010). Therefore, this article explores the existing technologies to provide insights for the relationship between dielectric properties and large mass of grains in storage. This is for the purpose of sensing moisture content and temperature from the grain bulk. The review also covers other applications such as drying, disinfestations and pasteurization of cereal grains.

## 2.1 Electromagnetic Radiation Basic Laws

Electromagnetic energy radiation is described by the equations with five components,  $B$ ,  $E$ ,  $D$ ,  $\rho$  and  $J$ .  $H$  and  $B$  denote magnetic field in A/m and magnetic flux density in Vs/m<sup>2</sup> respectively.  $E$  and  $D$  denote the electric field in V/m and electric displacement in As/m<sup>2</sup> respectively.  $J$  and  $\rho$  denote current density in A/m<sup>2</sup> and charge density in As/m<sup>3</sup> of the medium respectively. The equations with these components are the Maxwell's equations that govern the behaviour of the electromagnetic fields. In dielectric medium, there are neither free charge (free currents) nor bound charge density. There is also no magnetization current density. However, there is a polarization current due to time variation of the induced dipole moment per unit volume. The polarization current (Kirsch and Hettlich, 2014; Müller, 2013) is given as:

$$\mathbf{j} = \frac{\partial \mathbf{P}}{\partial t} \quad (1)$$

In these media the conductivity of the medium is zero ( $\sigma = 0$ ) and there is no charge in it

The reflective index  $n$  of the medium is expressed as:



$$\mathbf{n} = \sqrt{\epsilon} \quad (2)$$

Electromagnetic radiation is described by Maxwell's equations with corresponding boundary conditions. These equations are the same as those in free space as expressed by the laws below (Komarov *et al.*, 2005):

$$\text{Faraday's law in point form:} \quad \nabla \times \mathbf{E} = -\frac{\partial \mathbf{H}}{\partial t} \quad (3)$$

$$\text{Ampere's law in point form:} \quad \nabla \times \mathbf{H} = \mathbf{J} + \frac{\partial \mathbf{D}}{\partial t} \quad (4)$$

$$\text{Gauss' law for the electric field:} \quad \nabla \cdot \mathbf{D} = 0 \quad (5)$$

$$\text{Gauss' law for the magnetic field:} \quad \nabla \cdot \mathbf{B} = 0 \quad (6)$$

## 2.2 Electromagnetic Fields with Cereal Crops

When electromagnetic wave is incident on a matter with different electromagnetic properties from the first medium, partial reflection occurs at the boundary between the two media. Some fractions of the incident wave may be transmitted and the rest may be absorbed as shown in Fig. 3 by Hou *et al.* (2016). If the impedances of the two media are almost equal most of energy is transmitted and the reflected signal is relatively small. Conversely, if the impedances differ greatly the transmitted signal is small and the reflected one is relatively large. The particular type of interaction depends on the energy of the wave and the structure of the matter. The interaction with electromagnetic energy is always influenced by the intrinsic properties of the matter (dielectric properties) (Govindarajan *et al.*, 2005; Komarov *et al.*, 2005; Lin and Michaelson, 2013). The dielectric properties (dielectric constant  $\epsilon'$  and the dielectric loss factor  $\epsilon''$ ) of the relative complex permittivity (Nelson, 2008) are the main parameters that provide information about how materials interact with electromagnetic energy (Bhargava *et al.*, 2014). The relative complex permittivity is expressed as:

$$\epsilon = \epsilon' - j\epsilon'' \quad (7)$$

Where,  $\epsilon'$  is the dielectric constant that describes the ability of a material to store energy,  $\epsilon''$  dielectric loss factor that describes the ability of a material to dissipate energy. Electromagnetic wave diminishes by  $1/e$  after passing a certain distance (penetration depth,  $d_p$ ) through a material (Awuah *et al.*, 2014):

$$d_p = \frac{c}{2\pi f \sqrt{2\epsilon' \left[ 1 + \left( \frac{\epsilon''}{\epsilon'} \right)^2 - 1 \right]}} \quad (8)$$

where,  $c$  is the speed of light in free space, and  $e$  is equal to 2.7183

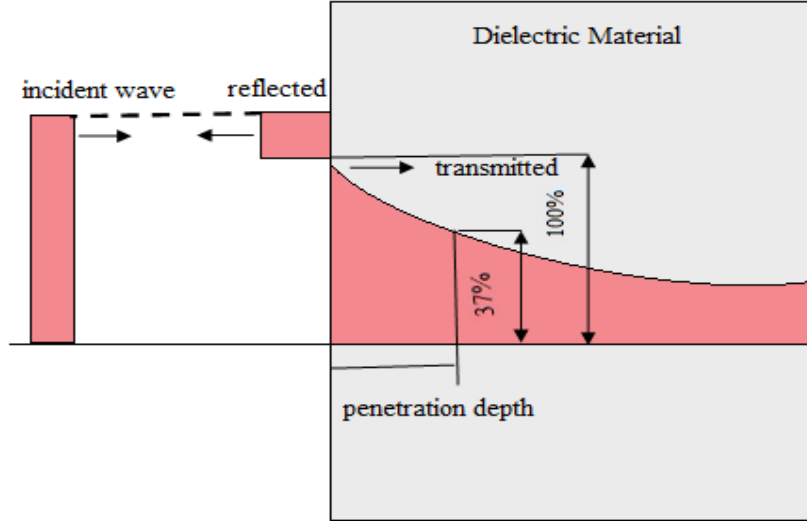

Figure 3: When electromagnetic strikes with high loss factor

Biological materials such as Living organisms and agricultural products are dielectrics though they conduct electric currents to some degree. The electrical nature of these materials is described by their dielectric properties. These properties influence the distribution of electromagnetic fields and currents, and determine the behaviour of the materials in electric fields (Nelson, 2010). A bulk of grains represents a disperse system of dielectric medium formed by dispersive particles and air spaces between them. Every particle (grain) has the porous structure and also can be considered as a complex disperse system. It is formed by organic substance of inhomogeneous composition and density, with air micro capillaries in it and with micro particles of absorbed water (Serdyuk, 2008). The mathematical formulation developed by Debye is used to describe the electrical properties of materials. It is given as (Jones *et al.*, 2006; Nelson and Trabelsi, 2012):

$$\varepsilon' = \varepsilon_{\infty} + \frac{\varepsilon_s - \varepsilon_{\infty}}{1 + \omega^2 \tau^2} \quad (9)$$

$$\varepsilon'' = \frac{(\varepsilon_s - \varepsilon_{\infty}) \omega \tau}{1 + \omega^2 \tau^2} \quad (10)$$

where  $\tau$  is the relaxation time in seconds where dipoles trail off to random orientation when the electric field is removed,  $\varepsilon_s$  is the static dielectric constant at zero frequency,  $\varepsilon_{\infty}$  is the dielectric constant at high frequency where orientation does not contribute to polarization, and  $\omega$  is the angular frequency. Since, the grain bulk is considered as dispersive medium with

a combination of grains and air. Various dielectric mixture equations are used to calculate the dielectric properties of an air particle mixture (Alfaifi *et al.*, 2014) as described below:

a. Landau and Lifshitz, Looyenga equation

$$(\varepsilon)^{1/3} = V_1(\varepsilon_1)^{1/3} - V_2(\varepsilon_2)^{1/3} \quad (11)$$

b. Complex Refractive Index mixture equation

$$(\varepsilon)^{1/2} = V_1(\varepsilon_1)^{1/2} - V_2(\varepsilon_2)^{1/2} \quad (12)$$

Where,  $\varepsilon$  is the complex permittivity of the mixture medium,  $\varepsilon_1$  is the complex permittivity of air that is  $1-j0$ ,  $\varepsilon_2$  is the complex permittivity of the particle medium,  $v_1$  and  $v_2$  are the volume fractions of the mixture, air and the bulk particle medium respectively.  $\rho$  is the air particle mixture density and  $\rho_2$  is the particle material density. The total volume fraction is expressed as (Alfaifi *et al.*, 2014):

$$v_1 + v_2 = 1 \quad (13)$$

$$v_2 = \frac{\rho}{\rho_2} \quad (14)$$

## 2.3 Electrical Properties of Grain Crops

Dielectric Properties of grains are affected by various factors such as moisture content, temperature, bulk density, frequency and storage time. In cereal crops, the amount of water in the material is generally a dominant factor (Moura *et al.*, 2016; Nelson and Trabelsi, 2012; Yunyang *et al.*, 2013).

### 2.3.1 Temperature Effect

The effect of temperature has been studied by a number of researchers to investigate its effect on the dielectric properties of cereal grains. The study by Zhu *et al.* (2013) presented the influence of temperature on dielectric properties of loose fill buckwheat seed samples in the range of 1 to 1000 kHz, temperatures from 5°C to 40°C and moisture content from 11.1% to 17.1%. The authors found that dielectric constant and dielectric loss factor both increased with increasing temperature as shown in Fig. 4 and 5. Moreover, the study by Shrestha and Baik (2015) reported the temperature dependence of dielectric permittivity of grains at radio frequencies. The dielectric permittivity of bulk wheat samples at various temperatures was

measured. The dielectric constant of the wheat increased roughly linearly with temperature, while the loss factor increased nonlinearly with temperature.

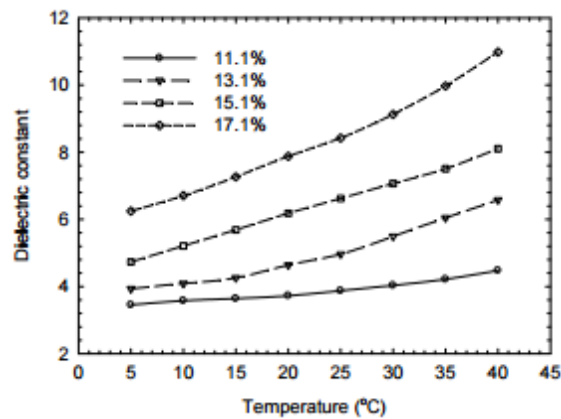

Figure 4: Variation of dielectric constant of loose fill buckwheat with temperature at different moisture content

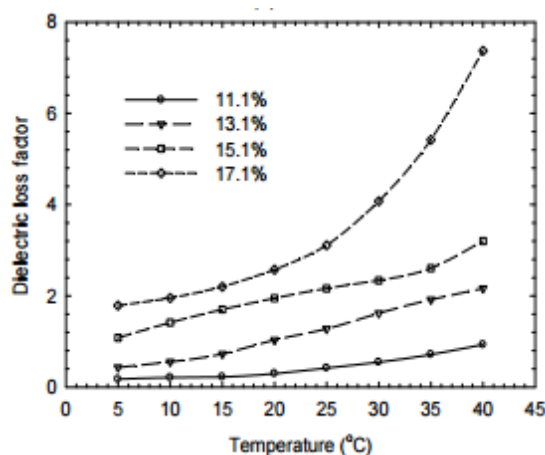

Figure 5: Variation of loss factor of loose fill buckwheat with temperature at different moisture content

### 2.3.2 Frequency Effect

The dielectric properties of most materials such as cereal grains vary considerably with the frequency of the electromagnetic fields. The polarization is the key factor that contributes to the frequency dependence of the dielectric (Nelson and Trabelsi, 2012) as shown in Fig. 6 and 7. The study taken at the range of 10 MHz to 1.8 GHz reported that the dielectric properties of hard red winter wheat decreased consistently with increasing frequency (Nelson and Trabelsi, 2009). The dielectric constant of grains (Ismail and Asri, 2014) increases with

increasing frequency while the loss factor may either increase or decrease with increasing frequency as shown in Table 1. It was also reported by Trabelsi and Nelson (2012) that dielectric properties of cereal grains such as wheat, corn, barley, oats, and grain sorghum were measured at 23°C. The technique used was a free-space transmission at the range of 5 to 15 GHz. It was found that the dielectric constants of all grains decreased with increasing frequency and increased with increasing moisture content. Loss factors varied slightly with increasing frequency, remaining almost constant for barley and oats, decreasing slightly with increasing frequency for wheat and grain sorghum, and increasing slightly with increasing frequency for corn.

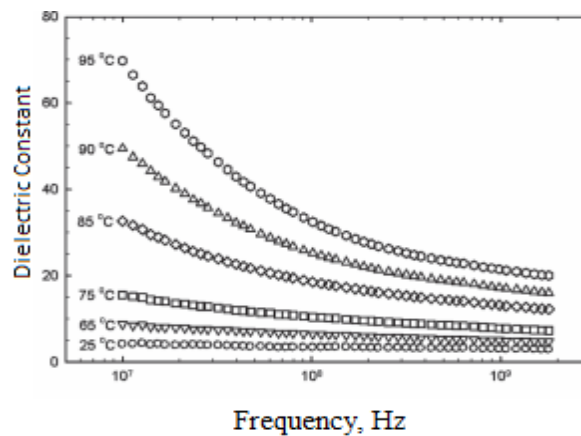

Figure 6: Dielectric constant of hard red winter wheat as the function of frequency at different temperature

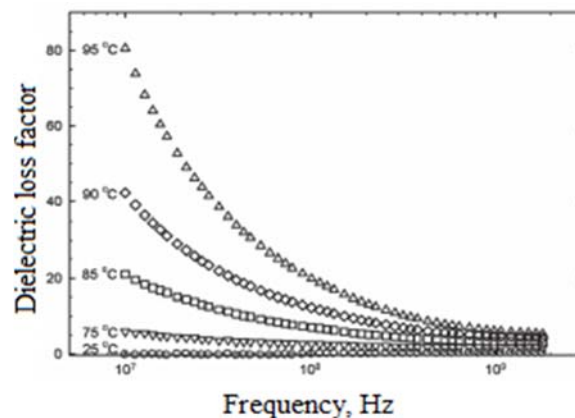

Figure 7: Loss factor of hard red winter wheat as the function of frequency at different temperature

### 2.3.3 Moisture Content Effect

Various studies investigated that moisture content has major effects on most properties of crops. One of these properties which are much affected by moisture content is the dielectric constant of grains and seeds. High moisture level causes the total polarization of the grains

and seeds to increase (Sacilik and Colak, 2010; Soltani and Alimardani, 2013a; Thakur *et al.*, 2011). In the study by Soltani and Alimardani (2013a), the dielectric constant of wheat and millet was investigated as the function of moisture content and frequency. Polynomial and homographic regression was used to analyze the relationship of dielectric constant and moisture content. The results showed that the dielectric constant increased homographically with increasing of moisture content. Table 1 shows that the moisture content (Ismail and Asri, 2014) influences the dielectric properties of grains at any frequency. The dielectric loss factor is found to be less predictable than the dielectric constant and may either increase or decrease with moisture content, depending upon the particular range of moisture content. The other study by Sacilik and Colak (2010) presented the determination of dielectric properties of corn seeds to investigate the effects of moisture content, bulk density and frequency. It was found that the moisture content was the most major factor affecting the dielectric properties of corn seeds as demonstrated in Fig. 8.

Table 1: Dielectric Properties of Grains at different moisture contents and frequencies

Grain	MC (%)	Frequency (GHz)					
		10		40		1	
Grain	MC (%)	$\epsilon'$	$\epsilon''$	$\epsilon'$	$\epsilon''$	$\epsilon'$	$\epsilon''$
Barley, spring	32	32	0.25	3	0.03		
Rye, winter	4			4	0.52		
Oats, spring	10.7	2.8	0.2			2.2	0.18
Sorghum, spring	11.4	4.2	0.38			2.9	0.29
Wheat	12.5					2.89	0.35
Oats	10.7					2.12	0.16
Sorghum	11.4					2.81	0.34

Source: Ismail and Asri (2014)

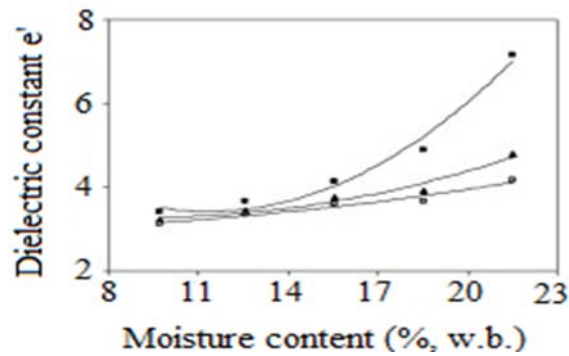

Figure 8: Variation of dielectric constant of corn with moisture content

### 2.3.4 Bulk Density Effect

The density (mass per unit volume) has the effect on the dielectric properties because these properties depend on the amount of mass interacting with the electromagnetic fields. The size of particles in the mixture when gets much smaller than the wavelength of the waves, the effective permittivity depends only on the shape of the particles and is independent of their size (Guo *et al.*, 2013; Nelson and Trabelsi, 2012). The granular density of seed of grain is reported to covers a range 0.5-0.85 cm<sup>3</sup>, where 1 cm<sup>3</sup> contains about 30-35 seeds (Castrejón *et al.*, 2015). The study by Moura *et al.* (2016) reported the bulk density of grain sorghum hybrid (BRS 308, BRS 310, BRS 655 and CMSXS 769) that was experimentally determined with respect to the dielectric properties and moisture content in the range of frequency from 75 – 5 MHz using a chondrometer. The bulk density was in the range of 575 -819 kg/m<sup>3</sup> and moisture content in 7 – 23%. The experimental results proved that the bulk density decreased with increasing moisture content for cereal grains. Furthermore, it was also presented that the dielectric constant and loss factor of wheat straw depended on the bulk density, temperature and moisture content and the frequency in the range of 1 to 1000 kHz. The bulk density was in the range of 47.3 - 108.1 kg/m<sup>3</sup>, temperature in 5°C - 40°C and moisture content in 10% - 20%. Both dielectric constant and loss factor increased with increasing bulk density, temperature and moisture content (Guo *et al.*, 2013).

### **2.3.5 Storage Time Effect**

The storage time can change the dielectric properties of grains. If the storage is humid, the grains can easily absorb moisture. Also when it is dry, they lose moisture. Their dielectric properties can decrease with the increase storage time due to the decline of moisture content. Once moisture is reduced with time, electrical conductivity increases while Ph increases with increasing temperature (Ponomaryova, 2011). The study by Nagel and Börner (2010) reported the germination of seeds for five accessions per reproduction cycle which was found to decrease over storage time.

### **2.4 Electromagnetic Heating Effects on Cereal Crops**

Microwave Radio and Frequency energy are thermal in nature. Most crops that considered dielectric materials can have the same behavior (Das *et al.*, 2013). The study by Torrealba-Meléndez *et al.* (2015) presented microwave frequency use in the analysis of dielectric properties of grains for heating purpose. The free space transmission method was used to determine the properties at frequencies of 915, 2450 and 5800 MHz. It was found that both frequency and temperature increased as the penetration depth decreased for all samples except for barley. The other study by Zheng *et al.* (2016) presented the radio frequency of 27 MHz in a pilot-scale with 6 kW. The study analyzed the heating uniformity in corn samples with five moisture contents. It also used three plastic material containers, and developed a treatment procedure for a corn sample with the moisture content of 15.0% w.b. The authors found that only 7.5 min was needed to lift up the temperature of 3.0 kg corn grains from 25 °C to 70 °C using the RF method. Corn quality was not affected by the RF treatments even after the hastened storage. However, the effective and better environment for pasteurizing corns must be provided. Moreover, the radio frequency selective heating for disinfestations in grain storage was presented by Bijay and Baik (2013). The efficiency of method was evaluated using power factors and the rate of increase of temperature. It was found that a major effect on insect to wheat power absorption factor varied.

### **2.5 Electromagnetic Sensing Effects on Cereal Crops**

The study by Trabelsi *et al.* (2008) presented the development of a microwave sensor for sensing of moisture content in granular and particulate materials. It operates at a single frequency of 5.8 GHz in free space transmission. It was found that moisture content in wheat



and soybeans can be determined from a single moisture calibration equation. The authors also found that the technology was not costly and can be useful integration of microwave sensing technology in industries for granular and particulate materials such as food, and agriculture.

In addition, the analysis and optimal design of a multi-layered microstrip sensor of 9 GHz were presented. The study focused on measuring the moisture content of rice grain between 10% to 30% (wet basis). This study studied the optimal thickness of the protective layer for suitable sensitivity and the thickness of grain medium. The results indicated that the attenuation of the signal varied (Jafari *et al.*, 2010).

However, most applications are conducted in laboratories not for commercial or industry use (Hou *et al.*, 2016). Also, the maximum penetration depth by microwave frequency seemed to be lower than that by Radio frequency due to its short wavelength. RF treatment has deeper penetration than MW treatment. This penetration depth determines the size and shape of food products. RF can be used to treat the large bulk of material than Microwave. But, there is no limitation on the size and shape of products for microwave application, while RF needs to treat material with regular and simple shape. Microwave treatment also is so cheap. Moreover, when the size of particle is much smaller than the wavelength of the wave, the effective permittivity depends only on the shape of the particles and is independent of their size (Awuah *et al.*, 2014).

## **2.6 Conclusion**

The studies conducted in over the years have shown that the exposure on the use of electromagnetic radiation for food security is very important. Differences have been renowned in the issue of wave penetration depth through the bulk of grains between the radio and microwave frequencies. Essentially, the microwave penetration depth is not as good as radio frequency depth, but it does not consider the size and shape of grain products for radiation as in RF. This makes it better for almost all types of grain product processing. The use of electromagnetic radiation for moisture and temperature control in grains storage has several advantages:

- i. It is non destructive method that never affects the physical properties of wheat grains.

- ii. It can characterize the dielectric properties of wheat grains for the whole storage due to the intruders (variation of moisture content and temperature) with respect to the operating frequency.
- iii. The method can provide a safe ground for wheat grains storage against mycotoxin, insects and mold activities that cause the grain losses and degradation of grain quality.

Since, the moisture content and temperature control of large quantity of grains (wheat) has not been much explored. Therefore, extra investigations regarding electromagnetic radiation are still required for the successful applications of the wheat storage in future. Moisture and temperature controlled processes with respect to dielectric properties have to be considered for large quantity of wheat grains in storage. The spatial and temporal measurement method for wheat water and temperature monitoring must also be considered so that the safe grain storage condition is successfully achieved in regard with radiation depth through the wheat medium.

## CHAPTER THREE

### <sup>2</sup>Stochastic Modeling technology for Grain Crops Storage Application: Review

#### Abstract

Stochastic modeling is a key technique in event prediction and forecasting applications. Recently, stochastic models such as the Artificial Neural Network, Hidden Markov, and Markov Chain have received a significant attention in agricultural applications. These techniques are capable of predicting the actions for the better planning and management in various fields. This work comprehensively summarizes and compares their applications such as processing techniques, performance as well as their strengths and limitations with regard to event prediction and forecasting. The work ends with recommendations on the appropriate techniques for cereal grain storage application.

#### 3.0 Introduction

Stochastic modeling techniques have been the most significant in prediction and forecasting (Cioffi *et al.*, 2013; Xiong *et al.*, 2014; Isojunno and Miller, 2016). These techniques have been used for estimating the probability of outcomes to predict what conditions might be under different situations (Duan, 2015). Forecasting of unknown features depends on exploitation of these techniques. They largely contribute to better detection and prediction of data. Modeling techniques such as Artificial Neural Networks, Hidden Markov and Markov Chain Models have become increasingly important methods with the growth of complex computations (Silva *et al.*, 2011; Zhang, 2003). Today, we are faced with the crucial problem of inefficient detection and prediction of conditions (variations of moisture contents and temperature) over the entire grain bulk (Deshpande and Shaligram, 2012a) in the storage facility. The aim of this study is to suggest the best technique for forecasting the grain storage conditions under few given states.

#### 3.1 Literature review

Hidden Markov Model (HMM), Artificial Neural Networks (ANNs) and Markov Chains (MC) models are popular tools for modeling dependent random variables in diverse areas

---

<sup>2</sup> Published by Johevajile K. Mazima, Shubi F. Kaijage, Johnson I. Agbinya and Emmanuel C. Manasseh in International Journal of Artificial Intelligence and Applications, 2016, Volume 7, Issue 6, page 27-42

(Isojunno and Miller, 2016) such as speech processing and enhancement (Kato and Milner, 2014), audio segmentation (Bietti *et al.*, 2015), DNA recognition (Xiong *et al.*, 2014), fault (Wang *et al.*, 2016) and rainfall occurrence (Cioffi *et al.*, 2013). These are based on a stochastic process (Ramesh *et al.*, 2013) in which a chain produces an unobservable state that can be inferred only through another set of stochastic process. Previous studies on weather condition and crop activity show that forecasting using stochastic techniques is a highly researched area as shown in Table 2 to 3 though not enough has been done for crop grain storage. In Fig. 9 and 10, the frequency of publications in the area of weather condition and crop activity forecasting published between 2008 and 2016 respectively are demonstrated in this study.

### **3.1.1 Artificial Neural Networks (ANNs)**

For crop activities as demonstrated in Table 2, the study by Silva and Sonnadara (2013) presented a neural network approach in which the classification of rice varieties was estimated. An overall classification accuracy obtained was 92%. Wheat seeds classification using ANN was also estimated whereby the method was found to be effective for recognizing wheat varieties (Yasar *et al.*, 2016). A study by Zhou *et al.* (2012) showed that back propagation neural network (BPNN) provided more correct wheat classification at 90% than discriminant analysis which was at 83.33%. Furthermore, Abdullah and Quteishat (2015) illustrated how Multilayer perceptron back propagation with image processing algorithm gave higher wheat seeds classification accuracy which was at 95%. It was presented in (Safa *et al.*, 2015) that ANN approach was capable of predicting wheat production under different conditions and farming systems using direct and indirect technical factors such as nitrogen consumption, total tractor horsepower per hectare, wheat area, number of passes of sprayer, irrigation frequency and fungicide consumption. Moreover, three terms ANN back propagation network was proposed as a predicting tool for moisture content on maize. The model outweighed the two terms back propagation with the proportional factor which increased the convergence speed and reduced learning stalls (Abdulkadir *et al.*, 2012). The study Chayjan and Esna-Ashari (2010) presented the artificial neural network method in which the equilibrium moisture content of maize was predicted. Maize needed less energy at a higher moisture content (above 11% dry basis.) for drying and storing but at a lower moisture content more energy was needed. Artificial Neural Network analysis was also carried to predict the extent of shelled corn shrinkage. The method was found to be most

appropriate for prediction capability of shrinkage (Momenzadeh and Zomorodian, 2011). It was also reported by Al-Mahasneh *et al.* (2014) that generic approach for collective prediction of moisture sorption isotherms (MSI) for 12 cereals and 5 legumes using artificial neural networks was an effective, reliable and fast method for the collective prediction of MSIs for several grains and legumes simultaneously.

For weather condition as shown in Table 2, a study by Abhishek *et al.* (2012) reported the prediction of rainfall over Udupi District of Karnataka in India through artificial neural network. The method used three layered networks of different number of hidden neurons. In the study by El-Shafie *et al.* (2011) rainfall prediction suggested that the ANN model could be an important tool for local rain forecasting although it cannot replace the traditional forecasters' experience, but setting off it with superfluous information. It was also reported in (Ramana *et al.*, 2013) that rainfall prediction by combining wavelet technique with ANN gave high accuracy. Moreover, a study by Lohani *et al.* (2011) presented that ANN with linear transfer function (LTF), and fuzzy rule-based techniques was developed for the prediction of rainfall runoff for Narmada catchment up to Manot gauging site. Another study by Wu and Chau (2011) presented the rainfall runoff modeling using Modular ANN with singular spectrum analysis. In the study by Kueh and Kuok. (2016), an ANN approach to forecasting future precipitation was proposed. It was done through spatial downscaling and constructing new intensity duration-frequency (IDF) curves with climate change into consideration using a temporal downscaling method. It was reported in (Partal *et al.*, 2015) that neural network algorithms with wavelet transformation for daily precipitation predictions provided significant advantages for estimation process.

### **3.1.2 Markov Chain (MC)**

This section has focused merely on the forecasting studies using Markov chain model conducted between 2008 and 2016. In a work by Osman *et al.* (2015), MC was used to predict the crop grown on a field when the crops grown in the previous 3–5 years are known. The obtained results showed that the proposed approach was able to predict the crop type of each field before the beginning of the crop season with accuracy of 60%, which was better than the results obtained with approaches based on remote sensing imagery. Non-stationary Markov chain with logistic regression was also used to model dynamics of crop rotation (Troffaes and Paton, 2013). Some of studies presented the weather forecasting as shown in

Table 2. Among them include: estimation of the rainfall sequences during the rainy season in Kurdufan (Adam, 2016), rainfall prediction at the Daspalla Region in Odisha, Eastern India (Mandal *et al.*, 2015) for crop planning, daily rainfall occurrence forecasting in Peninsular Malaysia (Deni *et al.*, 2009), the rainfall estimation during monsoon season over major station in Gangetic West Bengal (Dastidar *et al.*, 2010) and a stochastic generator of monthly rainfall series in Tunisia (Safouane *et al.*, 2016). In the study by Wang *et al.* (2007), MC with weights was applied to predict Standardized Precipitation Index (SPI) drought intensity by using standardized self-coefficients as weights. However, the forecasting ability was weak when there was a sharp change or an increase in drought intensity. Analysis of hydrological drought characteristics showed that the expected frequency of drought occurrence was higher for smaller time scales (i.e., 3-month and 6-month) (Tabari *et al.*, 2015). Moreover, other works presented the wet and dry patterns of daily precipitation in Colombo (Sonnadara and Jayewardene, 2015). The method also can be used to investigate the return periods of long wet and dry spells. However, the accuracy of modeling wet spells found to be high compared to dry spells. Markov chain was also used to know the dry and wet spell distribution at Varanasi in Uttar Pradesh whereby a week period was considered as the optimum length of time (Singh *et al.*, 2014). The study by Vamitha *et al.* (2012) presented daily temperature prediction from correlated categorical data sequence in Taipei, Taiwan. The proposed method gave higher average forecasting accuracy.

### **3.1.3 Hidden Markov Model (HMM)**

For crop activities as shown in Table 3, the study by Lu and Qin. (2010) found that the rate for single insect with normal pattern was about 98%, while for lateral position single insect was about 87%.

In this work (Shen *et al.*, 2012), a general framework of HMMs based corn progress percentage estimation method was also presented. The results demonstrated the feasibility of proposed solutions on corn progress percentage estimation in the state-level. Moreover, the optimum growth states and atmospheric conditions were determined using the Viterbi algorithm in HMM. For weather condition as demonstrated in Table 2, the study by Pal *et al.* (2015) presented modeling of winter rainfall occurrence using the hidden Markov model. The hidden states were assumed to be an unknown random function of slowly varying climatic modulation of the winter jet stream and moisture transport dynamics. In the study by

Tan *et al.* (2016), modeling of a homogeneous hidden Markov model on the northeast rainfall monsoon using 40 rainfall stations in Peninsular, Malaysia for the period of 1975 to 2008 was also presented. The model assessed the behaviour of rainfall characteristics with large scale atmospheric circulation. It was reported in (Greene *et al.*, 2011) that non-homogeneous HMM was utilized to investigate potential changes in Indian monsoon summer rainfall, comparing with the 2070–2099 period with the second half of the twentieth century. The persistence level of Kuantan daily rainfall prediction was reported in (Yusof *et al.*, 2015). It was done using the hybrid of autoregressive fractional integrated moving average (ARFIMA) and HMM. Moreover, it was presented in (Mallya *et al.*, 2012) that the hidden Markov model was used for analyzing the spatiotemporal characterization of droughts at different severities. Another work by Mallya *et al.* (2012) presented the development of the hidden Markov model for assessing the drought characteristics in India using monthly precipitation and stream flow data. Moreover, Homogenous HMMs were also developed for forecasting droughts using the Standardized Precipitation Index, SPI, at short-medium term (Khadr, 2016). Furthermore, the work by Shena *et al.* (2011) reported a constrained HMM for evaluating a session of precipitation series. The method was capable of checking the quality of precipitation series instead of manual way.

Table 2: Key points of survey on weather condition forecasting techniques

<b>Main focus</b>	<b>Method</b>	<b>References</b>
Rainfall runoff modeling	ANN	(Lohani <i>et al.</i> , 2011; Wu and Chau, 2011)
Precipitation downscaling forecasting	ANN	(Kueh and Kuok, 2016)
Daily precipitation predictions	ANN	(Partal <i>et al.</i> , 2015)
Rainfall prediction	ANN	(Abhishek <i>et al.</i> , 2012; El-Shafie <i>et al.</i> , 2011; Ramana <i>et al.</i> , 2013)
Rainfall forecasting	MC	(Adam, 2016; Dastidar <i>et al.</i> , 2010; Deni <i>et al.</i> , 2009; Mandal <i>et al.</i> , 2015; Safouane <i>et al.</i> , 2016)
Drought occurrence prediction	MC	(Tabari <i>et al.</i> , 2015; Wang <i>et al.</i> , 2007)
Dry and wet spell distribution	MC	(Singh <i>et al.</i> , 2014)
Description of wet and dry patterns of weather	MC	(Sonnadara and Jayewardene, 2015)
Temperature prediction	MC	(Vamitha <i>et al.</i> , 2012)
Rainfall modeling	HMM	(Greene <i>et al.</i> , 2011; Pal <i>et al.</i> , 2015; Tan <i>et al.</i> , 2016; Yusof <i>et al.</i> , 2015)
Drought forecasting	HMM	(Khadr, 2016; Mallya <i>et al.</i> , 2012; Tripathi <i>et al.</i> , 2012)
Anomaly detection of precipitation series	HMM	(Shena <i>et al.</i> , 2011)



Table 3: Key points of survey on crop activities forecasting techniques

Main Focus	Method	References
Predicting wheat production	ANN	(Safa <i>et al.</i> , 2015)
Classification of Rice Grains	ANN	(Silva and Sonna-dara, 2013)
Identification of Stored Grain Age	ANN	(Zhou <i>et al.</i> , 2012)
Moisture Prediction in Maize	ANN	(Abdulkadir <i>et al.</i> , 2012; Chayjan and Esna-Ashari, 2010)
Determining moisture sorption isotherms of cereal grains and legumes	ANN	(Al-Mahasneh <i>et al.</i> , 2014)
Predicting the capability Shelled corn shrinkage	ANN	(Momenzadeh and Zomorodian, 2011)
Wheat Seeds Classification	ANN	(Abdullah and Quteishat, 2015; Yasar <i>et al.</i> , 2016)
Predicting the crop type of each field for crop rotation	MC	(Osman <i>et al.</i> , 2015)
Crop rotation modeling	MC	(Troffaes and Paton, 2013)
Stored grain insect Image processing	HMM	(Lu and Qin, 2010)
Estimation of Corn Progress Stages	HMM	(Shen <i>et al.</i> , 2012)

### 3.1.4 Strengths and limitation of forecasting techniques

A number of strengths and limitations of forecasting techniques have been identified in this work as summarized in Table 4 (Ayer *et al.*, 2010; Bassi *et al.*, 2007; Bhardwaj *et al.*, 2013; Bolch *et al.*, 2006; Chen *et al.*, 2012; Ching *et al.*, 2008; Degirmenci, 2014; Elmolla *et al.*, 2010; Figueroa-Angulo *et al.*, 2015; Gaikwad *et al.*, 2010; Johnson and Willsky, 2013; Lampros *et al.*, 2007; Liu, 2010; Marwala *et al.*, 2006; Navarro and Bennun, 2014; Netzer *et al.*, 2008; Pradhan and Lee, 2010; Ross, 2014; Skalny and Krajc, 2013; Yang *et al.*, 2007). Markov Chain Model (especially first order Markov Chain) with some of the data is insufficient to estimate reliable probability. Because it may not be possible to observe sufficient transitions from a given transient set of states to a closed state where this transition is dependent on a rare climatic event, the value of this parameter is of vital importance in the dynamics of the community. Also, validation of the Markov model depends on predictions of

system behavior over time, and it is; therefore, frequently difficult, and may even be impossible for really long period of time. Hidden Markov Model is flexible with fewer computations compared to artificial neural network model (Koehler *et al.*, 2015; Sadhu *et al.*, 2016). However, Hidden Markov Model algorithm (Jiang and Liu, 2016; Trentin and Gori, 2001) (forward backward or Viterbi) presents poor discriminative power because it bases on the Maximum Likelihood (ML) criterion, which is itself non-discriminative. The technique (Hassan and Nath, 2005) is explainable and has solid statistical foundation. It shows potentials for time series prediction.

Table 4: Strengths and limitations of modeling techniques

	<b>ANN</b>	<b>HMM</b>	<b>MC</b>
<b>Strengths</b>	Independent on the statistical distribution Nonlinearity  Discriminative  Rich in complex computation	Performs linear relationship  Dynamic relationship Powerful optimization algorithms (EM) Computational intractability inferring hidden state form observation  Deals well with sequential structures	Effective in modeling time series  Effective in modeling categorical data sequences  Solves several linear programming problems  Evaluates system reliability well
<b>Limitations</b>	Lack of interpretability Lack of a set of methods for optimizing the network structure  Unable for linear computation Cannot perform better for independent stochastic event  Over training of network  Extrapolation error A great computation burden over-fitting  Black box in nature Unclear relationships between the outcome and the predictors	Inefficient and difficult to interpret for many states  Fully-connected transition diagram can lead to severe over fitting  Lack of global context for modeling  Require the initial assumption for the statistical distributions  The number of hidden states must be set a priori so that model complexity is not inferred from data in a bayesian way	Does not predict the future from the observed events  Computational limitations  Slow convergence rates and very slow  The amount of computations increases rapidly with the amount of states  Model is often not structurally similar to the physical or logical organization of the system

## 3.2 Forecasting Techniques

### 3.2.1 Artificial Neural Networks Model (ANN)

Artificial Neural Network model is the mathematical tool which is used to simulate and solve complex problems. It is based on the powerful thought ability of the human brain. It is applied to various applications such as industry, health, electronics, finance, chemistry,

statistics, agriculture, automotive and cognitive sciences. Artificial Neural Networks are described by their modular structure, learning capability, prediction performance, and internal non-linearity. As human brain, they also has neurons with many synapses as reported by Krenker *et al.* (2011) in Fig. 9. Its neuron has the simple model with three functions such as multiplication, summation, and activation. Each input of a neuron is multiplied by the weight at the entrance. Then, it sums up all weighted inputs and bias. At last, the mathematical model determines the activation level of the neuron using the transfer function as shown in Fig. 10 as presented by Krenker *et al.* (2011). This is done once the activation level exceeds the threshold value (Erkaymaz *et al.*, 2014; Were *et al.*, 2015).

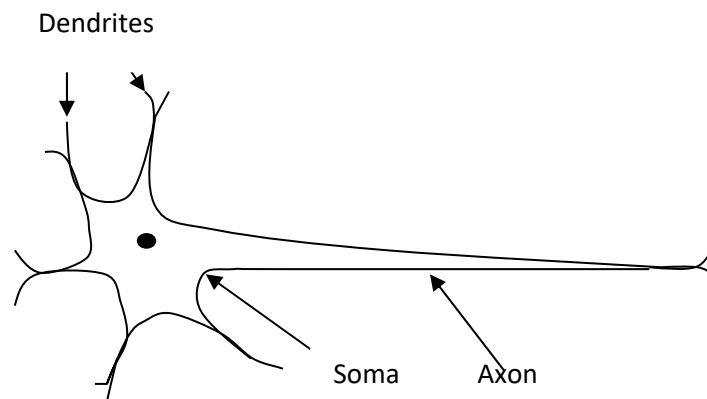

Figure 9: Biology neuron

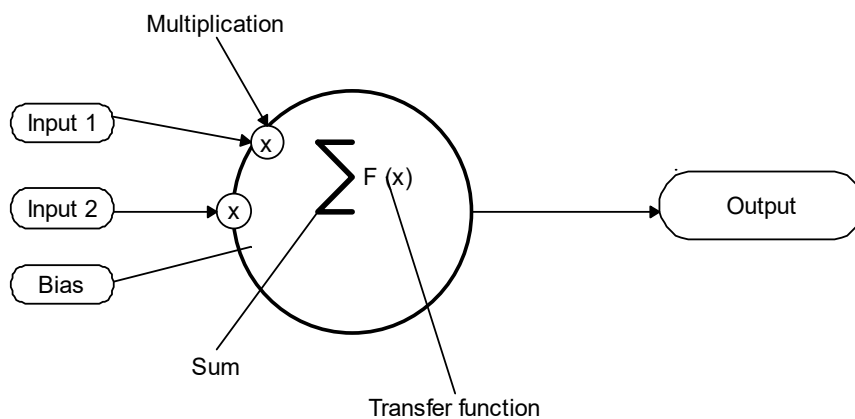

Figure 10: Artificial neuron

Artificial Neural Network Model has architecture (Economou, 2010) which consists of three neuron layers such as input, hidden and output layers as shown in Fig. 11. The first layer has

input neurons that send information through synapses to the second layer of neurons. Then, they pass through more synapses to the third layer of output neurons (Akinci, 2015; Khashei and Bijari, 2010).

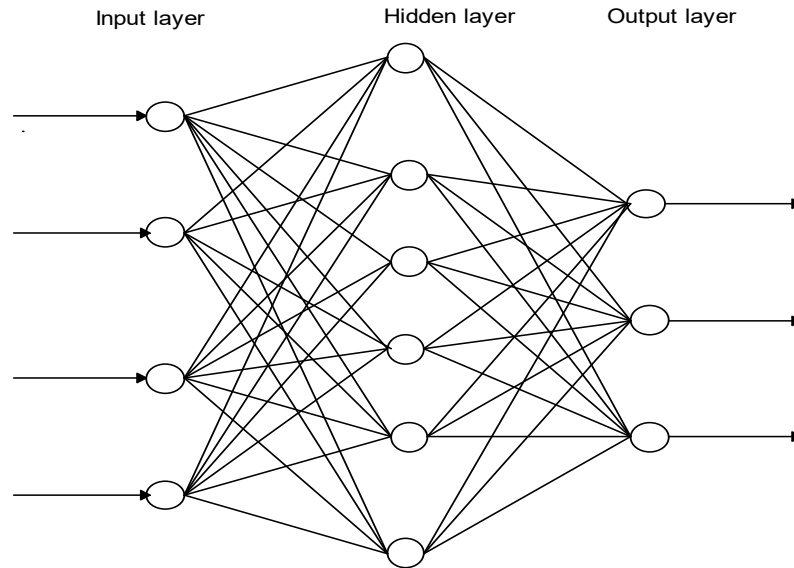

Figure 11: ANN structure

### 3.2.2 Markov Chain Model (MC)

A Markov chain is a mathematical model of a random observable fact with time that the past affects the future only through the present. The time can be discrete or continuous. It works basing on Markov property. It has a finite set of possible states and transitions among them. These are governed by a set of conditional probabilities of the next state given the present one (Jamal *et al.*, 2015; Striccoli *et al.*, 2015).

**Markov Property:** The Markov property states that the conditional probability distribution for the system at the next step depends only on the current state of the system, and not the state of the system at previous steps.

A Markov chain is defined by a transition probability parameter ( $a_{ij}$ ) associated with each transition (arrow) and determines the probability of a certain state ( $S_j$ ) following another state ( $S_i$ ). The state probabilities are well defined below (Simon *et al.*, 2011; Zheng *et al.*, 2015): It has a finite set of states,  $S_1, S_2 \dots S_N$ , a set of transition probabilities:

$$a_{ij} = P(q_{t+1} = S_j | q_t = S_i) \quad (15)$$

The initial state probability distribution is given as:

$$\pi_i = P(q_0 = S_i) \quad (16)$$

### 3.2.3 Hidden Markov Model (HMM)

Hidden Markov Model is an extension of the Markov Chain. It is the simplest dynamic bayesian distribution over sequences of observations. It is described as a 5-tuple  $\lambda = (q, \Sigma, \pi, A, B)$ . The states  $q$  are hidden and probabilities  $A$  are state transition probabilities that indicate the chance that a certain state changes might occur. Probabilities  $\pi$  are the initial state transition probabilities. Each state has a set of possible emissions  $\Sigma$ . Probabilities  $B$  are observation probabilities for the emissions. HMM applies the Markovian property. In every state, a Markov Chain can be observed directly. But sometimes there is a sequence of a state that wants to be known but cannot be observed directly but through the observable state as shown in Fig. 12 by Mackworth (2010). That is why it is called the Hidden Markov Model (Coviello *et al.*, 2014; Kohlschein, 2006).

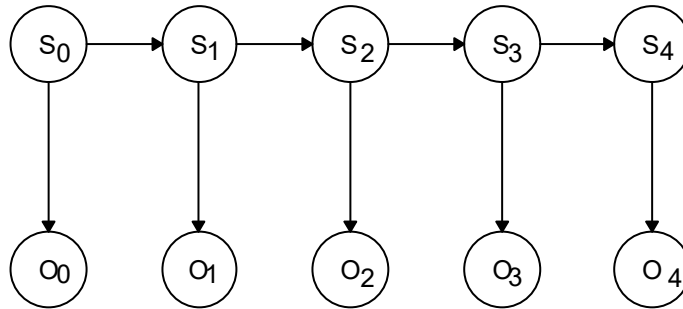

Figure 12: HMM topology

The HMM states (Dymarski, 2011; Tumilaar *et al.*, 2015) are described as:

$N$  is the number of hidden states in the model. The individual states are denoted as:

$$S = \{s_1, s_2, \dots, s_N\} \quad (17)$$

This is done at the length  $t$  as  $Q_t$ .

$M$  is the number of distinct observation symbol per hidden state. The individual symbols are denoted as:

$$V = \{v_1, v_2, \dots, v_M\} \quad (18)$$

It is also done at the length t as  $O_t$ .

The state transition probability matrix is described as:

$$[A]_{ij} = \{a\}_{ij} \quad (19)$$

$$\text{Whereas, } a_{ij} = P(Q_{t+1} = s_j | Q_t = s_i), 1 \leq i, j \leq N \quad (20)$$

The observation symbol probability in hidden state j is also described as:

$$[B]_{jk} = \{b_j(v_k)\} \quad (21)$$

$$\text{Where, } b_j(v_k) = P(O_t = v_k | Q_t = s_j)$$

$$1 \leq j \leq N, 1 \leq k \leq M \quad (22)$$

The initial state distribution is given as:

$$\Pi = \{\pi_i\} \quad (23)$$

$$\text{Where, } \pi_i = P(Q_1 = s_i) 1 \leq i \leq N \quad (24)$$

Once the HMM is given appropriate values of N, M, A, B, and  $\pi$ , it can be used as a generator to a given observation sequence:

$$O = \{O_1 O_2 \dots O_T\} \quad (25)$$

Where, T is the number of observations in the sequence. For simplicity, using the compact notation (Coviello *et al.*, 2014; Kabir *et al.*, 2016; Kohlschein, 2006):

$$\lambda = (A, B, \pi) \quad (26)$$

### **i. HMM Main Problem Solving Steps**

The Hidden Markov Model architecture usually is automated with integrated stochastic processes using solving techniques such as evolution, decoding and Learning.

#### **A. Evolution**

This is an algorithm process in HMM with a sequence of observations,  $P(O | \lambda)$ . The probability of the observation sequence given a model can be computed (Coviello *et al.*, 2014; Kabir *et al.*, 2016). One of the efficient algorithms for evolution solution is the Forward algorithm. In evolution if the process in the HMM is a first order Markov Chain, the probabilities of the system in particular state  $s(t)$  at time  $t$  depends on its state at  $s(t-1)$  (Adeyanju *et al.*, 2016; Coviello *et al.*, 2014; Kabir *et al.*, 2016; Kohlschein, 2006). The probability of the HMM being in state  $s_j$  at time  $t$  having generated the first  $t$  emission that is the partial probability  $\alpha_j(t)$ :

$$\alpha_j(t) = \begin{cases} 0 & , t = 0 \text{ and } j \neq \text{initialstate} \\ 1 & , t = 0 \text{ and } j = \text{initialstate} \\ [\sum_i \alpha_i(t-1)a_{ij}]b_{jk}v(t), & \text{Otherwise} \end{cases} \quad (27)$$

## B. Decoding

This is the algorithm that produces the most probable sequence of hidden states given some observations (Dymarski, 2011; Mendez *et al.*, 2010). It applies Viterbi algorithm, which is also a trellis algorithm. It is very similar to the forward algorithm, except that the transition probabilities are maximized at each step instead of being summed. It is a simple and efficient decoding technique.

## C. Learning

Learning is the process that calculates the Markov model on state transition and emission matrices that have generated a sequence of observations. The process has supervised and unsupervised trainings. If the training contains both the inputs and outputs of the process, then supervised training can be performed by equating inputs to observations and outputs to states. But if only the inputs are provided in the training data, then unsupervised training is used to guess a model that may have produced those observations (Coviello *et al.*, 2014; Das and Hasegawa-Johnson, 2015; Siu *et al.*, 2014).

The Baum Welch algorithm is the mostly used method in the learning technique. This is also known as forward backward algorithm. It gives the probabilities that the model is in state  $s_i(t)$  as (Kohlschein, 2006). These probabilities are the partial in equation (27) and backward probabilities in equation (28):



$$\beta_i(t) = \begin{cases} 0 & , s_i(t) \neq s_0(t) \text{ and } t = T \\ 1 & , s_i(t) = s_0(t) \text{ and } t = T \\ \sum_i \beta_j(t+1) a_{ij} b_{jk} v(t+1), & \text{Otherwise} \end{cases} \quad (28)$$

Since,  $\alpha_i(t)$  and  $\beta_i(t)$  are just estimates for the calculation of an improved of these estimates the auxiliary  $\gamma_{ij}(t)$  quantity is introduced (Kabir *et al.*, 2016; Kohlschein, 2006):

$$\gamma_{ij}(t) = \frac{\alpha_i(t-1) a_{ij} b_{jk} \beta_j(t)}{p(v^T | \lambda)} \quad (29)$$

Using the auxiliary quantity, an estimated version  $\hat{a}_{ij}$  of  $a_{ij}$  can now be calculated by Adeyanju *et al.* (2016), Kabir *et al.* (2016) and Kohlschein, 2006):

$$\hat{a}_{ij} = \frac{\sum_{t=1}^T \gamma_{ij}(t)}{\sum_{t=1}^T \sum_k \gamma_{ik}(t)} \quad (30)$$

Similarly, an estimated version  $\hat{b}_{jk}$  of  $b_{jk}$  can be given as (Adeyanju *et al.*, 2016; Kabir *et al.*, 2016; Kohlschein, 2006):

$$\hat{b}_{jk} = \frac{\sum_{t=1}^T \sum_{l \neq j} \gamma_{jl}(t)}{\sum_{t=1}^T \sum_l \gamma_{jl}(t)} \quad (31)$$

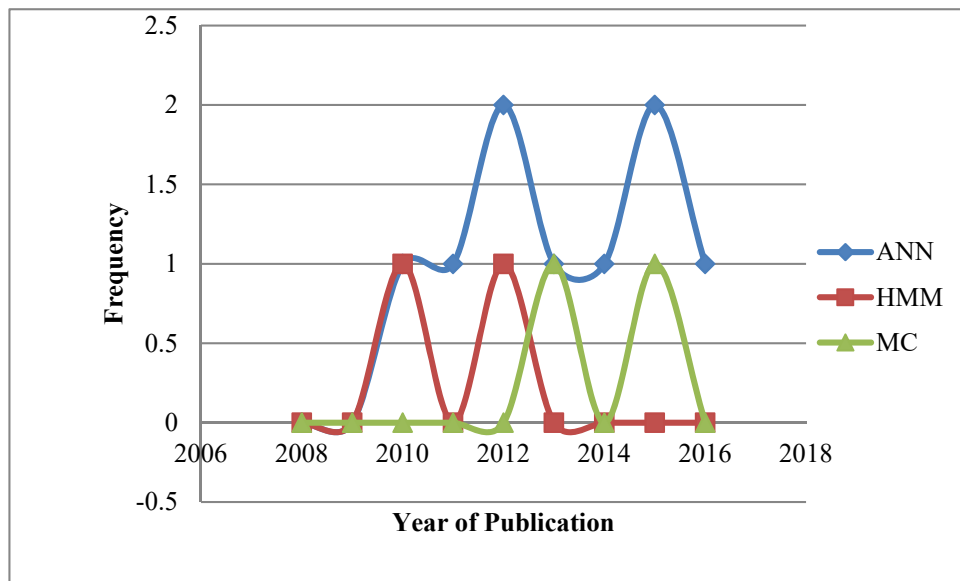

Figure 13: Studies of modeling techniques on crop

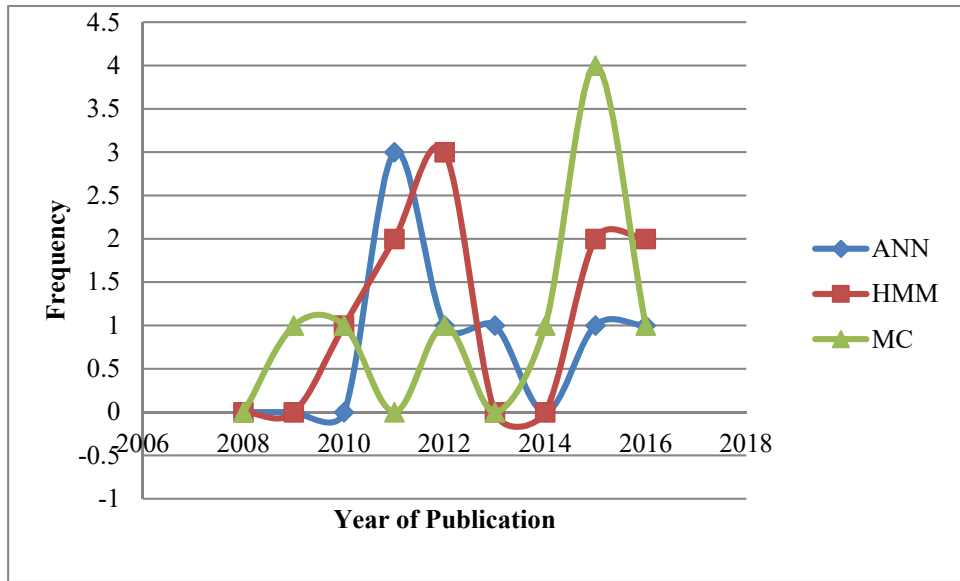

Figure 14: Studies on weather condition

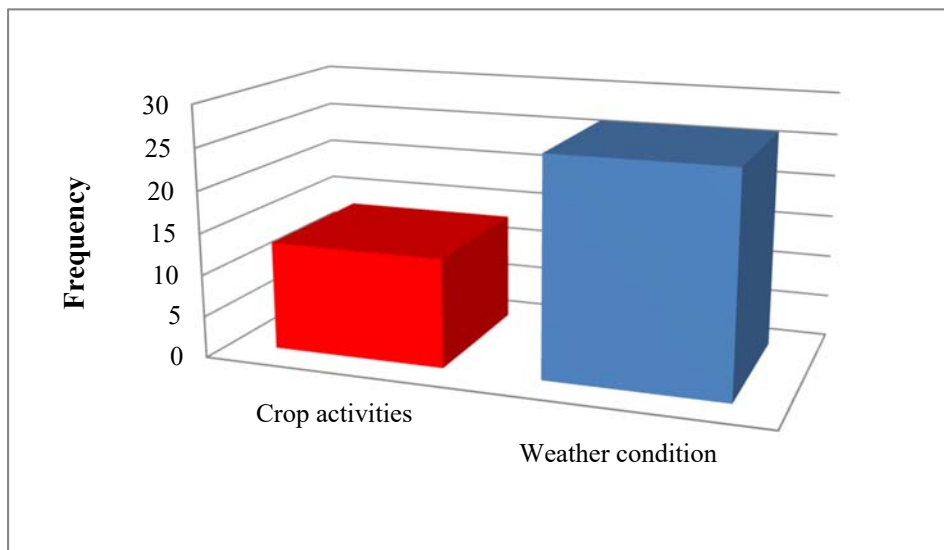

Figure 15: Activities forecasted using modeling techniques between 2008 and 2016

### 3.3 Discussion and Conclusion

From literature and as reviewed in this work, the weather condition forecasting dominates in crop activities as demonstrated in Fig. 13, 14 and 15. The findings indicate positivity of the stochastic models in environment monitoring. Table 4 shows that Artificial Neural Network is applied only to non-linearly separable classes. Moreover, it has the black box nature that

causes greater computation burden on the hardware infrastructure available for the analysis which is a great disadvantage to many systems. Nonetheless, it has a superior capability over other models in complex computations and convergence. Based on the reviewed results in Table 4, Markov Chain does not allow prediction of the hidden states since it is limited to emission probability. But, Hidden Markov Model allows different types of states to be defined such as hidden states and observation states in connection with the normal and emission probabilities. It always models conditional dependencies of predicts (hidden states) from observed states. Therefore, the sequence of states visited is hidden. Unlike in MC, there is no longer a one to one correspondence between states and output symbols. Besides in the HMM, the same symbol may be emitted by more than one state and a state can emit more than one symbol.

The published papers with applications of ANN, HMM, and MC for weather condition and crop activities were reviewed in this work. All these technologies proved to have given solutions for crop planning, weather prediction, moisture detection, temperature estimation, as well as crops and seeds classification. But, the reviewed studies have confirmed that the condition forecasting of crop storage is not yet seriously researched. For this reason, these modeling techniques can be introduced in grain storage application whereby the storage condition must be forecasted basing on the variations of temperature and moisture contents. ANN and HMM have enormous advantages over other models, like MC for their ability to learn the environment. Hence they are better models. Either ANN or HMM or both are highly recommended to be applied in grain storage condition forecasting. Since the HMM is a less computational and flexible model, it might be the best option for the grain storage condition when few states are needed to be computed.

## CHAPTER FOUR

### The Designed Method for Determining Temperature and Moisture Contents in the Wheat Grain Storage using Electromagnetic Properties

#### Abstract

Appropriate cereal grain storage contributes highly to food security. In order to keep the stored grains safe such as wheat, the variation of temperature and moisture contents must be monitored. The aim of this study is to propose the novel design for examining the condition of grain bulk in the storage facility using electromagnetic properties. It considers the electromagnetic fields, radio refractivity and isotherms for determining this variation. Electrical properties of wheat varieties are compared and evaluated using Debye model. The modified radio refractive index quantity is the modified method to relate the interaction of electromagnetic radiation with temperature and moisture content through the wheat grain bulk. Moreover, moisture content is evaluated by Modified Henderson for the isotherm properties for the purpose of fitting the designed model to various wheat types. The results of the study show that all types of wheat respond well with their dielectric properties in relation to the refractivity with the variation of temperature and moisture contents when in storage. The method can be potentially giving the positive impact in real environment applications and would be more beneficial if extended to other types of cereal crops.

#### 4.0 Introduction

Wheat is the one of the cereal grains that is an important food crops for daily survival of billions of people around the world. Other cereals are rice, maize, sorghum and millet (Awika, 2011). The quality of these grains are affected by many factors during storage such as temperature, moisture content, insects, microorganisms, mites, moulds, rodents, birds, storage time, inter-granular gas composition, dockage, granary structure, seed maturity and geographical location. But, the most vital aspects for keeping the quality of the grain storage are grain moisture content and temperature. Their variation motivates the mold and insect activities in the storage. Out of the grain safety point, mould starts to grow in that way affecting the grain quality (Gonzales *et al.*, 2009b; Rajarammanna *et al.*, 2010).

Moisture content and temperature in grains can be measured by relating them with electrical properties of the grains (Soltani and Alimardani, 2013b). Agricultural products absorb more

electromagnetic energy once the temperature increases due to the increase in their electrical properties in certain frequency (Sosa-Morales *et al.*, 2010). Part of agricultural products at higher temperature tends to absorb more energy for speeding up the temperature variations (Hou *et al.*, 2016). Due to the significance of food security, numerous studies have been conducted to maintain the grain environmental condition better by applying dielectric and isothermal methods.

#### **4.1 Methods for Measuring Climatic Parameters in Cereal Crops**

##### **4.1.1 Measurement by Dielectric Measuring Methods**

The variation of moisture and temperature of agricultural products is detected by relating their dielectric properties, since these properties are highly affected by this variation (Nelson and Trabelsi, 2012). A study by Chenchen (2013) presented a moisture meter that was designed for the purpose of measuring moisture content of coarse cereals. This technology used the DC charge/discharge circuit, digital temperature sensor DS18B20 and equal-arm bridge circuit to detect the values of capacitance, temperature and bulk density of coarse cereals. Millet was measured to study the influence of moisture content, temperature and bulk density on capacitance with the self-made moisture meter. It was found that the measurement precision for moisture content was  $\pm 0.5\%$  and the response time was less than 3 seconds when the moisture content in wet basis was within 11%-19% and in temperature of 5°C -40°C. On the other hand, a prototype of multi-grain moisture meter with the frequency of 230 kHz was presented and was based on the capacitive sensing technique. Its objective was to characterize the dielectric properties of a variety of Indian whole cereal grains with moisture content (MC) ranging from 7 to 35% (wet basis). It measured the MC of cereal grains due to variation of dielectric medium resulting in capacitance variation. The coefficient of correlation between MC and capacitance variation was high and measurement accuracy was found to be 1% (Thakur *et al.*, 2014). Furthermore, Yang *et al.* (2010) presented the plane polar plate probe for measuring grain moisture content. The technology used the finite element to study the capacitance and electric field of the probe. The authors found that the highest error in taking moisture of the sensor was  $\pm 1.5\%$  while the moisture and temperature measurements were from 6% to 36% and -10°C to 80°C. This technology promised the optimization of measurement accuracy and reducing the problem of installation of the plane polar probe. Majewska *et al.* (2008) also presented the determination of electric properties of wheat grain in dependence, moisture, kernel features and frequency. It used the Hewlett Packard 4263B

meter to analyze the electric properties of grain at the moisture content range of 11% to 15%. It was found that the most significant association appeared between kernel and electric properties of wheat grain at 15% moisture. Moreover, Soltani and Alimardani (2011) reported a cylindrical capacitor that measured dielectric constant of grain seeds to predict the moisture content. Alteration in dielectric constant of corn and lentil was examined as a function of moisture content. The results indicated that moisture content highly depended on the dielectric constant at all frequencies. Moreover, the study by Funk *et al.* (2007) presented a Unified Grain Moisture Algorithm based on measurements of the real part of the complex permittivity and the frequency value of 149 MHz was set to give a peak value as a gain. Its purpose was to allow various moisture meter models to give corresponding moisture predictions without calibration development. It was found that the overall standard deviation of divergence was 0.34% moisture. However, the offset and slope errors were not totally removed by a simple standardization of the one grain type between the two test cells for all grain types. Below 0°C, a simple moisture independent function was not efficient than quadratic and linear moisture dependent temperature correction functions.

#### **4.1.2 Measurement by Isothermal Measuring Methods**

Moisture content has been also predicted from temperature and relative humidity based on equilibrium moisture content (EMC). The EMC models which have been used in this prediction some are the Modified Henderson, Chung-Pfost and Oswin. However, the quasi-static thermodynamic conditions somehow limit their operations (Uddin *et al.*, 2006). The purpose of using EMC is to estimate the moisture absorption and desorption. Since the grain safe storage needs the moisture absorption in grains to be avoided, EMC equations for predicting the relationship between the relative humidity and moisture content of grains in storage is very important (Jinshui, 2009). The various researchers who have been conducting some studies on this matter are described below:

The determination of moisture desorption of medium grain rice was presented by Iguaz and Virseda (2007) and was done using static gravimetric method. Moreover, data fitting was done by the modified Chung Pfost, modified Henderson model, GAB, Oswin and modified Halsey models with nonlinear regression analysis. The results showed that the moisture isotherms produced the sigmoid shape which in turn indicated the obvious effect of temperature. The authors also found that the modified Henderson and modified Chung Pfost

models produced the good results for desorption moisture isotherms of rough rice, while modified GAB produced the best. However, modified Halsey and Oswin models were not appropriate at all drying temperatures. Another study by Raji and Ojediran (2011) presented the determination of millets' moisture sorption at temperature range of 30°C to 70°C and water activity range of 0.07 to 0.98 through utilizing static gravimetric method. The result indicated that as the temperature increased the moisture sorption isotherms of millets decreased; their hysteresis loop size also increased and exhibited type II trend according of BET categorization. Data fitting was done by the modified Henderson model, GAB, Oswin and modified Halsey models. The fitting results revealed that findings were well acceptable, but only modified Oswin model provided best results for the whole set of data (Raji and Ojediran, 2011). The determination of Greek durum wheat semolina' moisture isotherms which was done using the static gravimetric and Novasina hygrometric methods showed that at constant temperature both water activity and moisture content increased. This implied that there was a typical temperature effect on sorption. At lower temperatures, higher water uptake was revealed in accordance with the theory of physical sorption. The sorption models such as GAB, Henderson, Freundlich, Chung Pfof, Halsey and Oswin models were used for describing the sorption of wheat. It was revealed that sorption isotherms of durum wheat semolina were of the characteristic sigmoid shape (BET type II) (Pollatos *et al.*, 2013). Furthermore, the investigation of the moisture sorption on the Chinese wheat types was presented by Xingjun *et al.* (2011). The study used the static gravimetric tool for the analysis at different temperatures and relative humidity. The authors reported that hysteresis effect loop appeared between desorption and adsorption isotherms. The sorption of wheat showed that at constant relative humidity decreased as temperature increased. The Modified Chung-Pfof, Strohman-Yoerger, Modified BET, Modified-Henderson, Modified Oswin and Chen-Clayton models were used to describe wheat sorption. The findings indicated that Modified-Henderson, Modified BET, Modified-Oswin and Modified-Chung-Pfof models were efficient at different relative humidity ranges.

The objective of this study is to design the method capable of determining the moisture contents and temperature using electromagnetic properties from the grain bulk in the grain storage facility. Thus in the design, it is necessary to consider the possible variations of dielectric properties, refractive index with frequency and bulk densities caused by temperature and moisture contents changes.

## 4.2 Methodology

The study proposes a design for monitoring the stored grain crops' condition utilizing wireless technology. The technology in Fig. 16 is a non-invasive that is capable of monitoring and forecasting the grain storage condition. A non-invasive part utilizes the electric field frequency for determining both moisture contents and temperature from the stored bulk of wheat grains basing on Debye model, modified refractivity and modified Henderson equation.

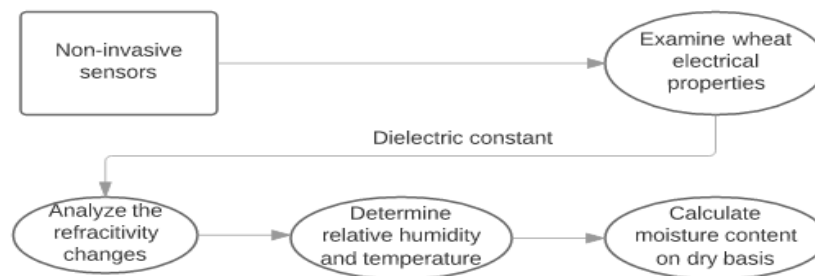

Figure 16: Moisture content and temperature determination method layout

The non-invasive part assumes the changes in the refractive index from the air through the wheat grain bulk that curl the path of the electromagnetic signal. Since the refractive index is related to the dielectric permittivity of a material as reported by Othman *et al.* (2011), then the relationship is taken into account by equation (2). It is given that the dielectric properties are the attribute of the materials which are poor conductors of electricity, and wheat medium is the one of these materials. This study applies equation (9) to model the dielectric permittivity of wheat medium, where  $\epsilon_{\infty}$  and  $\epsilon_s$  are the final and the static (initial) dielectric constants of wheat respectively,  $\tau$  is the relaxation time and  $\omega$  is the angular frequency. Within the initial and current final dielectric constants of wheat grains, any change in the storage can be decided. This leads to the change in refractive index. Due to this assimilation, the refractive index function leads to weather determination of the grain storage. As a result of this behaviour, the function of refractive index is expressed in equation (33).

Since, the numerical value of refractive index of wheat medium is considered to be larger than one, the atmospheric refractivity  $N$  is modified to (air-wheat refractivity)  $N_a$  with multiplier of constant  $c = 1000$ . Since refractive index of wheat is larger than 1, the multiplier constant  $c$  is obtained so that refractivity through wheat medium is able to display small



changes happening in the storage due to the influence of weather condition. Hence, new modified refractive index  $Na$  within the wheat medium is obtained as the product of the function of refractive index and the multiplier as described below:

$$Na = F(n)c \quad (32)$$

Whereby equation (32) is based on the function of the refractive index as described below:

$$F(n) = \Delta f \quad (33)$$

It further adds up to the new radio refractivity equation with the emphasis that relative humidity is the function of the new refractivity, temperature and pressure within the grain storage.

$$H = f(T_0, Na, P_0, P_s) \quad (34)$$

Where,  $T_0$  is the grain storage temperature in K,  $P_0$  storage vapour pressure in hPa and  $P_s$  is the saturation vapour pressure in hPa.

$$T_0 = (T_1 - \Delta) + k_n \quad (35)$$

Where,  $T_1$  is the ambient temperature in K,  $\Delta$  is the ratio of pressure difference and density of wheat grains with respect to their specific heat capacity while  $k_n$  is the temperature normalizing constant.

$$H = \frac{(Na - 77.6 \frac{P_0}{T_0}) T_0^2}{3.37 \times 10^5 P_s} \quad (36)$$

Considering the relative humidity (water activity) with radio refractivity of the wheat grain bulk, the moisture content (dry basis) is determined by modified Henderson equation with some constants as illustrated in Table 5 (Uddin *et al.*, 2006) as:

$$MC = 0.01 \left( \frac{\ln(1-H)}{-K(t+D)} \right)^{1/N} \quad (37)$$

Where,  $t$  is the storage temperature in °C.

Three varieties of wheat were considered in this study (Durum, hard and soft wheat) to better confirm the use of the method in all types of wheat.

Table 5: Modified Henderson Constants for moisture contents in wheat species

Grain type	Constants		
	K	D	N
Durum wheat	$2.5738 \times 10^{-5}$	70.318	2.211
Hard wheat	$2.3007 \times 10^{-5}$	55.815	2.2857
Soft wheat	$1.2299 \times 10^{-5}$	64.346	2.5558

Source: ASAE, (2016)

Where, K and D are linear constants and N is an exponential constant of wheat grains.

### 4.3 Results and Discussion

The results of the proposed method presented in this section were carried out in MATLAB®. The simulation results represent the moisture and temperature variations with respect to dielectric properties of wheat grains in the storage facility. The applied electric field frequency used in this study is between 1-15 kHz ranges. This frequency range is selected in this study for simulation due to its good penetration depth through the grains medium since it has lower radio waves. It is also a non-ionizing radiation which can never cause any harm to human.

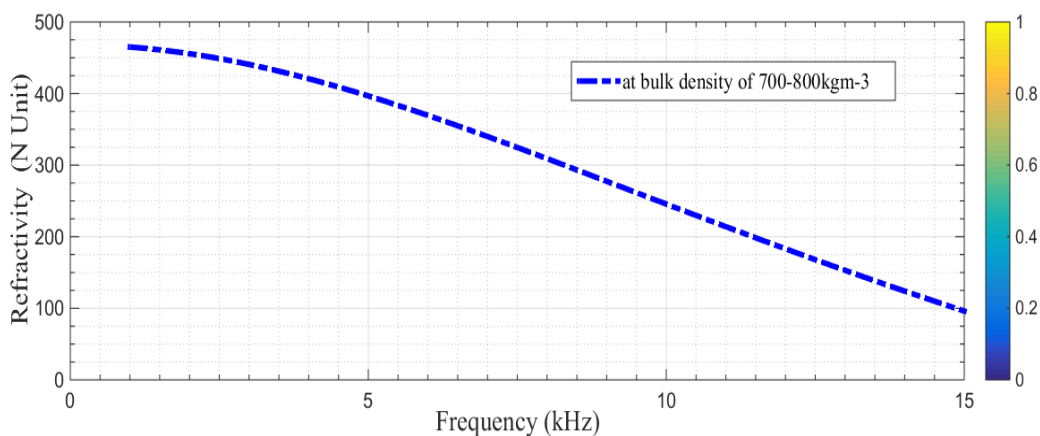

Figure 17: Frequency response with refractivity

Fig. 17 shows frequency dependence of reflectivity in the wheat grain bulk. Fig. 18 confirms that dielectric constant of wheat grains decrease with the increase in frequency as reported earlier by Datta (2001). It indicates that the dielectric relaxation might be attributable to bound water in wheat grains. Both figures almost demonstrate similar behavior, this might be due to the net polarization drop that the polarization mechanisms stop to contribute in (a material) bulk of wheat grains when subjected to the increasing frequency of the applied electric field.

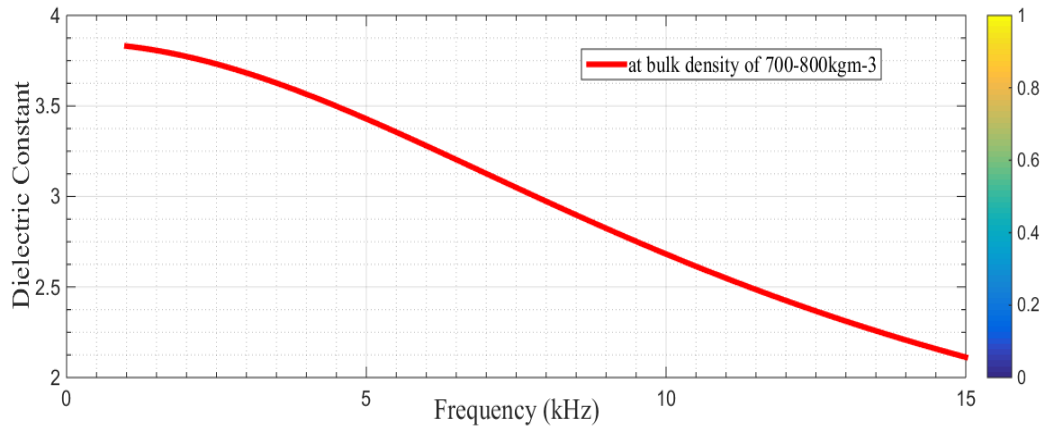

Figure 18: Frequency response with wheat dielectric constant

From Fig. 19, it is found that there is a variation of dielectric constant of wheat bulk with the increase in temperature. The dielectric constant exhibits the decrease behavior with an increase in temperature. This might be due to the permanent dipoles (orientational polarization) exhibited in wheat grains as reported earlier by Albornoz (2013) that orientational polarization is always strongly temperature dependent.

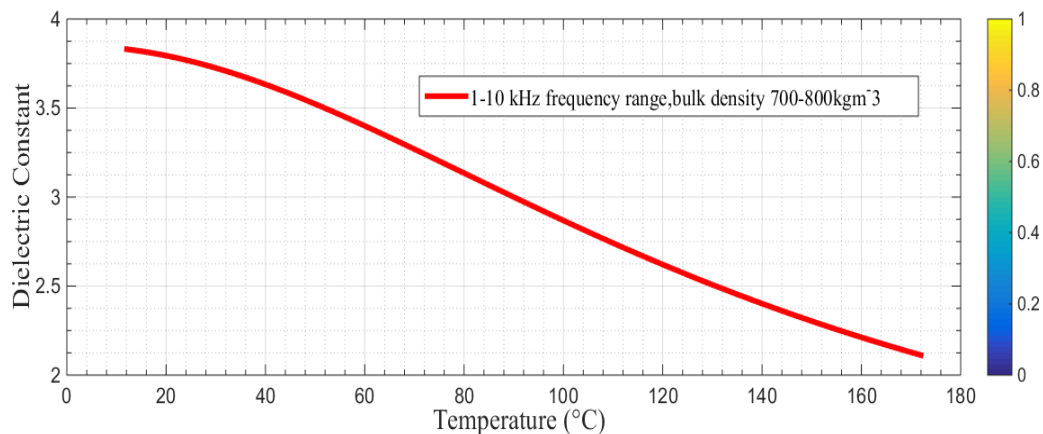

Figure 19: Temperature as the function of dielectric constant of wheat

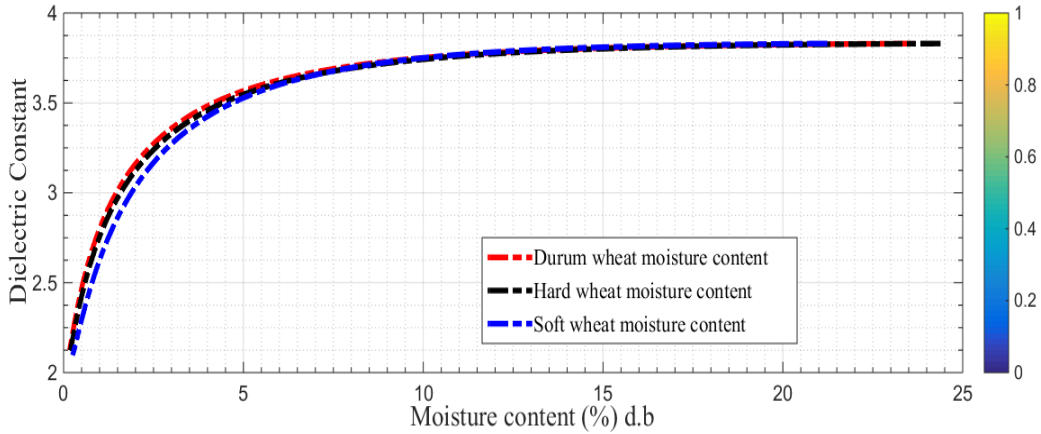

Figure 20: Moisture content as the function of dielectric constant of wheat

The dielectric constant and refractivity as the function of moisture content are presented in Fig. 20 and 21. Both demonstrate the exponential increase as the moisture content increases as might be due to rapid absorption (addition) of water. The plots indicate that high moisture content level dominates the changes. This might be due to the changes in polarization caused by addition of water content in wheat grain bulk the findings which are contrary to the ones in Fig. 17 and 18.

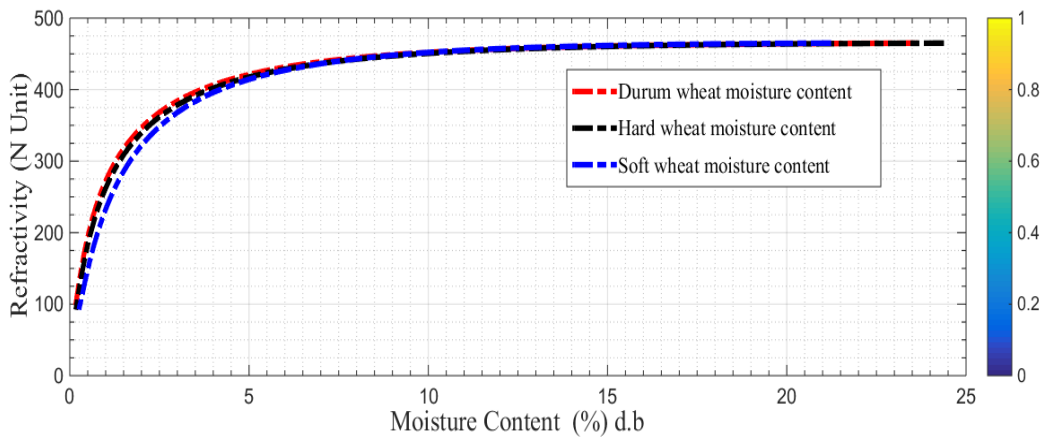

Figure 21: Moisture content as the function of refractivity

Fig. 22 illustrates the way wheat varieties behave differently over the relative humidity as they approach the point of saturation. This might be due to the different physical properties of each variety. It also demonstrates a coexisting increase in relative humidity with moisture content. It exhibits the sigmoid curve which replicates type II isotherm characteristics of food

stuffs according to BET classification (Andrade, 2011). It is also observed that temperature decreases with an increase in moisture content as shown in Fig. 23. The results match with data given in modified Henderson model for wheat storage management as reported by Agnew. (2017).

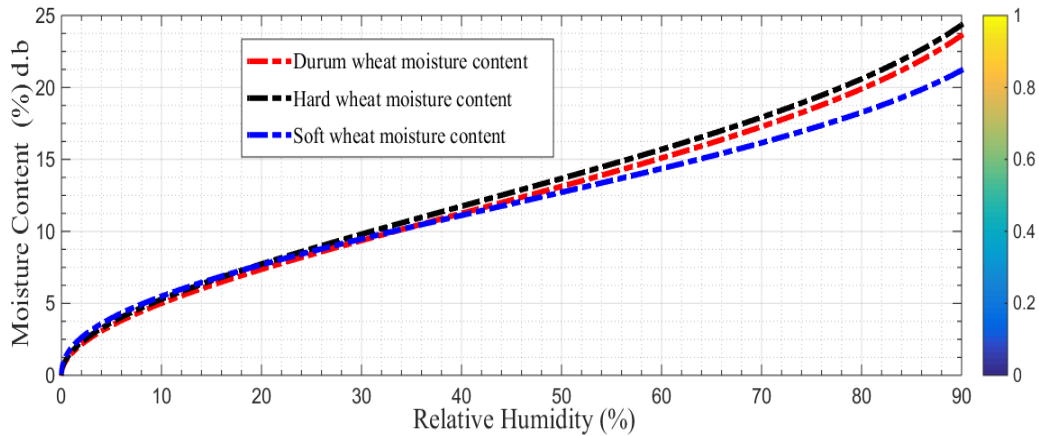

Figure 22: Relative humidity as the function of moisture content

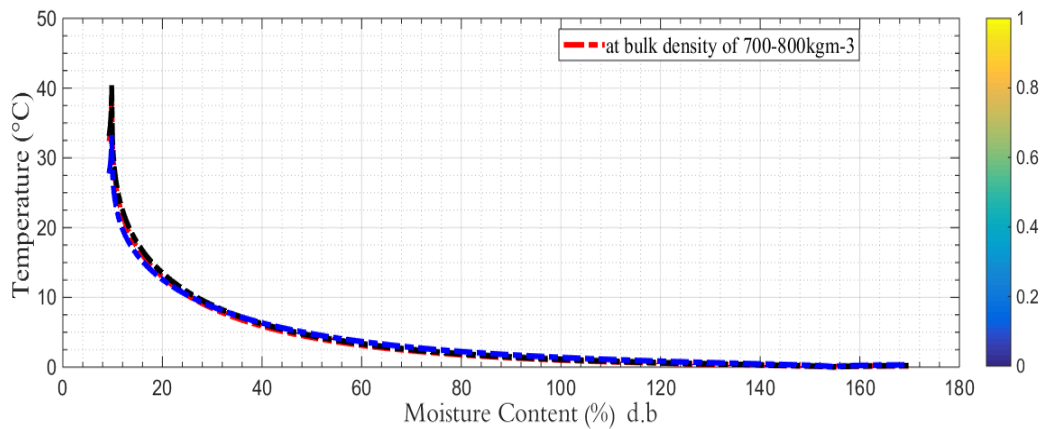

Figure 23: Moisture content as the function of temperature

#### 4.4 Conclusion

In this work, moisture contents and temperature of the wheat grains in the storage facility were determined using MATLAB® program. Their relationships with the wheat electrical properties (dielectric properties) under the influence of frequency in the range of 1-15 kHz and the bulk density of 700-800 kgm<sup>-3</sup> were presented. Dielectric properties, refractivity, temperature and moisture contents in three varieties of wheat were compared. The method

proposed here serves considerably to the implementation of the technology of sensing the moisture contents and temperature of the wheat grain storage by radio frequency as the effective method. This indicated that the electrical properties of all types of wheat are very sensitive to the applied electric field frequency. As the consequence of the temperature and moisture content variation, the dielectric properties of wheat grains are always changed. The proposed method based on the refractivity was successfully formulated to solve the problem of electric field frequency interaction with dielectric wheat grains that responds to the variation of temperature and moisture content through the wheat grain bulk (large amount of wheat) in the storage facility.

## CHAPTER FIVE

### **A Design for Forecasting Wheat Grains Storage Condition using Hidden Markov Model**

#### **Abstract**

Wheat has been very important cereal food around the world to date. Its storage is mostly affected by temperature and moisture variations that degrade its quality. This has led to the importance of close monitoring of its storage for food security purposes. This study presents a three state grain storage condition technique based on Hidden Markov Model for forecasting the grain storage condition. The work is motivated by the fact that the variation of weather condition in storage facility produces alternating dry, wet, and spoilt regimes. The method assumes that the condition of the grains is governed by a few states, with daily transition between them. MATLAB tool ® was utilized to perform numerical simulation for the proposed designed method. Numerical simulation results indicate that the designed method is proficient of forecasting the grain storage condition. It is therefore recommended that the implementation of the technology would be important for its applications in real environment.

#### **5.0 Introduction**

The estimation for global wheat production in 2011 was about 676 million tons (Alkadri *et al.*, 2014). The importance of wheat has been mainly featured to its ability to be ground into flour, which forms the essential constituents for numerous food types. Wheat crops are exposed to many fungi which are toxic such as Fusarium, Aspergillus, and Penicillium. Mycotoxins are usually produced by these fungi, which are dangerous for both human and animal health. Wheat can be affected during pre or post-harvest with mycotoxins. Mycotoxin life depends on a number of factors such as fungal strains presence, climatic and geographical conditions, and crop management practices (Alkadri *et al.*, 2014; Savi *et al.*, 2014; Tefera *et al.*, 2011). Several cereal grains such as maize, wheat, millet, sorghum and rye are stored in various facilities so as to save them for seed, food between harvesting seasons, and supply feed for livestock. They are stored for an irregular period before being supplied to users as food, feed, seed, or other uses (Kaleta and Górnicki, 2013b). Long time storage of cereal grains without deterioration normally needs the dry matter content of at least 85% in the grains (Hackl *et al.*, 2010) and once this is altered, then the grains get affected. It should be noted that grain storage environment is one of the key factors which determines the degree of

grain viability. The main factors of this are the moisture content of the seed and the storage temperature. The temperature and moisture of the storage facility can be controlled to reduce grains' spoil and the rate of insect activity, feeding, developing and reproduction depends on these factors. High moisture content (greater than 13%) in grain causes damage because it promotes diseases (Kaleta and Górnicki, 2013b). High moisture levels in the storage, fungi, bacteria and the respiration of grains usually produce water vapour and heat which motivate further microbial activities (Bartosik *et al.*, 2008). High storage temperature causes a rapid turn down in seed viability and loss in grain quality. This results in spoiled grain which is unfit for use (Kearney, 2006).

Hence based on the fact that the variation of weather condition in storage facilities can result into alternating (dry, wet, and spoil) regimes, then this work used these three state grain storage condition based on Hidden Markov model to forecast the grain storage condition. The study assumed that the condition of the grain is subjected to a few states with daily transition between them.

### **5.1 Research Works on the Forecasting by Hidden Markov Model**

Cereal grains' conditions monitoring during storage facility is very important. They need to be known to the user (farmer or stakeholder) so that the quality of grains can be well observed. Monitoring of such condition can be solved by Hidden Markov technique, the model or technique which is among the models for modeling a broad span of a time sequence of data. It is well known to characterize the hidden states with observation sequences more than any other predictive model (Blunson, 2004; Kriti Shrivastava, 2015). Artificial intelligence researchers have been performing studies on its applications as described below:

The study by Li and Cheng (2006) presented a temperature forecasting model based on HMM. The model considered only two states of fuzzy time series, where the sequence of observations depended on the previous states at any time. The authors found that the model outperformed all previously proposed models in terms of mean squared error. A work conducted by Bracken *et al.* (2014) presented a technology using a HMM with large-scale climate indices that drove multidecadal variability. It detected the regime shifting features that misrepresented the risk of delayed wet and dry periods in Colorado. However, the method did not consider the seasonal ensemble forecasting for water resources management. Another study by Pineda and Willems (2016) reported the analysis of four states that played



distinct roles between December and May rainy season. The network of 68 stations in 21 catchments of the Pacific–Andean River Basins in Ecuador and Peru (PAEP) were considered. Hidden Markov model was used in estimating the daily states of the area. The wet properties of the PAEP were described successfully by the model; however, it fails to predict the complex spatial dependences of rainfall occurrences over elevation stations. Moreover, daily winter rainfall prediction in relation to the dry land management was investigated in the Coquimbo Region of central-northern Chile. The study focused on the rainfall intensity, total season rainfall, and rainfall frequency. A non-homogeneous hidden Markov Model-driven was used to model stochastic daily rainfall sequences. The results indicated that the model successfully forecasted the rainfall, which implied that it was potential for seasonal predictability (Verbist *et al.*, 2010). The study by Mallya *et al.* (2012) presented the hidden Markov model based on the drought index. The study assessed drought responses using monthly precipitation and stream flow data. The authors found that the method overcomes the limitations of standard precipitation index (SPI). However, the study did not consider the test on the stability issues and estimation of parameters of the HMM model for the real environment applications.

Generally, most of the previous studies have just reported the outdoor daily and season weather condition forecasts. Also, there are some of the studies reported only the detection of moisture contents and temperature of the grain samples (Garcia *et al.*, 2009; Gastón *et al.*, 2009; Prandini *et al.*, 2009). However, there is no any research according in the literature review, which has been conducted on the grain storage condition forecasting for the purpose of monitoring the day to day grain storage condition. This study focuses on the forecasting of daily occurrence of weather condition in the grain storage to help the farmers and stakeholders for the future crop planning and management.

The study based on design used HMM by deriving probability distributions from temperature and moisture content records in the grain storage. This technology is the stochastic model in which daily probability of grains condition occurrence might be conditioned on few numbers of grains hidden states, with Markovian transitions between them. It considers the wheat grain storage weather condition in relation to the individual grain state influenced by the ambient weather changes.

## Hidden Markov Model

Hidden Markov model is widely used for artificial intelligent activities such as speech recognition, fault diagnosis, biological information science, spectral sensing, computer language recognition, and multi-user detection (Chen and Qiu, 2010). This model defines the probability distribution over sequences of hidden states  $Q$  and observations  $O$ . It is a way of relating a sequence of observations to a sequence of hidden states that explicate the observations. This model is always explicated by only three vital problems given HMM with transition  $A$ , observation  $B$ , and initial probabilities  $\Pi$  (Wang *et al.*, 2012). These problems are described as:

### A. Evolution Problem:

The model determines the probability (likelihood  $P(O|\lambda)$ ) that a particular sequence of symbols  $O_t$  was generated by that model HMM  $\lambda = (A, B, \Pi)$  (Bartolucci and Lupporelli, 2016; Tobon-Mejia *et al.*, 2012) which can be done by using forward algorithm. The likelihood probabilities are described by:

$$P(O) = \sum_Q P(O|Q)P(Q) \quad (38)$$

### B. Decoding Problem:

Given a HMM  $\lambda = (A, B, \Pi)$  and a sequence of observations  $O = o_1, o_2, \dots, o_T$  find the most probable that correspond with the sequence of hidden states  $Q = q_1, q_2, \dots, q_t$  (Tobon-Mejia, *et al.*, 2012). It is solved using Viterbi algorithm. The highest probability is described by (Choi and Cardie, 2007; Dong and He, 2007; Scott, 2011) as:

$$\delta_t(i) = \max_{q_1 q_2 \dots q_t} P[q_1 q_2 \dots q_t = i, o_1 o_2 \dots o_t | \lambda] \quad (39)$$

It is given along a single path at time  $t$ , which accounts for the first  $t$  observations and ends in state  $i$ .

### C. Learning Problem:

HMM parameters are trained to give out the optimal model. One of the algorithm for Expectation-Maximization (EM) Baum-Welch algorithm that trains transition  $A$ , observation  $B$ , and initial  $\Pi$  probabilities of HMM. This happens when the observation sequence  $O$  and

the set of states in the model are given, (AlKhateeb *et al.*, 2011; Titsias *et al.*, 2016; Visser and Speekenbrink, 2010).

With the initial model:

$$\lambda = (A, B, \Pi) \quad (40)$$

The re-estimation is considered to give the new model as:

$$\bar{\lambda} = (\bar{A}, \bar{B}, \bar{\Pi}) \quad (41)$$

According to Heigold *et al.* (2008), the initial model defines the critical point of the likelihood function that the new model is more likely than the initial one in the sense that:

$$P(O|\bar{\lambda}) \geq P(O|\lambda) \quad (42)$$

The new model is the key instrument from which the observation sequence is more likely to have been produced. The output of re-estimation is what is called a maximum likelihood estimate of HMM. This re-estimation is readily implemented using EM algorithm in which E step is done through the Baum auxiliary function (Choi and Cardie, 2007; Heigold *et al.*, 2008; Hsiao *et al.*, 2009; Kanevsky *et al.*, 2011; Nguyeny *et al.*, 2011; Zhong and Ghosh, 2001):

$$P(\lambda, \bar{\lambda}) = \sum_Q P(Q|O, \lambda) \log[P(O, Q|\bar{\lambda})] \quad (43)$$

Where the m step is the maximization over the new model (Choi and Cardie, 2007; Hsiao *et al.*, 2009; Nguyeny *et al.*, 2011; Ozerov *et al.*, 2009; Zhong and Ghosh, 2001) as:

$$\max_{\bar{\lambda}} [Q(\lambda|\bar{\lambda})] \Rightarrow P(O|\bar{\lambda}) \geq P(O|\lambda) \quad (44)$$

The maximization is done until the likelihood converges to the critical point.

## 5.2 Methodology

### Wheat Grain Storage Condition Forecasting Model Design

The method assumes that wheat grain storage undergoes different condition in the influence of indoor and ambient weather conditions. It also assumed that a cold condition (normal) is within the temperature of 13.9 – 20.9 °C, warm condition between 21 – 42.9 °C and hot condition is more than 42.9 °C. This gives sequence states of cold, warm and hot conditions respectively. From previous studies, it was identified that the temperature variation with moisture contents affects the grains from mycotoxin and insect activities (Paterson and Lima, 2010; Wagacha and Muthom, 2008; Wu *et al.*, 2011). The safe moisture content (Kaleta and Górnicki, 2013a) of the wheat grains is about 13% whereby the seed seemed to have its normal state (dryness). The moisture content in the range of 14 -16.5%, a grain became wet (wetness) whereby it gets affected by the mold and insect activities. But, it gets more affected once the moisture content is more than 16.5% which motivates mold and insect growth (mycotoxin disease that spoil the grain quality). Moreover, under the assumption that the next occurrence of a cold or a warm or a hot condition is influenced only by the weather condition of the current condition, the process of state occurrence can be described by a 3 state Markov chain with cold, warm and hot conditions. For that reason, first order HMM is used as the heart of proposed method for forecasting the conditions of the wheat grain bulk in a storage facility as illustrated in Fig. 24.

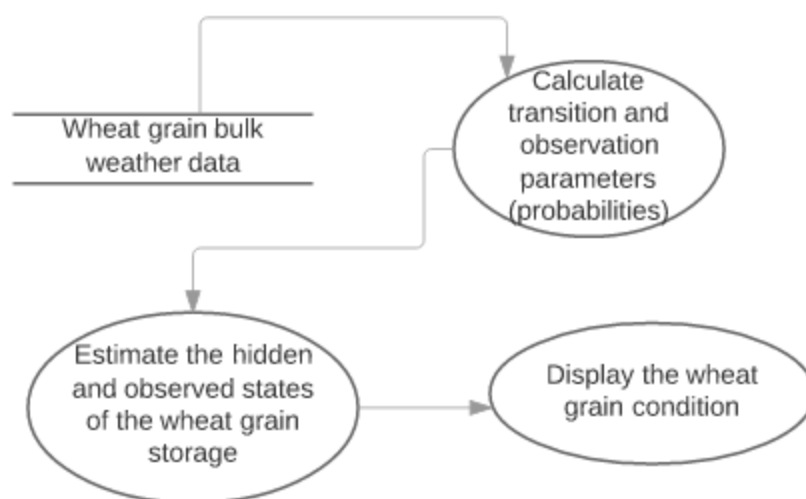

Figure 24: Wheat grain storage condition forecasting method layout

The two sets of states of the model are derived from the internal and external conditions of wheat grain bulk. The set of internal states  $Q$  are taken from the internal characteristic of individual wheat grain. But the external states are drawn from the physical visibility of individual wheat grain. Moreover, the probabilities are derived from training data collected from Azam Grain Milling Co Ltd located in Dar Es Salam, Tanzania. The model describes three internal states which are defined in  $Q$  for each condition. These are coldness ‘ $c$ ’, warmth ‘ $w$ ’ and hotness ‘ $h$ ’ states. They are considered as events that are mostly happening in a grain bulk during storage and are also not directly visible. Each of these states is represented as a hidden state that follows Markov property whereby the next state of grains depends on the current state as shown in Fig. 25. The work also assumes the other set of external states  $O$  that are visible. These depend on the internal conditions (hidden) of grains as demonstrated in Fig. 26. They are now described as dryness ‘ $D$ ’, wetness ‘ $W$ ’, and Spoil ‘ $S$ ’.

The contribution of this work focuses on the dynamic conditions of grain bulk interaction with the storage environment. It models the interaction while the storage condition is both changing and not changing. This is in contrast with the traditional approaches that solely deal only with temperature and moisture content detection from the grain samples. In this model, the observed states predetermine the visible changes over time and the hidden states signify the causal targets that produce the observed behaviour. So by HMM, the most optimal observation sequence of wheat grain condition for a given model is captured through EM estimation as demonstrated in Fig. 27. Matlab software package ® is used in this work to simulate the proposed method.

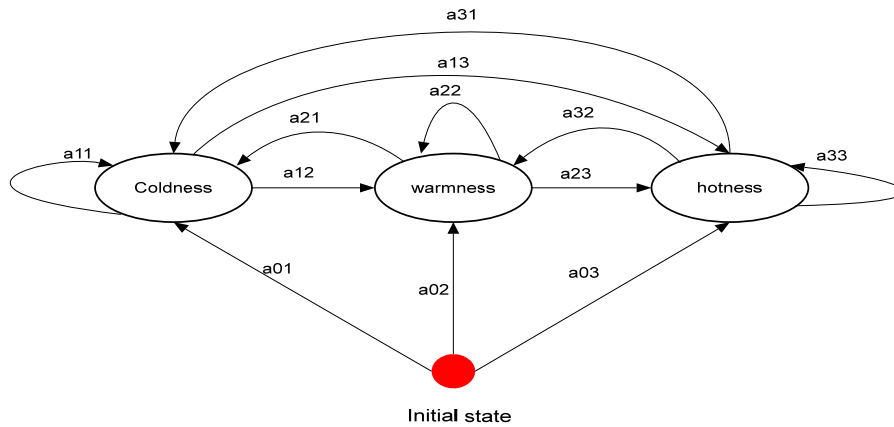

Figure 25: Markovian hidden states

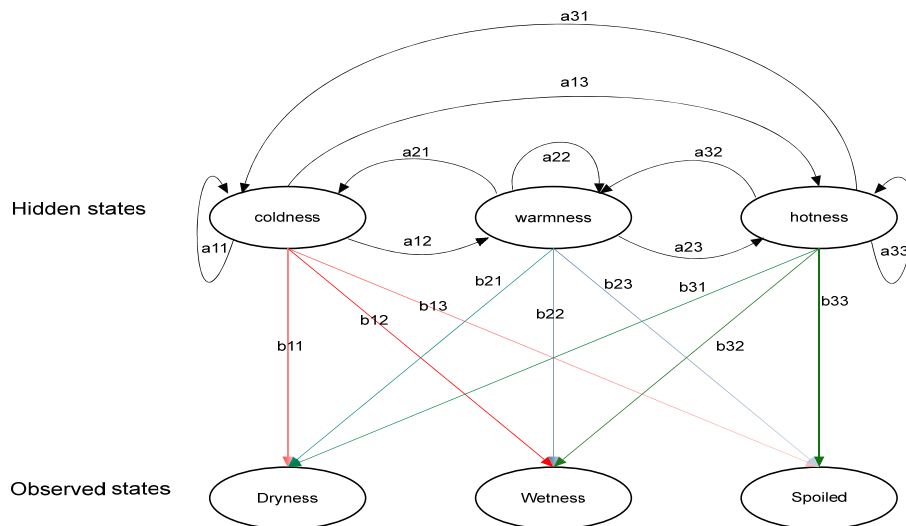

Figure 26: Original Hidden Markov model

The number of hidden states, observations and transitions between hidden states along with a training set of sequences of observed symbols are given.

The model has ( $N=3$ ) finite states:

$$\{s_i\} = q \quad (45)$$

The model assumes that the internal grain states can only obtain three possible outcomes under weather variations: coldness ( $S_i=1$ ), warmness ( $S_i=2$ ), or hotness ( $S_i=3$ ). At each time  $t$  the scheme can be in any of these states and can transit to another with probability of:

$$a_{ij} = P(q(t + 1)|q(t)) \quad (46)$$

These probabilities are made to vary with time  $t$  (days). It presents  $a_{ij}$  the probability that  $q$  portrays wheat status  $i$  in period  $t$ , conditional on portraying the wheat status  $j$  in period  $t+1$ . The model has as set of visible states ( $M=3$ ):

$$\{v_i\} = o \quad (47)$$

It is assumed the model has Markov stationary that the output observation at time  $t$  is dependent only on the current state; it is independent of previous observations and states. So in each state  $q$ , there is a probability of observing a certain visible state  $o$ :

$$b_{jk} = P(o(t)|q(t)) \quad (48)$$

This work is defined by the number of states, the initial states state transition and the response distribution as:

Initial transition matrix  $\Pi$ :

$$\Pi = [a_{01} \quad a_{02} \quad a_{03}]$$

Transition matrix  $A$ :

$$A = a_{ij} = a_{13} = \begin{bmatrix} a_{11} & a_{12} & a_{13} \\ a_{21} & a_{22} & a_{23} \\ a_{31} & a_{32} & a_{33} \end{bmatrix}$$

Observable matrix  $B$ :

$$B = b_{jk} = b_{13} = \begin{bmatrix} b_{11} & b_{12} & b_{13} \\ b_{21} & b_{22} & b_{23} \\ b_{31} & b_{32} & b_{33} \end{bmatrix}$$

Estimated Transition matrix  $\bar{A}$ :

$$\bar{A} = \bar{a}_{ij} = \begin{bmatrix} \bar{a}_{11} & \bar{a}_{12} & \bar{a}_{13} \\ \bar{a}_{21} & \bar{a}_{22} & \bar{a}_{23} \\ \bar{a}_{31} & \bar{a}_{32} & \bar{a}_{33} \end{bmatrix}$$

Estimated Observable matrix  $\bar{B}$ :

$$\bar{B} = \bar{b}_{jk} = \begin{bmatrix} \bar{b}_{11} & \bar{b}_{12} & \bar{b}_{13} \\ \bar{b}_{21} & \bar{b}_{22} & \bar{b}_{23} \\ \bar{b}_{31} & \bar{b}_{32} & \bar{b}_{33} \end{bmatrix}$$

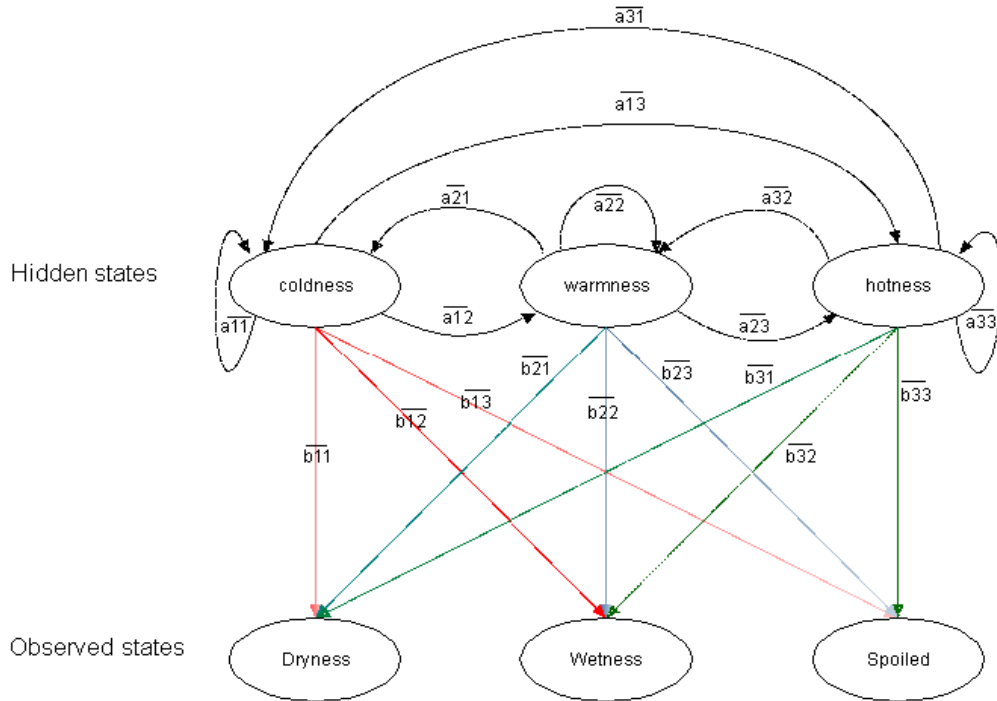

Figure 27: Estimated Hidden Markov model topology

Transition probability matrix of the model calculated from the training data in appendix II is:

$$A = \begin{bmatrix} 0.75 & 0.2 & 0.05 \\ 0.2 & 0.7 & 0.1 \\ 1 & 0 & 0 \end{bmatrix}$$

The transition probability for each pair of contiguous hidden states is calculated such that the next is dependent only on the current. This focuses on the maximum likelihood path that has the highest observation probabilities. Observation probability matrix of the model calculated from the training data in appendix II is given as:

$$B = \begin{bmatrix} 0.63 & 0.32 & 0.05 \\ 0.5 & 0.4 & 0.1 \\ 1 & 0 & 0 \end{bmatrix}$$



### 5.3 Results and discussions

The storage condition of wheat grain bulk is supposed for random storage and weather conditions. The results were simulated and depicted in Fig. 28 to 40. The work has considered only a set of three hidden states to calculate the Markov type transition probabilities with three observed states of wheat grain. It describes the probability changes with respect to time (10 to 180 days) for the bulk of wheat grains.

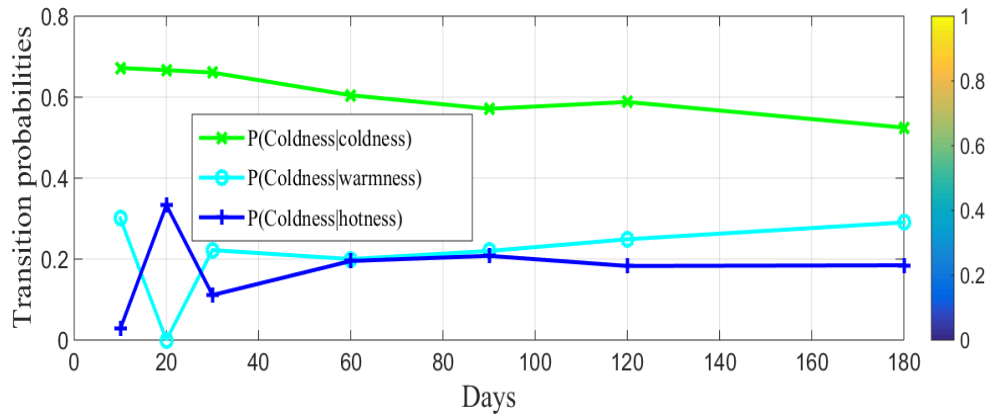

Figure 28: Transition probabilities from other states to cold state estimated from 10 to 180 days

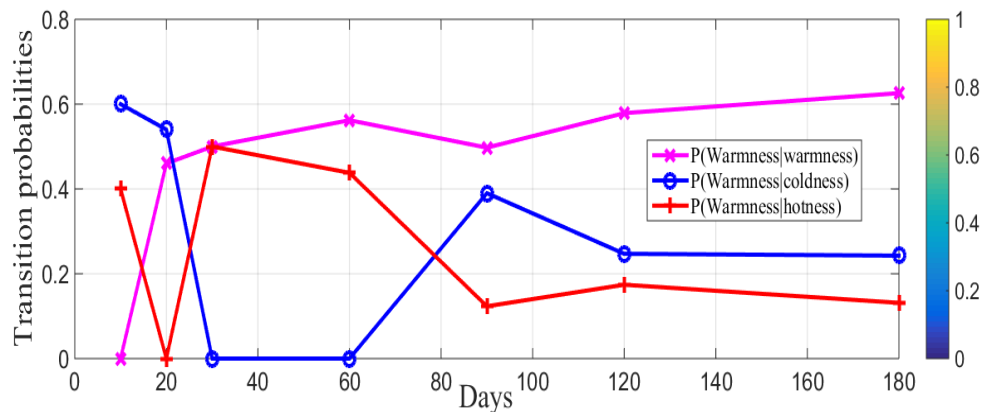

Figure 29: Transition probabilities from other states to warm state estimated from 10 to 180 days

Fig. 28 to 30 present the transition probabilities of wheat storage hidden states and Fig. 31 to 33 present observation probabilities varying with time. These probabilities are the estimates for the purpose of giving optimal forecasts of wheat grain bulk storage condition. Fig. 28 indicates the states to cold transition probabilities for wheat grain storage condition with

time. The maximum likelihood is observed at cold to cold states (in green) though decreasing with time. This implies that the grains might be in a safe weather. Fig. 29 shows the the states to warm transition probabilities where the optimal result is first observed at warm ( in blue) from cold state in the first 10 days, and then warm to warm (in mangeta). This entails that storage hidden states might affect the storage condition with time. Fig. 30 also demonstrates the states to hot transition probabilitis by provinding the the maximum result at hot to hot state (in yellow). These findings from Fig. 28 to 30 imply that the state with optimal result could contribute to the storage condition. This is more emphasized in Fig. 31 to 33 that from 10 to 120 days, the cold state produces the maximum results; 120 to 160 days period is dominated by the warm states and periond between 160 to 180 days by the hot state. This generally advocates that at the end, the wheat grain quality would less likely deteriorate in storage with time due to the occurance of hot state than the occurrence of other hidden states.

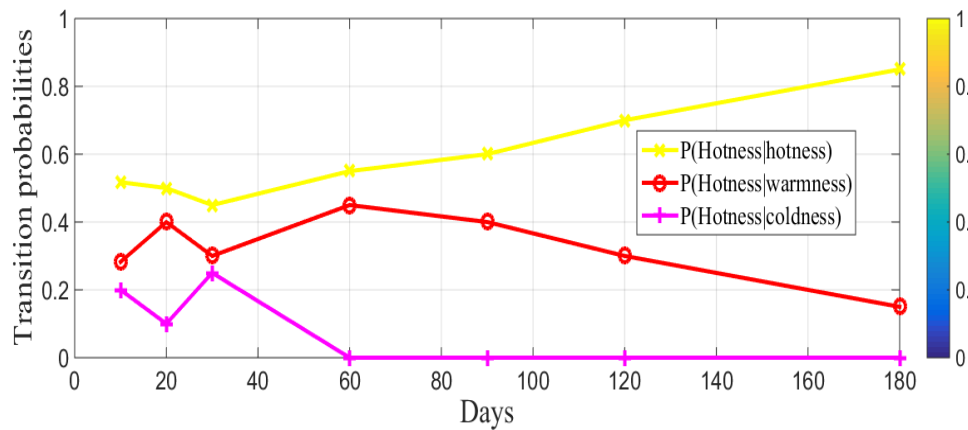

Figure 30: Transition probabilities from other states to hot state estimated within 10 to 180 days

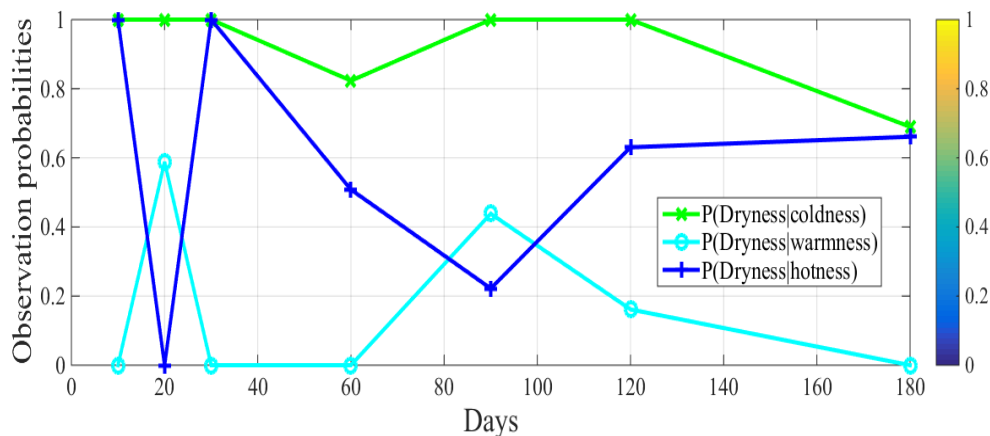

Figure 31: Observation probabilities of Dry state given hidden states estimated from 10 to 180 day

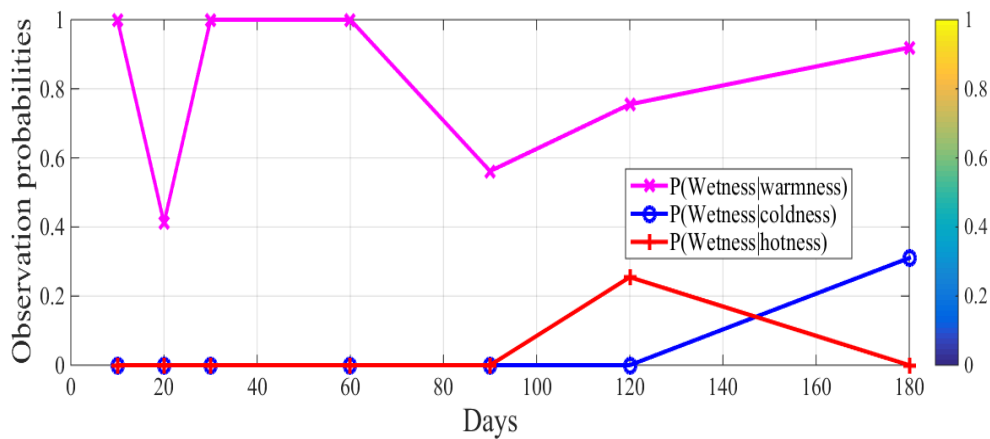

Figure 32: Observation probabilities of wet state given hidden states estimated from 10 to 180 days

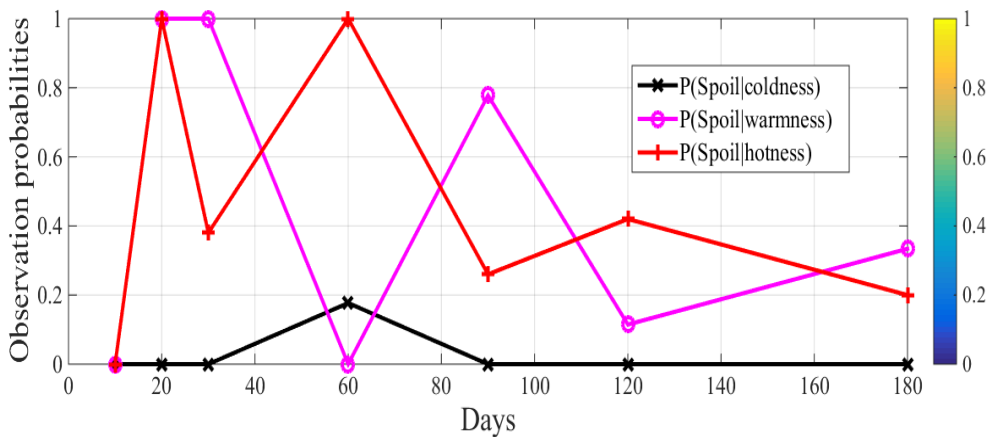

Figure 33: Observation probabilities of spoil state given hidden states estimated from 10 to 180

Furthermore, from Fig. 34 to 40 the states of wheat grains with increasing time are presented. The observed states correspond to the hidden states. The length of blue line represents the collective likelihood of the model up to the spot in time. The red line indicates the observations of the optimal model. It was found that, certain states stayed in the same states for long period of time give less frequencies of observations as illustrated in Fig. 34 and 35, whereas high variations of hidden states provided more variations of observations as shown from Fig. 36 to 40. The sign of high frequent transitions to hidden states confirm the essence that once the weather conditions highly vary, the storage would be in poor observed states as illustrated in Fig. 40. these findings imply that; this environment would be not conducive for the grain storage since it may cause the loss of grain quality. Due to this situation, the grains

(food) could be vulnerable to toxic mycotoxins and insects as earlier reported by Paterson and Lima (2010), Wagacha and Muthomi (2008) and Wu *et al.* (2011).

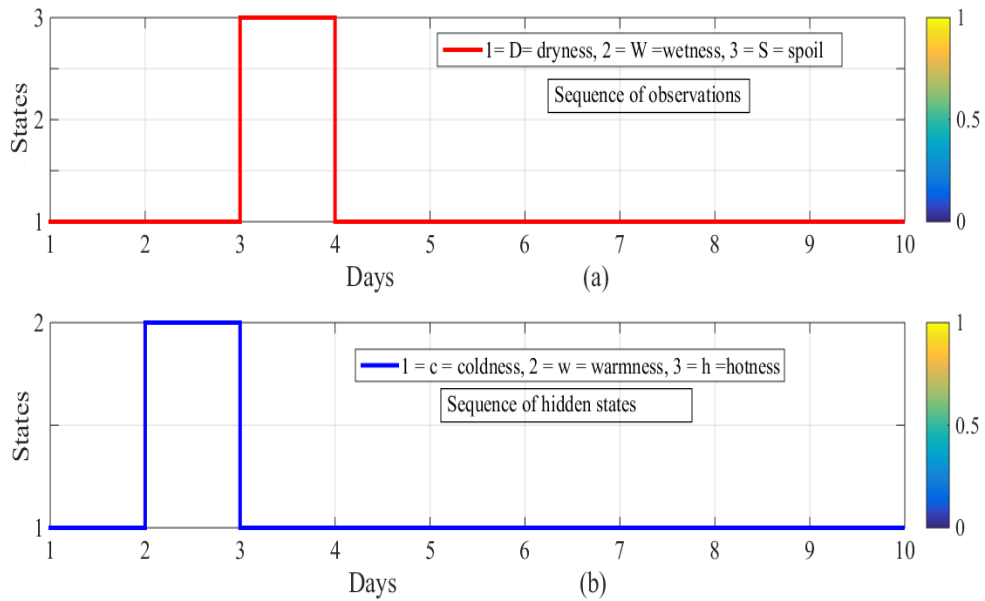

Figure 34: Varying time in 10 days via (a) observations and (b) hidden states

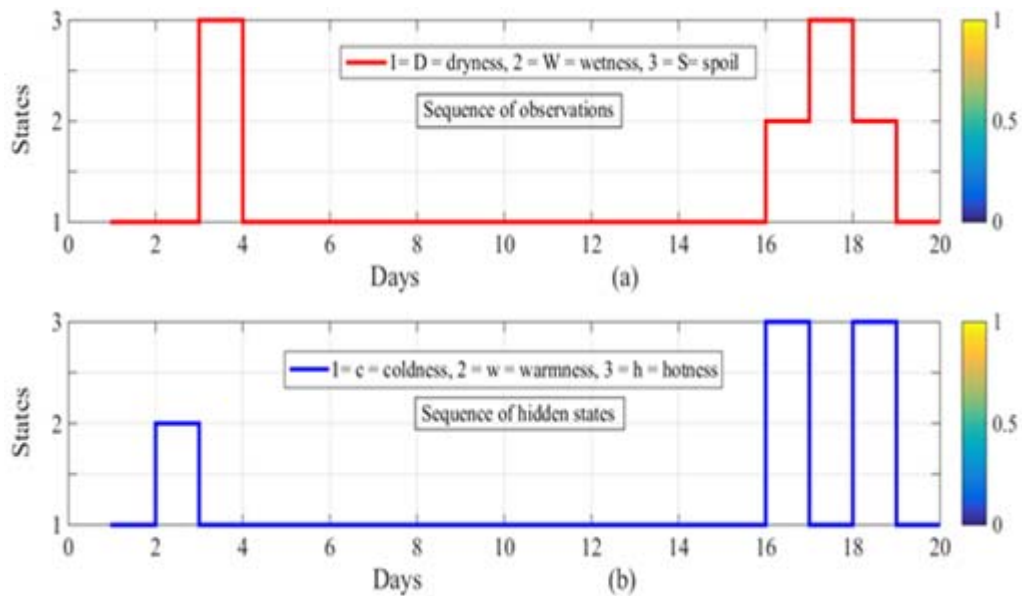

Figure 35: Varying time in 20 days via (a) observations and (b) hidden states

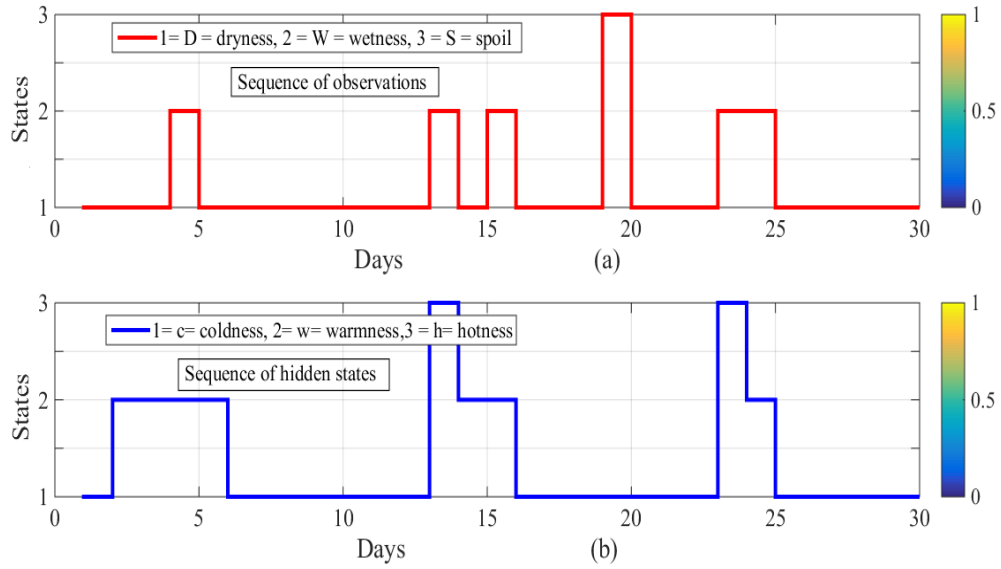

Figure 36: Varying time in 30 days via (a) observations and (b) hidden states

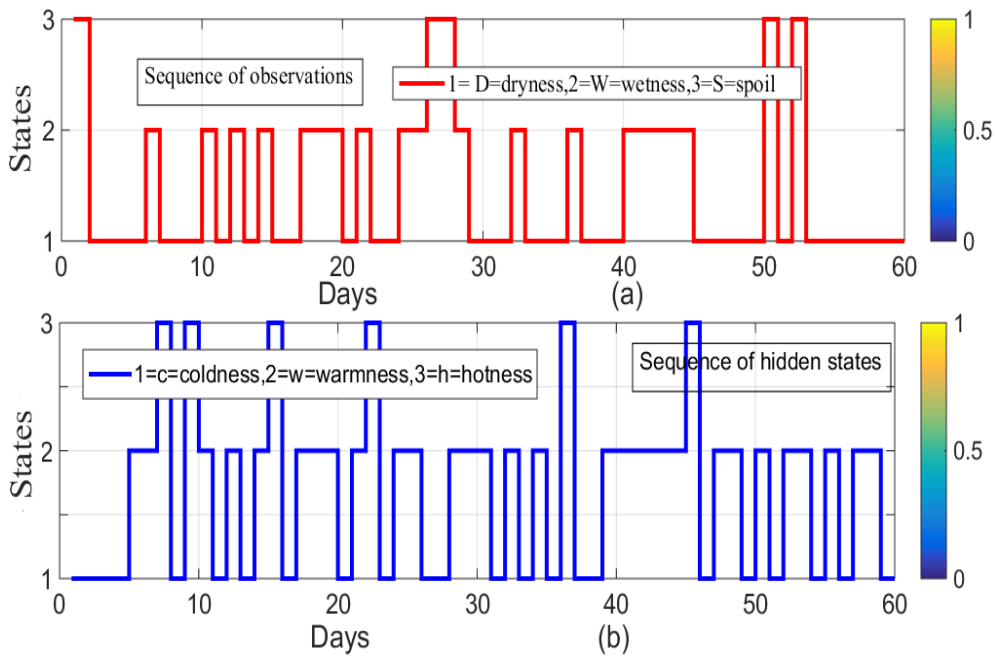

Figure 37: Varying time in 60 days via (a) observations and (b) hidden states

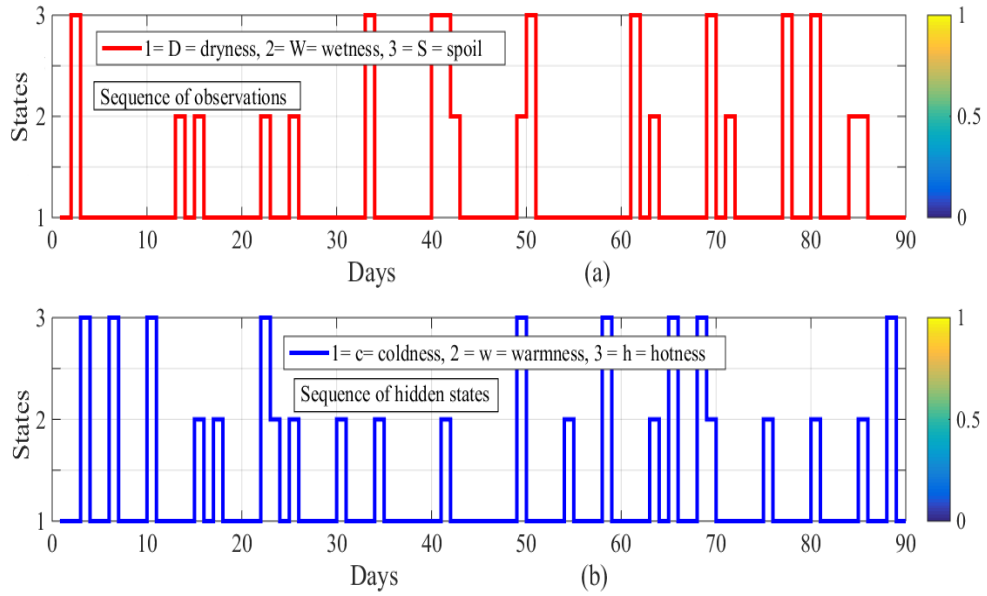

Figure 38: Varying time in 90 days via (a) observations and (b) hidden states

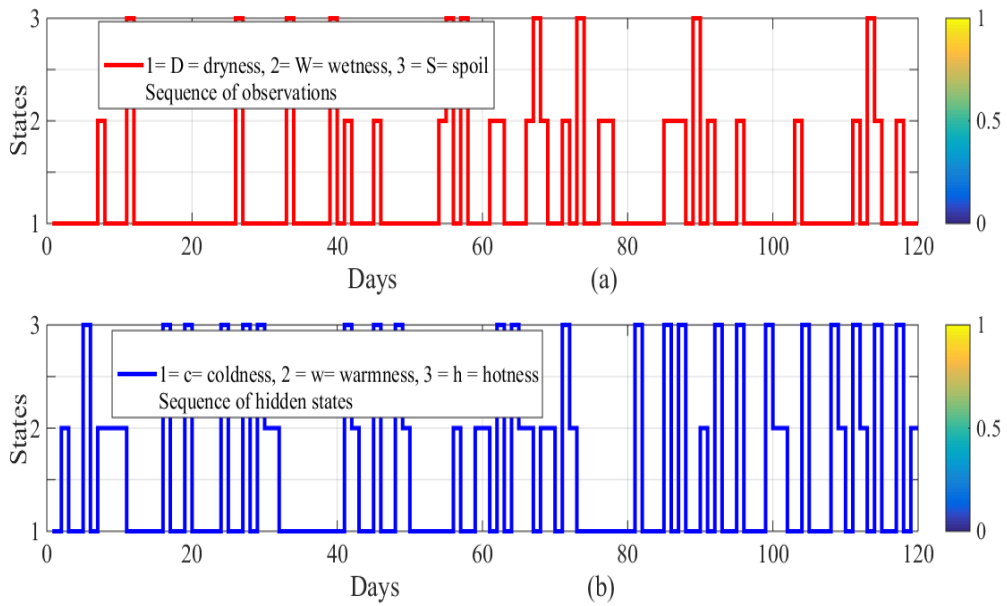

Figure 39: Varying time in 120 days via (a) observations and (b) hidden states

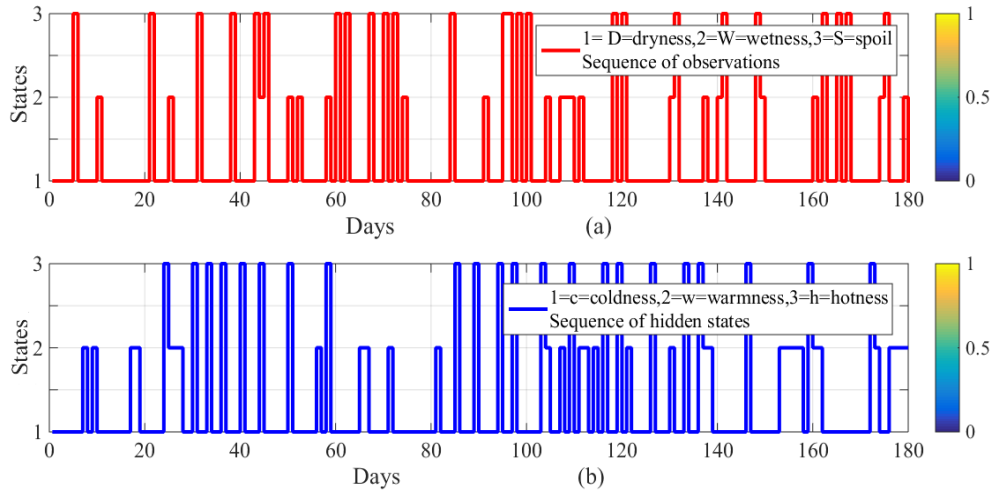

Figure 40: Varying time in 180 days via (a) observations and (b) hidden states

## 5.4 Conclusion

Monitoring and forecasting methods are essential tools for appropriate measures against negative impacts from weather condition variation in the wheat grain storage. When condition forecasting is done, could be supportive to decision making process for grain management. This study proposed a three state grain condition model for predicting wheat grain storage condition forecasting. Three underlying hidden states based on Hidden Markov Model that emanate visible observations were identified from collected data obtained from Azam Grain Milling Co Ltd, located in Dar Es Salaam, Tanzania. The designed method was simulated in MATLAB® and the results confirmed the possibility of an increase in the events of warm and hot states with time, and a decrease in the events of cold states.

The findings imply that the transition probability for hot to hot condition could increase more in future. Therefore, it is concluded that the occurrence of intensive hot state in the storage will severely spoil the grains due to weather variations. The increasing trend of hotness may kill important organisms of wheat grains. The increasing trend of warmness may also motivate the biological activities that can affect the grains. The study has shown that it is possible to achieve good results using hidden Markov model. Therefore, Hidden Markov Model can be used to project the day to day occurrence of wheat grain bulk storage condition. Moreover, the forecasted data will be useful inputs for the farmers and stakeholders for proper crop management and grain storage planning. However, the proposed method has to be tested so that it can be applied in real environment in the future.

## CHAPTER SIX

### Performance Evaluation of the Model for Monitoring the Grain Condition in the Storage Facility Based on ZigBee Technology

#### Abstract

In food security, temperature and moisture content variation is intensively a premeditated factor. For safety measures, it is often measured at food storage level. This study reports the performance results of the innovative model for monitoring the grain crops condition based on ZigBee technology. In order to validate the performance of the proposed technology; a pilot study was undertaken on two different types of wheat grains: hard and soft wheat grains. Performance evaluation was carried out in Arusha Region, Tanzania, by utilizing the non-invasive sensors with measuring frequency of 10 kHz installed on the storage tank with a capacity of 250 dm<sup>3</sup>. Moreover, it was conducted into two different environments: a greenhouse and the open air area. The model technology offers two sub-models; one for determining the temperature and moisture content based on the relative humidity in relation to electrical properties of stored wheat grains, while the other one used for forecasting the storage condition based on Hidden Markov Model. During performance experiment, the measured data from the storage were sent remotely through ZigBee network to the monitoring station for monitoring purposes. The measurements were taken each day after 24 hours during the day time consecutively. In addition, the model data were compared with ones recorded by commercial probes. The results showed that the model is robust, precise and accurate. Therefore, the method has the potential capability to be applied in real environment for grain crop storage condition monitoring.

#### 6.0 Introduction

In the food production chain, monitoring of grain storage is an important process after harvest. During storage, there is a possibility for grain to be spoilt and become unusable due to the effect of weather variation. For that reason, smart monitoring is highly needed for the grain storage to report conditions leading to spoilage within it (Asefi *et al.*, 2015). In support of smart monitoring, ZigBee wireless technology has been adopted in several applications such as industrial, environment, health, agricultural and home automation. The technology has the excellent characteristics such as low cost, power consumption and maintenance that make it best wireless sensor network technology against other wireless technologies



(Agarwal, 2015; Alyoubi and El Emary, 2016; Liu *et al.*, 2008; Wang *et al.*, 2015). Some of the methods based on the ZigBee protocol have been proposed for detecting environmental parameters in the grain storage. They consider some postulations such as the automatic and resourceful selection schemes (Galande *et al.*, 2015; Mabrouk *et al.*, 2017; Onibonoje *et al.*, 2006; Surendra and Kishore, 2014).

Recently, the automatic methods based on ZigBee protocol have been designed and developed for monitoring the grain storage. The study by Galande *et al.* (2015) presented the development of an automatic monitoring of the grain storage based on ARM11. It used ZigBee network for transferring data timely and making right decisions. Sekhar and Swetha (2013) also reported the automatic monitoring of the grain storage based on ARM7 and ZigBee. ZigBee technology was used for incident detection of emergency. Moreover, an intelligent measuring and controlling system for the grain storage was developed. In this study, ZigBee network was used for remote data transmission to the monitoring computer in real time. It automatically measured the distribution of temperature, moisture content and relative humidity so as to give the references for the ventilation with the support of LabVIEW (Huiling *et al.*, 2011). Likewise, a smart sensor system based on ZigBee protocol using Arduino technology was proposed for monitoring grains in storage depots. It was designed for measuring humidity, light and temperature (Kumar *et al.*, 2012). The integrated wireless sensor system with a resourceful selection protocol for monitoring temperature, humidity and light variations in the grain storage was also designed (Onibonoje *et al.*, 2006). Moreover, the grain temperature monitoring system using ZigBee technology was developed by (Zhang *et al.*, 2009). It used the selection method to get the right parameters for the grain temperature monitoring to optimize the system.

Most of the granary monitoring systems (Dong *et al.*, 2014; Oluwafemi *et al.*, 2016) in the developing countries; however, are based on manual methods or wired networks. This leads to grain losses which in turn affect the quality and economic value of the grains. Their developments are also subjected to high maintenance and installation costs.

## **6.1 Literature review**

A monitoring system requires a proper model for the grain storage to accurately report the environmental parameters. This influences the system performance when operating in real

time. Some of the systems have been developed and tested. However, very little has been reported on the performance of the models for monitoring the weather condition of the grain storage in real time. Much emphasis has been directed onto system performance evaluation. The study by Zhou *et al.* (2008) reported the development of a wireless sensor network based on ZigBee protocol for the measurement system in grain storage as an alternative to the cable system. A sensor node was built to measure the grain temperature, moisture and pressure drop of the air through a bulk grain system. The aim of performance test was to check the wireless data transmission and the power consumption to optimize routing mechanism. A real time monitoring and controlling system for grain storage was also developed (Zhou *et al.*, 2009). It was developed based on ZigBee technology including a host computer, data management and control system anchored in Lab Windows/CVI. The study indicated the performance of the transmission distance of ZigBee wireless node in grain and the node lifetime estimation. Moreover, Kan-song *et al.* (2014) presented an application requirement of grain storage environment for a monitoring system design based on ZigBee wireless network. It used a strategy with the hub of CC2530 chip and CC2591 chip connected to a monitoring PC based on VC6.0 platform. Its experimental tests were carried out basing on the data collection accuracy and real time data transmission. Liang *et al.* (2013) also showed the equilibrium moisture model that was applied to develop a real time grain moisture content monitoring system based on wireless sensor network. The performance tests were taken on the transmission quality of sensors to realize stable data transmission which was worth for guaranteeing grain safety in storage. Furthermore, the real time monitoring of the grain storage system was designed based on ARM7 and using GSM/GPRS module as lower level Control unit which improved the level of grains storage. The communication between controller and WSN was accurately planned to avoid any interference in the design. The experimental results showed that grain condition intelligent monitoring system designed good features such as real time online detection, easy acquisition and good site stability which further provided flexibility, scalability, portability and security/integrity of the data transmission over long networks with lower power consumption (Vinayaka, 2016).

Khorgade and Dakhole (2015) presented the design of the granary environment storage monitoring system with embedded scheme based on ZigBee technology. It used the ARM7 transmission environment and multipoint acquisition module. Flexibility, cost and scalability of the system were successfully performed. Moreover, Changchun *et al.* (2009) designed a wireless sensor network central monitoring system with the structure of hierarchical network

topology for the environmental parameters' monitoring points. Essentially, it was designed for large scale grain depot facilities which were scattered. CC2430 chip based on ZigBee technology was applied as the heart of information processing and wireless nodes recognition. It detected information that was transferred to central monitoring computer in real time. The experimental test results showed that the system had the characteristics of good expansibility, networking flexibility and low cost. In another development, an intelligent grain condition monitoring and controlling system was designed (Gona and Venkateswarlu, 2015). The system had the lower machine control unit of an embedded ARM7 which was supported by the GSM technology. It used the multi-sensor unit to measure temperature, humidity as well as CO<sub>2</sub> and fire concentration. Testing was conducted utilizing the group of sensors in support of WSN for remote transmission. It was conducted for the purpose of confirming the system performance on scalability, flexibility, cost and effectiveness. Another study findings by Yuan (2015), revealed the black and white box testing experiments on the intelligent grain storage monitoring system for measuring humidity and temperature based on ZigBee technology for temperature and humidity. Basing on ZigBee technology, the system integrated the SCM and intelligent sensor technologies using STC89C52 as a control chip. The white box testing was done on the internal logic functions and the black one on the system functions. The experiments focused on the system accuracy, operational cost and stability. Furthermore, Zhang *et al.* (2010) proposed the design of the granary environment system based on short-range wireless transmission method for measuring temperature and humidity. Atmega128 microprocessor was applied for data processing while JN5139 wireless data transmission chip was used in facilitating the design of the node of wireless sensor network. Its ultra-low power and high integration help to reduce energy consumption. The test results indicated that the node of wireless monitor network based on the ZigBee technology used only a 3v battery to carry all communication activities.

In other studies like that of Lu *et al.* (2011), the design of monitoring system for condition of stored grain were also reported. The study used WSN technology for data transmission. The system proved successful for high stability, low cost, anti mould proof, low power consumption and light protection which guaranteed security efficiently. Yi and Bai (2011) also presented the design of humidity and temperature detecting granary system. The study utilized CC2530 and SHT15 digital sensor. It was implemented based on ZigBee protocol for data acquisition and transmission. The performance of the system was evaluated basing on node detection and real time protection. Along the same lines, Li and Xu (2012) proposed an

environment monitoring system based on ZigBee wireless sensor network with CC2530 chip. It applied AM2301 for measuring humidity and temperature in the grain storage. It used ZSensorMonitor to test real time environment information for cost protection and management automation.

However, there is no study that has been conducted to test the performance justification regarding the accuracy, precision and sturdiness of the system relating the grain temperature with humidity through the bulk of grains (Zhou *et al.*, 2008). Also there is no study that has been carried out on the performance of the models in real time on the effects of environmental parameters on dielectric properties of the crop grains. The implementation of poor storage methods (Chattha *et al.*, 2015; Kumar *et al.*, 2012; Onibonoje *et al.*, 2015) normally leads to tremendous post-harvest losses that affect food security. This forms the basis and interest for this study.

The objective of this study was to examine the performance of wheat grain storage technology based on ZigBee technology for monitoring the environmental parameters that influence the quality of wheat grain bulk in the storage facilities. It is crucial to properly evaluate the performance of the granary monitoring scheme for effectively measuring the environmental parameters to determine the quality of grains for ensuring food security. The above case can be achieved by performing the accuracy, precision, and robustness of the proposed method as previously argued by Wang (2012).

## **6.2 Methodology**

This section depicts the performance of the proposed model for monitoring the stored grains in the storage facility through wireless communication technology. The study proposed a three leg process method for evaluating the performance of the proposed model. The first leg was taken for evaluating the performance by examining the model robustness. During this measurement period, temperature and moisture were investigated with respect to dielectric and refractivity changes. In the second leg, the evaluation was performed looking at the accuracy of the model while monitoring the storage condition. To confirm the accuracy of the model, the comparison was done between the model and the commercial dip sensors. The final leg was due to the precision of the model in forecasting the storage condition of wheat grains. This based on the success and failure counts of the model.

The model has two main functions; first, to compute the environmental parameters such as moisture content and temperature in relation to the grain crops' electrical properties and secondly, to monitor the grain storage condition through forecasting scheme. Fig. 41 shows key elements of the model for monitoring the environmental parameters from the storage. The model takes the account of the user whose responsibility is to read the measured data from storage on the monitoring computer. A computer is used as the data analytical station for monitoring purposes, ZigBee network as the wireless medium from the storage to the monitoring computer, data processor as the module for signal modulation, sensor node as the data acquiring scheme from the storage and the cylindrical container as the wheat grain storage facility.

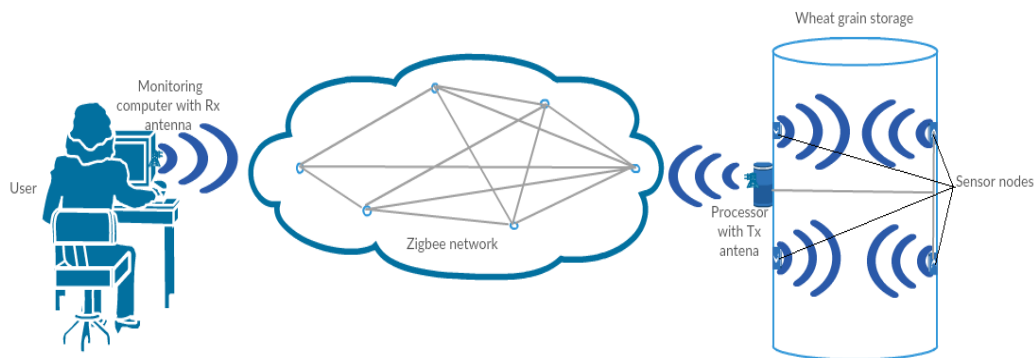

Figure 41: Schematics of the methodology of wheat storage condition monitoring model with ZigBee technology

### 6.2.1 Experiment setup

In order to confirm the model performance, the prototype was developed and tested. The experiment was conducted in two different environments at the Nelson Mandela African Institution of Science and Technology in Arusha, Tanzania (Tengeru campus) between May 2017 and July 2017. The first environment was in the greenhouse where the weather is usually controlled; the second was in open air area where the weather is often influenced by ambient condition. Moreover, commercial probes were used in parallel with the model prototype. The moisture content data obtained by commercial probes were taken on dry basis using equation (49) (Prakash *et al.*, 2004) to associate with data recorded by proposed method.

$$M_b = \frac{m_w}{100 - m_w} \times 100 \quad (49)$$

Where,  $M_b$  is moisture content on dry basis and  $m_w$  is the moisture content on wet basis.

The whole experiment surmised 4 primary levels of the model as detailed in Fig. 42 and appendix I. The model included sensing level at the storage facility for determining the environmental parameters in the storage such as moisture content and temperature, data transmission level through ZigBee wireless network, forecasting level for predicting the storage condition and the displaying level where the current data were being displayed for monitoring purposes. These levels explicated the essential standpoints of the model for monitoring the grains in the storage facility to ensure their quality against mycotoxins and poor germination.

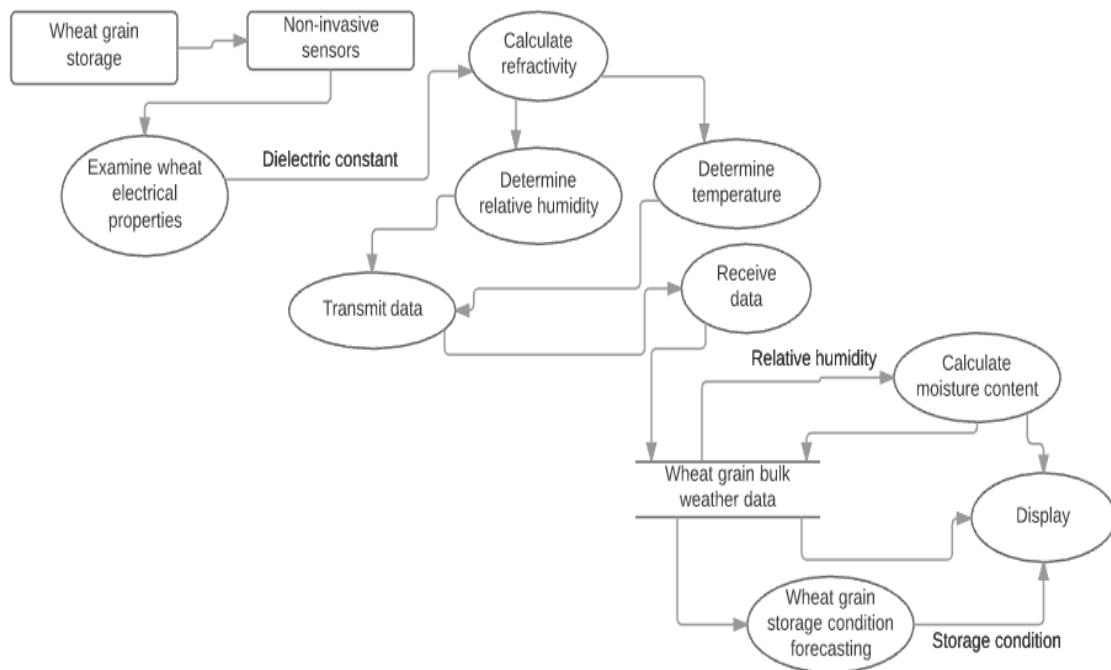

Figure 42: Schematic diagram of primary levels for the wheat storage condition monitoring model

In this work, two types of wheat grain crop (hard and soft wheat) were taken into account for temperature and moisture content monitoring in storage. They were stored in the cylindrical storage container of 250 dm<sup>3</sup> capacity as illustrated in Fig. 43. The experiment used non-invasive sensors (Polymer sensors with measuring frequency of 10 kHz) for determining relative humidity and the temperature. It also used the Arduino technique to process acquired data which were transmitted through ZigBee network to the monitoring computer. Then, the monitoring computer was used as a data analytical station for monitoring purposes as

demonstrated in Fig. 46. The entire storage container was divided into two layers (portions). The upper layer was termed as Layer 2 and bottom layer as Layer 1 to make data capturing activities practicable. The data for comparison were taken by commercial probes such as protimeter for moisture content measurements and thermocouple for temperature measurement. Both probes used to take measurements by being inserted into the grains during storage at a time model data were being recorded.



Figure 43: Wheat grains in the storage container



Figure 44: Greenhouse setup experiment

The performance evaluation of this study was carried out to check the ability of the model to accurately measure the environment parameters in the storage, its robustness over the effect of environmental parameters on the dielectric properties of wheat grains under the actual storing in the storage container. Towards this confirmation, the study applied the Looyenga equation (52) (Nathan and Lo, 2010) for water activity with dielectric property.



Figure 45: Open air space setup



Figure 46: Monitoring computers displaying received data

The experiment was taken on different parameters; controlled and non-controlled environments in order to confirm the model performance over its robustness as illustrated in Fig. 44 and 45 respectively. The parameters included relative humidity, moisture content, temperature, dielectric constant, refractivity and the storage forecasted status. Data from the model and the commercial dip sensors were compared in order to portray the accuracy of the model. The comparison of the two technologies was taken only in the non-controlled environment (open air area). The assumption was that the surrounding was best area for examining the stability and accuracy of the model due to the influence of the high variation caused by ambient condition. The study applied equation (50) (Greenspan, 2011) to evaluate the accuracy of the proposed method. The probe data was taken as the actual values (A) while the model data as the measured values (M). Moreover, equation (51) (Tataarty, 2011) was used to evaluate the precision of the model to check the success



and failure in grain storage condition prediction. The success of prediction was taken as the true value (T) while its failure was taken as the false value (F).

$$\text{Accuracy absolute error} = \frac{M-A}{A} \quad (50)$$

$$\text{Precision} = \frac{T}{T+F} \quad (51)$$

Throughout the experiment, temperature, relative humidity and moisture content measurements were performed after 24 hours. The sensor readings were processed by Arduino module at the storage, and then transmitted to the monitoring station remotely through ZigBee network. At the monitoring computer, the data were analyzed for monitoring purposes.

$$\varepsilon_b = \left\{ \gamma \left( \varepsilon_w^{1/3} - \varepsilon_g^{1/3} \right) + \varepsilon_g^{1/3} \right\}^3 \quad (52)$$

Where,  $\gamma$  is the volume fraction of water in the grain bulk,  $\varepsilon_b$  current dielectric constant of the wheat grains,  $\varepsilon_w$  dielectric constant of water and  $\varepsilon_g$  optimal dielectric constant of wheat.

## 6.3 Results and discussions

This section explains experimental results. Section 6.3.1 demonstrates the results on the model robustness in determining humidity, moisture content and temperature. Section 6.3.2 includes the accuracy of the model. Lastly, section 6.3.3 shows the precision of the model over the forecasted wheat storage condition.

### 6.3.1 Model Robustness

The results of the two wheat varieties (hard and soft) during storage in the greenhouse environment for 25 days are compared and presented in Fig. 47 to 53. Temperature measurements of storages are also compared as indicated in Fig. 47. Both wheat grain storages were placed in the greenhouse. The results show that both experienced temperature variations. Soft wheat grains were more affected than the hard wheat storage. This was due to the loss of moisture content in grains as confirmed in Fig. 49 caused by the drop of relative humidity in the storage as confirmed in Table 6. From Fig. 47 and 50, it was observed that the model was able to react to any change occurred in the storage.

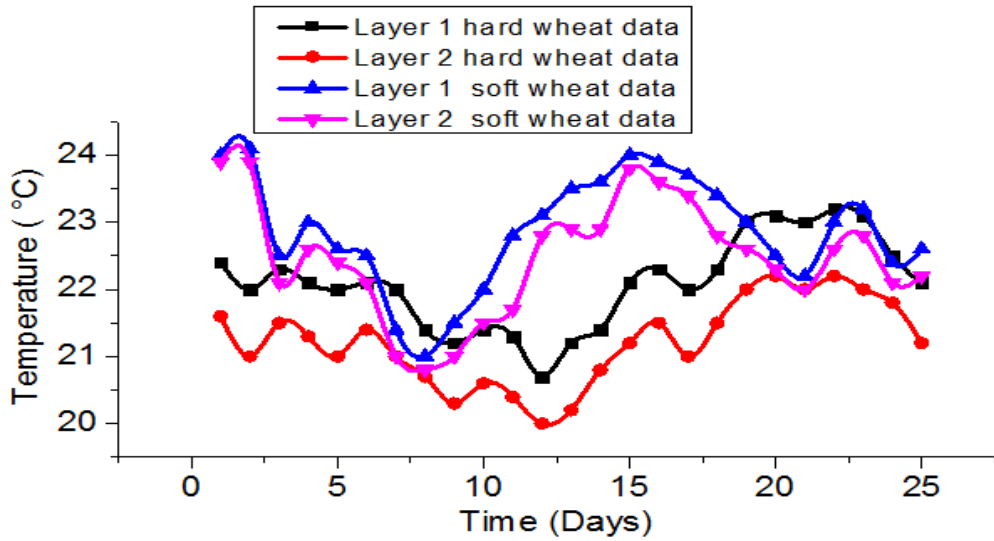

Figure 47: Daily variations of wheat grain storage temperature in the greenhouse

Also, Fig. 48 shows the variation of moisture content during the storage period. The results indicated clearly that relative humidity was more in the hard wheat storage almost the entire period of storage compared to the soft wheat storage. The situation was caused by the decline in temperature during hard wheat grain storage as justified in Fig. 47. The above situation was previously reported by Magan and Aldred (2007) that the moisture content in the storage of both wheat grains varied frequently with time in safe region except for the hard wheat layer 2 in day 9 and 12 as shown in Fig. 48 and Table 6. This was due to the lower temperatures as exhibited in Fig. 47. The results also showed that moisture content data had the decreasing tendency for both species of wheat as the temperature advanced. This was due to the drop in relative humidity as shown in Table 6 and 7.

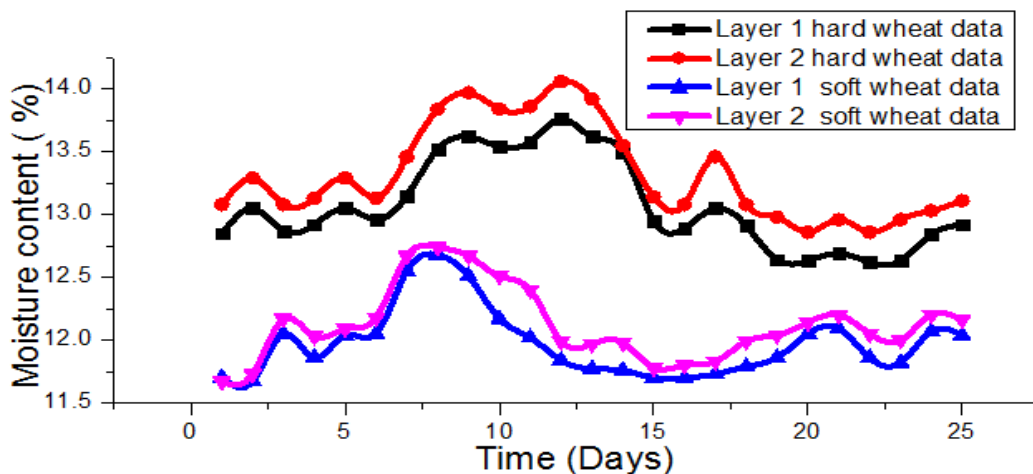

Figure 48: Daily variation of wheat storage moisture content in the greenhouse

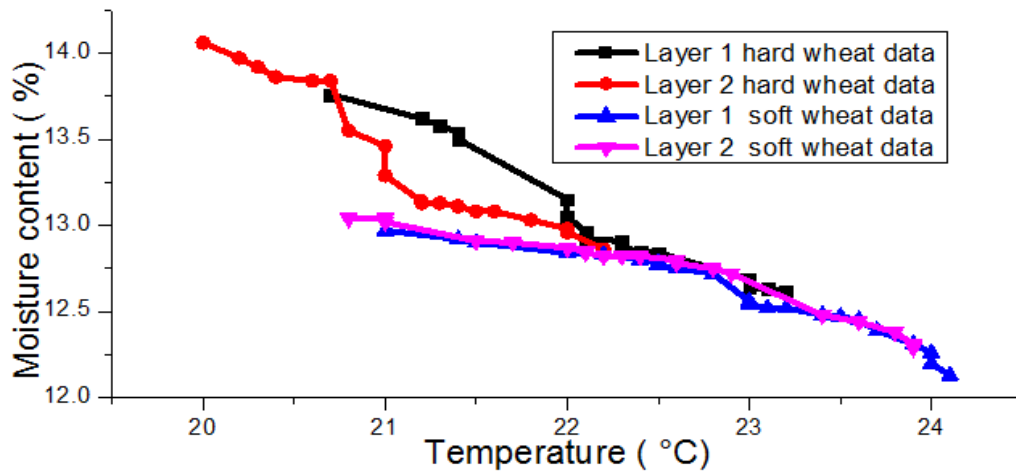

Figure 49: Storage temperature as the function of wheat storage moisture content in the greenhouse

During wheat storage, at lower temperatures, the dielectric constant was higher for both wheat species. But as the temperature rose, the dielectric constant decreased. However, the results exhibited a significant difference at higher temperatures. This might be due to the effect of heat on oriental polarization to the dielectric products as it was earlier reported by Doitpoms (2015). Moreover to both stored wheat types, the moisture content had a significant effect on the dielectric properties at lower temperatures than at higher temperatures as shown in Fig. 50. The above situation was also reported by Tomaraei (2010). Fig. 51 demonstrates the relationship between the relative humidity and moisture content in the wheat storage for hard and soft wheat. The isotherms of both species are similar as moisture content increases the relative humidity. This was due to the reason that relative humidity is the amount of moisture content compared to the saturation point at a particular temperature. However, the relationship seemed to be increasing significantly in hard wheat storage at higher relative humidity due to the great drop in temperature during hard wheat storage as exhibited in Fig. 47.

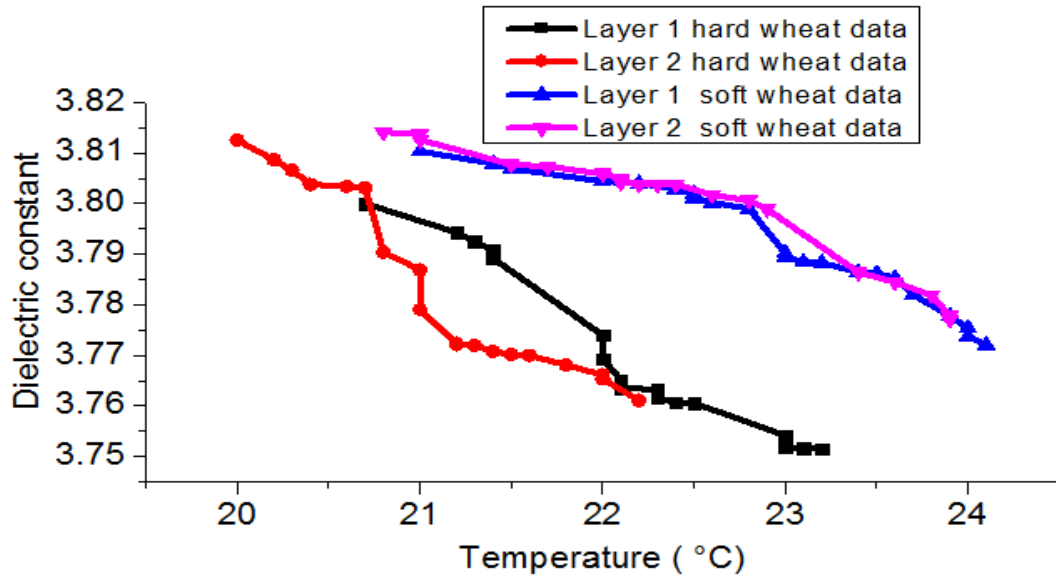

Figure 50: The effect of temperature on the dielectric constant of the stored wheat grains in the greenhouse environment

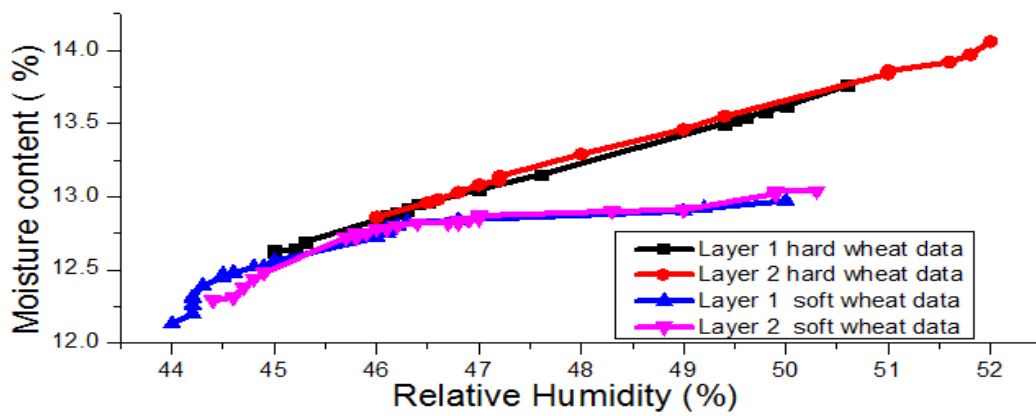

Figure 51: The relationship of wheat storage moisture content and relative humidity in the greenhouse

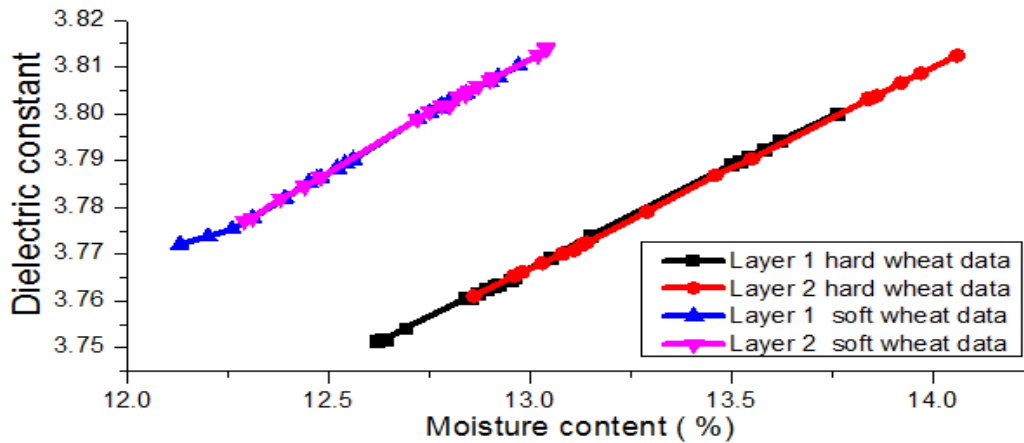

Figure 52: Wheat storage moisture content as the function of dielectric constant in the greenhouse environment

It was found that the change in moisture content caused the significant change in dielectric constant. This was due to the fact that dielectric constant usually tends to increase rapidly at lower frequency as the model frequency of 10 KHz is lower one. This was previously reported by Tomaraei (2010) as illustrated in Fig. 52. The variation of the refractivity also showed an increase as the moisture content increased as illustrated in Fig. 53. Its variation was in the response to dielectric change due to any change in the moisture content in the bulk of wheat grains during storage.

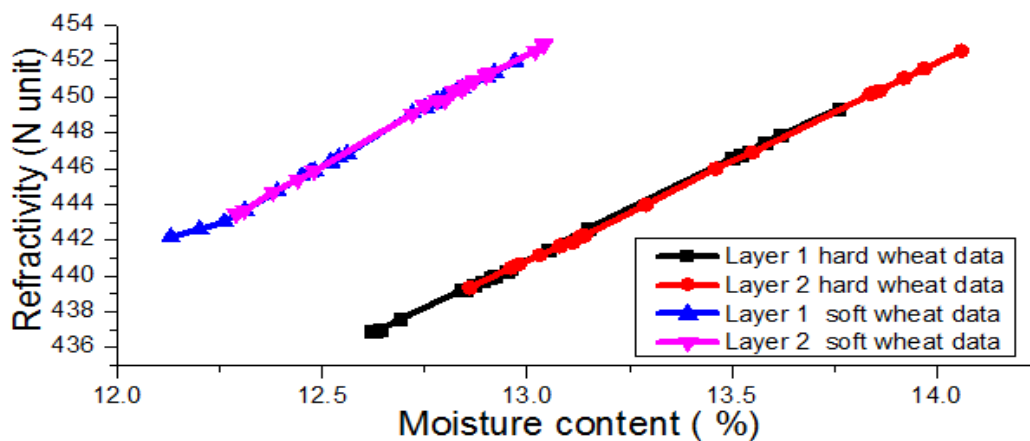

Figure 53: Wheat storage moisture content as the function refractivity in the greenhouse

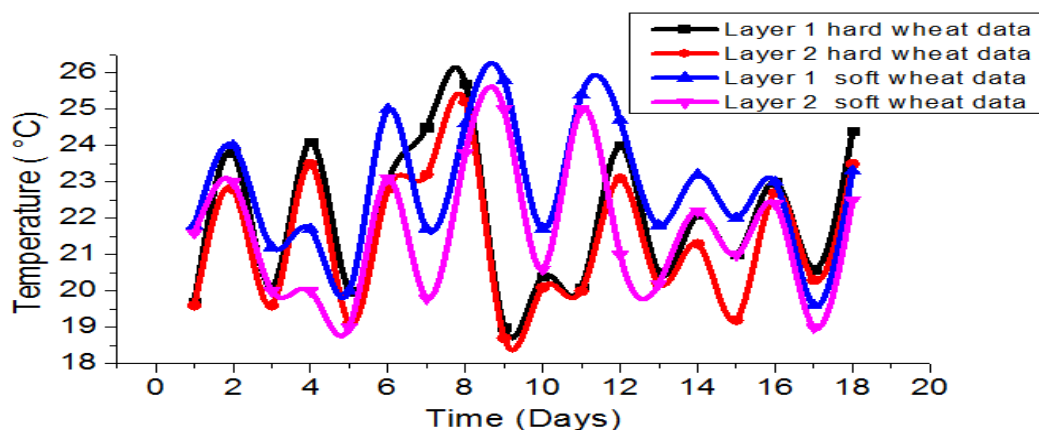

Figure 54: Daily variations of wheat grain storage temperature in the open air area

Moreover, the results between two wheat varieties (hard and soft) during storage in the open air environment for 18 days were also compared and presented in Fig. 54 to 59. A comparison of temperatures during storage period for soft and hard wheat grain storages is illustrated in Fig. 54. In both wheat species, the frequent variation was observed. The trend was totally different from what was observed during storage in the greenhouse. The difference was that temperature rapidly varied with time. This was due to the influence of ambient conditions.

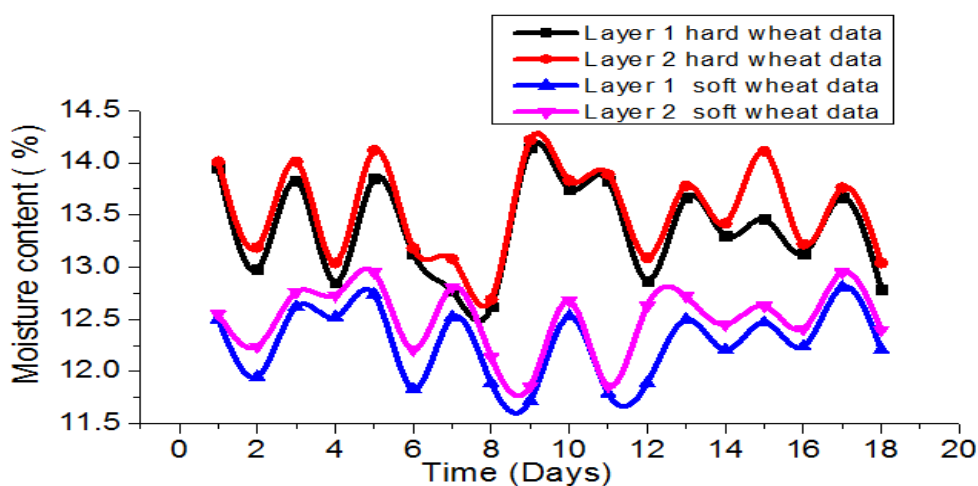

Figure 55: Daily variation of wheat storage moisture content in the open air area

Table 6: Hard wheat grains experiment data measured by the proposed technology during storage in the greenhouse

Time	Temperature	Relative Humidity	Moisture content	Dielectric constant	Refractivity	Temperature	Relative Humidity	Moisture content	Dielectric constant	Refractivity
(Days)	(°C)	(%)	(%)		(N unit)	(°C)	(%)	(%)		(N unit)
	Layer1	Layer1	Layer1	Layer1	Layer1	Layer2	Layer2	Layer2	Layer2	Layer2
1	22.40	46.00	12.85	3.760 7	439.261 8	21.60	47.00	13.08	3.770 0	441.658 8
2	22.00	47.00	13.05	3.769 3	441.465 6	21.00	48.00	13.29	3.779 1	443.985 3
3	22.30	46.10	12.87	3.761 7	439.509 0	21.50	47.00	13.08	3.770 2	441.708 7
4	22.10	46.30	12.92	3.763 6	440.005 0	21.30	47.20	13.13	3.772 2	442.214 3
5	22.00	47.00	13.05	3.769 3	441.465 6	21.00	48.00	13.29	3.7791	443.985 3
6	22.10	46.50	12.96	3.765 2	440.409 2	21.40	47.20	13.13	3.772 0	442.163 0
7	22.00	47.60	13.15	3.774 0	442.674 9	21.00	49.00	13.46	3.786 9	445.995 3
8	21.40	49.50	13.52	3.790 0	446.786 3	20.70	51.00	13.84	3.803 1	450.162 9
9	21.20	50.00	13.62	3.794 3	447.891 3	20.30	51.60	13.97	3.808 7	451.592 7
10	21.40	49.60	13.54	3.790 8	446.986 5	20.60	51.00	13.84	3.803 4	450.220 1
11	21.30	49.80	13.58	3.792 5	447.438 7	20.40	51.00	13.86	3.803 8	450.337 1
12	20.70	50.60	13.76	3.800 0	449.364 6	20.00	52.00	14.06	3.812 5	452.573 7
13	21.20	50.00	13.62	3.794 3	447.891 3	20.20	51.80	13.92	3.806 6	451.055 8
14	21.40	49.40	13.50	3.789 2	446.586 0	20.80	49.40	13.55	3.790 4	446.907 5
15	22.10	46.40	12.95	3.764 6	440.253 8	21.20	47.20	13.14	3.772 4	442.266 3
16	22.30	46.20	12.89	3.762 5	439.711 2	21.50	47.00	13.08	3.770 2	441.708 7
17	22.00	47.00	13.05	3.769 3	441.465 6	21.00	49.00	13.46	3.786 9	445.995 3
18	22.30	46.30	12.91	3.763 3	439.913 4	21.50	47.00	13.08	3.770 2	441.708 7
19	23.00	45.20	12.64	3.751 9	436.978 3	22.00	46.60	12.98	3.766 2	440.658 0
20	23.10	45.00	12.63	3.751 7	436.937 1	22.20	46.00	12.86	3.761 1	439.352 1
21	23.00	45.30	12.69	3.754 2	437.586 4	22.00	46.50	12.96	3.765 4	440.455 9
22	23.20	45.00	12.62	3.751 6	436.896 3	22.20	46.00	12.86	3.761 1	439.352 1
23	23.10	45.00	12.63	3.751 7	436.937 1	22.00	46.50	12.96	3.765 4	440.455 9
24	22.50	46.00	12.84	3.760 6	439.217 4	21.80	46.80	13.03	3.768 1	441.157 2
25	22.10	46.30	12.92	3.763 6	440.005 0	21.20	47.20	13.11	3.770 8	441.862 5

Table 7: Soft wheat grains experiment data measured by the proposed technology during storage in the greenhouse

Time	Temperature	Relative Humidity	Moisture Content	Dielectric Constant	Refractivity	Temperature	Relative Humidity	Moisture Content	Dielectric Constant	Refractivity
(Days)	(°C)	(%)	(%) d.b		(N unit)	(°C)	(%)	(%) d.b		(N unit)
	Layer1	Layer1	Layer1	Layer1	Layer1	Layer2	Layer2	Layer2	Layer2	Layer2
1	24.00	44.20	11.70	3.744 1	434.962 5	23.90	44.60	11.67	3.747 4	435.811 5
2	24.10	44.00	11.67	3.742 4	434.519 3	23.80	44.40	11.74	3.745 9	435.443 7
3	22.50	46.10	12.05	3.767 5	439.419 7	22.10	46.80	12.17	3.805 0	441.015 1
4	23.00	45.00	11.86	3.760 4	436.978 3	22.60	46.00	12.03	3.801 7	439.173 6
5	22.60	46.10	12.04	3.763 9	439.375 8	22.40	46.40	12.09	3.803 8	440.070 5
6	22.50	46.10	12.05	3.768 3	439.419 7	22.10	46.90	12.18	3.804 2	441.217 0
7	21.40	49.20	12.55	3.793 9	446.185 2	21.00	49.90	12.67	3.812 6	447.798 7
8	21.00	50.00	12.68	3.797 5	447.998 7	20.80	50.30	12.74	3.813 8	448.708 9
9	21.50	49.00	12.51	3.793 9	445.733 1	21.00	49.90	12.67	3.814 1	447.798 7
10	22.00	46.80	12.17	3.785 9	441.061 9	21.50	49.00	12.51	3.807 7	445.733 1
11	22.80	46.00	12.02	3.780 0	439.087 3	21.70	48.30	12.40	3.807 3	444.227 8
12	23.10	44.90	11.84	3.758 5	436.734 3	22.80	45.80	11.99	3.800 6	438.682 8
13	23.50	44.50	11.77	3.757 5	435.762 5	22.90	45.70	11.97	3.798 9	438.438 1
14	23.60	44.50	11.76	3.758 3	435.723 5	22.90	45.80	11.98	3.798 9	438.640 4
15	24.00	44.20	11.70	3.748 3	434.962 5	23.80	44.70	11.78	3.781 9	436.052 2
16	23.90	44.20	11.70	3.749 4	435.000 0	23.60	44.80	11.80	3.784 5	436.332 0
17	23.70	44.30	11.73	3.750 5	435.279 0	23.40	44.90	11.83	3.786 4	436.613 3
18	23.40	44.60	11.79	3.758 5	436.004 8	22.80	45.80	11.99	3.800 6	438.682 8
19	23.00	45.00	11.86	3.761 2	436.978 3	22.60	46.10	12.04	3.801 7	439.375 8
20	22.50	46.10	12.05	3.766 4	439.419 7	22.30	46.70	12.14	3.803 8	440.721 4
21	22.20	46.30	12.09	3.769 3	439.958 9	22.00	47.00	12.20	3.805 9	441.465 6
22	23.00	45.00	11.86	3.762 0	436.978 3	22.60	46.20	12.05	3.801 7	439.577 9
23	23.20	44.80	11.82	3.759 3	436.490 7	22.80	45.90	12.00	3.800 6	438.885 1
24	22.40	46.20	12.07	3.769 1	439.666 3	22.10	47.00	12.20	3.804 2	441.418 7
25	22.60	46.10	12.04	3.767 4	439.375 8	22.20	46.80	12.16	3.803 8	440.968 9



The moisture content fluctuations with time are shown in Fig. 55. It was noticed that any change in relative humidity influenced the change in moisture content as indicated in Table 8 and 9. The high frequency of fluctuation observed was due to the influence of ambient condition and wheat respiration only as there was no sign of insect infestation in the storage. The above findings were also presented by Jian and Jayas (2011) and Sawant *et al.* (2012). Fig. 56 demonstrates the relationship between moisture content and temperature during wheat grain storage in open air environment. The condition decreased as the temperature increased. This trend was similar as that observed during the storage in the greenhouse as demonstrated in Fig. 49. However, the above tendency seemed to be ruthless to hard wheat than to soft wheat with more moisture content. This was due to the high decrease in temperature during hard wheat grain storage. The dielectric constant of stored wheat grains is shown in Fig. 57. Dielectric constant was examined on all samples during storage. The decreasing effect was observed as the temperature advanced. The effect appeared to be similar in almost all samples. This was due to the frequent change in moisture content and relative humidity with temperature as exhibited in Table 8 and 9.

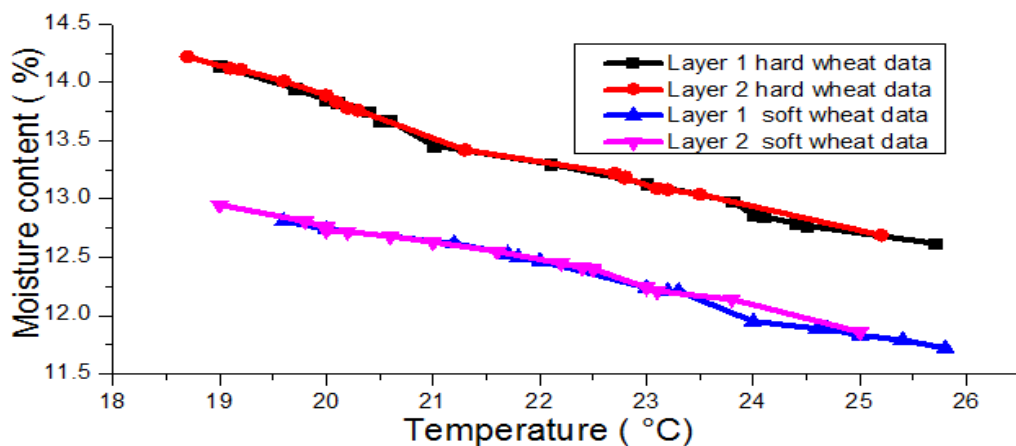

Figure 56: Wheat storage temperature as the function of moisture content in the open air area

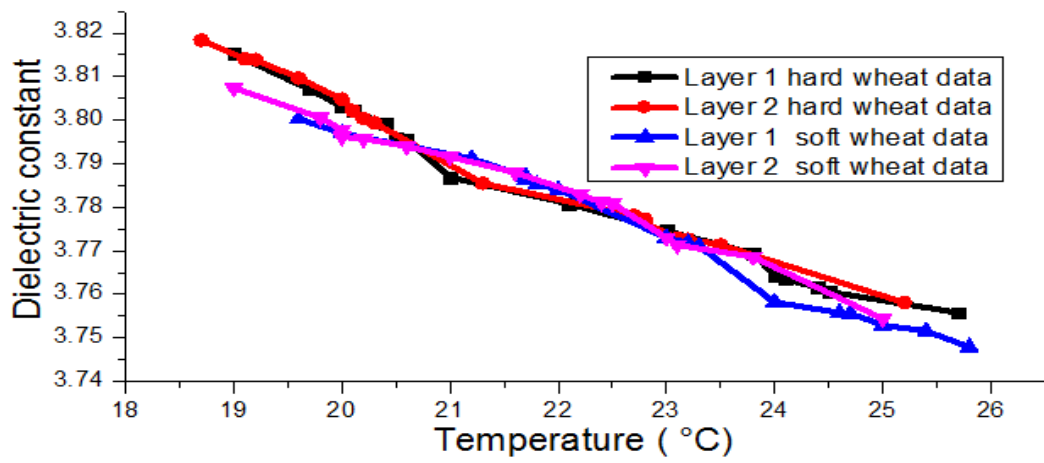

Figure 57: Effect of temperature on the dielectric constant during wheat storage in the open air area

Table 8: Hard wheat grains experiment data measured by the proposed technology during storage in the open area

Hard Wheat Storage										
Time	Temperature	Relative Humidity	Moisture content	Dielectric constant	Refractivity	Temperature	Relative Humidity	Moisture content	Dielectric constant	Refractivity
(Days)	(°C)	(%)	(%)		(N unit)	(°C)	(%)	(%)		(N unit)
	Layer 1	Layer 1	Layer 1	Layer 1	Layer 1	Layer 2	Layer 2	Layer 2	Layer 2	Layer 2
1	19.70	51.20	13.95	3.807	1 451.174	0 19.60	51.50	14.01	3.809	7 451.838
2	23.80	47.40	12.98	3.769	4 441.500	3 22.80	48.20	13.19	3.777	3 443.518
3	20.10	50.70	13.83	3.802	2 449.920	4 19.60	51.50	14.01	3.809	7 451.838
4	24.10	46.70	12.85	3.763	5 439.977	2 23.50	47.60	13.04	3.771	4 442.021
5	20.00	50.80	13.85	3.803	2 450.182	5 19.10	51.90	14.12	3.814	1 452.983
6	23.00	47.90	13.13	3.774	6 442.830	7 22.80	48.10	13.18	3.776	5 443.318
7	24.50	46.40	12.77	3.760	6 439.224	3 23.20	47.70	13.08	3.772	7 442.345
8	25.70	46.00	12.62	3.755	8 437.998	2 25.20	46.20	12.69	3.758	1 438.571
9	19.00	52.00	14.14	3.815	2 453.256	2 18.70	52.30	14.22	3.818	4 454.079
10	20.40	50.40	13.75	3.799	1 449.139	1 20.10	50.70	13.83	3.802	2 449.139
11	20.10	50.70	13.83	3.802	2 449.920	4 20.00	51.00	13.89	3.804	8 450.581
12	24.00	46.80	12.87	3.764	4 440.216	6 23.10	47.70	13.09	3.772	9 442.386
13	20.50	50.00	13.67	3.795	8 448.280	4 20.20	50.50	13.78	3.800	4 449.459
14	22.10	48.50	13.30	3.780	8 444.437	0 21.30	48.90	13.42	3.785	5 445.635
15	21.00	49.00	13.46	3.786	9 445.995	3 19.20	51.90	14.11	3.813	9 452.911
16	23.00	47.90	13.13	3.774	6 442.830	7 22.70	48.30	13.22	3.778	2 443.763
17	20.60	50.00	13.67	3.795	6 448.222	5 20.30	50.40	13.76	3.799	4 449.198
18	24.40	46.50	12.79	3.761	5 439.462	3 23.50	47.60	13.04	3.771	4 442.021

Table 9: Soft wheat grains experiment data measured by the proposed technology during storage in the open area

Soft Wheat Storage										
Time	Temperature	Relative Humidity	Moisture content	Dielectric constant	Refractivity	Temperature	Relative Humidity	Moisture content	Dielectric constant	Refractivity
(Days)	(°C)	(%)	(%)		(N unit)	(°C)	(%)	(%)		(N unit)
	Layer 1	Layer 1	Layer 1	Layer 1	Layer 1	Layer 2	Layer 2	Layer 2	Layer 2	Layer 2
1	21.80	49.00	12.50	3.785 3	445.583 8	21.60	49.30	12.55	3.788 0	446.284 0
2	24.00	46.00	11.95	3.758 2	438.604 9	23.00	47.70	12.24	3.773 0	442.428 9
3	21.20	49.60	12.62	3.791 2	447.090 9	20.00	50.10	12.76	3.797 8	448.783 5
4	21.70	49.10	12.52	3.786 3	445.833 4	20.00	49.90	12.73	3.796 2	448.383 1
5	20.00	50.00	12.74	3.797 0	448.583 3	19.00	51.00	12.95	3.807 4	451.264 3
6	25.00	45.50	11.83	3.752 9	437.231 9	23.10	47.50	12.21	3.771 3	441.984 7
7	21.70	49.10	12.52	3.786 3	445.833 4	19.80	50.40	12.81	3.800 6	449.511 3
8	24.60	45.80	11.89	3.755 8	437.979 2	23.80	47.30	12.14	3.768 6	441.299 4
9	25.80	45.00	11.72	3.747 9	435.951 4	25.00	45.70	11.86	3.754 4	437.635 1
10	21.70	49.20	12.53	3.787 0	446.033 9	20.60	49.80	12.68	3.794 0	447.822 1
11	25.40	45.40	11.79	3.751 6	436.892 2	25.00	45.70	11.86	3.754 4	437.635 1
12	24.70	45.80	11.89	3.755 6	437.943 2	21.00	49.60	12.63	3.791 6	447.198 1
13	21.80	49.00	12.50	3.785 3	445.583 8	20.20	49.90	12.72	3.795 7	448.259 3
14	23.20	47.50	12.21	3.771 1	441.943 1	22.20	48.80	12.45	3.783 0	444.992 1
15	22.00	48.90	12.47	3.784 1	445.286 8	21.00	49.60	12.63	3.791 6	447.198 1
16	23.00	47.70	12.24	3.773 0	442.428 9	22.40	48.60	12.41	3.781 1	444.499 0
17	19.60	50.30	12.81	3.800 3	449.443 3	19.00	51.00	12.95	3.807 4	451.264 3
18	23.30	47.60	12.21	3.771 8	442.102 8	22.50	48.60	12.40	3.780 9	444.453 8

Table 10: Comparison of hard wheat storage data measured by the proposed method and probes

<b>Hard Wheat Storage</b>								
<b>Model Data</b>					<b>Dip Sensor Data</b>			
<b>Time</b>	<b>Temperature</b>	<b>Moisture</b>	<b>Temperature</b>	<b>Moisture</b>	<b>Temperature</b>	<b>Moisture</b>	<b>Temperature</b>	<b>Moisture</b>
<b>(Days)</b>	<b>(°C)</b>	<b>(%) d.b</b>	<b>(°C)</b>	<b>(%) d.b</b>	<b>(°C)</b>	<b>(%) d.b</b>	<b>(°C)</b>	<b>(%) d.b</b>
	<b>Layer 1</b>	<b>Layer 1</b>	<b>Layer 2</b>	<b>Layer 2</b>	<b>Layer 1</b>	<b>Layer 1</b>	<b>Layer 2</b>	<b>Layer 2</b>
1	19.70	13.95	19.60	14.01	20.00	14.00	20.00	13.80
2	23.80	12.98	22.80	13.19	22.30	13.00	23.00	13.00
3	20.10	13.83	19.60	14.01	21.00	13.60	20.00	14.00
4	24.10	12.85	23.50	13.04	24.00	12.70	23.20	13.00
5	20.00	13.85	19.10	14.12	19.30	13.60	19.00	14.00
6	23.00	13.13	22.80	13.18	23.40	13.00	22.00	13.00
7	24.50	12.77	23.20	13.08	24.00	12.40	24.00	13.00
8	25.70	12.62	25.20	12.69	25.00	12.40	25.00	12.50
9	19.00	14.14	18.70	14.22	20.00	14.00	19.00	14.10
10	20.40	13.75	20.10	13.83	21.00	13.50	20.20	13.60
11	20.10	13.83	20.00	13.89	20.00	13.60	21.00	13.70
12	24.00	12.87	23.10	13.09	25.00	13.00	24.00	13.00
13	20.50	13.67	20.20	13.78	20.00	13.50	20.00	13.60
14	22.10	13.30	21.30	13.42	22.00	13.00	22.00	13.10
15	21.00	13.46	19.20	14.11	22.00	13.10	20.00	14.00
16	23.00	13.13	22.70	13.22	24.00	13.00	23.00	13.10
17	20.60	13.67	20.30	13.76	21.00	13.50	21.00	13.50
18	24.40	12.79	23.50	13.04	24.00	12.50	24.00	13.00

Table 11: Comparison of soft wheat storage data measured by the proposed method and dip sensors

Soft Wheat Storage								
Time (Days)	Model Data				Dip Sensor Data			
	Temperature	Moisture Content	Temperature	Moisture Content	Temperature	Moisture Content	Temperature	Moisture Content
	(°C)	(%) d.b	(°C)	(%) d.b	(°C)	(%) d.b	(°C)	(%) d.b
	Layer 1	Layer 1	Layer 2	Layer 2	Layer 1	Layer 1	Layer 2	Layer 2
1	21.80	12.50	21.60	12.55	22.00	12.00	22.00	12.20
2	24.00	11.95	23.00	12.24	23.00	12.40	24.10	12.30
3	21.20	12.62	20.00	12.76	20.00	12.20	19.60	12.50
4	21.70	12.52	20.00	12.73	21.00	12.40	21.00	12.50
5	20.00	12.74	19.00	12.95	20.00	12.30	20.00	12.70
6	25.00	11.83	23.10	12.21	25.10	11.50	23.00	12.00
7	21.70	12.52	19.80	12.81	22.00	12.30	20.30	12.60
8	24.60	11.89	23.80	12.14	25.00	11.50	23.00	12.00
9	25.80	11.72	25.00	11.86	26.00	11.60	25.80	11.60
10	21.70	12.53	20.60	12.68	22.00	12.20	21.00	12.10
11	25.40	11.79	25.00	11.86	25.00	11.30	25.50	11.30
12	24.70	11.89	21.00	12.63	24.00	11.60	20.00	12.30
13	21.80	12.50	20.20	12.72	21.00	12.10	21.00	12.60
14	23.20	12.21	22.20	12.45	23.00	12.30	23.00	12.00
15	22.00	12.47	21.00	12.63	21.50	12.10	22.30	12.60
16	23.00	12.24	22.40	12.41	24.00	12.00	21.60	12.30
17	19.60	12.81	19.00	12.95	21.00	12.60	20.00	13.00
18	23.30	12.21	22.50	12.40	24.00	12.00	23.00	12.40

The relationship between the moisture content and dielectric constant is shown in Fig. 58. The effect of moisture content on the dielectric constant was observed as the relative humidity changed (Table 8 and 9). In fact, the increase in relative humidity was due to the environmental condition variations as presented earlier by Sawant *et al.* (2012). The situation caused fluent change in moisture content that affects grains' dielectric constant as it was reported earlier by Tomaraei (2010).

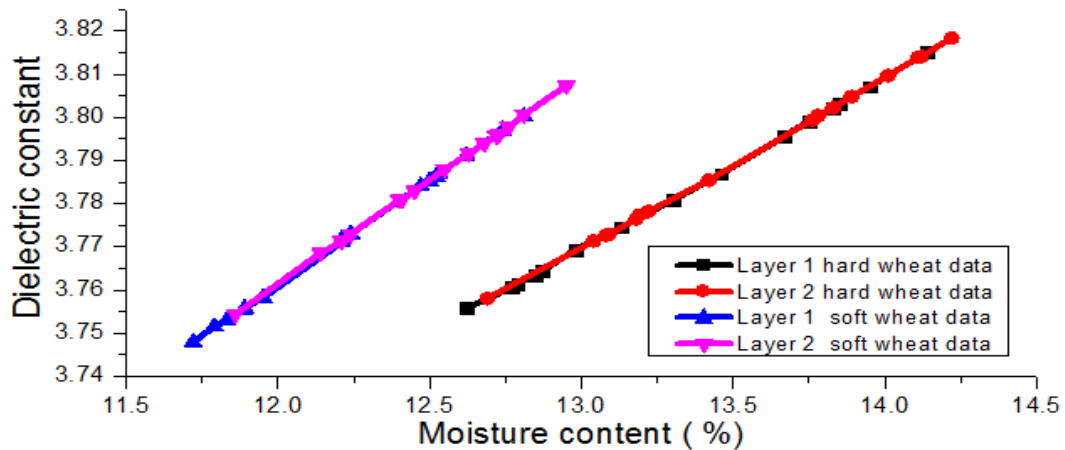

Figure 58: The effect of moisture content on the dielectric constant during wheat storage in the open air area

There was an articulating similarity in the change of moisture content with refractivity for both wheat storages as illustrated in Fig. 59. Though the attribute was the same to both, the refractivity was affected more by higher moisture content. Refractivity was observed to increase steadily as moisture content increased as it was previously reported by Edet (2017). The daily variation of refractivity indicated the strong dependence on moisture content amount in stored grains as shown in Table 8 and 9. High refractivity was observed during hard wheat storage than in soft what storage due to the drop of temperature during hard wheat grain storage as demonstrated in Fig. 59.

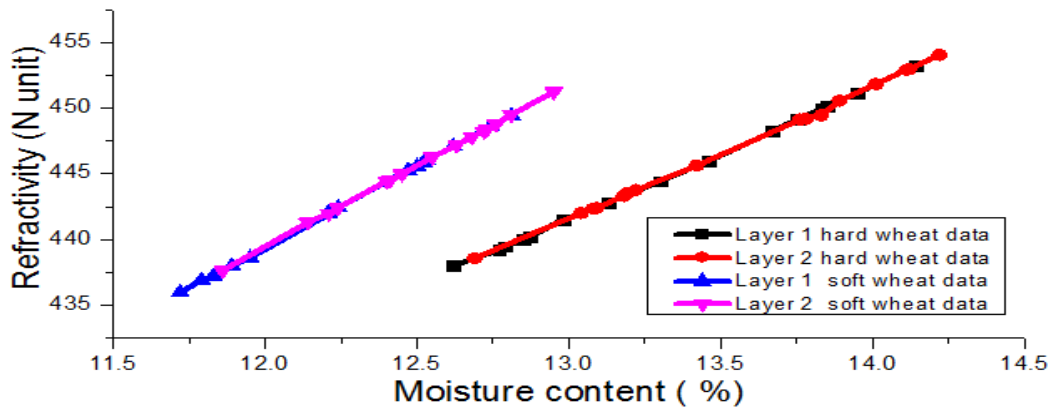

Figure 59: Moisture content as the function of refractivity during storage period of wheat in the open air area

### 6.3.2 Model Accuracy

This section of the study explicates the comparison of the measurements taken between the proposed method and the commercial probes during the storage of wheat grain in the open environment for 18 days as depicted in Fig. 60 to 67 (as well as in Table 10 and 11). Storage temperature of stored hard and soft wheat grains by both methods are presented in Fig. 60 and 64 respectively. The measured data by both methods in each layer emerged to be almost the same. The results for the variation of moisture content in hard and soft wheat stored grains are also clearly shown in Fig. 62 and 66 respectively. The distribution of moisture content in each layer was almost the same despite a very little dispersion that was observed in Fig. 62 and in layer 1 as depicted in Fig. 66. Furthermore, when the comparison was done, only a small difference was found between the model and probe data in both storages (hard and soft wheat grain storages). The findings from the hard wheat storage on the accuracy showed that relative error in layer 1 for temperature measurement was between -5 to 6.73% and in layer 2 was between -4.76 to 3.74% as shown in Fig. 61 and Table 12. Also the relative error for moisture content measurement was between -1 to 2.98% in layer 1 and 0.07 to 2.44% in layer 2 as shown in Fig. 63 and in Table.12. Besides, the findings from soft wheat storage showed the relative error between -6.67 to 6% in layer 1 and -5.83 to 3.7% in layer 2 for temperature measurement shown in Fig. 65 and Table 13. Relative error for moisture measurements was also found between -3.63 to 4.34% in layer 1 and -0.49 to 4.96% in layer 2 as depicted in Fig. 67. Hence, almost the experimental data collected were in agreement to the designed model as per the evidence provided above. However, since these errors were minimal, they did not disturb the monitoring process of the storage.



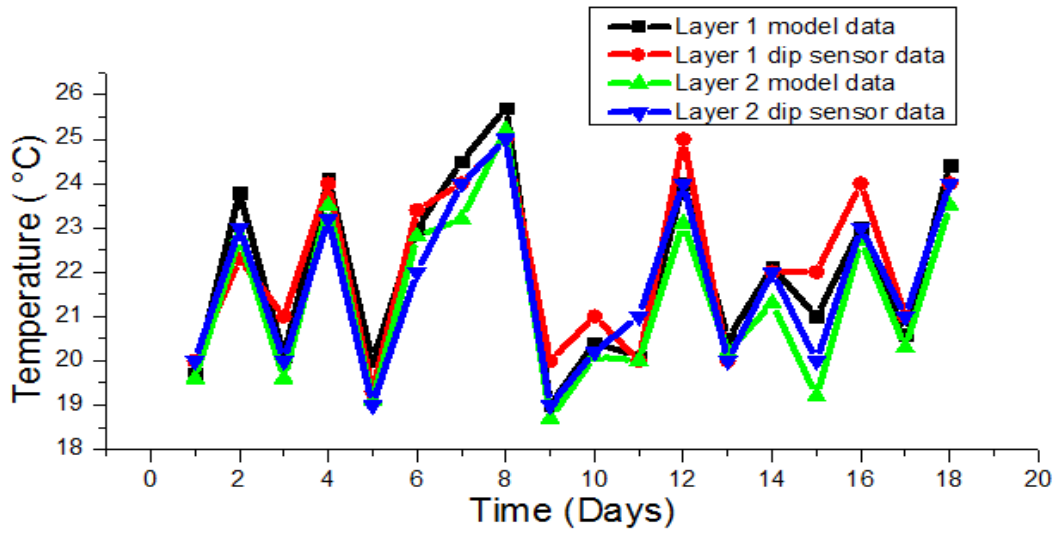

Figure 60: Daily variation of hard wheat storage temperature by the model and probes in the open air environment

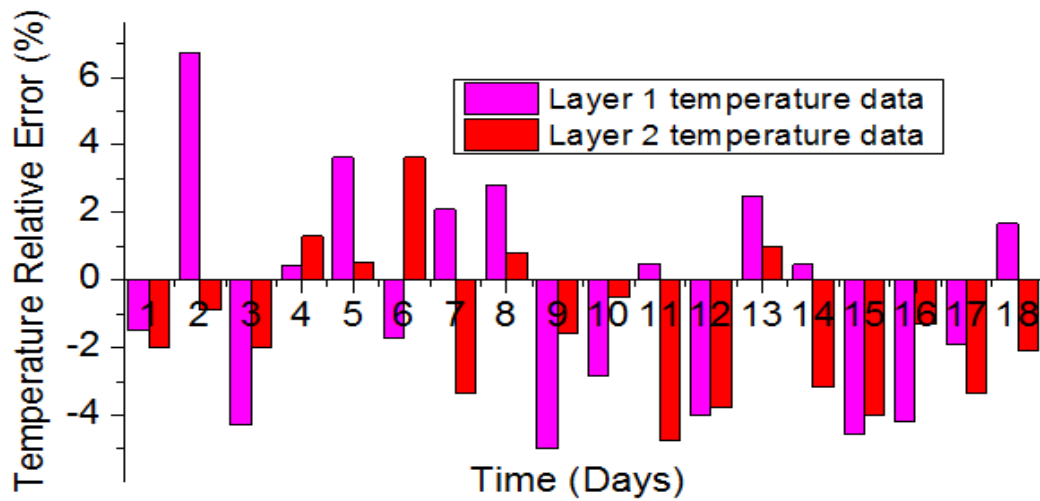

Figure 61: Model relative error in capturing temperature data from the hard wheat storage

Table 12: Accuracy relative error of the hard wheat data measured by the proposed model and dip sensor during storage in the open air area

<b>Time</b>	<b>Temperature Absolute Error</b>	<b>Temperature Absolute Error</b>	<b>Temperature Relative Error</b>	<b>Temperature Relative Error</b>	<b>Moisture Content Absolute Error</b>	<b>Moisture Content Absolute Error</b>	<b>Moisture Content Relative Error</b>	<b>Moisture Content Relative Error</b>
<b>(Days)</b>			<b>(%)</b>	<b>(%)</b>			<b>(%)</b>	<b>(%)</b>
	<b>Layer 1</b>	<b>Layer 2</b>	<b>Layer 1</b>	<b>Layer 2</b>	<b>Layer 1</b>	<b>Layer 2</b>	<b>Layer 1</b>	<b>Layer 2</b>
1	-0.30	-0.40	-1.500 00	-2.000 00	-0.05	0.21	-0.357 14	1.521 74
2	1.50	-0.20	6.726 46	-0.869 57	-0.02	0.19	-0.153 85	1.461 54
3	-0.90	-0.40	-4.285 71	-2.000 00	0.23	0.01	1.691 18	0.071 43
4	0.10	0.30	0.416 67	1.293 10	0.15	0.04	1.181 10	0.307 69
5	0.70	0.10	3.626 94	0.526 32	0.25	0.12	1.838 24	0.857 14
6	-0.40	0.80	-1.709 40	3.636 36	0.13	0.18	1.000 00	1.384 62
7	0.50	-0.80	2.083 33	-3.333 33	0.37	0.08	2.983 87	0.615 38
8	0.70	0.20	2.800 00	0.800 00	0.22	0.19	1.774 19	1.520 00
9	-1.00	-0.30	-5.000 00	-1.578 95	0.14	0.12	1.000 00	0.851 06
10	-0.60	-0.10	-2.857 14	-0.495 05	0.25	0.23	1.851 85	1.691 18
11	0.10	-1.00	0.500 00	-4.761 90	0.23	0.19	1.691 18	1.386 86
12	-1.00	-0.90	-4.000 00	-3.750 00	-0.13	0.09	-1.000 00	0.692 31
13	0.50	0.20	2.500 00	1.000 00	0.17	0.18	1.259 26	1.323 53
14	0.10	-0.70	0.454 55	-3.181 82	0.30	0.32	2.307 69	2.442 75
15	-1.00	-0.80	-4.545 45	-4.000 00	0.36	0.11	2.748 09	0.785 71
16	-1.00	-0.30	-4.166 67	-1.304 35	0.13	0.12	1.000 00	0.916 03
17	-0.40	-0.70	-1.904 76	-3.333 33	0.17	0.26	1.259 26	1.925 93
18	0.40	-0.50	1.666 67	-2.083 33	0.29	0.04	2.320 00	0.307 69

Table 13: Accuracy relative error of the soft wheat data measured by the proposed model and dip sensor during storage in the open air area

Time (Days)	Temperature Absolute Error	Temperature Absolute Error	Temperature Relative Error	Temperature Relative Error	Moisture Content Absolute Error	Moisture Content Absolute Error	Moisture Content Relative Error	Moisture Content Relative Error
	Layer 1	Layer 2	(%) Layer 1	(%) Layer 2	Layer 1	Layer 2	(%) Layer 1	(%) Layer 2
1	-0.20	-0.40	-0.909 09	-1.818 18	0.50	0.35	4.166 67	2.868 85
2	1.00	-1.10	4.347 83	-4.564 32	-0.45	-0.06	-3.629 03	-0.487 80
3	1.20	0.40	6.000 00	2.040 82	0.42	0.26	3.442 62	2.080 00
4	0.70	-1.00	3.333 33	-4.761 90	0.12	0.23	0.967 74	1.840 00
5	0.00	-1.00	0.000 00	-5.000 00	0.44	0.25	3.577 24	1.968 50
6	-0.10	0.10	-0.398 41	0.434 78	0.33	0.21	2.869 57	1.750 00
7	-0.30	-0.50	-1.363 64	-2.463 05	0.22	0.21	1.788 62	1.666 67
8	-0.40	0.80	-1.600 00	3.478 26	0.39	0.14	3.391 30	1.166 67
9	-0.20	-0.80	-0.769 23	-3.100 78	0.12	0.26	1.034 48	2.241 38
10	-0.30	-0.40	-1.363 64	-1.904 76	0.33	0.58	2.704 92	4.793 39
11	0.40	-0.50	1.600 00	-1.960 78	0.49	0.56	4.336 28	4.955 75
12	0.70	1.00	2.916 67	5.000 00	0.29	0.33	2.500 00	2.682 93
13	0.80	-0.80	3.809 52	-3.809 52	0.40	0.12	3.305 79	0.952 38
14	0.20	-0.80	0.869 57	-3.478 26	-0.09	0.45	-0.731 71	3.750 00
15	0.50	-1.30	2.325 58	-5.829 60	0.37	0.03	3.057 85	0.238 10
16	-1.00	0.80	-4.166 67	3.703 70	0.24	0.11	2.000 00	0.894 31
17	-1.40	-1.00	-6.666 67	-5.000 00	0.21	-0.05	1.666 67	-0.384 62
18	-0.70	-0.50	-2.916 67	-2.173 91	0.21	0.00	1.750 00	0.000 00

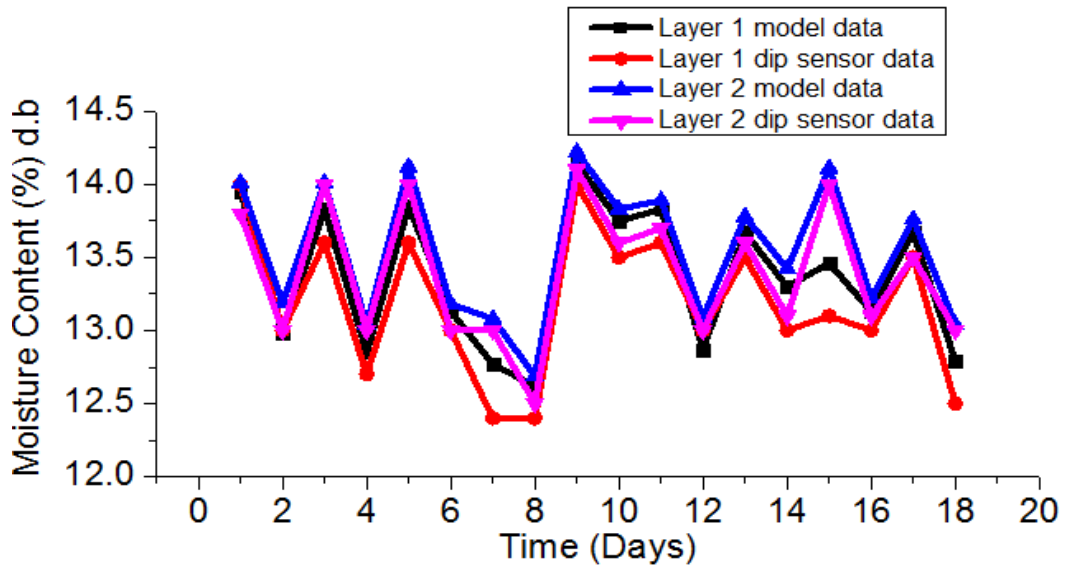

Figure 62: Daily variation of hard wheat storage moisture content by the model and probes in the open air environment

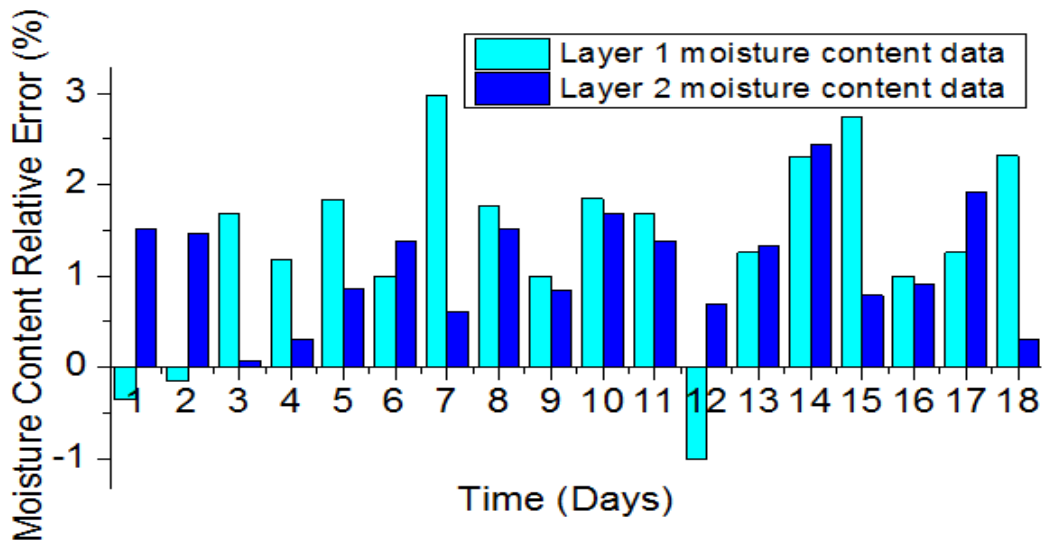

Figure 63: Model relative error in capturing moisture content data from the hard wheat storage

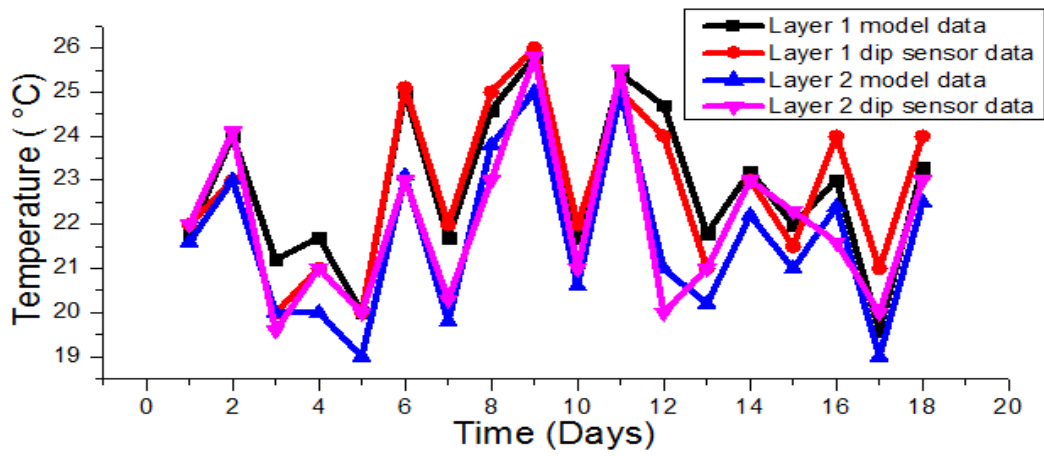

Figure 64: Daily variation of soft wheat storage temperature by the model and probes in the open air environment

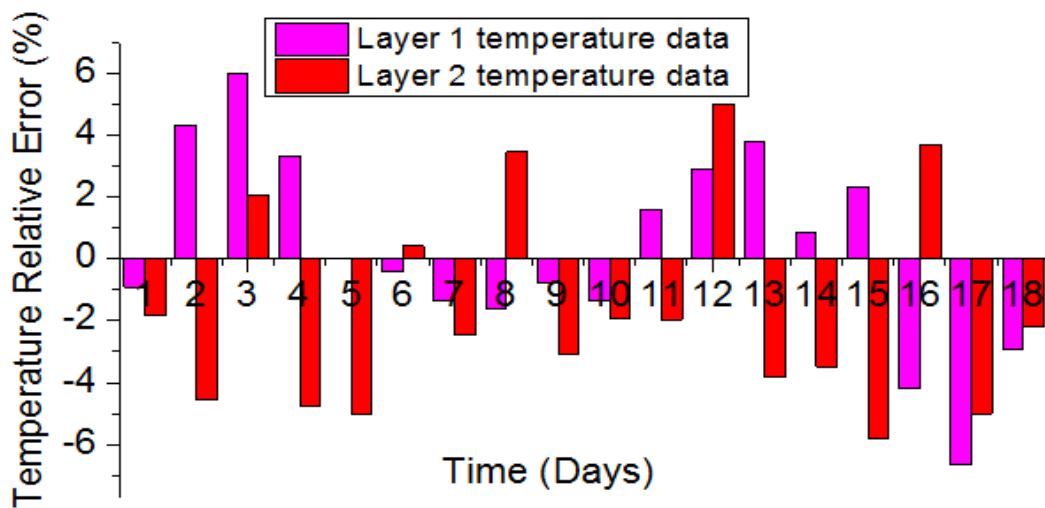

Figure 65: Model relative error in capturing temperature data from the soft wheat storage

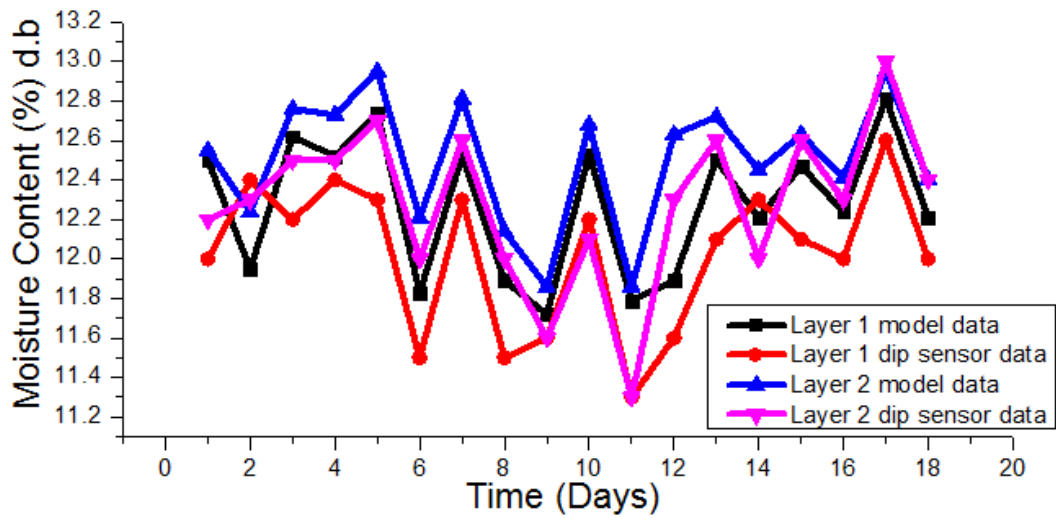

Figure 66: Model relative error in capturing moisture content data from the soft wheat storage

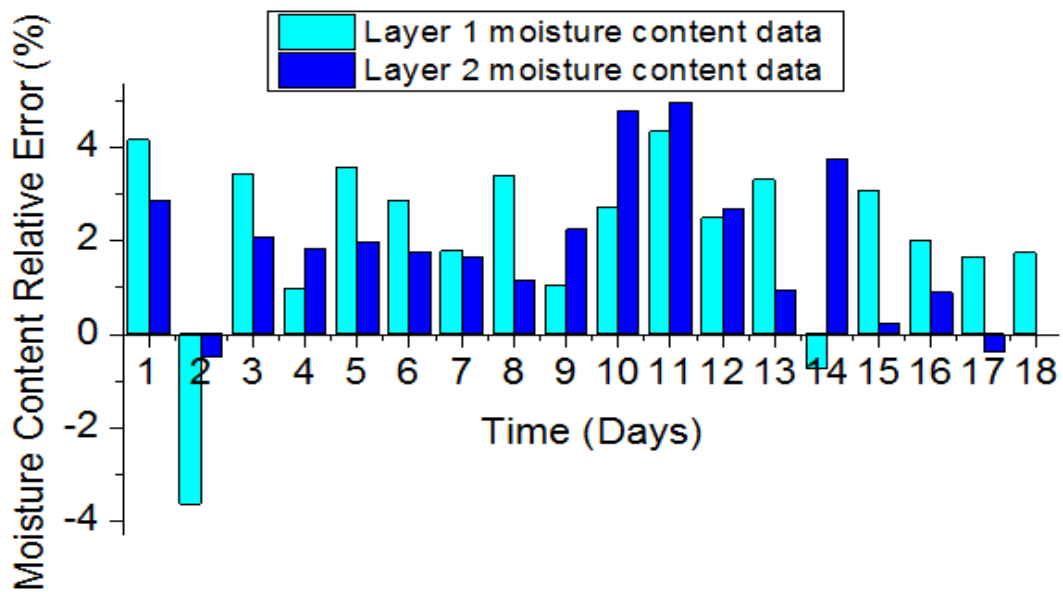

Figure 67: Model relative error in capturing moisture content data from the soft wheat storage

### 6.3.3 Model Precision

A series of experiments was launched using the proposed model in real time against the data predicted. The results showed that the prediction performance was reasonable. Results from

Fig. 68 to 71 demonstrate the prediction of wheat storage condition for 180 days. The dry state dominated the other states. This means that the storage might stay safe for a long time as was marked by FAO (2011) and Kearney (2006 ).

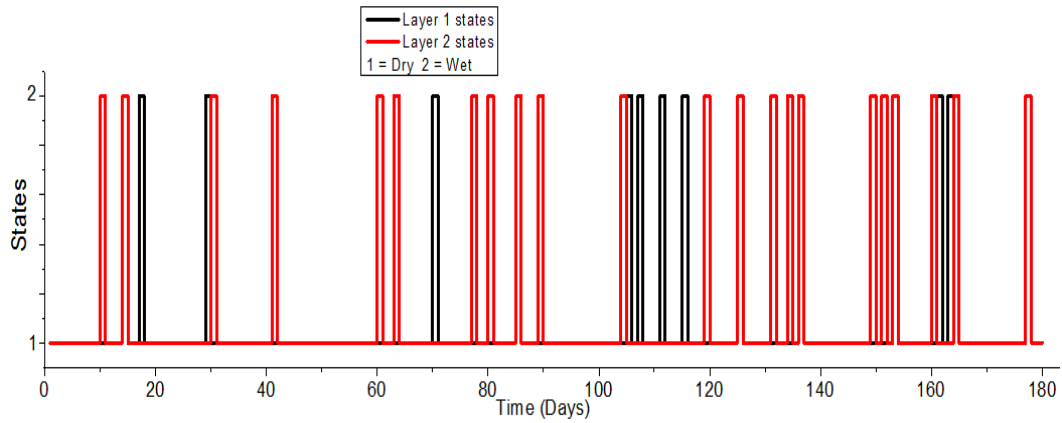

Figure 68: Prediction of hard wheat condition during storage in the greenhouse for 180 days

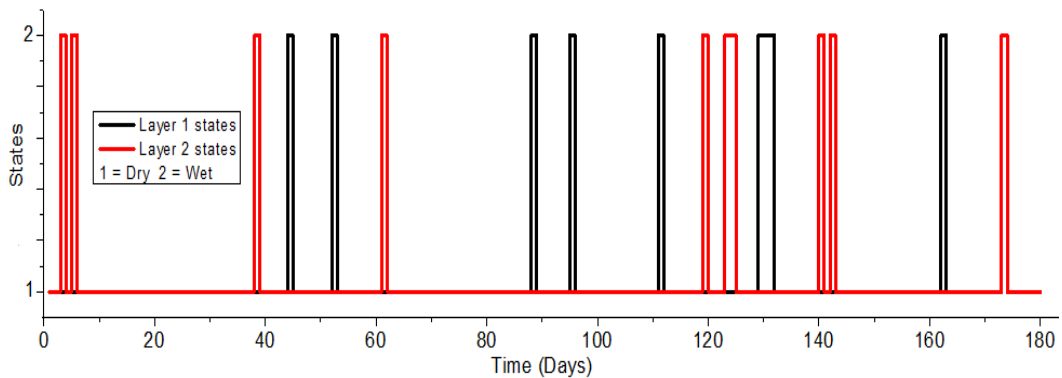

Figure 69: Prediction of soft wheat condition during storage in the greenhouse for 180 days

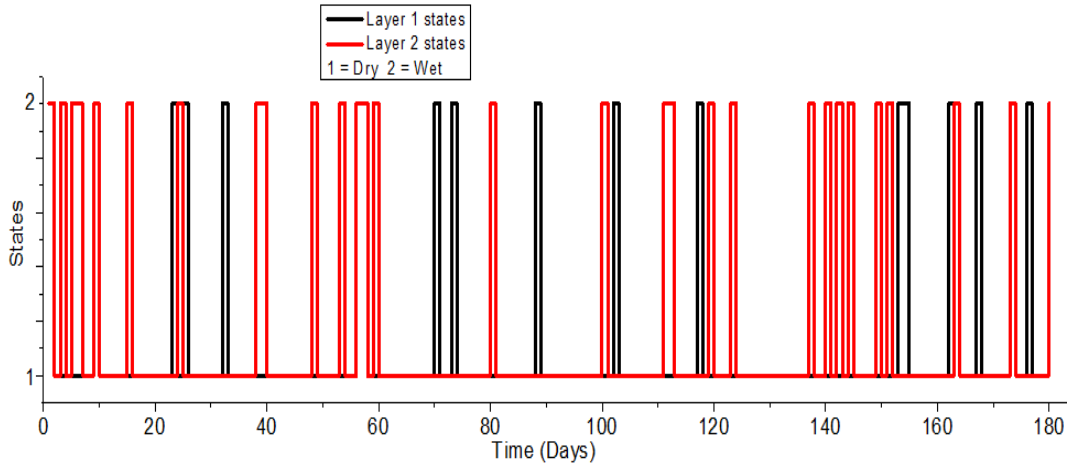

Figure 70: Prediction of hard wheat condition during storage in the open air area for 180 days

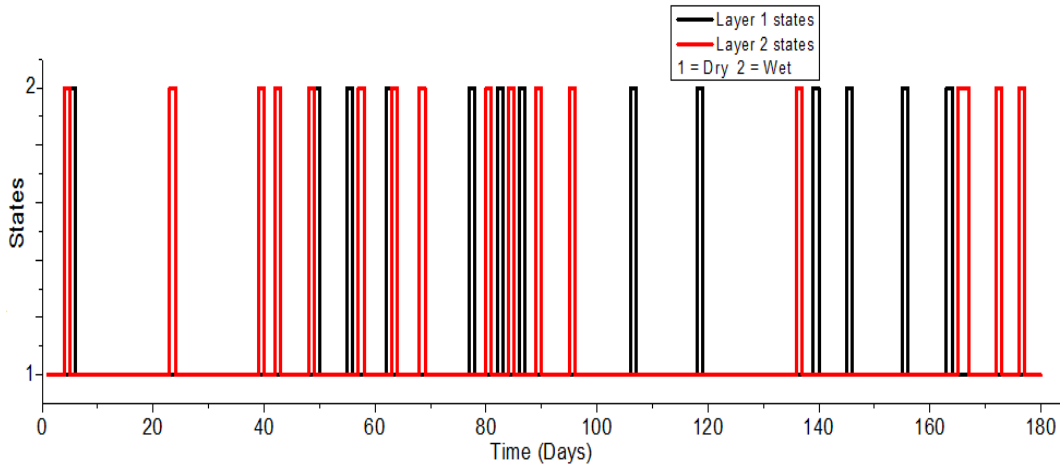

Figure 71: Prediction of soft wheat condition during storage in the open air area for 180 days

As demonstrated from Fig. 72 to 79, the model seems to be a promising method for prediction on wheat grain storage condition changes. The evaluation of the method was done by performing the precision using equation (50). The measurements by the model against the ones taken by the dip sensors were assumed as the true measurements but the forecasted data are as the predicted ones.

In predicting the data during hard wheat grain storage in the greenhouse for 25 days, the model showed the precision of 92 and 84% in layer 1 and 2 respectively as extracted from Fig. 72 and 73. It also showed the precision of 100 and 92% for 25 days in both layer 1 and 2, respectively during soft wheat grain storage also in the greenhouse from Fig. 74 and 75. It



also predicted the hard and soft wheat storage in the open air area with precision of 96% for both layers as indicated from Fig. 76 to 79, respectively. Generally, the model has shown the best performance, which makes it a promising model in forecasting the grain crops' storage condition. However, more days for real measurements are needed to compare with the predicted data.

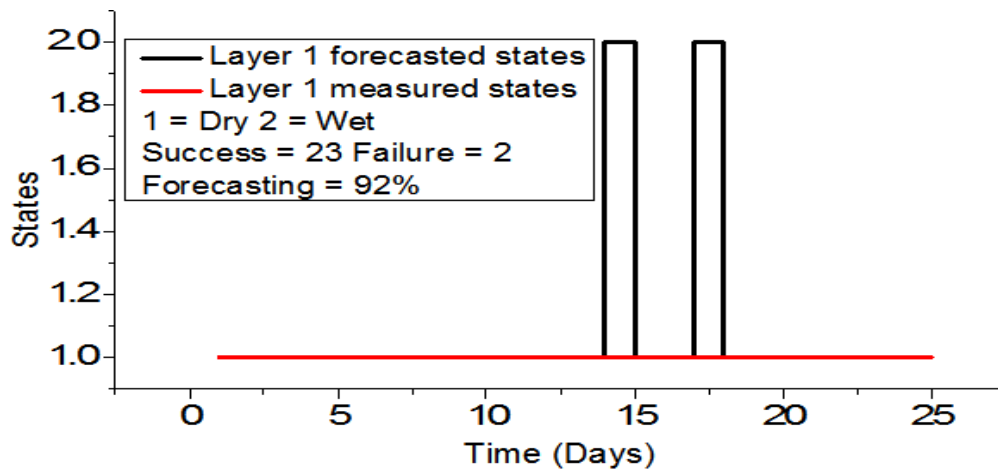

Figure 72: Measured against forecasted states during storage of hard wheat grains in the greenhouse in layer 1 for 25 days

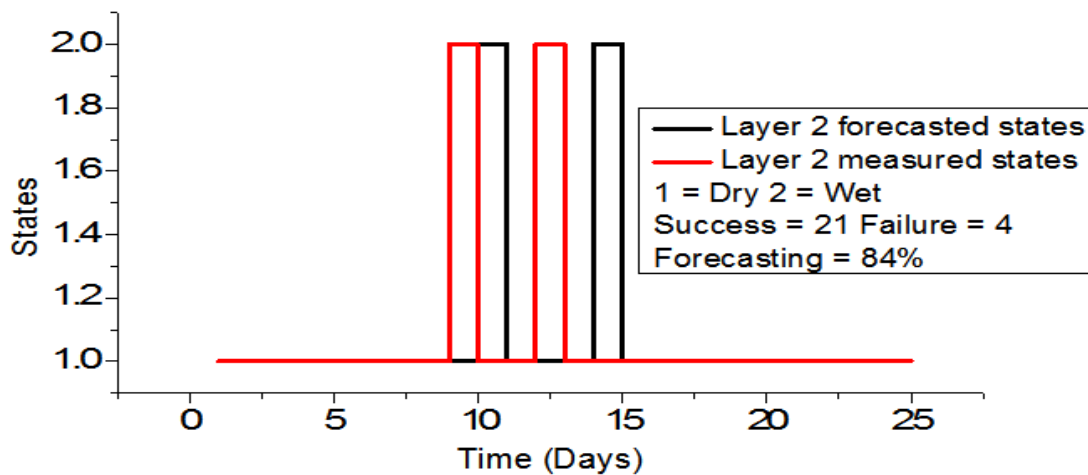

Figure 73: Measured against forecasted states during storage of hard wheat grains in the greenhouse in layer 2 for 25 days

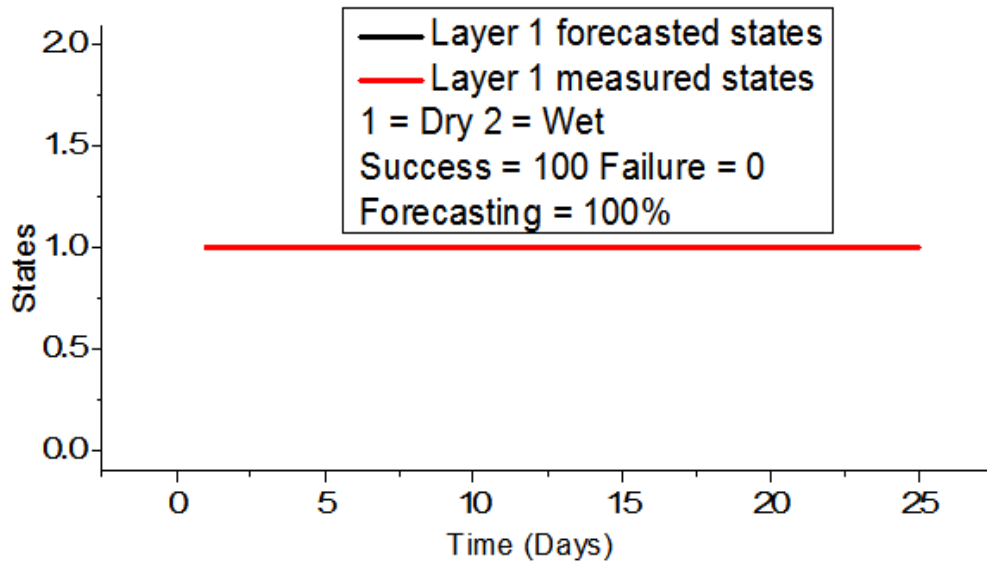

Figure 74: Measured against forecasted states during storage of soft wheat grains in the greenhouse in layer 1 for 25 days

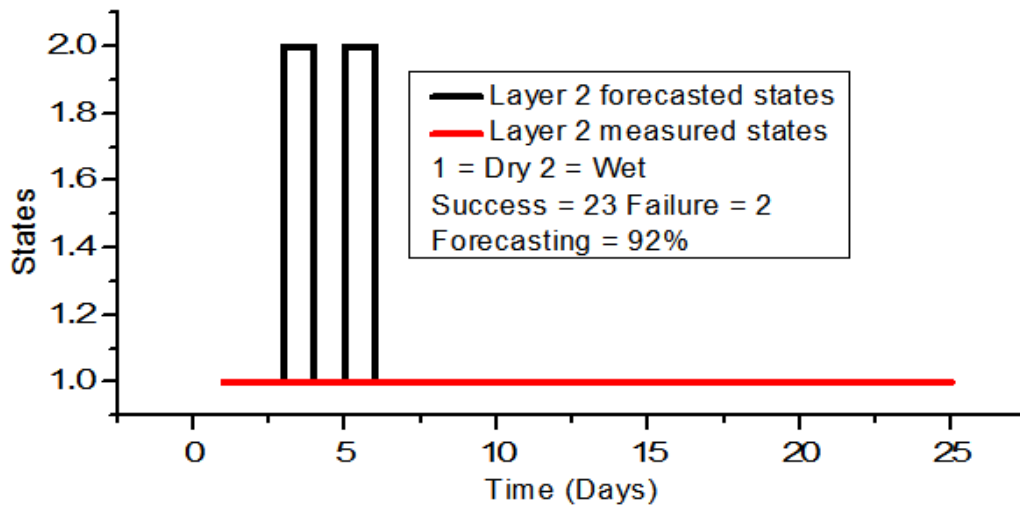

Figure 75: Measured against forecasted states during storage of soft wheat grains in the green house in layer 2 for 25 days

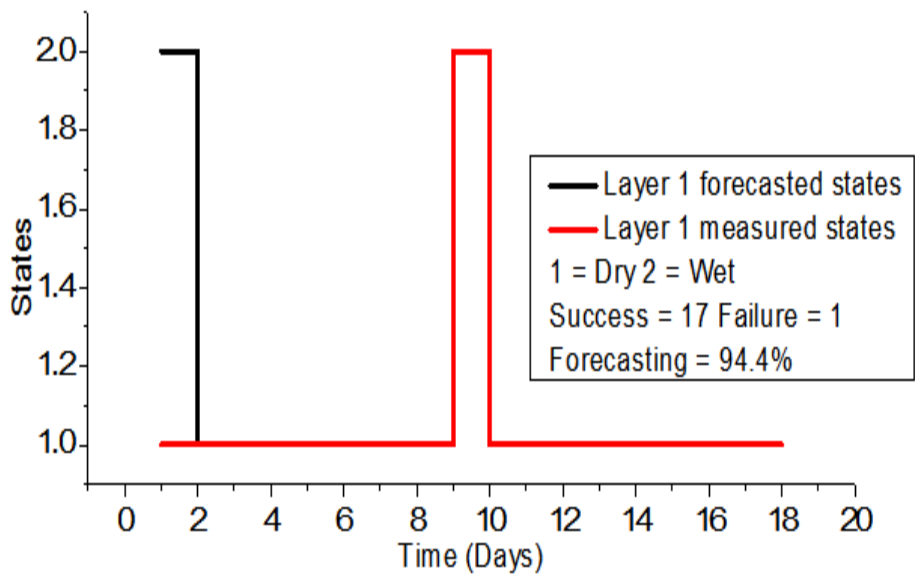

Figure 76: Measured against forecasted states during storage of hard wheat grains in the open area in layer 1 for 18 days

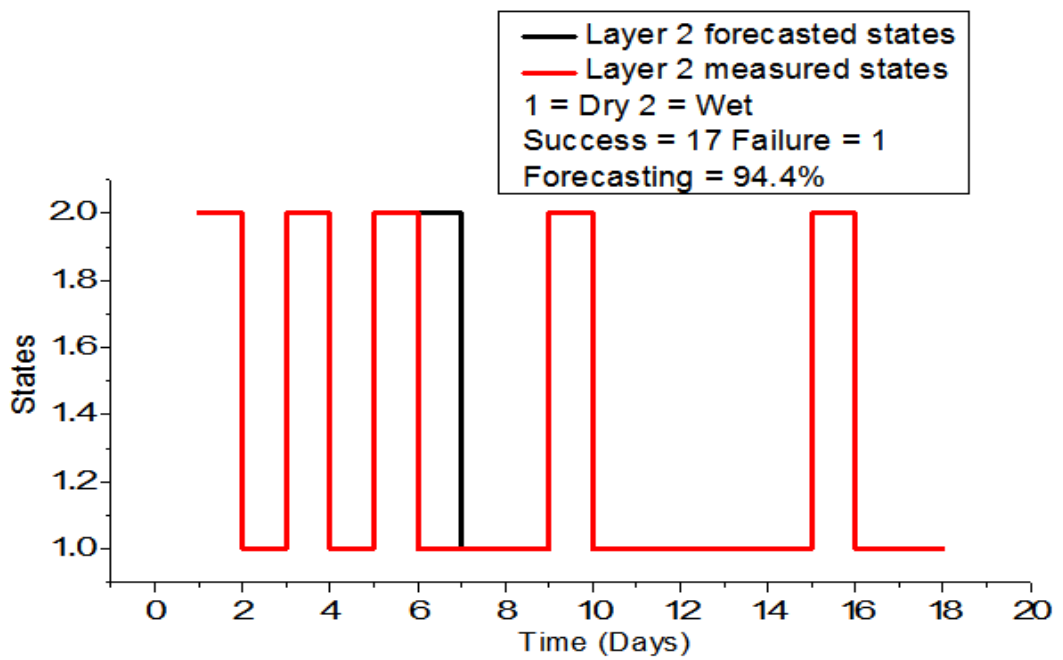

Figure 77: Measured against forecasted states during storage of hard wheat grains in the open area in layer 2 for 18 days

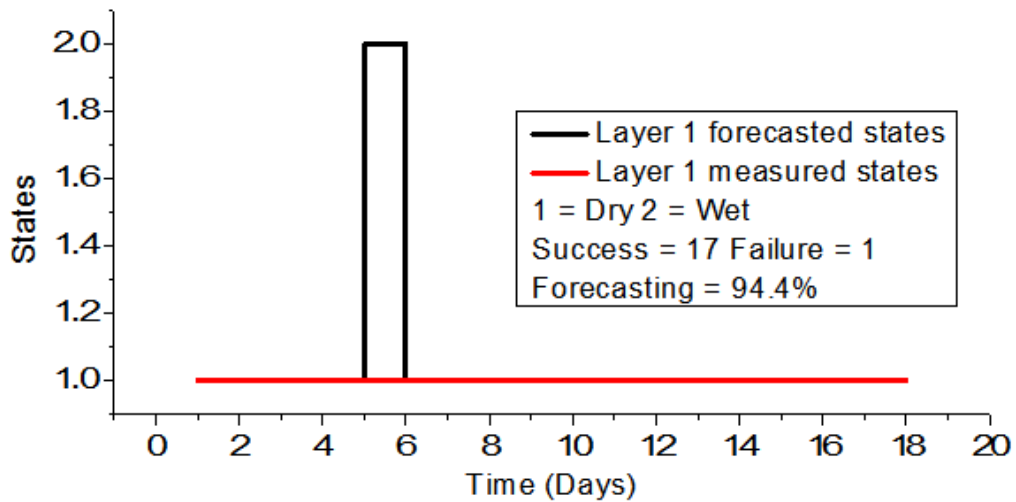

Figure 78: Measured against forecasted states during storage of soft wheat grains in the open area in layer 1 for 18 days

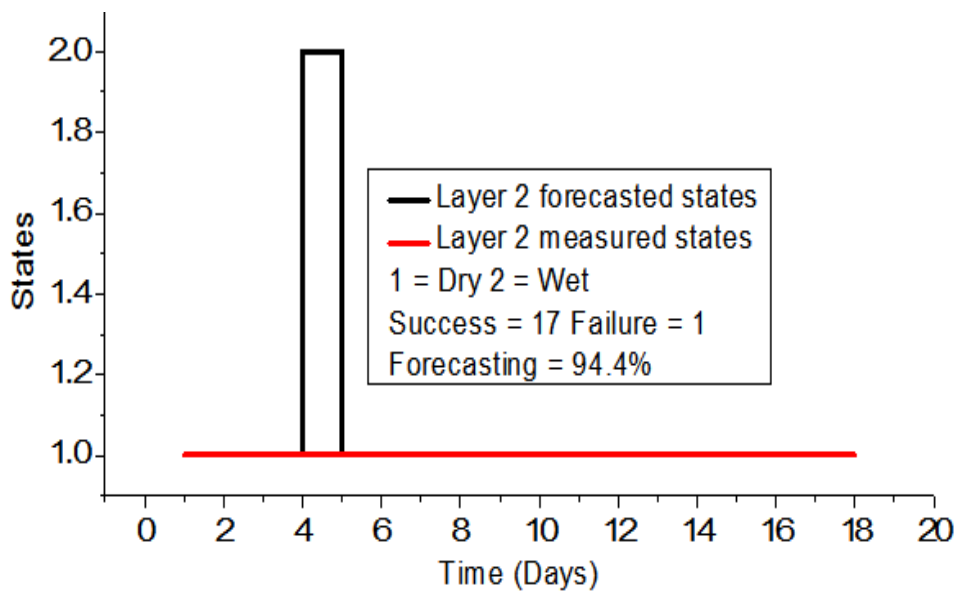

Figure 79: Measured against forecasted states during storage of soft wheat grains in the open area in layer 2 for 18 days

### 6.4 Conclusion

In this work, we presented the performance results of a wheat grain storage monitoring technology for environmental parameters using ZigBee wireless technology. The testing and exploitation of the model were a three leg processes. In the first leg, the method was performed to evaluate its robustness. During the measurement period, temperature and moisture were investigated to check the robustness of the model. It was observed that once they varied, the model was capable of responding to the changes in both dielectric constants

of wheat and refractivity. In the second leg, the model was performed to check the accuracy when monitoring the storage condition. To confirm the accuracy of the model, the comparison was done between the model and the commercial dip sensors. It was observed that into all layers of the storage in different environments, the model operated accurately. The final leg was due to the precision of the model in forecasting the storage condition of wheat grains. It was observed that the model performed precisely over 90% except in layer 2 during hard wheat storage in the greenhouse a prediction of 25 days where the precision was 84%. However, the results showed that it is possible to monitor these environmental parameters through wireless communication technology. The results attained justify that the model works as envisaged, and functions robustly, accurately and precisely. The proposed method is able to sustain itself based on the non-invasive sensors. However, it is recommended to take more time in real time measurements to assure the model long operation.

## CHAPTER SEVEN

### GENERAL DISCUSSION, CONCLUSION AND RECOMMENDATIONS

#### 7.1 General Discussion

In this chapter, the study discusses and summarizes the research contributions with regard to the monitoring of grain crop storage through wireless communication technology. It also presents the recommendations to the challenges incurred during the research process in order to refine the approach used. The work is sequentially ordered by three interrelated research questions answering the pertinent specific objectives of the study. Their respective findings are discussed and presented below:

*What are the factors that influence the design of the model for monitoring the grain crops in the storage facilities?*

Analysis on the model for monitoring the grain crops in the storage facility was carried out to identify the suitable factors that influence its design. It was revealed that electromagnetic radiation is the best technique in cereal grain processing. It was further found that electrical properties of grains are affected by the frequency, moisture content; temperature, bulk density and storage time. The frequency was identified as the key element that affects the dielectric properties of the material to influence polarization in electromagnetic radiation. The moisture content was spotted as the next element that influences the change of dielectric properties of the grains. The rise of total polarization of the grains is influenced by the rise of moisture content. But also, it was found that the temperature affects dielectric properties, once it varies. Moreover, the density was also found to have the effect on the dielectric properties with the condition depending on amount of mass interacting with the electromagnetic fields. But, the size of particles in the mixture when gets much smaller than the wavelength of the waves, the effective permittivity depends only on the shape of the particles and is independent of their size (Guo *et al.*, 2013; Nelson and Trabelsi, 2012). Furthermore, storage time changes the dielectric properties of grains. But, it was found to be moisture dependent. The grains' dielectric properties can decrease with increase of storage time due to the loose of moisture content (Ponomaryova, 2011). Further investigation was conducted on electromagnetic frequencies by considering microwave and radio frequencies that are mostly applied in sensing environmental parameters of the grains. It was found that radio frequency has a good maximum penetration depth than microwave frequency. However, RF was

identified that it needs to be applied to the material with a simple and regular shape. The details of these findings are reported in chapter two.

For appropriate storage monitoring, the analysis on stochastic modeling techniques was conducted. Stochastic technologies such as the Artificial Neural Network (ANN), Hidden Markov (HMM), and Markov Chain (MC) have received a significant attention in agricultural application for event prediction. It was found that Markov chain is better for sequential states prediction but not for both hidden and observed predictions. Moreover, ANN was identified as the superior techniques capable in complex computations and convergence. However, it has the black box nature that causes greater computation burden on the hardware infrastructure for the analysis. Furthermore, it was found that HMM is capable of predicting both hidden and observed states. It can also emit one symbol using more than one states and a state can emit more than one symbol. The details of these results are reported in chapter three.

*What are the new factors to be incorporated in designing the effective model for determining and forecasting the wheat storage condition?*

The model for determining and forecasting the wheat grain condition was proposed. It contains two sub-models which are closely related. The first sub-model is the non-invasive method capable of examining the condition of grain bulk from the storage facility basing on electromagnetic properties. It was designed of dielectric constants and radio refractivity factors with respect to bulk density, relative humidity, moisture content and temperature. The study considered wheat grain varieties (hard, durum and soft wheat) as the prime cereal grains for the storage in the design. The method was then analyzed in Matlab at the frequency range of 1-15 kHz. It was found that the proposed method was capable of determining moisture and temperature successfully. All varieties of wheat responded successfully with their dielectric properties in relation to the refractivity with the variation of temperature and moisture contents. The relative humidity, moisture content and temperature also showed successfully the isothermal characteristics of Type II food products where wheat belongs. The detailed results are presented in chapter four. However, the method is limited only to the three types of wheat, the frequency range of 1 to 15 kHz and the dielectric constant range of 2 to 7 of wheat. Second sub-model that was proposed in the model is the three state grain storage condition technique based on Hidden Markov model capable of forecasting storage

condition. It bases on the three visual occurrences of the grains due to variation of temperature and moisture in the storage. It was designed and then analyzed in MATLAB to ensure its prediction in different periods and its maximum likelihood. It was found that the model was capable of predicting the hidden and observed conditions with time. This implied that the transition probability from one hidden state to another could match the storage future state with respect to given observation to affect the grain quality. However, the method is only limited to prediction and displaying the results but not for controlling the situation reported. The detailed result findings reported in chapter five.

*Can the proposed technology accurately detect and predict storage weather parameters and condition through wireless technology?*

In order to evaluate the performance of the proposed in real time, the prototype was developed and tested using MATLAB and java programming tools; Looyenga dielectric empirical model, accuracy and standard precision equations were employed in evaluation process. Electrical properties of grains due to the variation of storage weather, relative errors, success and failure of the storage condition prediction were used as key metric assessment for the performance of the model. It was identified that the model was robust to the changes due to the variation of storage weather. There was the effect on the dielectric constant and refractivity due to the changes in relative humidity or moisture content and temperature in the storage. It was also found that the accuracy of the model with respect to commercial probes was excellent due to the less relative errors observed in all layers of the storage for both types of wheat (hard and soft wheat) in the greenhouse and open air environments. Moreover, the model precision on the failure and success of grain condition prediction was also excellent as the precision errors were observed to be less. Furthermore, the data transmission through ZigBee network from the storage to the monitoring computer had no any problem as they appeared to match the progress with the ones recorded by commercial devices. However, the experiments were carried out for short durations of 25 and 18 days compared to 180 days taken for prediction.

The study has portrayed that grain storages of different types can be implemented using Non-invasive method for determining and forecasting grain storage condition. Besides, the dielectric constant difference (initial and current final dielectric constants) of the various cereal grains can be employed exploiting refractivity. This study has employed refractivity



based on wheat dielectric constant for determining wheat grain storage weather parameters, and the states of the grain storage based the captured data (temperature and moisture content) for predicting the future condition of the storage. This is the contribution of the study to the existing grain storage monitoring technologies, since many of them employ different storage techniques to suit their needs (Makalle, 2012; Tefera and Abass, 2012; Wang *et al.*, 2014; Nelson and Trabelsi, 2008; Nath and Ramanathan, 2017; Dong *et al.*, 2014). From this stance the proposed model, as a new grain crop monitoring method is an achievement. Despite extensive research on grain crop storage monitoring, there is still no method bearable for monitoring the storage of large amount of grains using radio refractive quantity technology (refractivity). The environmental parameter determination using dielectric constant from the grain storage is hard to ascertain due to the shape, bulk density and kernel size of different types of cereal grains (Jha, *et al.* 2011; Ponomaryova, 2011). Applying only dielectric constant (Wang and Wang, 2012) without considering further interaction, limits its capability in determining accurately the weather condition in a grain storage with large amount of grains. Though refractivity seems to be a basic requirement of air relative humidity measurement, the lack of its subsistence insinuates the limitations of previous technologies. Possibly it is forthright that firm realization of these methods are not efficient, but this study has argued that without the suitable application for further signal interaction, these systems cannot anticipate to support the monitoring of grain storage condition for the grain quality. Because of the advantages offered by the proposed model using refractivity and Hidden Markov technique, commercial development of non-invasive technology for determining the temperature and moisture can reliably monitor the grain storage condition.

## **7.2 General conclusion**

The main objective of this study was to design the method for monitoring the grain crops in the storage facility through wireless technology. Consequently, the study showed that incorporation of both dielectric constant and radio refractive quantity into grain condition detection technique leads to a better modeling technology. The study also presented an effective forecasting technique based on Hidden Markov model capable of predicting the future wheat grain storage conditions.

The literature review on the existing technologies showed that there is still an importance for further study on the techniques using electromagnetic application for detecting temperature

and moisture content from the storage of large amount of grains. Moreover, it was identified that the volume, size and shape of grains are limiting factors to detection of environmental parameters from the bulk of grains. The analysis also showed that the forecasting techniques such as Artificial Neural Networks, Hidden Markov Model and Markov Chain are good for management and planning in various applications, thus they can also be applied in food security. For that reason, this study presented the non-invasive model wireless solution for capturing the weather parameters from the grain crop storage with forecasting ability to ensure the future status of the storage. The proposed method was tested and evaluated using MATLAB®, OriginPro and Java tools. The evaluation was carried out to test the robustness, accuracy and precision of the proposed model.

The findings indicated that the proposed model is capable of determining the temperature and moisture content with respect to refractivity and dielectric constant changes from the grain storage of large amount of grains. It also showed that condition variation during the storage in the open air environment was higher than in the green house. Thus, the model confirmed to be robust in realizing grain storage condition changes compared to the existing technologies. Moreover, the serious accuracy relative errors from hard wheat storage were marked between -5 and 6.73% (temperature measurements), -4.76 and 3.74% (moisture content measurements) and from the soft wheat storage were between -6.67 and 6% (temperature measurements), -3.63 and 4.96% (moisture content measurements) which were not too substantial to alter the monitoring process. The evaluation of model precision was demonstrated over 90% most of the time. For these successes, the overall performance means the model is efficient to monitor the grain storage. This could lay out the best grounds of the measures to avoid toxic mycotoxins and infestation from affecting the quality of grains, which are caused by the variation of temperature and moisture in storage. Mycotoxins' isolation from the stored grains means to free both human beings and animals from cancer and death which may occur due the consumption of contaminated grains. These toxic compounds are produced by fungi and readily inhabit crops. These toxins are produced due to the variation of moisture and temperature in the grain storage. They may cause cancer and death to both animals and human beings once consumed.

It is therefore argued that the implementation of the technology would be important for its applications in real environment to serve the quality of stored grains.

### **7.3 Recommendations**

This study explored the use of electrical properties (refractivity in relation with dielectric properties) and probabilistic approach for monitoring the wheat storage condition. Principally, it dealt only with wheat grains looking at the refractivity interaction with dielectric constant for determining storage temperature and moisture content as well as the application of first order Hidden Markov model in predicting the future storage conditions. For that reason, it could be extended and applied in solving storage problems to a wide range of cereal crops. Moreover, the proposed method should be enhanced by including the organisms and gases that also motivate the condition changes in the storage facility. This will facilitate in monitoring of the storage condition of wheat grains and provide new mechanism for the other dielectric features which were not included in this model. In addition, further study should be conducted on the correlation between the concentration, structure, composition, constituents and electrical properties of wheat grains to have a solid non-invasive technology for determining the grain storage condition variation. The research work could also be done on controlling of storage condition by taking into account the control of the weather in case of unwanted variation of temperature and moisture content in the grain storage. Thus, the effective anti-storage condition variation gear must be developed in future and targeted at the storage facility. Furthermore, first order Hidden Markov model was used to describe the states of the wheat storage due to the variation of temperature and moisture content occurring into the storage. It performed well in terms of precision and accuracy. However, the study did not consider the technique in predicting the ambient condition in parallel with the storage states. Therefore, more research work is needed to distill the forecasting definition method as well as predicting the future storage temperature and moisture content.

## REFERENCES

- Abdulkadir, S. J., Shamsuddin, S. M. and Sallehuddin, R. (2012). Moisture Prediction in Maize using Three Term Back Propagation Neural Network. *International Journal of Environmental Science and Development*. 3(2): 199.
- Abdullah, N. A. and Quteishat, A. M. (2015). Wheat Seeds Classification using Multi-Layer Perceptron Artificial Neural Network. *International Journal of Electronics and Computer Engineering*. 6(2): 306-309.
- Abhishek, K., Kumar, A., Ranjan, R. and Kumar, S. (Ed.) (2012). A Rainfall Prediction Model using Artificial Neural Network. In: the IEEE Control and System Graduate Research Colloquium (ICSGRC), Shah Alam, Malaysia, 16-17.
- Adam, R. Y. (2016). Stochastic Model for Rainfall Occurrence Using Markov Chain Model in Kurdufan State, Sudan. *American Scientific Research Journal for Engineering, Technology and Sciences (ASRJETS)*. 17(1): 272-286.
- Adeyanju, I., Ojo, O. and Omidiora, E. (2016). Recognition of Typewritten Characters Using Hidden Markov Models. *British Journal of Mathematics and Computer Science*. 12(4): 1-9.
- Agarwal, T. (2015). ZigBee Wireless Technology Architecture and Applications. The Budding Electronic Engineers' Knowledge Space.[<https://www.elprocus.com/what-is-zigbeetechnology-architecture-and-its-applications/>]. Accessed on August 10, 2017
- Agnew, J. (2017). Equilibrium Moisture Content Charts for Grain Storage Management. In P. A. M. Institute (Ed.). Saskatchewan: Pami.[<http://www.pami.ca/>]. Accessed on December 08, 2016.
- Akinci, T. (2015). Short Term Wind Speed Forecasting with ANN in Batman, Turkey. *Elektronika ir Elektrotechnika*. 107(1): 41-45.
- Akosa, J. S. (2015). Predictive Accuracy: A Misleading Performance Measure for Highly Imbalanced Data. *Oklahoma State University*. 942: 1-12.

- Al-Mahasneh, M., Alkoaik, F., Khalil, A., Al-Mahasneh, A., El-Waziry, A., Fulleros, R. and Rababah, T. (2014). A Generic Method for Determining Moisture Sorption Isotherms of Cereal Grains and Legumes using Artificial Neural Networks. *Journal of Food Process Engineering*. **37**(3): 308-316.
- Albornoz, M. A. (2013). Strategies to Overcome Interferences during Biomass Monitoring with Dielectric Spectroscopy. Thesis for the Award of Doctor of Philosophy Degree at Heriot-Watt University Edinburgh, Scotland. pp.1-199.
- Alfaifi, B., Tang, J., Jiao, Y., Wang, S., Rasco, B., Jiao, S. and Sablani, S. (2014). Radio Frequency Disinfestation Treatments for Dried Fruit: Model Development and Validation. *Journal of Food Engineering*. **120**: 268-276.
- Alkadri, D., Rubert, J., Prodi, A., Pisi, A., Mañes, J. and Soler, C. (2014). Natural Co-occurrence of Mycotoxins in Wheat Grains from Italy and Syria. *Food Chemistry*. **157**: 111-118.
- AlKhateeb, J. H., Pauplin, O., Ren, J. and Jiang, J. (2011). Performance of Hidden Markov Model and Dynamic Bayesian Network Classifiers on Handwritten Arabic Word Recognition. *Knowledge-based Systems*. **24**(5): 680-688.
- Alyoubi, B. A. and El Emary, I. M. (2016). The Zigbee Wireless Sensor Network In Medical Applications: A Critical Analysis Study. *Journal of Current Research in Science*. **4**(1): 7.
- ASAE. (2016). Equilibrium Moisture Equation Constants: American Society of Agricultural and Biological Engineers. [[http://www.asabe.org/media/124415/emc\\_eqn\\_cons](http://www.asabe.org/media/124415/emc_eqn_cons)]. Accessed on November 18, 2018.
- Asefi, M., Jeffrey, I., LoVetri, J., Gilmore, C., Card, P. and Paliwal, J. (2015). Grain Bin Monitoring via Electromagnetic Imaging. *Computers and Electronics in Agriculture*. **119**: 133-141.
- Awika, J. M., Piironen, V. and Bean, S. (2011). Major Cereal Grains Production and use around the World Advances in Cereal Science: Implications to Food Processing and Health Promotion. In: Advances Cereal Science: Implications to Food Processing and Health Promotion: Texas University. pp. 1-13.

- Awuah, G. B., Ramaswamy, H. S. and Tang, J. (2014). Radio-Frequency Heating in Food Processing: Principles and Applications: CRC Press.405pp.
- Ayer, T., Chhatwal, J., Alagoz, O., Kahn Jr, C. E., Woods, R. W. and Burnside, E. S. (2010). Comparison of Logistic Regression and Artificial Neural Network Models in Breast Cancer Risk Estimation 1. *Radiographics*. **30**(1): 13-22.
- Bankole, S. and Adebajo, A. (2004). Mycotoxins in Food in West Africa: Current Situation and Possibilities of Controlling it. *African Journal of Biotechnology*. **2**(9): 254-263.
- Bartolucci, F. and Lupporelli, M. (2016). Pairwise Likelihood Inference for Nested Hidden Markov Chain Models for Multilevel Longitudinal Data. *Journal of the American Statistical Association*. **111**(513): 216-228.
- Bartosik, R. E., Cardoso, L. and Rodríguez, J. (Ed.) (2008). Early Detection of Spoiled Grain Stored in Hermetic Plastic Bags (Silo-bags) using CO<sub>2</sub> Monitoring. In: the Proceeding of 8th International Conference on Controlled Atmosphere and Fumigation in Stored Products, Chengdu, China, 2008.
- Bassi, P., Sacco, E., De Marco, V., Aragona, M. and Volpe, A. (2007). Prognostic Accuracy of an Artificial Neural Network in Patients Undergoing Radical Cystectomy for Bladder cancer: A Comparison with Logistic Lanalysis. *BJU international*. **99**(5): 1007-1012.
- Bhardwaj, S., Sharma, V., Srivastava, S., Sastry, O., Bandyopadhyay, B., Chandel, S. and Gupta, J. (2013). Estimation of Solar Radiation using a Combination of Hidden Markov Model and Generalized Fuzzy Model. *Solar Energy*. **93**: 43-54.
- Bhargava, N., Jain, R., Joshi, I. and Sharma, K. (2014). Investigation of Dielectric Properties of Some Varieties of Wheat and their Correlation with Food Nutrients. **3**(2): 392-400.
- Bietti, A., Bach, F. and Cont, A. (Ed.) (2015). An online EM Algorithm in Hidden (Semi-) Markov Models for Audio Segmentation and Clustering. In: the IEEE International Conference on Acoustics, Speech and Signal Processing (ICASSP), Brisbane, Australia, April, 2015.

- Binder, E. M. (2007). Managing the Risk of Mycotoxins in Modern Feed Production. *Animal Feed Science and Technology*. **133**(1): 149-166.
- Blunsom, P. 2004. Hidden Markov Models. Utah State University. [<http://www.cs.usu.edu>]. Accessed on October 10, 2016.
- Bolch, G., Greiner, S., De Meer, H. and Trivedi, K. S. (2006). Queueing Networks and Markov Chains: Modeling and Performance Evaluation with Computer Science Applications. John Wiley and Sons Inc. New Jersey. 896pp.
- Bracken, C., Rajagopalan, B. and Zagona, E. (2014). A Hidden Markov Model Combined with Climate Indices for Multidecadal Streamflow Simulation. *Water Resources Research*. **50**(10): 7836-7846.
- Bryden, W. L. (2012). Mycotoxin Contamination of the Feed Supply Chain: Implications for Animal Productivity and Feed Security. *Animal Feed Science and Technology*. **173**(1): 134-158.
- Canon, L. C. and Jeannot, E. (Ed.) (2007). A Comparison of Robustness Metrics for Scheduling Dags on Heterogeneous Systems. In: the Cluster Computing, 2007 IEEE International Conference, Austin, United States, September, 2007.
- Castrejón, A. V., González, M. V. R. and Ponomaryova, I. (2015). Study of Dielectric Parameters and the Internal Electric Field Prediction in an Individual Wheat Grain Particle. In: the Electrical Engineering, Computing Science and Automatic Control (CCE), 2015 12th International Conference, Mexico city, Mexico, 28 to 30 October, 2015.
- Chakraborty, S. and Newton, A. C. (2011). Climate Change, Plant Diseases and Food Security: an Overview. *Plant Pathology*. **60**(1): 2-14.
- Changchun, B., Zhihong, L., Lishan, Z., Guofang, L., Cuifen, L., Yanping, L. and Zhipeng, L. (2009). Design of Monitoring System for Grain Depot Based on ZigBee technology. *Transactions of the Chinese Society of Agricultural Engineering*. **25**(9): 197-201.

- Chattha, S., Hasfalina, C., Lee, T. Mirani, B. and Mahadi, M. (2015). A study on the Quality of Wheat Grain Stored in Straw-clay Bin. *Journal of Biodiversity and Environmental Science*. **6**(1): 428-437.
- Chayjan, R. and Esna-Ashari, M. (2010). Modeling of Heat and Entropy Sorption of Maize (cv. Sc704): Neural Network Method. *Research in. Agricultural. Engineering*. **56**(2): 69-76.
- Chen, H., Zhang, J., Xu, Y., Chen, B. and Zhang, K. (2012). Performance Comparison of Artificial Neural Network and Logistic Regression Model for Differentiating Lung Nodules on CT scans. *Expert Systems with Applications*. **39**(13): 11503-11509.
- Chen, Z. and Qiu, R. C. (2010). Prediction of Channel State for Cognitive Radio using Higher-order Hidden Markov Model. In: the Proceedings of IEEE SoutheastCon 2010 (SoutheastCon), Concord, USA, 18 to 21 March, 2010.
- Chenchen, G. W. Z. Z. Y. (2013). Moisture Meter for Coarse Cereals Based on Dielectric Properties [J]. *Transactions of the Chinese Society for Agricultural Machinery*. **5**: 032.
- Ching, W. K., Ng, M. K. and Fung, E. S. (2008). Higher-order Multivariate Markov chains and their Applications. *Linear Algebra and its Applications*. **428**(2): 492-507.
- Choi, Y. and Cardie, C. (2007). Structured Local Training and Biased Potential Functions for Conditional Random Fields with Application to Coreference Resolution. In: the HLT-NAACL, New York, USA, 22 to 27 April, 2007.
- Chulze, S. (2010). Strategies to Reduce Mycotoxin Levels in Maize during Storage: A Review. *Journal of Food Additives and Contaminants*. **27**(5): 651-657.
- Cioffi, F., Devineni, N., Monti, A. and Lall, U. (2013). Stochastic Downscaling of Daily Rainfall: Analysis of Future Hydroclimatic Changes and their Impact on the Pontinia Plain using Nonhomogeneous Hidden Markov Model and Dynamic Hierarchical Bayesian Network Model. In: the EGU General Assembly Conference, Vienna, Austria, 7 to 12 April, 2013.



- Coviello, E., Chan, A. B. and Lanckriet, G. R. (2014). Clustering Hidden Markov Models with Variational HEM. *The Journal of Machine Learning Research*. **15**(1): 697-747.
- Das, A. and Hasegawa-Johnson, M. (2015). Cross-lingual Transfer Learning during Supervised Training in Low Resource Scenarios. In: the Sixteenth Annual Conference of the International Speech Communication Association, Dresden, Germany, 6 to 10 Sptember, 2015.
- Das, I., Kumar, G. and Shah, N. G. (2013). Microwave Heating as an Alternative Quarantine Method for Disinfestation of Stored Food Grains. *International Journal of Food Science*. **2013**: 1-13
- Dastidar, A. G., Ghosh, D., Dasgupta, S. and De, U. (2010). Higher Order Markov Chain Models for Monsoon rainfall over West Bengal, India. *Indian Journal of Radio and Space Physics*. **39**(1): 39-44.
- Datta, A. K. (2001). *Handbook of Microwave Technology for Food Application*. CRC Press.536pp.
- Degirmenci, A. (2014). Introduction to Hidden Markov Models.Havard Edu.<http://www.havard.edu/files/adeqirmenci> . Accessed on October 25, 2016
- Deni, S. M., Jemain, A. A. and Ibrahim, K. (2009). Fitting Optimum Order of Markov Chain Models for Daily Rainfall Occurrences in Peninsular Malaysia. *Theoretical and Applied Climatology*. **97**(1-2): 109-121.
- Deshpande, N. and Shaligram, A. (2012a). Study of Mobile Node Based Coverage Recovery Process for WSN Deployed in Large Food Grain Warehouse. *International Journal of Advances in Engineering and Technology*. **5**(1):422-429.
- Deshpande, N. and Shaligram, A. (2012b). Study of Mobile Node Based Coverage Recovery Process for WSN Deployed in Large Food Grain Warehouse. *International Journal of Advances in Engineering and Technology*. **5**(1):422-429.
- Doitpoms. (2015). Effect of Temperature on the Dielectric Constant. Univesity of Cambridge. <http://doitpoms.ac.uk/tlplb/dielectrics/temperature.php>. Accessed on August 22, 2017.

- Dong, J., Li, H., Liu, Y., Guo, Y. and Tang, G. (2014). Design of a Wireless Monitoring Network for Granary Temperature and Humidity Based on Zigbee. *International Journal of u-and e-Service, Science and Technology*. 7(2): 77-82.
- Dong, M. and He, D. (2007). Hidden semi-Markov Model-based Methodology for Multi-sensor Equipment Health Diagnosis and Prognosis. *European Journal of Operational Research*. 178(3): 858-878.
- Duan, J. (2015). An Introduction to Stochastic Dynamics: Cambridge University Press., New York. 291pp.
- Dymarski, P. (Ed.) (2011). Hidden Markov Models, Theory and Applications. InTech Open Access Publisher.326pp.
- Edet, C. O., Ettah, B. and Kamgba, F. A. (2017). Seasonal Variation of Radio Refractivity in Calabar, Nigeria. *International Journal of Scientific Research Engineering and Technology*. 6(6): 670-673.
- Ekonomou, L. (2010). Greek Long-term Energy Consumption Prediction using Artificial Neural Networks. *Journal of Energy:Elsevier*. 35(2): 512-517.
- El-Shafie, A. H., El-Shafie, A., El Mazoghi, H. G., Shehata, A. and Taha, M. R. (2011). Artificial Neural Network Technique for Rainfall Forecasting Applied to Alexandria, Egypt. *International Journal of Physical Sciences*. 6(6): 1306-1316.
- Elmolla, E. S., Chaudhuri, M. and Eltoukhy, M. M. (2010). The use of Artificial Neural Network (ANN) for Modeling of COD Removal from Antibiotic Aqueous Solution by the Fenton Process. *Journal of Hazardous Materials*. 179(1): 127-134.
- Erkaymaz, O., Özer, M., and Yumusak, N. (2014). Impact of Small-world Topology on the Performance of a Feed-forward Artificial Neural Network Based on 2 Different Real-Life Problems. *Turkish Journal of Electrical Engineering and Computer Science*. 22(30): 708-718.
- FAO. (2011). Grain Crop Drying, Handling and Storage *FAO*. <http://www.fao.org/docrep/015/i2433e/i2433e10>. Accessed on July 30, 2017

- Figueroa-Angulo, J. I., Savage, J., Bribiesca, E., Escalante, B. and Sucar, L. E. (2015). Compound Hidden Markov Model for Activity Labelling. *International Journal of Intelligence Science*. **5**(05): 177.
- Fuji, J. and Jayas, D. S. (2011). Temperature Monitoring. Kansas: Kansas State University.  
<http://entomology.k-state.edu/doc/finished-chapters/s156-ch-23-temperature-monitoring>.
- Funk, D. B., Gillay, Z. and Meszaros, P. (2007). Unified Moisture Algorithm for Improved RF Dielectric Grain Moisture Measurement. *Measurement Science and Technology*. **18**(4): 1004.
- Gaikwad, S. K., Gawali, B. W. and Yannawar, P. (2010). A Review on Speech Recognition Technique. *International Journal of Computer Applications*. **10**(3): 16-24.
- Galande, S., Agrawal, G. and Anap, M. (2015). A Parameter Monitoring and Control of Grain Storage by Embedded System. *International Journal of Informative and Futuristic Research*. **2**(11): 4172-4179.
- Garcia, D., Ramos, A. J., Sanchis, V. and Marín, S. (2009). Predicting Mycotoxins in Foods: A Review. *Food Microbiology*. **26**(8): 757-769.
- Gastón, A., Abalone, R., Bartosik, R. E. and Rodríguez, J. (2009). Mathematical Modelling of Heat and Moisture Transfer of Wheat Stored in Plastic Bags (Silobags). *Biosystems Engineering*. **104**(1): 72-85.
- Gona, R. and Venkateswarlu, P. (2015). Advanced System for Monitoring and Controlling of the Grain Condition Based on ARM7.
- Gonzales, H., Armstrong, P. and Maghirang, R. (2009a). Simultaneous Monitoring of Stored Grain with Relative Humidity, Temperature, and Carbon Dioxide Sensors. *Applied Engineering in Agriculture*. **25**(4): 595-604.
- Gonzales, H., Armstrong, P. and Maghirang, R. (2009b). Simultaneous Monitoring of Stored Grain with Relative Humidity, Temperature, and Carbon Dioxide Sensors. *Applied Engineering in Agriculture*. **25**(4): 595-604.

- Govindarajan, S., Jayas, D., White, N. and Paliwal, J. (2005). Dielectric Properties Measurement of Bulk Wheat Samples using Reflection and Transmission Techniques. In: the CSAE /SCGR 2005 Meeting, 26 to 29 June, 2005.
- Gowen, A. A., Tiwari, B. K., Cullen, P. J., McDonnell, K. and Donnell, C .P. O. (2010). Applications of Thermal Imaging in Food Quality and Safety Assessment. *Trend in Food Science and Technology*. **21**(4): 190-200.
- Greene, A. M., Robertson, A. W., Smyth, P. and Triglia, S. (2011). Downscaling Projections of Indian Monsoon Rainfall using a Non-homogeneous Hidden Markov Model. *Quarterly Journal of the Royal Meteorological Society*. **137**(655): 347-359.
- Greenspan, A. (2011). Measurements and Error Analysis. University of North Carolina.  
[http://www.websassign.net/question\\_assets/unccolphysmechl1/measurements/manual.html](http://www.websassign.net/question_assets/unccolphysmechl1/measurements/manual.html). Accessed on August 10, 2017
- Guo, W., Yang, J., Zhu, X., Wang, S. and Guo, K. (2013). Frequency, Moisture, Temperature, and Density-dependent Dielectric Properties of Wheat Straw. *Transactions of the ASABE*. **56**(3): 1069-1075.
- Hackl, W., Pieper, B., Pieper, R., Korn, U. and Zeyner, A. (2010). Effects of Ensiling Cereal Grains (Barley, Wheat, Rriticale and rye) on Total and Pre-caecal Digestibility of Proximate Nutrients and Amino Acids in Pigs. *Journal of Animal Physiology and Animal Nutrition*. **94**(6): 729-735.
- Hammerstein, P., Hagen, E. H., Herz, A. V. and Herzel, H. (2006). Robustness: A Key to Evolutionary Design. *Biological Theory*. **1**(1): 90-93.
- Hariprabha, V. and Vasantharathna, S. (2014). Monitoring and Control of Food Storage Depots using Wireless Sensor Networks. *International Journal of Industrial Electronics and Electrical Engineering*. **2**(6): 99-103.
- Hassan, M. R. and Nath, B. (2005). Stock Market Forecasting using Hidden Markov Model: A New Approach. In: the ISDA'05. Proceedings. 5th International Conference of the Intelligent Systems Design and Applications, Wroclaw, Poland, 8 to 10 September, 2005.

- Hassen, S. Z. S. (2006). Measurement and Error. University of Mauritius. <http://studylib.net/doc/8125652/measurement-and-error---university-of-mauritius>. Accessed on August 16, 2017
- Heigold, G., Deselaers, T., Schluter, R. and Ney, H. (2008). A GIS-like Training Algorithm for Log-linear Models with Hidden Variables. In: the 2008 IEEE International Conference on Acoustics, Speech and Signal Processing, Las Vegas, USA, 31 March to 4 April, 2008.
- Hou, L., Johnson, J. A. and Wang, S. (2016). Radio Frequency Heating for Postharvest Control of Pests in Agricultural Products: A Review: *Postharvest Biology and Technology*. **113**: 106-118.
- Hsiao, R., Tam, Y. C. and Schultz, T. (2009). Generalized Baum-Welch Algorithm for Discriminative Training on Large Vocabulary Continuous Speech Recognition System. In: the 2009 IEEE International Conference on Acoustics, Speech and Signal Processing, Taipei, Taiwan, 19 to 24 April, 2009.
- Huiling, Z., Yu, F. and Jingyun, L. (2011). Measuring and Controlling System for Validation of Grain Storage Mathematical Model Based on ZigBee Technology. *Applied Informatics and Communication*. **226**: 304-311.
- Iguaz, A., Arroqui, C., Esnoz, A. and Virseda, P. (2004). Modelling and Simulation of Heat Transfer in Stored Rough Rice with Aeration. *Biosystems Engineering*. **89**(1): 69-77.
- Iguaz, A. and Virseda, P. (2007). Moisture Desorption Isotherms of Rough Rice at High Temperatures. *Journal of Food Engineering*. **79**(3): 794-802.
- Ismail, N. and Asri, N. M. (2014). *Optimisation of Microwave System for Rice Treatment*. Thesis for Award of ME Degree at Universiti Tun Hussein Onn, Parit Raja, Malaysia, pp. 1-64.
- Isojunno, S. and Miller, P. J. (2016). Hidden Markov Models Capture Behavioral Responses to Suction-cup Tag Deployment: A Functional State Approach to Behavioral Context. *The Effects of Noise on Aquatic Life II: Springer*. **875**: 489-496.

- Jafari, F., Khalid, K., Yusoff, W. D. W. and Hassan, J. (2010). The Analysis and Design of Multi-layer Microstrip Moisture Sensor for Rice Grain. *Biosystems Engineering*. **106**(3): 324-331.
- Jamal, W., Das, S., Oprescu, I. A. and Maharatna, K. (2015). Prediction of Synchronstate Transitions in EEG Signals using Markov Chain Models. *Signal Processing Letters, IEEE*. **22**(2): 149-152.
- Jesse Davis, M. G. (2006). The Relationship Between Precision-Recall and ROC Curves. (1-8).In: Proceedings of the 23rd International Conference on Machine Learning, Pennsylvania, USA, 25 to 29 June, 2006.
- Jha, S. N., Narsaiah, K., Basediya, A., Sharma, R., Jaiswal, P., Kumar, R. and Bhardwaj, R. (2011). Measurement Techniques and Application of Electrical Properties for Nondestructive Quality Evaluation of Foods-a Review. *Journal of Food Science and Technology*. **48**(4): 387-411.
- Jiang, P. and Liu, X. (2016). Hidden Markov Model for Municipal Waste Generation Forecasting under Uncertainties. *European Journal of Operational Research*. **250**(2): 639-651.
- Jinshui, and Li. X. W. S. W. (2009). Progress of Research on Grain Equilibrium Moisture . *Journal of the Chinese Cereals and Oils Association*. **11**: 034.
- Johnson, M. J. and Willsky, A. S. (2013). Bayesian Nonparametric Hidden Semi-Markov Models. *Journal of Machine Learning Research*. **14**: 673-701.
- Jones, C. L., Stone, M. L., Maness, N. O., Solie, J. B. and Brusewitz, G. H. (2006). Plant Biomass Estimation using Dielectric Properties. In: the 2006 ASAE Annual Meeting, Oregon, Potland, 9 to 12 July, 2006.
- Jouany, J. P. (2007). Methods for Preventing, Decontaminating and Minimizing the Toxicity of Mycotoxins in Feeds. *Animal Feed Science and Technology*. **137**(3): 342-362.
- Kaatze, U. and Hübner, C. (2010). Electromagnetic Techniques for Moisture Content Determination of Materials. *Measurement Science and Technology*. **21**(8): 082001.

- Kabir, M. H., Hoque, M. R., Thapa, K. and Yang, S. H. (2016). Two-Layer Hidden Markov Model for Human Activity Recognition in Home Environments. *International Journal of Distributed Sensor Networks*. **2016**:015.
- Kaleta, A. and Górnicki, K. (2013a). Criteria of Determination of Safe Grain Storage Time-A Review. In: *Advances in Agrophysical Research: Edited by Dobrzański B, Grundas S and Stepniewski A*. InTech Publisher, Warsaw University. pp. 295-318.
- Kaleta, A. and Górnicki, K. (2013b). Criteria of Determination of Safe Grain Storage Time– A Review In: *Advances in Agrophysical Research: Edited by Dobrzański B, Grundas S and Stepniewski A*. InTech Publisher, Warsaw University. pp. 295-318.
- Kan-song, C., Pan, X., Chong, S. and Ke, C. (2014). Design of Environment Monitoring System in Grain Storage Based on ZigBee. *Internet of Things Technologies*. **2**: 028.
- Kanevsky, D., Nahamoo, D., Sainath, T. N., Ramabhadran, B. and Olsen, P. A. (2011). A-Functions: A Generalization of Extended Baum-Welch Transformations to Convex Optimization. In: *the 2011 IEEE International Conference on Acoustics, Speech and Signal Processing (ICASSP), Prague, Czech Republic, 22 to 27 May, 2011*.
- Kato, A. and Milner, B. (2014). Using Hidden Markov Models for Speech Enhancement. In: *the INTERSPEECH*.
- Khadr, M. (2016). Forecasting of Meteorological Drought using Hidden Markov Model (case study: The Upper Blue Nile River Basin, Ethiopia). *Ain Shams Engineering Journal*. **7**(1): 47-56.
- Khashei, M. and Bijari, M. (2010). An Artificial Neural Network Model for Timeseries Forecasting. *Expert Systems with Applications*. **37**(1): 479-489.
- Khatchatourian, O. and De Oliveira, F. (2006). Mathematical Modelling of Airflow and Thermal State in Large Aerated Grain Storage. *Biosystems Engineering*. **95**(2): 159-169.
- Khorgade, M. and Dakhole, P. (2015). Granary Environmental Monitoring System Using ZigBee and ARM Processor. *International Journal of Computer Science and Network*. **4**(3): 456 - 460.

- Kirsch, A. and Hettlich, F. (2014). The Mathematical Theory of Time-harmonic Maxwell's Equations: Expansion-, Integral-, and Variational Methods. Springer.,Karlsruhe. 337pp.
- Koehler, L. J., Ulmschneider, M. B. and Gray, J. J. (2015). Computational Modeling of Membrane Proteins. *Proteins: Structure, Function, and Bioinformatics*. **83**(1): 1-24.
- Kohlschein, C. (2006). An Introduction to Hidden Markov Models. Stanford.edu. <http://www.tcs.rwth-aachen.de/lehre/PRICS/WS2006/kohlschein>. Accessed on October 15, 2016.
- Komarov, V., Wang, S. and Tang, J. (2005). Permittivity and Measurements. *Encyclopedia of RF and Microwave Engineering*. **1002**(47): 3693-3711
- Krenker, A., Kos, A. and Bešter J. (2011). Introduction to the Artificial Neural Networks. In: *Artificial Neural Networks - Methodological Advances and Biomedical Applications: Edited by Kenji S.* Intech Open Access Publisher, University of Ljubljana.pp. 4-18.
- Kriti, S. R. W. and Mayur, N. (2015). Weather Prediction Using Hidden Markov Model. *International Journal of Electronics and Communication Engineering (SSRG-IJECE)*. **2**(3): 61-63.
- Kueh, S. M. and Kuok, K. K. (2016). Precipitation Downscaling using the Artificial Neural Network BatNN and Development of Future Rainfall Intensity-duration-frequency Curves. *Climate Research*. **68**(1): 73-89.
- Kumar, S., Hiremath, V. and Rakhee, K. (2012). Smart Sensor Network System Based on ZigBee Technology to Monitor Grain Depot. *International Journal of Computer Applications*. **50**(21):32-36.
- Lampros, C., Papaloukas, C., Exarchos, T. P., Goletsis, Y. and Fotiadis, D. I. (2007). Sequence-based Protein Structure Prediction using a Reduced State-space Hidden Markov model. *Computers in Biology and Medicine*. **37**(9): 1211-1224.
- Li, S. T. and Cheng, Y. C. (2006). A Hidden Markov Model-based Forecasting Model for Fuzzy Time Series. *WSEAS Transactions on Systems*. **5**(8): 1919-1924.



- Li, X., Cao, Z., Wei, Z., Feng, Q. and Wang, J. (2011). Equilibrium Moisture Content and Sorption Isothermic Heats of Five Wheat Varieties in China. *Journal of Stored Products Research*. **47**(1): 39-47.
- Li, X. and Xu, C. (2012). Environmental Monitoring System for Grain Storage Based on WSN. *Instrument Technique Sensor*(7). **7**: 38-41.
- Liang, K., Shen, M., Lu, S., Liu, Z. and Li, X. (2013). Real-time Monitoring System for Grain Moisture Content Based on Equilibrium Moisture Model. *Nongye Jixie Xuebao(Transactions of the Chinese Society of Agricultural Machinery)*. **44**(1): 125-130.
- Lin, J. C. and Michaelson, S. M. (2013). Biological Effects and Health Implications of Radiofrequency Radiation. Springer Science and Business Media., New York. 674pp
- Liu, H., Liao, G. P. and Yang, F. (2008). Application of Wireless Sensor Network in Agriculture Producing [J]. *Agriculture Network Information*. **11**: 16-18.
- Liu, T. (2010). Application of Markov Chains to Analyze and Predict the Time Series. *Modern Applied Science*. **4**(5): 162.
- Lohani, A. K., Goel, N. and Bhatia, K. (2011). Comparative Study of Neural Network, Fuzzy Logic and Linear Transfer Function Techniques in Daily Rainfall-runoff Modelling under Different Input Domains. *Hydrological Processes*. **25**(2): 175-193.
- Lu, L., Gao, S., Li, Y., Min, X. L. and Wang, G. F. (2011). Design and Implementation of Monitoring System for Condition of Stored-grain. *Computer Engineering*. **12**: 087.
- Lu, Y. and Qin, S. (2010). Stored-grain Insect Image Processing Based on a Hidden Markov Model. In: *the ICECE '10 Proceedings of the Electrical and Control Engineering (ICECE), 2010 International Conference, Washington, DC, USA, 25 to 27 June, 2010*.
- Mabrouk, S., Abdelmonsef, A. and Toman, A. (2017). Smart Grain Storage Monitor and Control. *American Scientific Research Journal for Engineering, Technology, and Sciences (ASRJETS)*. **31**(1): 156-162.

- Mackworth, D. P. A. (2010). Hidden Markov Models. Artificial Intelligence Foundation of Computational Agents. [http://artint.info/html/ArtInt\\_161.html](http://artint.info/html/ArtInt_161.html). Accessed on October 2016.
- Magan, N. and Aldred, D. (2007). Post-harvest Control Strategies: Minimizing Mycotoxins in the Food Chain. *International Journal of Food Microbiology*. **119**(1): 131-139.
- Maier, D., Channaiah, L., Martinez-Kawas, A., Lawrence, J., Chaves, E., Coradi, P. and Fromme, G. (2010). Monitoring Carbon Dioxide Concentration for Early Detection of Spoilage in Stored Grain. In: *10th International Working Conference on Stored Product Protection, Estoril, Portugal, 27 June to 2 July, 2010*.
- Majewska, K., Banach, J. K., Żywica, R. and Białobrzewski, I. (2008). Influence of Variety, Moisture Content, Kernel Size and Applied Current Frequency on the Electric Properties of Wheat grain. *International Journal of Food Properties*. **11**(2): 392-406.
- Makalle, M. (2012). Post Harvest Storage as a Rural Household Food Security Strategy in Tanzania. *ARPN Journal of Science and Technology*. **12**(9): 814-821.
- Mallya, G., Tripathi, S. and Govindaraju, R. S. (2012). *Hidden Markov Model-based Probabilistic Assessment of Droughts*: American Society of Civil Engineers, Purdue University. <http://docs.lib.purdue.edu/dissertations/AAI1501880/>. Accessed on 2 September, 2016.
- Mallya, G., Tripathi, S., Kirshner, S. and Govindaraju, R. S. (2012). Probabilistic Assessment of Drought Characteristics using Hidden Markov Model. *Journal of Hydrologic Engineering*. **18**(7): 834-845.
- Mandal, K., Padhi, J., Kumar, A., Ghosh, S., Panda, D., Mohanty, R. and Raychaudhuri, M. (2015). Analyses of Rainfall using Probability Distribution and Markov Chain Models for Crop Planning in Daspalla Region in Odisha, India. *Theoretical and Applied Climatology*. **121**(3-4): 517-528.
- Marwala, T., Mahola, U. and Nelwamondo, F. V. (2006). Hidden Markov Models and Gaussian Mixture Models for Bearing Fault Detection using Fractals. In: *the Proceedings of the The 2006 IEEE International Joint Conference on Neural Network, Vancouver, BC, Canada, 16 to 21 July, 2006*.

- Mendez, M. O., Matteucci, M., Castronovo, V., Ferini-Strambi, L., Cerutti, S. and Bianchi, A. (2010). Sleep Staging from Heart Rate Variability: Time-varying Spectral Features and Hidden Markov Models. *International Journal of Biomedical Engineering and Technology*. **3**(3): 246-263.
- Momenzadeh, L. and Zomorodian, A. (2011). Study of Shelled Corn Shrinkage in a Microwave-assisted Fluidized Bed Dryer using Artificial Neural Network. *International Journal of Agriculture Sciences*. **4**(1): 172-175.
- Monbaliu, S., Van Poucke, C., Detavernier, C. I., Dumoulin, F., Van, D. V. M., Schoeters, E. and De Saeger, S. (2009). Occurrence of Mycotoxins in Feed as Analyzed by a Multi-mycotoxin LC-MS/MS Method. *Journal of Agricultural and Food Chemistr*. **58**(1): 66-71.
- Moura, E. E., Berbert, P. A., Souza, E. F., Garcia, R. F., Molina, M. A. and Oliveira, M. R. (2016). Frequency, Moisture Content, Bulk Density and Hybrid Effects on Grain Sorghum Dielectric Properties. *Agricultural Engineering International: CIGR Journal*. **18**(1): 236-255.
- Müller, C. (2013). Foundations of the Mathematical Theory of Electromagnetic Waves. Springer Science and Business Media., Berlin. 353pp.
- Nagel, M. and Börner, A. (2010). The Longevity of Crop Seeds Stored under Ambient Conditions. *Seed Science Research*. **20**(1): 1-12.
- Nath K, D. and Ramanathan, P. (2017). Non-destructive Methods for the Measurement of Moisture Contents– A Review. *Sensor Review*. **37**(1): 71-77.
- Nathan Lazarus, S. S. B. and Chiung-C. Lo, G. K. F. (2010). CMOS-MEMS Capacitive Humidity Sensor. *Journal of Microelectromechanical Systems*. **19**(1): 183 - 191.
- Navarro, H. and Bennun, L. (2014). Descriptive Examples of the Limitations of Artificial Neural Networks Applied to the Analysis of Independent Stochastic Data. *Cornell University Library*. **1404**: 5598.
- Nelson, S. (2008). Dielectric Properties of Agricultural Products and Some Applications. *Research in Agricultural Engineering*. **54**(2): 104-112.

- Nelson, S. O. (2010). Fundamentals of Dielectric Properties Measurements and Agricultural Applications. *J. Microw. Power Electromagn. Energy*. **44**(2): 98-113.
- Nelson, S. O. and Trabelsi, S. (2008). Influence of Water Content on RF and Microwave Dielectric Behavior of Foods. *Journal of Microwave Power and Electromagnetic Energy*. **43**(2): 13-23.
- Nelson, S. O. and Trabelsi, S. (2009). Influence of Water Content on RF and Microwave Dielectric Behavior of Foods. *J. Microw. Power Electromagn. Energy*. **43**(2): 13-23.
- Nelson, S. O. and Trabelsi, S. (2012). Factors Influencing the Dielectric Properties of Agricultural and Food Products. *Journal of Microwave Power and Electromagnetic Energy*. **46**(2): 93-107.
- Netzer, O., Lattin, J. M. and Srinivasan, V. (2008). A Hidden Markov Model of Customer Relationship Dynamics. *Marketing Science*. **27**(2): 185-204.
- Nguyeny, T., Mark, B. L. and Ephraim, Y. (2011). Hidden Markov Process Based Dynamic Spectrum Access for Cognitive Radio. In: *the Information Sciences and Systems (CISS), 2011 45th Annual Conference, Baltimore, MD, USA, 23 to 25 March, 2011*.
- Oliveira, M. and Franca, A. (2002). Microwave Heating of Foodstuffs. *Journal of Food Engineerin*. **53**(4): 347-359.
- Onibonoje, M. O., Alli, K. S., Olowu, T. O., Ogunlade, M. A. and Akinwumi, A. O. (2016). Resourceful Selection-Based Design of Wireless Units for Granary Monitoring Systems. *ARPJ Journal of Engineering and Applied Sciences*. **11**(23): 13754-13759
- Onibonoje, M. O., Kehinde, L. O. and Owolarafe, O. (2015). A Wireless Sensor Network for Controlling the Effect of the Moisture Content in Stored Maize Grains. *International Journal of Engineering Research and Technology*. **4**(10): 141-147.
- Osman, J., Inglada, J. and Dejoux, J.-F. (2015). Assessment of a Markov Logic Model of Crop Rotations for Early Crop Mapping. *Computers and Electronics in Agriculture*. **113**: 234-243.
- Östmark, Å (2004). Embedded Internet System Architectures. Thesis for Award of Doctor of Philosophy Degree at Luleå University of Technology, Luleå, Sweden, pp. 1-109

- Othman, M. B. H., Ramli, M. R., Tyng, L. Y., Ahmad, Z. and Akil, H. M. (2011). Dielectric Constant and Refractive Index of Poly (Siloxane–imide) Block Copolymer. *Materials and Design*. **32**(6): 3173-3182.
- Ozerov, A., Févotte, C. and Charbit, M. (2009). Factorial Scaled Hidden Markov Model for Polyphonic Audio Representation and Source Separation. In: *the 2009 IEEE Workshop on Applications of Signal Processing to Audio and Acoustics, New Paltz, NY, USA, 18 to 21 October, 2009*
- Pal, I., Robertson, A. W., Lall, U. and Cane, M. A. (2015). Modeling Winter Rainfall in Northwest India using a Hidden Markov Model: Understanding Occurrence of Different States and their Dynamical Connections. *Climate Dynamics*. **44**(34):1003-1015.
- Partal, T., Cigizoglu, H. K. and Kahya, E. (2015). Daily Precipitation Predictions using Three Different Wavelet Neural Network Algorithms by Meteorological Data. *Stochastic Environmental Research and Risk Assessment*. **29**(5): 1317-1329.
- Parviz, T. K. S. (2010). Determination of Dielectric Properties of Wheat in Various Moisture Contents with a Parallel-Plate and Cylindrical Coaxial Capacitor. *Natural and Applied Sciences*. **61**: 552-558.
- Paterson, R. R. M. and Lima, N. (2010). How will Climate Change Affect Mycotoxins in Food? *Food Research International*. **43**(7): 1902-1914.
- Pawan, K., Yadava, R., Babita, G., Sandeep, K., Ravi Kant, V. and Sanja, Y. (2011). Nutritional Contents and Medicinal Properties of Wheat. *Life Sciences and Medicine Research*. **2011**: 1-10
- Pierson, K., Macdonald, B. and Penner, J. (2009). Grain Drying Aeration System. *IFI Claims Patent Services*. **782**: 1-11.
- Pineda, L. E. and Willems, P. (2016). Multisite Downscaling of Seasonal Predictions to Daily Rainfall Characteristics over Pacific–Andean River Basins in Ecuador and Peru Using a Nonhomogeneous Hidden Markov Model. *Journal of Hydrometeorology*. **17**(2): 481-498.

- Pollatos, E. P., Riganakos, K. A. and Demertzis, P. G. (2013). Moisture Sorption Characteristics of Greek Durum Wheat Semolina. *Starch-Stärke*. **65**(11): 1051-1060.
- Ponomaryova, M. I. (2011). Model of Electromagnetic Interaction with Granular Product and Insects. Thesis for Award of Doctor of Philosophy Degree at National Polytechnic Institute. Mexico city, Mexico, pp. 1-106.
- Pradhan, B. and Lee, S. (2010). Landslide Susceptibility Assessment and Factor Effect Analysis: Backpropagation Artificial Neural Networks and their Comparison with Frequency Ratio and Bivariate Logistic Regression Modelling. *Environmental Modelling and Software*. **25**(6): 747-759.
- Prakash, S., Jha, S. and Datta, N. (2004). Performance Evaluation of Blanched Carrots Dried by Three Different Driers. *Journal of Food Engineering*. **62**(3): 305-313.
- Prandini, A., Sigolo, S., Filippi, L., Battilani, P. and Piva, G. (2009). Review of Predictive Models for Fusarium Head Blight and Related Mycotoxin Contamination in Wheat. *Food and Chemical Toxicology*. **47**(5): 927-931.
- Rahman, M. S. (Ed.) (2007). *Handbook of food Preservation*: CRC press, New York. 1088pp.
- Rai, A., Khare, P. and Mor, P. (2007). Microprocessor Based Measurement System for Grain Moisture. In: *IET-UK International Conference on Information and Communication technology in Electrical Science, 002 International Conference, Tamil Nadu, India, 20 to 22 December, 2007*.
- Rajarammanna, R., Jayas, D. and White, N. (2010). Comparison of Deterioration of Rye under Two Different Storage Regimes. *Journal of Stored Products Research*. **46**(2): 87-92.
- Raji, A. and Ojediran, J. (2011). Moisture Sorption Isotherms of Two Varieties of Millet. *Food and Bioproducts Processing*. **89**(3): 178-184.
- Ramana, R. V., Krishna, B., Kumar, S. and Pandey, N. (2013). Monthly Rainfall Prediction using Wavelet Neural Network Analysis. *Water Resources Management*. **27**(10): 3697-3711.

- Ramaswamy, H. and Tang, J. (2008). Microwave and Radio Frequency Heating. *Food Science and Technology International*. **14**(5): 423-427.
- Ramesh, N., Thayakaran, R. and Onof, C. (2013). Multi-site Doubly Stochastic Poisson Process Models for Fine-scale Rainfall. *Stochastic Environmental Research and Risk Assessment*. **27**(6): 1383-1396.
- Ricardo, A. R. L. C. P. (2011). Models of Sorption Isotherms for Food: Uses and Limitations. *Vitae, Revista de la Facultad de Quomica Farmac*. **18**(3): 325-334.
- Richard, J. L. (2007). Some Major Mycotoxins and their Mycotoxicoses—An Overview. *International Journal of Food Microbiology*. **119**(1): 3-10.
- Ross, S. M. (Ed.) (2014). Introduction to Probability Models: Academic press, California. 801pp
- Sacilik, K. and Colak, A. (2010). Determination of Dielectric Properties of Corn Seeds from 1 to 100 MHz. *Powder Technology*. **203**(2): 365-370.
- Sadhu, A., Prakash, G. and Narasimhan, S. (2016). A Hybrid Hidden Markov Model towards Fault Detection of Rotating Components. *Journal of Vibration and Control*. **23**(19).3175-3195
- Safa, M., Samarasinghe, S. and Nejat, M. (2015). Prediction of Wheat Production using Artificial Neural Networks and Investigating Indirect Factors Affecting It: Case Study in Canterbury Province, New Zealand. *Journal of Agricultural Science and Technology*. **17**(4): 791-803.
- Safouane, M., Saida, N., Sihem, J. and Mohamed, S. (2016). Using the Markov Chain for the Generation of Monthly Rainfall Series in a Semi-Arid Zone. *Open Journal of Modern Hydrology*. **2016**(6): 51-65.
- Savi, G. D., Piacentini, K. C., Bittencourt, K. O. and Scussel, V. M. (2014). Ozone Treatment Efficiency on Fusarium Graminearum and Deoxynivalenol Degradation and its Effects on Whole Wheat Grains (*Triticum aestivum* L.) quality and germination. *Journal of Stored Products Research*. **59**: 245-253.

- Sawant, A. A., Patil, S., Kalse, S. and Thakor, N. (2012). Effect of Temperature, Relative Humidity and Moisture Content on Germination Percentage of Wheat Stored in Different Storage Structures. *Agricultural Engineering International: CIGR Journal*. **14**(2): 110-118.
- Scott, S. L. (2011). Bayesian Methods for Hidden Markov Models. *Journal of the American Statistical Association*. **2000**(1): 1-35
- Sekhar, T. C. and Swetha, G. N. (2013). The Design of Granary Environmental Monitoring System Based on ARM7 and ZigBee. *International Journal of Computer Science and Mobile Computing*. **2**(12): 198-205.
- Serdyuk, V. M. (2008). Dielectric Study of Bound Water in Grain at Radio and Microwave Frequencies. *Progress In Electromagnetics Research*. **84**: 379-406.
- Shen, Y., Di, L., Wu, L., Yu, G., Tang, H. and Yu, G. (2012). Hidden Markov Models for Corn Progress Percents Estimation in Multivariate Time Series. In: *the Agro-Geoinformatics (Agro-Geoinformatics), 2012 First International Conference, Shanghai Jiao Tong University*  
*Shanghai, China, 2 to 4 August, 2012.*
- Shena, J., Yanga, M., Zhongb, R. and Zhange, C. (2011). A Hidden Markov Model Based Method for Anomaly Detection of Precipitation Series. *Journal of Information and Computational Science*. **8**(9):1551-1560.
- Shrestha, B. and Baik, O.-D. (2013). Radio Frequency Selective Heating of Stored-grain Insects at 27.12 MHz: A Feasibility Study. *Biosystems Engineering*. **114**(3): 195-204.
- Shrestha, B. and Baik, O. (2015). Dielectric Behaviour of Whole-grain Wheat with Temperature at 27.12 MHz: A Novel use of a Liquid Dielectric Test Fixture for Grains. *International Journal of Food Properties*. **18**(1): 100-112.
- Silva, C. S. and Sonnadara, U. (2013). Classification of Rice Grains using Neural Networks. In: *the Proceedings of 29th Technical Sessions, Kelaniya, Sri Lanka, March, 2013*
- Silva, E. d. S., Leão, R. M. M. and Muntz, R. R. (2011). Performance Evaluation with Hidden Markov Models. In: *the PERFORM'10 Proceedings of the 2010 IFIP WG*



6.3/7.3 International Conference on Performance Evaluation of Computer and Communication Systems: milestones and future challenges: Springer, Vienna, Austria, 14 to 16, 2010

- Simon, D., Ergezer, M., Du, D. and Rarick, R. (2011). Markov Models for Biogeography-Based Optimization. *Systems, Man, and Cybernetics, Part B: Cybernetics, IEEE Transactions on.* **41**(1): 299-306.
- Singh, R., Patel, C., Yadav, M., Singh, P. and Singh, K. (2014). Weekly Rainfall Analysis and Markov Chain Model Probability of Dry and Wet Weeks at Varanasi in Uttar Pradesh. *Environment and Ecology.* **32**(3): 885-890.
- Siu, M. H., Gish, H., Chan, A., Belfield, W. and Lowe, S. (2014). Unsupervised Training of an HMM-based Self-organizing Unit Recognizer with Applications to Topic Classification and Keyword Discovery. *Computer Speech and Language.* **28**(1): 210-223.
- Skalny, P. and Krajc, B. (2013). Discrete-Time Markov Chains in Reliability Analysis-Case Study. In: *the International Joint Conference CISIS'12-ICEUTE' 12-SOCO' 12 Special Sessions, Berlin, Germany, December, 2013.*
- Soltani, M. and Alimardani, R. (2011). Prediction of Corn and Lentil Moisture Content using Dielectric Properties. *Journal of Agricultural Technology.* **7**(5): 1223-1232.
- Soltani, M. and Alimardani, R. (2013a). Investigation of the Relationship between Moisture Content and Dielectric Constant of Wheat and Millet. *Journal of Scientific and Industrial Research.* **72**(07): 415-418.
- Soltani, M., and Alimardani, R. (2013b). Investigation of the Relationship between Moisture Content and Dielectric Constant of Wheat and Millet. *Journal of Scientific and Industrial Research.* **72**(07): 415-418
- Sonnadara, D. and Jayewardene, D. (2015). A Markov Chain Probability Model to Describe Wet and Dry Patterns of Weather at Colombo. *Theoretical and Applied Climatology.* **119**(1-2): 333-340.

- Sosa-Morales, M., Valerio-Junco, L., López-Malo, A. and García, H. (2010). Dielectric Properties of Foods: Reported Data in the 21st Century and their Potential Applications. *LWT-Food Science and Technology*. **43**(8): 1169-1179.
- Streit, E., Schatzmayr, G., Tassis, P., Tzika, E., Marin, D., Taranu, I., and Puel, O. (2012). Current Situation of Mycotoxin Contamination and Co-occurrence in Animal Feed—Focus on Europe. *Toxins*. **4**(10): 788-809.
- Striccoli, D., Boggia, G. and Grieco, L. A. (2015). A Markov Model for Characterizing IEEE 802.15. 4 MAC Layer in Noisy Environments. *Industrial Electronics, IEEE Transactions on*. **62**(8): 5133-5142.
- Surendra, M. and Kishore, G. K. (2014). The Design of Granary Environment Monitoring through Web Server Based on ARM-9 and Zigbee. *International journal of Advanced Technology and Innovative Research*. **6**(12): 1552-1555.
- Tabari, H., Zamani, R., Rahmati, H. and Willems, P. (2015). Markov Chains of Different Orders for Streamflow Drought Analysis. *Water Resources Management*. **29**(9): 3441-3457.
- Tan, W. L., Yusof, F. and Yusop, Z. (2016). Subseasonal to Multidecadal Variability of Northeast Monsoon Daily Rainfall over Peninsular Malaysia using a Hidden Markov Model. *Theoretical and Applied Climatology*. **10**(1-10): 577-586.
- Tang, J. and Wang, S. e (2007). Temperature Measurement. In: *Heat Treatments for Postharvest Pest Control: Theory and Practice: Edited by Tang, J., Mitcham, E., Wang, S., and Lurie, S.* Cromwell Press Publisher, Massachusetts, pp. 56-77
- Tatavarty, A.S. (2011). Topic Detection and Tracking using Hidden Markov Models. Thesis for Award of MSc Degree at University of Nevada, Las Vegas, USA, pp. 1-62.
- Tefera, T. and Abass, A. (2012). Improved Postharvest Technologies for Promoting Food Storage, Processing, and Household Nutrition in Tanzania. In: *theAfrica RISING East and Southern Africa Review and Planning Meeting, Arusha, Tanzania, 1 to 5 October, 2012.*

- Tefera, T., Kanampiu, F., De, G. H. Hellin, J., Mugo, S., Kimenju, S. and Banziger, M. (2011). The metal silo: An Effective Grain Storage Technology for Reducing Post-harvest Insect and Pathogen Losses in Maize while Improving Smallholder Farmers' Food Security in Developing Countries. *Crop Protection*. **30**(3): 240-245.
- Thakur, R., Chatterji, S., Kumar, A. and Bansod, B. (2014). Development of Multi-grain Capacitive Sensor for Determination of Moisture Content in Grains. *Quality Assurance and Safety of Crops and Foods*. **7**(2): 201-206.
- Thakur, R., Chatterji, S., Kumar, A. and Bansod, B. S. (2011). Studies on Electrical Properties of Wheat as a Function of Moisture Content. *Quality Assurance and Safety of Crops and Foods*. **3**(4): 198-204.
- Titsias, M. K., Holmes, C. C. and Yau, C. (2016). Statistical Inference in Hidden Markov Models using K-segment Constraints. *Journal of the American Statistical Association*. **111**(513): 200-215.
- Tobon-Mejia, D. A., Medjaher, K., Zerhouni, N. and Tripot, G. (2012). A Data-driven Failure Prognostics Method Based on Mixture of Gaussians Hidden Markov Models. *IEEE Transactions on Reliability*. **61**(2): 491-503.
- Tom Kearney, S. G. and Lee Jackson. 2006 . Harvesting and Storage. *Small Grain Production, University of California*. <http://anrcatalog.ucanr.edu/>. Accessed on January 17, 2017
- Torrealba-Meléndez, R., Sosa-Morales, M. E., Olvera-Cervantes, J. L. and Corona-Chávez, A. (2015). Dielectric Properties of Cereals at Frequencies useful for Processes with Microwave Heating. *Journal of Food Science and Technology*. **52**(12): 8403-8409.
- Trabelsi, S. and Nelson, S. (2012). Microwave Dielectric Properties of Cereal grains. *Transactions of the ASABE*. **55**(5): 1989-1996.
- Trabelsi, S., Nelson, S. and Lewis, M. (2008). Microwave Moisture Sensor for Grain and Seed. *Biological Engineering Transactions*. **1**(2): 195-202.
- Trabelsi, S., Nelson, O. and Lewis, M. (2008). Practical Microwave Meter for Sensing Moisture and Density of Granular Materials. In: *the Proceedings of 2008 IEEE*

*Instrumentation and Measurement Technology Conference, Victoria, Canada, May, 2008*

- Trentin, E. and Gori, M. (2001). A Survey of Hybrid ANN/HMM Models for Automatic Speech Recognition. *Neurocomputing*. **37**(1): 91-126.
- Troffaes, M. and Paton, L. (2013). Logistic Regression on Markov Chains for Crop Rotation Modelling. In: *the 8th International Symposium on Imprecise Probability: Theories and Applications, Compi`egne, France, 2 to 3 July, 2013*
- Tumilaar, K., Langi, Y. and Rindengan, A. (2015). Hidden Markov Model. *De Cartesian*. **4**(1): 86-84.
- Uddin, M., Armstrong, P. and Zhang, N. (2006). Accuracy of Grain Moisture Content Prediction using Temperature and Relative Humidity Sensors. *Applied engineering in agriculture*. **22**(2): 267-273.
- Vamitha, V., Jeyanthi, M., Rajaram, S. and Revathi, T. (2012). Temperature Prediction using Fuzzy Time Series and Multivariate Markov Chain. *International Journal of Fuzzy Mathematics and Systems*. **2**(3): 217-230.
- Verbist, K., Robertson, A. W., Cornelis, W. M. and Gabriels, D. (2010). Seasonal Predictability of Daily Rainfall Characteristics in Central Northern Chile for Dry-land Management. *Journal of Applied Meteorology and Climatology*. **49**(9): 1938-1955.
- Vinayaka H, R. J. (2016). Intelligent System for Monitoring and Controlling Grain Condition Based on ARM 7 Processor. *International Journal of Latest Technology in Engineering, Management and Applied Science*. **5**(7): 6 - 10.
- Visser, I. and Speekenbrink, M. (2010). depmixS4: An R-package for Hidden Markov Models. *Journal of Statistical Software*. **36**(7): 1-21.
- Wagacha, J. and Muthomi, J. (2008). Mycotoxin Problem in Africa: Current Status, Implications to Food Safety and Health and Possible Management Strategies. *International Journal of Food Microbiology*. **124**(1): 1-12.

- Wambugu, P., Mathenge, P., Auma, E. and Van Rheenen, H. (2009). Efficacy of Traditional Maize (*Zea mays* L.) Seed Storage Methods in Western Kenya. *African Journal of Food, Agriculture, Nutrition and Development*. **9**(4): 1110-1128.
- Wang, B., Guo, J. and Su, D. (2014). An Improved Green Energy Granary Monitoring System Based on Wireless Sensor Network. *Sensors and Transducers*. **180**(10): 89-96.
- Wang, F., Tan, S., Yang, Y. and Shi, H. (2016). Hidden Markov Model-based Fault Detection Approach for Multimode Process. *Industrial and Engineering Chemistry Research*. **55**(16): 4613-4621.
- Wang, L., Chen, T. Y., Lin, K. H., Fang, Q. and Lee, S.-Y. (2015). Implementation of a Wireless ECG acquisition SoC for IEEE 802.15. 4 (ZigBee) Applications. *IEEE Journal of Biomedical and Health Informatics*. **19**(1): 247-255.
- Wang, W. and Wang, L. (2012). Design of Moisture Content Detection System. *Physics Procedia*. **33**(2012): 1408-1411
- Wang, X., Xia, M., Cai, H., Gao, Y. and Cattani, C. (2012). Hidden Markov Models Based Dynamic Hand Gesture Recognition. *Mathematical Problems in Engineering*. **2012**(2012):1-11.
- Wang, Y., Liu, J., Wang, P. X., Han, P., Zhu, D. H. and Zhang, S. Y. (2007). Prediction of Drought Occurrence Based on the Standardized Precipitation Index and the Markov Chain Model with Weights. *Agricultural Research in the Arid Areas*. **5**(2007): 198-203.
- Wang, Y., Zhang, L., Gao, M., Tang, J. and Wang, S. (2013). Temperature and Moisture Dependent Dielectric Properties of Macadamia Nut Kernels. *Food and Bioprocess Technology*. **6**(8): 2165-2176.
- Were, K., Bui, D. T., Dick, Ø. B. and Singh, B. R. (2015). A Comparative Assessment of Support Vector Regression, Artificial Neural Networks, and Random Forests for Predicting and Mapping Soil Organic Carbon Stocks Across an Afromontane Landscape. *Ecological Indicators*. **52**(2015): 394-403.

- Wu, C. and Chau, K. (2011). Rainfall–runoff Modeling using Artificial Neural Network Coupled with Singular Spectrum Analysis. *Journal of Hydrology*. **399**(3): 394-409.
- Wu, F., Bhatnagar, D., Bui-Klimke, T., Carbone, I., Hellmich, R., Munkvold, G. and Takle, E. (2011). Climate Change Impacts on Mycotoxin Risks in US Maize. *World Mycotoxin Journal*. **4**(1): 79-93.
- Xiong, D., Liu, R., Xiao, F. and Gao, X. (2014). ProMT: Effective Human Promoter Prediction Using Markov Chain Model Based on DNA Structural Properties. *NanoBioscience, IEEE Transactions on*. **13**(4): 374-383.
- Yang, B., Yao, L. and Huang, H. Z. (2007). Early Software Quality Prediction Based on a Fuzzy Neural Network Model. In: *the Third International Conference on Natural Computation (ICNC 2007), Haikou, China, 24 to 27 August, 2007*.
- Yang, L., Mao, Z. and Dong, L. (2010). Development of Plane Polar Probe of Capacitive Grain Moisture Sensor. *Transactions of the Chinese Society of Agricultural Engineering*. **26**(2): 185-189.
- Yasar, A., Kaya, E. and Saritas, I. (2016). Classification of Wheat Types by Artificial Neural Network. *International Journal of Intelligent Systems and Applications in Engineering*. **4**(1): 12-15.
- Yi, C. and Bai, F. (2011). ZigBee-based CC2530 Granary Temperature and Humidity Monitoring System. *Journal of Changchun University of Science and Technology (Natural Science Edition)*. **4**(2011): 200-216.
- Yuan, Q. (2015). Granary Temperature and Humidity Measurement System based on Zigbee Network. *IJW*. **7**(4): 138-144.
- Yusof, F., Kane, I. L. and Yusop, Z. (2015). Measuring Volatility Persistence on Rainfall Records with the Hybrid of Autoregressive Fractional Integrated Moving Average (ARFIMA)-hidden Markov Model (HMM). In: *the The 2nd ISM International Statistical Conference 2014 (ISM-II): Empowering the Applications of Statistical and Mathematical Sciences, Universiti Malaysia, Malaysia, 12 to 14 August, 2014*.

- Zhang, F., Zhou, H. and Zhou, X. (2009). Simulation of Temperature Measurement System for Grain Storage Based on ZigBee Technology. In: *the Computer Science and Information Technology, 2009. ICCSIT 2009. 2<sup>nd</sup> IEEE International Conference, Beijing, China*, 8 to 11 August, 2009.
- Zhang, G. P. (2003). Time Series Forecasting using a Hybrid ARIMA and Neural Network Model. *Neurocomputing*. **50**(2003): 159-175.
- Zhang, L., Yuan, M., Tai, D., Ding, J., Xu, X., Zhen, X. and Zhang, Y. (2010). Design and Implementation of Granary Monitoring System Based on Wireless Sensor Network Node. In: *the Measuring Technology and Mechatronics Automation (ICMTMA), 2010 International Conference, Changsha City, China*, 13 to 14 March, 2010
- Zheng, A., Zhang, B., Zhou, L. and Wang, S. (2016). Application of Radio Frequency Pasteurization to Corn (*Zea mays* L.): Heating Uniformity Improvement and Quality Stability Evaluation. *Journal of Stored Products Research*. **68**(2016): 63-72.
- Zheng, M., Zheng, B. and Zhang, H. (2015). Feasibility Research of Infinite State Markov Chain Technique in Variable-frequency Speed Control System. In: *the 2015 International Industrial Informatics and Computer Engineering Conference, Xi'an, Shaanxi, China*, 10 to 11 January, 2015.
- Zhong, S. and Ghosh, J. (2001). A New formulation of Coupled Hidden Markov Models. *Electrical and Computer Engineering*. **1084**(2001):1-19.
- Zhou, B., Wang, J. and Qi, J. (2012). Identification of Different Wheat Seeds by Electronic Nose. *International Agrophysics*. **26**(4): 413-418.
- Zhou, H., Zhang, F., Liu, J. and Zhang, F. (2009). A Real-time Monitoring and Controlling System for Grain Storage with ZigBee Sensor Network. In: *the Wireless Communications, Networking and Mobile Computing, 2009. WiCom'09. 5th International Conference, Beijing, China*, 24 to 26 September, 2009
- Zhou, H., Chen, X., Liu, X. and Yang, J. (2008). Applications of Zigbee Wireless Technology to Measurement System in Grain Storage. In: *the International Conference on Computer and Computing Technologies in Agriculture, Beijing, China*, 18 to 20 October, 2008.

Zhu, X., Guo, W. and Wang, S. (2013). Sensing Moisture Content of Buckwheat Seed from Dielectric Properties. *Transactions of the ASABE*. **56**(5): 1855-1862.



## APPENDICES

**Appendix I: Grain Storage Condition Monitoring Model Flowchart**

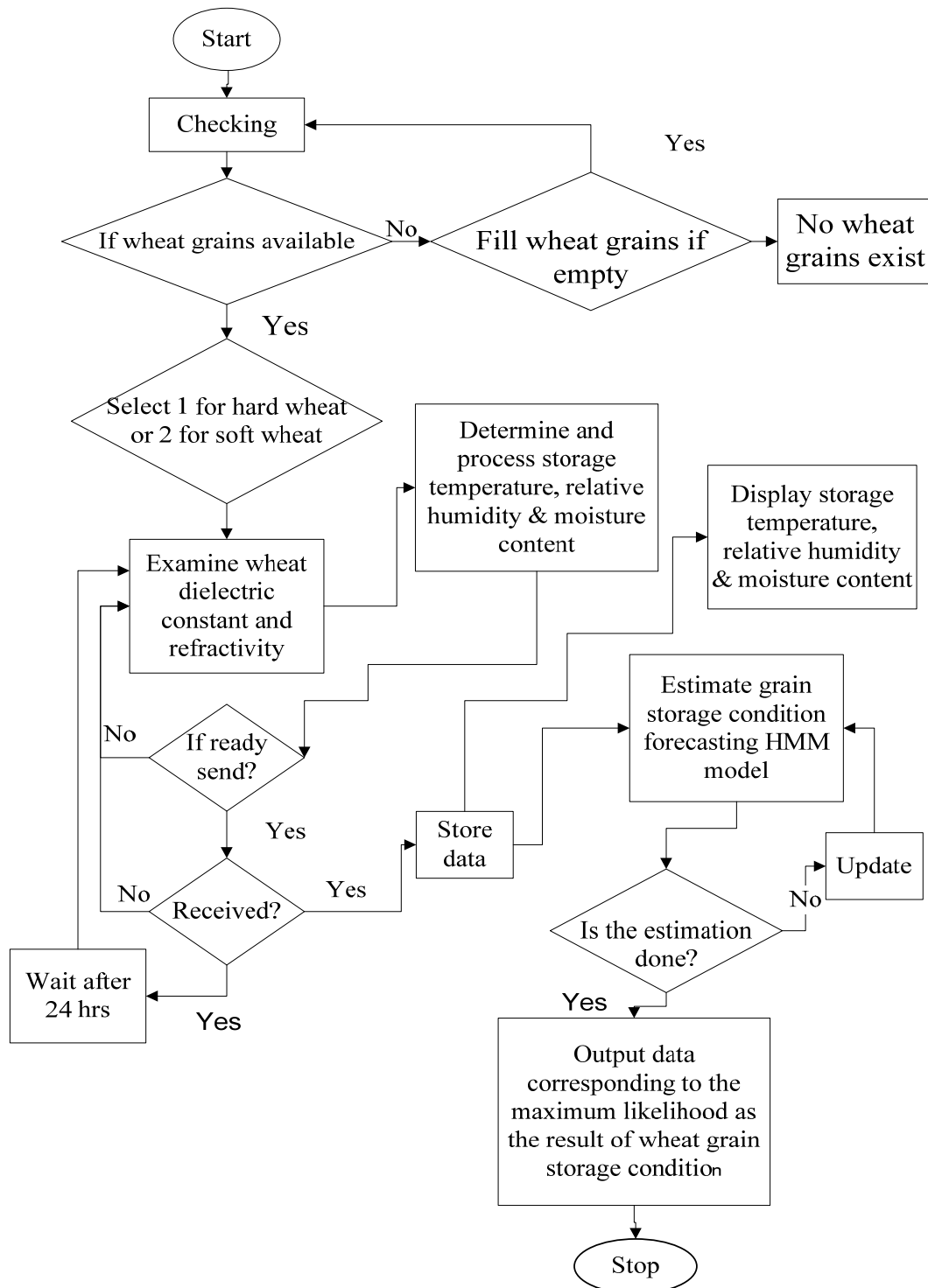

## Appendix II: Training Data for Grain Storage Condition Forecasting Method

BAKHRESA GROUP



### RECORD SHEET

Week beginning: 01/05/2015

Silo 21A / Hard White Wheat Temperature and Moisture Content  
 Temperature - T / C & Moisture Contents - MC (% dry basis)

Week No.	Monday		Tuesday		Wednesday		Thursday		Friday		Saturday		Sunday	
	T	MC	T	MC	T	MC	T	MC	T	MC	T	MC	T	MC
1									20	13	19	12.8	20	13.0
2	19	13.0	21	12.0	19	13.0	18	13.3	17	13.2	18	11.0	21	13.4
3	22	12.5	23	13.4	18	13.3	40	12.6	44	13.0	22	13.3	24	17.0
4	30	15.0	26	15.0	22	14.0	20	13.4	20	16.0	19	15.3	20	14.3
5	30	14.0	40	17.0	20	14.7	20	18.0	25	14.8				

Field student's name: Johevajile Kamala Mazima

Purpose: Research data

Approved by: Iddi Mvungi

Position: Grain milling Division Supervisor

Signature: \_\_\_\_\_

02 June 2015

## Appendix III: Sample Hard Wheat Grain Storage Condition Data in the Greenhouse

1	28/05/2017	L1	22.4	46.0	L2	21.6	47.0
2	29/05/2017	L1	22.0	47.0	L2	21.0	48.0
3	30/05/2017	L1	22.3	46.1	L2	21.5	47.0
4	31/05/2017	L1	22.1	46.3	L2	21.3	47.2
5	01/06/2017	L1	22.0	47.0	L2	21.0	48.0
6	02/06/2017	L1	22.1	46.5	L2	21.4	47.2
7	03/06/2017	L1	22.0	47.6	L2	21.0	49.0
8	04/06/2017	L1	21.4	49.5	L2	20.7	51.0
9	05/06/2017	L1	21.2	50.0	L2	20.3	51.6
10	06/06/2017	L1	21.4	49.6	L2	20.6	51.0
11	07/06/2017	L1	21.3	49.8	L2	20.4	51.0
12	08/06/2017	L1	20.7	50.6	L2	20.0	52.0
13	09/06/2017	L1	21.2	50.0	L2	20.2	51.3
14	10/06/2017	L1	21.4	49.4	L2	20.8	49.4
15	11/06/2017	L1	22.0	46.4	L2	21.2	47.2
16	12/06/2017	L1	22.3	46.2	L2	21.5	47.0
17	13/06/2017	L1	22.0	47.0	L2	21.0	49.0
18	14/06/2017	L1	22.3	46.3	L2	21.5	47.0
19	15/06/2017	L1	23.0	45.0	L2	22.0	46.6
20	16/06/2017	L1	23.1	45.0	L2	22.2	46.0
21	17/06/2017	L1	23.0	45.3	L2	22.0	46.5
22	18/06/2017	L1	23.2	45.0	L2	22.2	46.0
23	19/06/2017	L1	23.1	45.0	L2	22.0	46.5
24	20/06/2017	L1	22.5	46.0	L2	21.8	46.8
25	21/06/2017	L1	19.1	20.3	L2	21.2	21.0

## Appendix IV: Sample Soft Wheat Grain Storage Condition Data in the Greenhouse

1	04/05/2017	L1	24.0	44.2	L2	23.9	44.6
2	05/05/2017	L1	24.1	44.0	L2	23.9	44.4
3	06/05/2017	L1	22.5	46.1	L2	22.1	46.8
4	07/05/2017	L1	23.0	45.0	L2	22.6	46.0
5	08/05/2017	L1	22.6	46.1	L2	22.4	46.4
6	09/05/2017	L1	22.5	46.1	L2	22.1	46.9
7	10/05/2017	L1	21.4	49.2	L2	21.0	49.9
8	11/05/2017	L1	21.0	50.0	L2	20.8	50.3
9	12/05/2017	L1	21.5	49.0	L2	21.0	49.9
10	13/05/2017	L1	22.0	46.8	L2	21.5	49.0
11	14/05/2017	L1	22.8	46.0	L2	21.7	48.3
12	15/05/2017	L1	23.1	44.9	L2	22.8	45.8
13	16/05/2017	L1	23.5	44.5	L2	22.9	45.7
14	17/05/2017	L1	23.6	44.5	L2	22.9	45.8
15	18/05/2017	L1	24.0	44.2	L2	23.8	44.7
16	19/05/2017	L1	23.9	44.2	L2	23.6	44.8
17	20/05/2017	L1	23.7	44.3	L2	23.4	44.9
18	21/05/2017	L1	23.4	44.6	L2	22.8	45.8
19	22/05/2017	L1	23.0	45.0	L2	22.6	46.1
20	23/05/2017	L1	22.5	46.1	L2	22.3	46.7
21	24/05/2017	L1	22.2	46.3	L2	22.0	47.0
22	25/05/2017	L1	23.0	45.0	L2	22.6	46.2

## Appendix V: Data from Hard Wheat Storage Layers in the Greenhouse

```

*****Current Hard Wheat Storage Condition Data*****
Layer: L1
Temperature: 19.1 °C
Current Hidden State: Cold
Relative Humidity: 20.3%
Moisture Content: 8.46%
Current Observed State: Dry
Current Dielectric Constant: 3.5557
Refractivity: 385.6500

Layer: L2
Temperature: 21.2 °C
Current Hidden State: Warm
Relative Humidity: 21.0%
Moisture Content: 8.50%
Current Observed State: Dry
Current Dielectric Constant: 3.5579
Refractivity: 386.2329

```

## Appendix VI: Data from Soft Wheat Storage Layers in the Greenhouse

```
*****Current Soft Wheat Storage Condition Data*****  
Layer: L1  
Temperature: 23.0 °C  
Current Hidden State: Warm  
Relative Humidity: 45.0%  
Moisture Content: 11.86%  
Current Observed State: Dry  
Current Dielectric Constant: 3.7519  
Refractivity: 436.9783  
  
Layer: L2  
Temperature: 22.6 °C  
Current Hidden State: Warm  
Relative Humidity: 46.2%  
Moisture Content: 12.05%  
Current Observed State: Dry  
Current Dielectric Constant: 3.7620  
Refractivity: 439.5779
```

## Appendix VII: Forecasted Data from Hard Wheat Storage in the Greenhouse

```
-----Output For Layer 1-----  
  
Hidden states probability matrix:  
  
0.7143  0.2857  0.0000  
  
0.6667  0.3333  0.0000  
  
0.0000  0.0000  0.0000  
  
Observed states probability matrix:  
  
1.0000  0.0000  0.0000  
  
1.0000  0.0000  0.0000  
  
0.0000  0.0000  0.0000  
  
Optimal Hidden States Path: CCCWCCCCC   Sequence of Observed states : DDDWDDDDDD
```

## Appendix VIII: Forecasted Data from Soft Wheat Storage in the Greenhouse

-----Output For Layer 2-----

Hidden states probability matrix:

0.7500 0.2500 0.0000

1.0000 0.0000 0.0000

0.0000 0.0000 0.0000

Observed states probability matrix:

1.0000 0.0000 0.0000

1.0000 0.0000 0.0000

0.0000 0.0000 0.0000

Optimal Hidden States Path: WCCCCCCCC Sequence of Observed states : DWDDDDDDDD