

2015-11-11

Design of an Automated River Water Level Monitoring System by using Global System for Mobile Communications

Kato, Agrey

International Journal of Computer Science and Information Security (IJCSIS)

<http://dspace.nm-aist.ac.tz/handle/123456789/194>

Provided with love from The Nelson Mandela African Institution of Science and Technology

Design of an Automated River Water Level Monitoring System by using Global System for Mobile Communications

Agrey Kato

Electronics and Telecommunication Engineering
The Nelson African Institution of Science and Technology
Arusha, Tanzania

Ramadhan Sinda, Shubi Kaijage

Electronics and Telecommunication Engineering
The Nelson African Institution of Science and Technology
Arusha, Tanzania

Abstract – This paper proposes a wireless solution, based on Global System for Mobile Communication (GSM) network for the monitoring and controlling of the river water level parameter. One of the advantages of the system is that it can be used for monitoring decrement of water level in the rivers and water level rising in case of flooding. The system at a certain interval continuously sends river water level measurements to the concerned authority with water environmental flow management. But once the river water reaches the critical level either by decreasing or flooding, an alarm will be sent via GSM network to the personal in charge, furthermore, the proposed system allows on-line configurations of the system equipment's at the field. This system, uses open access platform Arduino as main controller, ultrasonic sensing equipment and web infrastructure that allows remote access of information from any place of the country.

Keywords: GSM, Open Access Platform Arduino and Ultrasonic Sensor.

1. INTRODUCTION

Tanzanian national water policies and laws call for protection of a reserve in all aquatic ecosystems[1],[2]. The reserve is generally defined as the minimum water levels that must be left in the system in order to sustain, as a first priority, basic human needs and aquatic ecosystems. These policies and laws recognize that healthy river systems require minimum flow levels to be sustained, but that rivers in turn provide a multitude of ecosystem services for communities, including clean drinking water, food, building materials, and religious and cultural roles.

In some cases water level monitoring is done by an individual who visits each river and takes water level samples using a method known as The Building Block Methodology (BBM). Often these rivers are in places with difficult access making the procedure difficult, expensive and results unreliable[3]. Obtaining water level measurements of the rivers manually, analysing and

making overall decisions on water control and management if needed, it is a slow and expensive task which in turn doesn't guarantee reliable results. Sampling results obtained with a big delay doesn't let doing corrections in time. Measurements of water levels in the main channels of rivers, upland tributaries and floodplain lakes are necessary for understanding flooding hazards, methane production, sediment transport and nutrient exchange. But most remote river basins have only a few gauging stations and these tend to be restricted to large river channels. Although radar remote sensing techniques using interferometric phase measurements have the potential to greatly improve spatial sampling. The technique makes use of the fact that flooded forests and floodplain lakes with emergent shrubs permit radar double-bounce returns from water and vegetation surfaces[4],[5]; thus allowing coherence to be maintained. With additional data from future satellite missions, the technique described here should provide direct observations important for understanding flood dynamics and hydrologic exchange between rivers and flood plains[6]. Space borne radar interferometric delay measurements are used to infer high-resolution maps of integrated atmospheric water vapour, which can be readily related to meteorological phenomena. Maps of the water vapour distribution associated with a precipitating cloud, partly precipitating conventional methods, and suggest that such radar observations can be used for forecasting and to study atmospheric dynamics[7-9].

However the limitations and high cost on using radar interferometry through satellite enforces researchers to come up with other different technological ways through information systems that allow remote monitoring of water level[10]. These systems are real time remote sensing of the water level parameter which provide information that enables effective monitoring and control of water usage at low cost[11-14]. Water level information is periodically transmitted to the head office and stored in a database. The systems may be equipped with the decision support algorithms and applied to identifying and controlling changes in each

river. The consultation and administration of the data is carried out through the Global System for Mobile Communications (GSM) network which is available almost all over the country. The information system allows real time monitoring and notice about some typical situations. With real time information, it is possible to prevent the supply of water while the level is at a critical point[15-19].

2. REVIEW OF THE STATE OF THE ART

Currently in our country all rivers use historical gauging stations to determine water levels of low and high flows, the measurement taken through these stations guide the specialists in prescribing reserve flow recommendations within the natural range of the river's hydrological regime and extrapolate the reserve flow recommendations across the natural shape of the river's hydrograph[20],[21]. Collecting water level measurements from these gauging stations is time consuming and expensive task which in turn doesn't assure reliable results. The designed systems by researchers facilitate human in collecting water level data that can be performed in real-time. The ultrasonic sensor is used as non-contact sensors for detecting water level by measuring distance between sensor and water surfaces[22],[23]. The sensor connected to the controller unit which reads the variable water level values and employing the Short Message Service (SMS) standard to send it by the cellular phone network. This is also accomplished by means of a GSM Modem which transmits it to the database of the concerned authority[24-26]. Most people rely on rivers not only for water, but also for a wide variety of ecosystem services, including food, medicinal herbs, building materials, and religious practices. The capacity of a river to meet these varying demands depends upon having a sufficient amount of water within its channel over time at levels that mimic the river's normal ebbs and flows. Thus, both components of the reserve such as basic human need and sustainable aquatic ecosystems benefit people directly. As human populations increase, there is increased demand for riverine resources by sometimes conflicting interests. People must decide which resources are critical enough to their livelihood that they are worth protecting. Working with local communities is the best way to determine what primary ecosystem services a river provides, to what degree those services depend on certain flow levels, and

how those services may have changed over time. The primary objectives of this paper are to 1) describe adequate provision of human needs by water resources annually and accessibility of water for domestic purposes. 2) Determine the current systems and proposed system suitability from a theoretical point of view as well as practical reasons for using it. 3) Describe the experimental design and how it accomplished the threat to the river water level.

3. PROPOSED SYSTEM OVERVIEW

The designed system use commercial hardware to allow the acquisition of river water levels from ultrasonic sensor which placed near to the river water surface. After the data acquisition, with a defined sampling period, this data is processed by Arduino and sent by GSM Modem to the database of the head office station, concerned with water environmental flow management. The responsibility for the water resource maintenance is informed every time when the minimum critical water level reached. There are several ways to get information about critical water level status. The first is from a message sent to a mobile phone, through an SMS using GSM technology, and the second through a personal in charge who can also get data in real-time by polling the desire remote system as can be seen in the block diagram in Fig. 1.

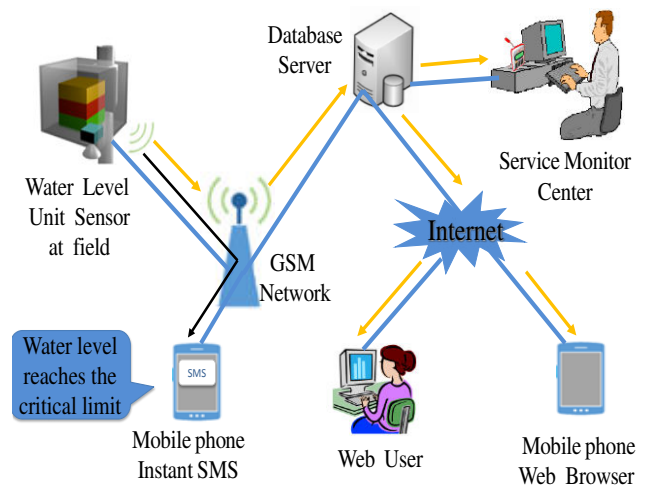

Fig 1.0: Designed System Block Diagram

To operate the designed system, interfacing and hardware configurations should be properly set to reach the desired goals. The system is divided into two constituents, field part and user part.

Field Part: To acquire data and transmitting, the following hardware are used, commercial ultrasonic level sensor is used to read the water level values and processing to the Arduino controller that commands GSM to send information to the database of the concerned authority.

User Part: River water level data gathered and sent by the GSM will be presented to the users through the web and mobile phone instant message.

4. SYSTEM DESIGN, SIMULATION AND RESULTS

The designed system is simulated by using Proteus 8 design suit software. Water level sensors will be distributed into different sites of the river, for this simulation, we have considered only one site, which is Ngara Site located at the Kagera River.

CASE 1: Water Level at Minimum Critical Point

In the design, the water level variations will be presented by auto variable voltage source which is connected to analog pin of ultrasonic sensor, and the Arduino will read the value received from the sensor, displayed on the Liquid Crystal Display (LCD) then sends the measurements to the central office for decision making through GSM Modem. Depending on the value of the water level, the LCD and GSM are processing the actual values. The minimum critical point in this simulation was set to all levels less than six metres. For instance if the water level decreases to the critical point the Arduino controller commands the GSM to send an alarm to an authority concern with environmental flow assessment. For the simulation purpose, an alarm is represented by the Light Emitting Diode (LED): Say, if the level drops to the critical point then the LED will switch ON for two minutes. The setup for an automated River Water Level Monitoring System based on Global System for Mobile Communication network when water level decreases up to the minimum critical point (< 6m) is shown in Fig. 2.

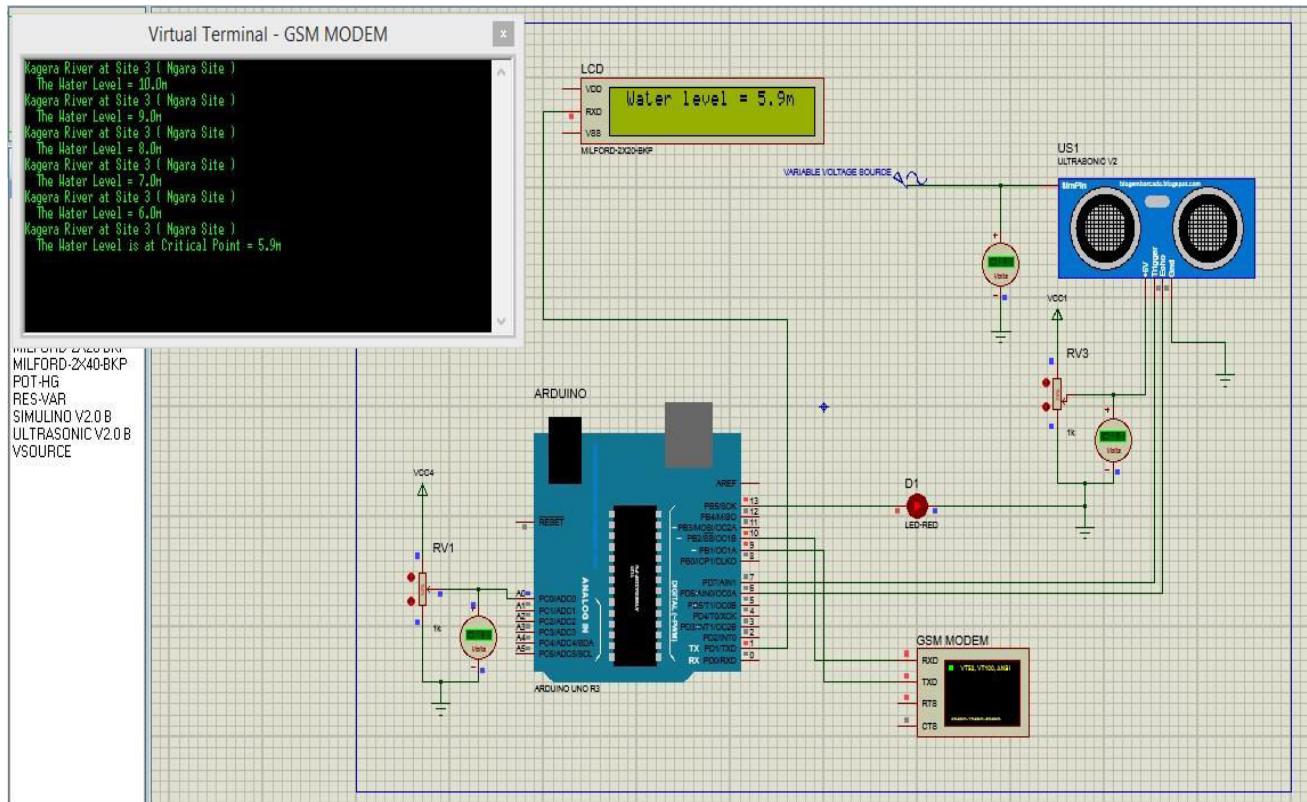

Fig. 2.0 Data Transmission Model between Ultrasonic Sensor, Arduino, Liquid Crystal Display and GSM Modem During water level decreasing to minimum critical point

CASE 2: Water Level at Maximum to Flooding Point

The flooding point in this simulation was set to all levels greater or equal 12m then the LCD will display the actual value while the Arduino is responsible for commanding the GSM to send information to the control unit on the water level status. If the water level $\geq 12\text{m}$, the LED is lighting, that is an alarm implying that the water level is about flooding so as measures should be taken. In the design, the water level of the river is varied through auto variable voltage source which is connected to analog pin of ultrasonic sensor. The Arduino part reads the signal value received from the sensor, displaying on the LCD then sends the

measurements to the master unit for decision making through GSM Modem. Regarding the real value of the water level, the LCD and GSM will be processing the actual values. Now if the water levels continue rising to the maximum point the Arduino controller will also continue to command the GSM to send an alarm to an authority concern with environmental flow assessment. For the simulation purpose, an alarm is represented by the LED. The setup for simulation of an automated River Water Level Monitoring System, based on GSM network when water level increasing up to the maximum point ($\geq 12\text{m}$) is shown in Fig. 3.

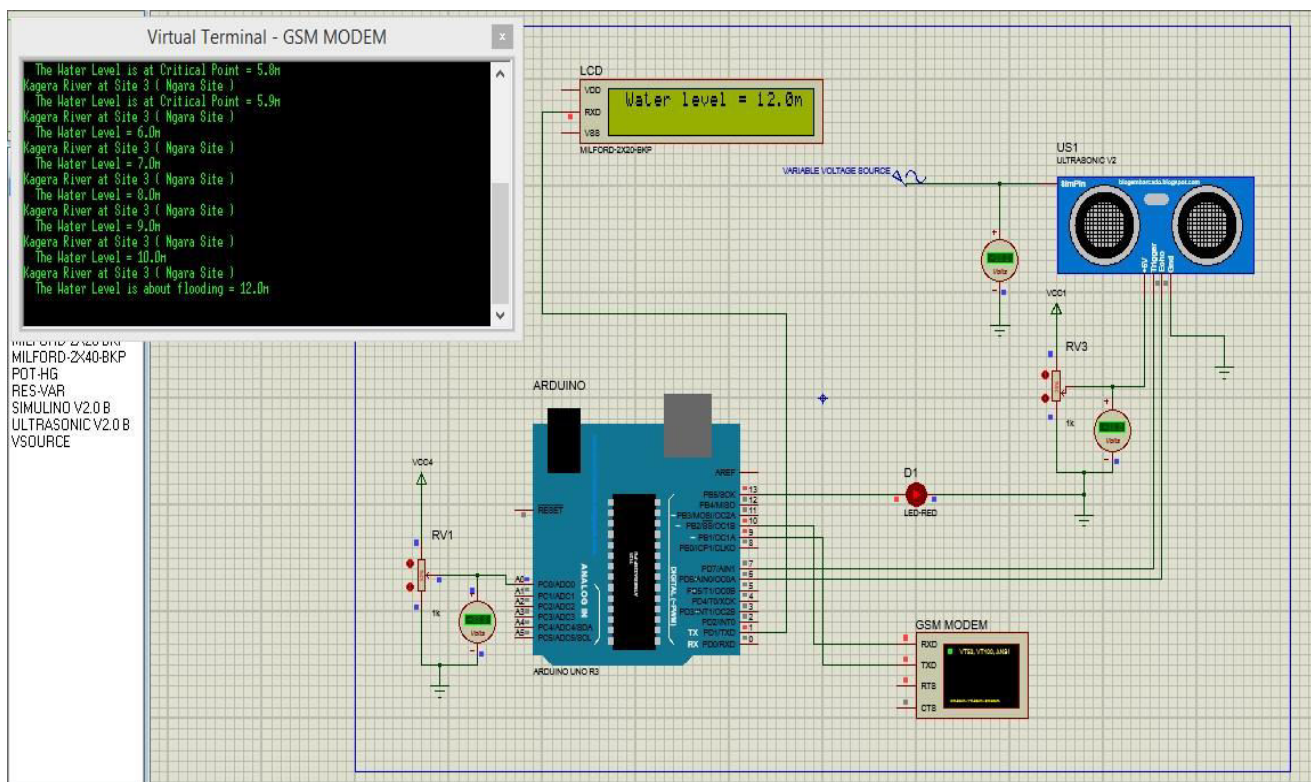

Fig. 3.0 Data Transmission Model between Ultrasonic Sensor, Arduino, Liquid Crystal Display and GSM Modem During water level increasing to flooding point

System Performance Requirements

Remote configuration: It should be possible to configure some parameters of the system remotely.
Event notification: The system has to allow notification in real-time if disruptive events occur.
Update Information: The system must allow new inquiry in order to attain current data.
Monitoring water level status: Monitoring the supplied water brings two major benefits, namely real-time analysis of the water level parameter and using the data to produce statistical reports.

User Requirements

Performance: The system has to be more accurate in measuring processing through ultrasonic sensor.
Flexibility: The system must be flexible in order to allow the user to insert, remove or edit parameters.
Usability: A friendly interface, flexible, with strong graphical capabilities, succinct and clear messages.
Power supply: In order to solve the problem of remote areas located in isolated places, with difficult access, and without power supply, the system needs to be equipped with a solar panel and a battery.

5. DISCUSSION

As the world's water resources become increasingly stressed, effective systems for management become more important. Several river water levels measuring systems for providing real time measurements to the concerned authorities with environmental flows assessment are available but most of them are relatively expensive. Therefore this paper presents the low cost river water level detection system to help the concerned authorities on getting river water level real-data. For an effective river water level control, detailed information must be available about the water level of the river. There is certainly a lack of available low cost systems for monitoring river water level to help during rain and dry season to estimate the required level to be left in the river for ecosystem survival. At the same time, control strategies have to be further developed to enable an effective management of the river water resource. A number of concepts for river water level detection systems have been introduced during the last decade and have been proven mainly by simulation studies. It is obvious that real time water level measurements in rivers environments like getting water level status and taking measures is still a challenging task which needs researchers to work hard so as to attain the solutions. According to the kind of river water level system used in our country "gauging stations" considerable innovations like the one presented by this paper are needed. Given the problems associated with the river water level, it is clear that delay in getting water level information could lead to the serious disaster. It is therefore of paramount importance that river water level assessment tools should be also developed and become an integrated part of operational control systems. Together with such tool, more advanced measurement system that can deliver key variables as certain water level parameters, will become acceptable for practical implementation and will deliver a boost in performance of the river water level control system.

6. CONCLUSION AND FUTURE WORK

The paper presented a proposed system with the aim of providing real-time river water level monitoring and warning response. The system employs the use of ultrasonic sensor, Arduino controller and GSM network in performing real-time monitoring of water information. The designed water level monitoring system is composed of three major components: 1) water level sensor, 2) processing and transmitting modules, and 3) database and application server. The connectivity is done through the GSM network. The ultrasonic sensor measures water level related data while the processing and transmission module is used to transmit measured data to the database and application server. The database and application server is implemented as a web-based application to allow users to view real-time water-related data as well as historical data. The designed system is also able to send warnings to the responsible authorities in case of emergency. It is evident that using this type of proposed system will have potential advantages in terms of time and cost saving. Through this system one can use it to indicate accessible and inaccessible roads to help commuters during critical scenarios. Our future work is to implement an automated river water level monitoring system by using the GSM networks and test in the real environment and evaluates its performance.

7. ACKNOWLEDGEMENTS

The authors gratefully acknowledge the support of the Nelson Mandela African Institute of Science and Technology under the department of Electronics and Telecommunication Engineering for the funding and numerous supports that has been put together to complete this vital system design.

REFERENCES

- [1] U. R. o. Tanzania, "The Water Policy. Government Printer, Dodoma, Tanzania," ed, 2002.
- [2] U. R. o. Tanzania, "The Water Resource Management Act. Government Printer, Dodoma, Tanzania", 2009.
- [3] J. King, *et al.*, "Environmental Flow Assessments For Rivers: Manual For The Building Block Methodology". *Printed in the Republic of South Africa*, August 2008.
- [4] D. E. Alsdorf, *et al.*, "Amazon floodplain water level changes measured with interferometric SIR-C radar," *Geoscience and Remote Sensing, IEEE Transactions on*, vol. 39, pp. 423-431, 2001.
- [5] D. Perissin and T. Wang, "Repeat-pass SAR interferometry with partially coherent targets," *Geoscience and Remote Sensing, IEEE Transactions on*, vol. 50, pp. 271-280, 2012.
- [6] T. Dunne, *et al.*, "Exchanges of sediment between the flood plain and channel of the Amazon River in Brazil," *Geological Society of America Bulletin*, vol. 110, pp. 450-467, 1998.
- [7] R. F. Hanssen, *et al.*, "High-resolution water vapor mapping from interferometric radar measurements," *Science*, vol. 283, pp. 1297-1299, 1999.
- [8] S. Jin, *et al.*, "Observing and understanding the Earth system variations from space geodesy," *Journal of Geodynamics*, vol. 72, pp. 1-10, 2013.
- [9] J. Hu, *et al.*, "Resolving three-dimensional surface displacements from InSAR measurements: A review," *Earth-Science Reviews*, vol. 133, pp. 1-17, 2014.
- [10] Wikipedia. (2015). *Interferometric synthetic aperture radar*.
- [11] G. Schumann, *et al.*, "Conditioning water stages from satellite imagery on uncertain data points," *Geoscience and Remote Sensing Letters, IEEE*, vol. 5, pp. 810-813, 2008.
- [12] G. Schumann and G. Di Baldassarre, "The direct use of radar satellites for event-specific flood risk mapping," *Remote Sensing Letters*, vol. 1, pp. 75-84, 2010.
- [13] J. K. Levy, *et al.*, "Advances in decision support systems for flood disaster management: Challenges and opportunities," *Water Resources Development*, vol. 21, pp. 593-612, 2005.
- [14] G. Schumann, *et al.*, "Progress in integration of remote sensing-derived flood extent and stage data and hydraulic models," *Reviews of Geophysics*, vol. 47, 2009.
- [15] F. R. Ribeiro, *et al.*, "Water supply remote monitoring system: a case study," 2004.
- [16] F. M. n. de Santa Olalla, *et al.*, "Monitoring irrigation water use by combining Irrigation Advisory Service, and remotely sensed data with a geographic information system," *Agricultural water management*, vol. 61, pp. 111-124, 2003.
- [17] Y. Chemin, *et al.*, "Using remote sensing data for water depletion assessment at administrative and irrigation-system levels: case study of the Ferghana Province of Uzbekistan," *Agricultural Water Management*, vol. 64, pp. 183-196, 2004.
- [18] H. B. Glasgow, *et al.*, "Real-time remote monitoring of water quality: a review of current applications, and advancements in sensor, telemetry, and computing technologies," *Journal of Experimental Marine Biology and Ecology*, vol. 300, pp. 409-448, 2004.
- [19] W. S. Khawaja and L. Xinhai, "Utilization of Telecom Technologies for the Disaster Management in Underdeveloped Coastal Districts of Pakistan," *International Journal of Academic Research in Business and Social Sciences*, vol. 3, pp. 197-213, 2013.
- [20] M. E. McClain, *et al.*, "Comparing flow regime, channel hydraulics, and biological communities to infer flow-ecology relationships in the Mara River of Kenya and Tanzania," *Hydrological Sciences Journal*, vol. 59, pp. 801-819, 2014.
- [21] P. M. Ndomba, "Streamflow Data Needs for Water Resources Management and Monitoring Challenges: A Case Study of Wami River Subbasin in Tanzania," in *Nile River Basin*, ed: Springer, 2014, pp. 23-49.
- [22] L. C. Lynnworth, "Ultrasonic measurements for process control: theory, techniques, applications": Academic press, 2013.
- [23] O. Korostynska, *et al.*, "Monitoring pollutants in wastewater: traditional lab based versus modern real-time approaches," in *Smart Sensors for Real-Time Water Quality Monitoring*, ed: Springer, 2013, pp. 1-24.
- [24] I. Priyadarshinee, *et al.*, "Flood Prediction and Prevention through Wireless Sensor Networking (WSN): A Survey," *International Journal of Computer Applications*, vol. 113, 2015.
- [25] C. Scholpp, "Method and system for remote monitoring of fluid quality and treatment," ed: Google Patents, 2010.
- [26] M. S. Tampke, "Monitoring and alarming system and method," ed: Google Patents, 2010.