

2021-11

Automatic Railway Road Crossing (RLC) Traffic Light System for Metric Gauge Railway Network in Tanzania

NKUNZIMANA, Libere

International Journal of Advances in Scientific Research and Engineering (ijasre)

[https://doi.org/ 10.31695/IJASRE.2021.34099](https://doi.org/10.31695/IJASRE.2021.34099)

Provided with love from The Nelson Mandela African Institution of Science and Technology

Automatic Railway Road Crossing (RLC) Traffic Light System for Metric Gauge Railway Network in Tanzania

Libere NKUNZIMANA¹, Gilbert Minja¹, Christina Mariki¹, Innocent Zirakwiye¹, Neema Mduma²,
Mussa Ally Dida³

Scholar¹, Lecturer², Senior Lecturer³

School of Computational and Communication Sciences and Engineering

Nelson Mandela African Institution of Science and Technology

Arusha-Tanzania

ABSTRACT

The verdict has been established that Railway Level Crossings (RLCs) present a possible risk to roads users. Because of the ever-increasing number of vehicles on the road every day, it was determined that employing automation at level crossings can be beneficial to both road and railway users' safety. The aim is to develop an automated railway level crossing system that would reduce the likelihood of collisions between trains and road users at intersections. From the perspective of a railway level crossing, the conditions safeguards must meet is straightforward - Before a train passes, there must be a complete stop for all road users. Two RFID sensors and Ultrasonic sensors are used located at strike-in and strike-out points at the level crossing. Detection of automobiles stuck on the rail road once the train has activated the automation at the RLC is performed by the Ultrasonic sensor. Other warning measures in the system include an automated barrier, Light Emitting Diode flashing lights, and an audio alarm device. Arduino UNO and ESP32 were used as microcontrollers to perform all the logical operations and control commands. Consequently, the next train station from RLC was updated of the incoming train's Expected Time of Arrival (ETA). The time it takes for the barriers to close will be determined by the train's speed. In this project work, the prospective application strategy for securing rail road crossings are described in detail. It is the best feasible control of the level crossing by using the train detection system.

Key words: Railway Level Crossing, RFID sensor, Ultrasonic sensor, Microcontroller, Strike-in point, Strike-out point.

1. INTRODUCTION

1.1 Background of the study

Tanzania railway network spans a total of 2701 Kilometers. From 2000 to 2012, Railway Police Stations have recorded 434 accidents and 197 deaths in Morogoro, Dodoma and Tabora alone (Trc, 2021). The Historical backdrop of railway road crossing level relies upon the area; however, early railway road crossings had a flagman in a nearby booth who would, on the approach of a train, wave a red flag or a lantern to stop all traffic using the road and clear the tracks at the respective intersections (Al-Zuhairi, 2013). Gated crossings became commonplace in many areas, as they protected the railway from people trespassing and livestock, and they protected the users of the crossing when closed by the signalman/gateman. In the second quarter of the twentieth century, manual or electrical closable gates that blocked the roadway began to be implemented, with the goal of providing a full barrier against any road traffic entering the railway (Al-Zuhairi, 2013).

There had been a significant decrease in the number of railway accidents since the introduction of automated gated systems at the level crossings. As a result, more researchers have been enthused to explore more on system designs that will lower the numbers (Adha et al., 2018). There are a variety of reasons why train accidents occur in most of which take place at crossings when automobiles (or other road users) attempt to outrun the train. When such mishaps happen, they often involve the passengers, driver, and some passersby.

In a railway level crossing collision occurrence, regardless of who caused it - the road vehicle or the train – it is the car's driver's life that is jeopardized; moreover, only she/he has the ability to prevent the accident from occurring. As a result, road users are obliged to not only follow traffic laws, but also to double-check their vehicles at the crossing, even if the lights indicate 'Go'. Rail Level Crossings (RLC) are points where rail and road traffic flows meet. Given their continued density in traditional high-speed railway networks across the world, RLCs are a neuralgic point of the railway system, both in terms of traffic safety and operation (Reddy et al., 2017). For these reasons, level crossings should be investigated individually since they are a major source of railway accidents, and all railway companies should have a system to manage the degree of safety offered to its customers. The phrase 'RLC management' refers to the whole process/methodology that a railway infrastructure manager must adhere to during the design, building, operation, and maintenance of RLCs, aiming at:

- Keeping the possibility of an accident at RLCs to a bare minimum;
- Ensuring that trains pass through the RLC site at the necessary speed;
- Maintaining the RLC's operational and equipment maintenance costs at tolerable levels.

The importance of RLCs monitoring and Control is to alert people or road users that there is a train which is approaching and actuating the gate to block the load using automatic gates and traffic lights in order to avoid accidents (Salmon et al., 2018). Automation involving sensors and actuators coupled with microcontrollers as the computing engine for the RLC operation. In-hand with the use of ICT building blocks such as Data Transmission mechanism/technology, Information storage (On-premise/Cloud-based), the unmanned operation of the RLC are efficiently achieved (Cho and Jung, 2010).

Presently, the Information and Communication Technologies (ICT) have been developed, and it plays a vital role in the transportation system. In the transport companies, ICT is used for communication, to improve safety, to provide access to travel information, to design and develop automatic systems. There is significant proof that Information Communication Technologies have deeply changed the ways in which transport systems are used, such that ICT provides possibilities to reduce jams and congestion. Train to vehicle and train to infrastructures communication can be controlled by using integration of multiple technologies (Anila et al., 2017).

An automatic Railway Level Crossing Traffic Light System based of ultrasonic and RFID has been proposed and developed to overcome the aforementioned challenges. This system would help to reduce destruction of property, trains and the railways; Avoid deaths caused by accidents at railway level crossing; Raise awareness to the community about railway level crossing safety; Automated operation prevents errors from manual operation; There will be no human resource required, this makes the running cost very low compared to manned gates.

2. RELATED WORKS

The need for an automated system in Tanzania has been attracting the attention of scholars for the past few years after the revamp of Railway transportation. Railways are often regarded as one of the most cost-effective and secure means of transportation in the world. Engineers and researchers from all around the world are attempting to build intelligently managed railway level crossing gate control systems (Moorthy et al., 2020).

Rayi and Naveen (2018) Pointed out that, about 43.6% of railway accidents occurred at level crossings in India. To accommodate for the challenges, they proposed an innovative approach for Indian Railways with the manually controlled level crossing gates by a Gate keeper. By the use of an InfraRed (IR) sensor and a warning signal at level crossings, the suggested technology automatically selects whether to open or shut the level crossing barrier based on the arrival or departure of the train at the level crossing. However, when there is a minor change in external temperature or deposition of dust on the sensor mirror, the usage of IR sensors has restrictions on time responsiveness in detection and poor detection capabilities.

In India, an intelligent controller for unmanned railway gate control systems was developed. This system used 89C52 Microcontroller and reed sensors together to avoid railway accidents at level crossing. The sensor detects the arrival and the departure of the train and the obstacles between the gates using DC motors. This work also proposes the detection of obstacles between the gates at the time of train arrival using IR, LED and oscillator circuits (Soppimath and Hudedmani). However, because the RLC operation is a life-critical operation, quick responses are essential. In compared to commonly accessible microcontrollers such as Arduino, the 89C52 Microcontrollers had a limited resolution (8-bit) and sluggish speeds in reacting to sensory stimuli from the IR sensors. Furthermore, the system used infrared sensors, which have a very short reaction time and are greatly affected by temperature and dust.

In Sudan, a certain outcome of incidents has been observed, death and injuries at the level of the road crossing railways, had proposed an automatic alarm and control system that forces traffic to stop while the train is crossing the roof using steel storage

edges to close and open the gate. They proposed to use a microcontroller, the hydraulic system and the use of sensors allowing fast operations and whilst saving time, but this was deemed costly in the end for a mass installation across the entire rail network.

With an ever-increasing population, the railway sector is always plagued by technological and human mistakes putting aside cases of suicide or suspected suicide especially at railway level crossings hence, on a daily basis, such junctions need continual human coordination and supervision. Accidents/collisions at railway-road crossings are recorded almost every year (Anila et al., 2017).

3. MATERIALS AND METHODS

3.1. Case of study

The study was conducted in the United Republic of Tanzania especially in Arusha region. The study focused on the RLC close to the Nelson Mandela African Institute of Science and Technology (NM-AIST) at the CHEKERENI suburb also considering the other areas such as Dodoma and Dar es Salaam. According to Trc (2021), the train rail roads are abundant in those cities where at least 2 to 3 trains pass in the city per day, 4-6 trains pass in Dodoma per day and 6-8 trains pass in Dar es Salaam per day.

3.2. Project Design Approach

To develop and design this system the AGILE System development method which design and prototyping processes involve three phases, namely Conceptual Creation and Requirements analysis, System design and development and finally system testing and performance validation (Bello and Steiner, 2019) was adopted. The Conceptual Creation phase required an understanding of the RLC operation, current practices and tools available for analysis. The performance validation phase involves computation of the design and system refinement process. A refinement of the model is necessary to ensure the model would be functioning effectively based on requirements. This process will be repeated until the performance measure is satisfied. The design needs to be implemented and evaluated; therefore, real life cases could be used to calibrate the system.

The prototype developed, this involved all parts and process in implementing the concept based on the design. Arduino UNO board (*figure 2(a)*) and ESP32 were deployed as microcontroller boards and where the codes were housed, RFID Assembly for both sides of the sensing part, proximity sensors for detection of the train approaching the RLC, Servo-motors for the automated gates and LEDs for signaling.

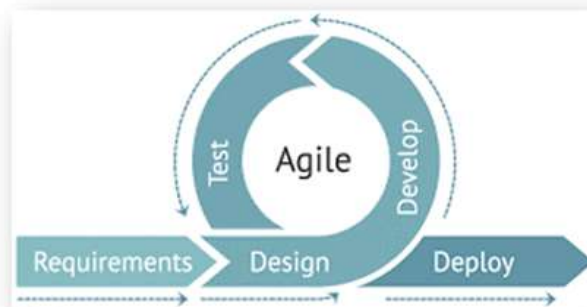

Figure 1: Agile System Development

3.3 System requirements

During the development of this system, the following system requirements classified in two categories such as software and hardware requirements have been used.

3.3.1 Software tools used

- a) **Arduino IDE:** Arduino Integrated Development Environment (IDE) is open-source text editor software used for programming Microcontrollers. Arduino IDE is both hardware and software. Arduino projects began in 2005 with students of Institute Ivrea in Ivrea-Italy, intended to present the interaction of sensors and actuators within the environment at simple technique and low cost (Fezari & Al Dahoud, 2018).
- b) **Fritzing software:** Huge open-source tool used for designing an electronic circuit for specific purpose such automatic railway road-crossing traffic light. It is for prototyping and designing electronic projects. With Fritzing, you can connect Sensors and actuators, writing codes and running in order to get result (Knörig et al., 2009).

3.3.2. Hardware tools used

a) **Arduino UNO:** The Arduino Uno (figure 2(a)) is a microcontroller board based on the Atmega328. Arduino UNO microcontroller is used to screen the status of all the level crossing related devices. This microcontroller is the brain or the core of this prototype design where all codes from RFID, Ultrasonic sensor, Servo motor, LEDs and Buzzer are configured allow the communication between the sensing part and the actuation (Adha et al., 2018). Arduino UNO micro-controller is used to screen the status of all the level crossing related devices such as RFID reader, flashing lights and mechanical barriers triggering, audible alarm activation, and also manual control of gate mechanism in case of emergency.



Figure 2: (a) Arduino UNO R3 Board (b) RFID tag and reader

b) **RFID reader and RFID Tag:** RFID is an acronym for “radio-frequency identification” and refers to a technology whereby digital data encoded in RFID tags or smart labels. The use of RFID detection equipped with radio frequency sensors plays a significant role in modern industries worldwide including railway industry. They are trustworthy and fairly cheap based on choice of detection based signaling applications as for the level crossing protection system (Ji et al., 2018). The RFID system functions by detecting the presence of an approaching train from either direction of the RLC. The system encompasses an RFID Reader near the railway track and an RFID tag which is installed in a train carriage. Together with the RFID system (figure 2(b)), a microcontroller is installed in a control box along the track line. The microcontrollers generate signal controls based on the detection of availability of a train and notify whether there is an incoming train.

Why RFID in this project

The RFID technology is based on radio frequency data transmission. It has been considered to be used in this project for the following reasons

- ✓ Reliable and cost-effective basis for a range of detection applications;
 - ✓ Easy to integrate into a wide range of rail profiles;
 - ✓ RFID is based on a unique User Identification (UID) which enables detection of a designated train approaching and not otherwise;
 - ✓ Low power consumption ranging from 5 VDC to 30 VDC depending on the RFID type deployed;
 - ✓ Installation is simple and system easily maintainable;
- Scalability, offers room for more developments and add-on services (logistic management).

c) **Ultrasonic Sensor:** Ultrasonic sensors (figure 3(a)) work by sending out a sound wave at a frequency above the range of human hearing. The sensor determines the distance to a target by measuring time lapses between the sending and receiving of the ultrasonic pulse. In this prototype design, the ultrasonic sensor has the same task as the RFID technology but as a backup technology to allow accurate monitoring of the train’s speed and the continuous changing distance between the train and the railway road crossing level as the train approaches the junction.

d) **Servo Motor** A servomotor (figure 3(b)) is a rotary actuator or linear actuator that allows for precise control of angular or linear position, velocity and acceleration. In this prototype, the servo motor enables the activity of closing and opening of the barrier gate.



(a)



(b)

Figure 3: (a) Ultrasonic sensor module (b) The Servo Motor

- e) **Audible alarm warning (Buzzer):** This is an audible warning equipment/component deployed together with other active control devices. It necessary to warn motorists, bicyclists and pedestrians of the approaching train at the intersection. The alarm is activated when the warning light begin to flash. The alarm should go off when the automatic gates ascend up clearing way for the road traffic (Reddy et al., 2017).

- f) **Red and white stripped boom gate with traffic lights:** Flash lights at level crossing have one red lights, a green light. The two red light flash alternately at the rate 45 – 60 times in a minute. They vary in design and usually pointed to the road users. They are accompanied by cross buck mounted on the same pole on top of the lights. Traffic lights (LED) are necessary to give active visual warning to the road users. If there is no train approaching, the active warnings should remain off, road users have a right of way according to the green light. LEDs signal should be of a long service life but yet require less maintenance. On the description of their high contrast, they shine brighter and more clearly than conventional signal transmitters and are clearly visible even in direct sunlight. Nowadays, the malfunctions of LED status can be checked and detected via current monitoring using current sensors. In the case of our design, we chose to use green light which signals the road users of a clear RLC (Salmon et al., 2015).



Figure 4: Red and white stripped boom gate with traffic lights

3.4. Description of the developed Automatic RLC

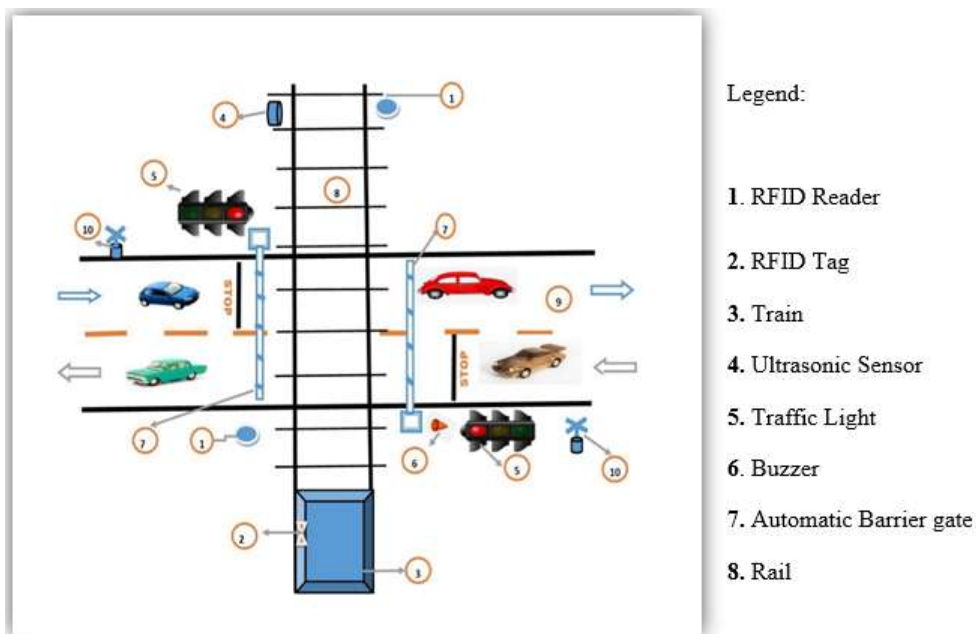

Figure 5: Design of an Automatic RLC

3.5. Data Flow Diagram

This represented the events flow of inputs and output information in our central control unit.

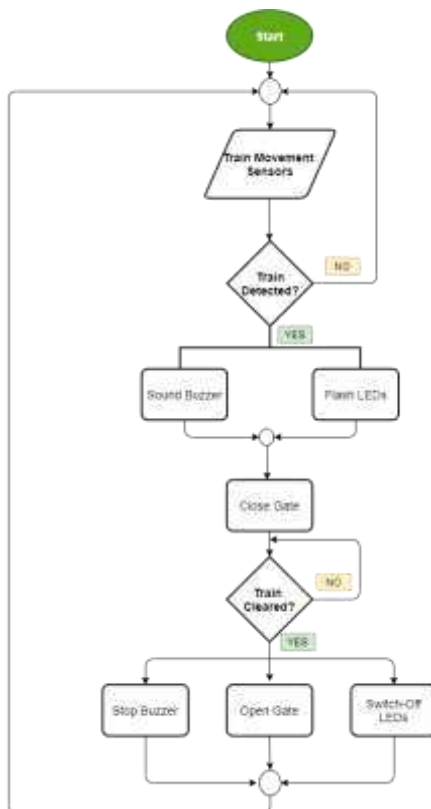

Figure 6: The flow of events and controls for the RLC system designed

3.6. Circuit Diagram Design

This schematic diagram represented the connectivity of all components of the system designed at the control unit.

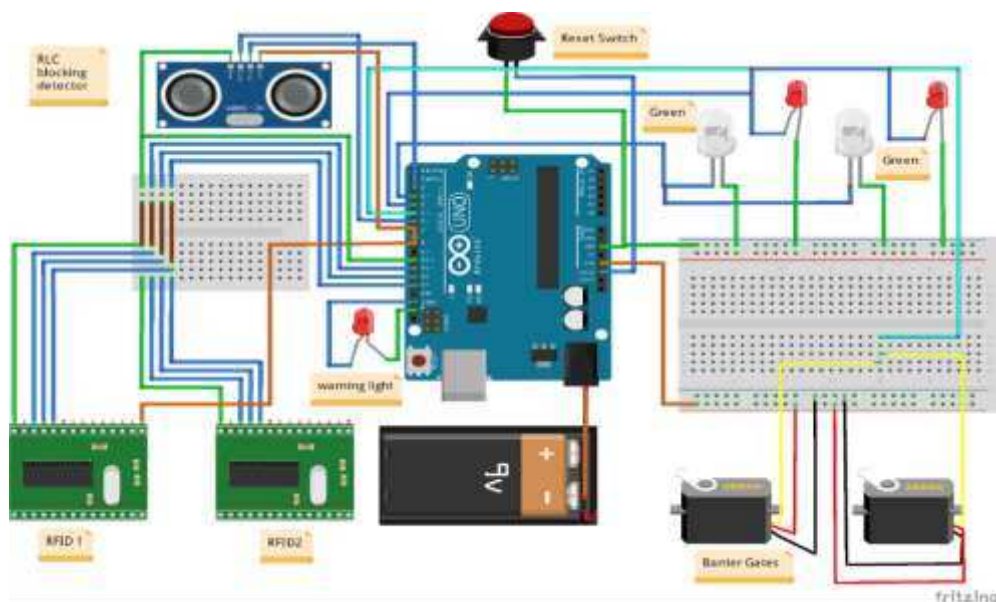

Figure 7: The Schematic diagram for the RLC design

4. DISCUSSION AND RESULTS

Each level crossing protection system has its own types and variants of technical design. Each country has its own specific design, standards and safety requirements as far as level crossing protection system is concerned. Each designer for level crossing protection offers different technical solution according to the standards for being either local or regional. As flexible, accessible and combined components of level crossing protection system, RFID technology offer enormous benefits that will satisfy a series of safety requirements and operational conditions. Railway Road Level Crossing is a system designed and developed to reduce accidents at the Railway Road Crossing level.

This system will assist automobile drivers and pedestrians in recognizing an oncoming train, and the gate will automatically close or open the road barriers to allow the train to pass without colliding with the vehicles. RFID MFRC522 reader sensor and RFID tags attached to the rail side and the train carriage are used for train detection to activate and deactivate the level-crossing system. The ultrasonic sensors are used for the obstacle detection at the level crossing protection systems and control. Furthermore, regardless of the speed the train is operating on the track, the circuits controlling the automatic warning devices provide a minimum operation of 30 seconds before the train arrive at the level crossing. Basically, this automatic railway level crossing system consists of 4 main parts; sensing, transmitting, processing and controlling.

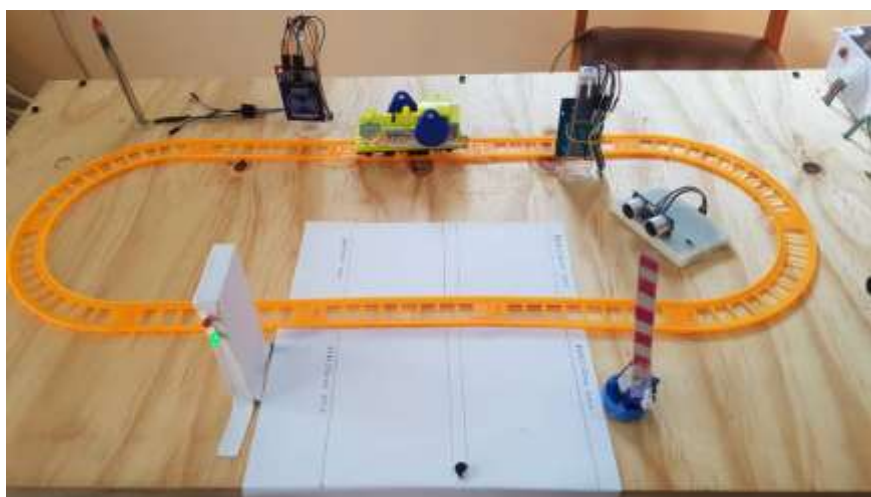

Figure 8: The developed prototype for the RLC

5. CONCLUSION

The automatic railway level crossing system was created with the goal of minimizing accidents at level crossings worldwide. Without active warning measures such as mechanical barriers, flashing lights, and alarms, level crossings pose a risk to both train and road traffic. Automation of barrier gate shutting and opening utilizing RFID and ultrasonic sensors will decrease accidents to a larger extent. At the same time, it may not always be possible or essential to eliminate a railroad crossing via costly grade separation in order to improve rail and road safety. The proposed system is cost-effective, convenient, efficient, secure and tailor-made level crossing protection system that is best suited to be implemented in the future of railway industry.

REFERENCES

1. Adha, F. R., Yusro, M. & Yuliatmojo, P. J. J. P. V. T. E. (2018). SISTEM LAMPU SEIN MATI OTOMATIS, DETEKSI TITIK BUTA PENGENDARA, DAN ENGINE STOP BERBASIS ARDUINO PADA SEPEDA MOTOR. 1, 18-21.
2. Al-Zuhairi, A. S. M. (2013). Automatic railway gate and crossing control based sensors & microcontroller. *International Journal of Computer Trends and Technology (IJCTT)*, 4, 2135-2140.
3. Anila, S., Saranya, B., Kiruthikamani, G. & Devi, P. (2017). Intelligent system for automatic railway gate controlling and obstacle detection. *International Journal Of Current Engineering And Scientific Research (IJCESR)*, 4, 2394-0697.
4. Bello, L. L. & Steiner, W. J. P. O. T. I. (2019). A perspective on IEEE time-sensitive networking for industrial communication and automation systems. 107, 1094-1120.
5. Cho, B.-K. & Jung, J.-I. (2010). A Study on Intelligent Railway Level Crossing System for Accident Prevention. *International Journal of Railway*, 3, 106-112.
6. Ji, W., Li, L. & Zhou, W. (2018). Design and implementation of a RFID reader/router in RFID-WSN hybrid system. *Future Internet*, 10, 106.
7. Moorthy, P., Vishnupriya, P., Poornima, N., Priyadarshini, R. & Kharche, S. (2020). Automatic Railway Level Crossing Using LoRa.
8. Rayi, C. S. & Naveen, C. (2018). Object's Action Detection using GMM Algorithm for Smart Visual Surveillance System. *Procedia computer science*, 133, 276-283.
9. Reddy, E. A., Kavati, I., Rao, K. S. & Kumar, G. K. (2017). A secure railway crossing system using IOT. International conference of Electronics, Communication and Aerospace Technology (ICECA), 2017. IEEE, 196-199.
10. Salmon, P. M., Lenné, M. G., Read, G. J., Mulvihill, C. M., Cornelissen, M., Young, K. L., Walker, G. H., Stanton, N. A. & Stevens, N. (2015). Beyond the crossing: a cognitive work analysis of rail level crossing systems. *Procedia Manufacturing*, 3, 2921-2928.
11. Salmon, P. M., Read, G. J., Walker, G. H., Goode, N., Grant, E., Dallat, C., Carden, T., Naweed, A. & Stanton, N. A. (2018). STAMP goes EAST: Integrating systems ergonomics methods for the analysis of railway level crossing safety management. *Safety science*, 110, 31-46.
12. Soppimath, V. M. & Hudedmani, M. AN INTELLIGENT CONTROLLER FOR UNMANNED RAILWAY GATE CONTROL SYSTEMS.
13. Trc. 2021. *Railway Network* [Online]. TRC. Available: <https://www.trc.co.tz/> (Accessed 20/12/2020 2021).

AUTHORS' PROFILE



Libere NKUNZIMANA born at Gitunga-Kayokwe commune, Mwaro province of Burundi. He is a Msc candidate in Embedded and Mobile System, specializing in Embedded System at Nelson Mandela African Institution of Sciences and Technology. He has a background in telecommunications engineering and management obtained at Hope Africa University in Bujumbura Burundi. He is an assistant Lecture at Hope Africa University, Funder of Burundian Cohort of Technology Company, Worked at Lacell SU and Lumitel Ltd. His interests lie in Electronics security, Information Communication and Technology of development in educational sector, Health and internet governance. Email: liberen@nm-aist.ac.tz



Gilbert MINJA born in Mwanza, Tanzania. He is an MSc candidate in Embedded and Mobile System, specializing in Embedded Systems at The Nelson Mandela African Institution of Sciences and Technology. He has a background in Electronics and Telecommunications Engineering obtained at The University of Dar es Salaam in Tanzania. His interests lie in the fields of Renewable Energies and control systems for solar business systems and productive use machinery automation respectively advocating Sustainable Development Goals (SDGs). Email: minjag@nm-aist.ac.tz, gkitau@gmail.com



Christina Wilfred Mariki born in Arusha – Tanzania. Pursuing a master’s degree in Embedded and Mobile Systems, specializing in Embedded System at Nelson Mandela African Institution of Science and Technology. I have a professional experience and an academic background in Computer Science and statistics from the University of Dar es salaam in Tanzania, I have Worked for Joint Malaria Program under Good Samaritan Foundation- Kilimanjaro Christian Medical Center for IMPROVE Project study (Improving Pregnancy Outcome with intermittent Preventive treatment in Africa) and Cardio safety study, Clinical Trials based in Handeni District- Tanga- Tanzania. My interest lies in ICT for maternal health and ICT in Transportation infrastructures. Email: marikic@nm-aist.ac.tz , chriswilmariki@gmail.com



Innocent ZIRAKWIYE born at Nyange-Musanze District, Northern Province of Rwanda. He is an MSc candidate in Embedded and Mobile System, specializing in Embedded System at Nelson Mandela African Institution of Sciences and Technology. He has a background in Computer Science obtained at the National University of Rwanda in Huye Rwanda., Worked at Ministry of Education Rwanda (Ecole Secondaire Saint Joseph Karuganda). His interest lies in ICT for Transportation, Drones for Agriculture and ICT for Health. Email: zirakwiyei@nm-aist.ac.tz



Dr. Neema Mduma is lecturer the Nelson Mandela African Institution of Science and Technology (NM-AIST) in Tanzania. She has PhD and MSc in Information and Communication Sciences and Engineering from NM-AIST in 2020 and 2016 respectively. Neema is passionate about education particularly girls, and during her PhD, she developed a Machine Learning model called BakiShule which aimed at preventing students from dropping out of school. Neema’s efforts towards women in science has been recognized and she was given an award from the L’Oréal UNESCO as 20 young talents in Sub-Saharan Africa for the year 2020. Her research interests are Artificial Intelligence, Machine Learning and Data Science. Email: neema.mduma@nm-aist.ac.tz .



Dr. Mussa Ally Dida is a Senior Lecturer at NM-AIST School of Computational and Communication Sciences and Engineering (CoCSE), Deputy Centre Leader of the Centre of Excellence for ICT in East Africa (CENIT@EA). He has a PhD in Information and Communication Engineering from Beijing Institute of Technology (BIT), China attained in June 2017. He has supervised/ co-supervised 14 Masters and 2 PhD students to graduation and he is currently supervising more than 10 masters and PhD students. He has published more than 40 papers in highly reputable journals. His research interests are in the areas of wireless communication systems, embedded systems, and IT systems development. Email: mussa.ally@nm-aist.ac.tz.