

2021-10

# Development of a sensor based heartbeat rate and body temperature monitoring system for remote chronic patients

Obira, Okello

NM-AIST

---

<https://doi.org/10.58694/20.500.12479/1605>

*Provided with love from The Nelson Mandela African Institution of Science and Technology*

**DEVELOPMENT OF A SENSOR BASED HEARTBEAT RATE AND BODY  
TEMPERATURE MONITORING SYSTEM FOR REMOTE CHRONIC  
PATIENTS**

**Okello Jimmy Obira**

**A Project Report Submitted in Partial Fulfilment of the Requirements for the Degree of  
Master of Science in Embedded and Mobile Systems of the Nelson Mandela African  
Institution of Science and Technology**

**Arusha, Tanzania**

**October, 2021**

## **ABSTRACT**

The growing number of chronic diseases have stretched the health sector. Globally, over 36 million deaths per year are attributed to chronic diseases. This has increased the demand for telemedicine in managing chronic patients. The involvement of wireless sensor networks and cloud computing in the health sector is increasing due to the potential it possesses in remote monitoring applications. This project presents a developed system prototype for monitoring heartbeat and temperature of chronic patients using sensors. The monitored data is relayed to the cloud database in real time via internet connection using ESP8266 module. The approach involves connecting a heartbeat sensor, an MLX90614 contactless temperature sensor, LCD and an ESP8266 module to the Arduino board. The aim of this project was to create a system that relays chronic patient's body temperature and heartbeat readings to medical personnel in an attempt to avert the effects of fewer health facilities in rural areas. The patient's data in the cloud database can be retrieved by medical doctors anytime in order to track the patient's condition. The sensed heartbeat and body temperature readings were processed, sent and received in the cloud database effectively. The readings were also displayed on the LCD for the patients to see. The developed system successfully fills the gap in providing doctors access to the patient's data in a timely manner. It was concluded that sensor networks are effective in remote monitoring of the patient's temperature and heartbeat readings and the data can be successfully sent to the cloud database.

## DECLARATION

I, **Okello Jimmy Obira** do hereby declare to the Senate of the Nelson Mandela African Institution of Science and Technology that this project report is my original work and it has not been submitted for degree award in this institution or any other institution.

  
.....


**Signature**

05/11/2021  
.....

**Date**

The above declaration is confirmed

**Dr. Sam Anael**

  
.....

**Signature**

**Supervisor One**

15<sup>th</sup> Nov 2021  
.....

**Date**

**Dr. Ramadhani Sindi**

  
.....

**Signature**

**Supervisor Two**

15-11-2021  
.....

**Date**

## **COPYRIGHT**

This report is copyright material protected under the Berne Convention, the Copyright Act of 1999 and other international and national enactments, in that behalf, on intellectual property. It must not be reproduced by any means, in full or in part, except for short extracts in fair dealing; for researcher, private study, critical scholarly review or discourse with an acknowledgement, without a written permission of the Deputy Vice Chancellor for Academic, Research and Innovation, on behalf of both the author and the Nelson Mandela African Institution of Science and Technology.

## CERTIFICATION

The undersigned certify that they have read and hereby recommend for acceptance by the Nelson Mandela African Institution of Science and Technology a project report entitled, “**Development of a Sensor Based Heartbeat Rate and Body Temperature Monitoring System for Remote Chronic Patients**” submitted in partial fulfilment of the requirements for the degree of Master of Science in Embedded and Mobile Systems of the Nelson Mandela African Institution of Science and Technology.

**Dr. Sam Anael**

.....  
*Sam Anael*

**Signature**

**Supervisor One**

.....  
*15th Nov 2021*

**Date**

**Dr. Ramadhani Sindi**

.....  
*Ramadhani Sindi*

**Signature**

**Supervisor Two**

.....  
*15-11-2021*

**Date**

## **ACKNOWLEDGEMENTS**

Firstly, I gratify Almighty God for providing the ability and strength to have this project successful.

Secondly, I express my gratitude to the supervisors Dr. Sam Anael and Dr. Ramadhani Sinde for their guidance, support and advice throughout my project work and report writing.

Thirdly, I thank all the staffs and students of the Nelson Mandela African Institution of Science and Technology for the various input toward this project work.

Lastly, I extend my special thanks to the sponsors, Center of Excellence for ICT in East Africa for the financial support that made this project a success.

## **DEDICATION**

This project work is dedicated to my parents and family for the emotional support. Lastly, I dedicate this report work to the supervisors and the sponsors CENIT@EA for the financial support that made this work a success.



## TABLE OF CONTENTS

ABSTRACT.....	i
DECLARATION .....	ii
COPYRIGHT .....	iii
CERTIFICATION .....	iv
ACKNOWLEDGEMENTS.....	v
DEDICATION.....	vi
TABLE OF CONTENTS.....	vii
LIST OF TABLES.....	x
LIST OF FIGURES .....	xi
LIST OF APPENDICES.....	xii
LIST OF ABBREVIATIONS AND SYMBOLS .....	xiii
CHAPTER ONE.....	1
INTRODUCTION .....	1
1.1 Background of the Problem.....	1
1.2 Statement of the Problem .....	2
1.3 Rationale of the Project.....	2
1.4 Objectives.....	3
1.4.1 Main Objectives.....	3
1.4.2 Specific Objectives .....	3
1.5 Research Questions .....	3
1.6 Significance of the Project .....	3
1.7 Delineation of the Project.....	4
CHAPTER TWO .....	5

LITERATURE REVIEW .....	5
2.1 Introduction .....	5
2.2 Internet Use in Uganda.....	5
2.3 Literature Review on Telemedicine .....	5
2.3 Literature Review on Remote Patient Monitoring .....	6
2.4 Related Works .....	6
2.5 Importance of Real Time Patient Monitoring Systems.....	8
2.6 The Proposed System for Remote Patient Monitoring.....	9
CHAPTER THREE .....	11
MATERIALS AND METHODS.....	11
3.1 Introduction .....	11
3.2 Project Design .....	11
3.2.1 Target Population .....	11
3.2.2 Sample Size and Sampling Technique .....	11
3.2.3 Data Collection.....	11
3.3 Developed Heartbeat and Body Temperature Monitoring System .....	12
3.4 Hardware Requirements.....	13
3.4.1 Arduino UNO .....	13
3.4.2 Heartbeat Sensor.....	14
3.4.3 MLX90614 Contactless Temperature Sensor .....	15
3.4.4 ESP8266 Wireless Module.....	16
3.4.5 Liquid Crystal Display .....	17
3.4.6 Potentiometer.....	18
3.5 Integrated Development Environment for Arduino .....	19
3.6 ThingSpeak IOT Cloud Database .....	19

CHAPTER FOUR.....	21
RESULTS AND DISCUSSION.....	21
4.1 Introduction.....	21
4.2 Results on Liquid Crystal Display .....	21
4.3 ThingSpeak Online Cloud Service.....	21
4.4 Validation.....	24
4.4.1 Unit Test.....	25
4.4.2 Integration Test.....	26
4.4.3 System Test .....	26
CHAPTER FIVE .....	27
CONCLUSION AND RECOMMENDATIONS .....	27
5.1 Conclusion.....	27
5.2 Recommendations .....	27
REFERENCES .....	29
APPENDICES .....	32
RESEARCH OUTPUTS.....	49

## LIST OF TABLES

Table 1:	Project Requirements .....	13
Table 2:	System Testing Results .....	25

## LIST OF FIGURES

Figure 1:	System Overview.....	10
Figure 2:	Block Diagram of the Developed System.....	12
Figure 3:	Arduino Hardware.....	14
Figure 4:	Heartbeat Sensor.....	15
Figure 5:	MLX90614 Contactless Temperature Sensor.....	16
Figure 6:	ESP8266 Wireless Module.....	17
Figure 7:	Liquid Crystal Display.....	18
Figure 8:	Potentiometer.....	19
Figure 9:	ThingSpeak Capture of Body Temperature Readings.....	22
Figure 10:	ThingSpeak Capture of Heartbeat Readings.....	23
Figure 11:	Comparison of Temperature Readings.....	24
Figure 12:	Comparison of Heartbeat Readings.....	24

## LIST OF APPENDICES

Appendix 1:	Codes for Heartbeat Sensor Interfacing with Arduino Nodes.....	32
Appendix 2:	Codes for Temperature Sensor Interfacing with Arduino Nodes.....	34
Appendix 3:	Codes for the Complete Developed System.....	36
Appendix 4:	Snapshot of the Developed System.....	40
Appendix 5:	Snapshot of the Heartbeat Measurement.....	41
Appendix 6:	Snapshot of the Body Temperature Measurement .....	42
Appendix 7:	Temperature Readings Comparison .....	43
Appendix 8:	Comparison of Heartbeat Readings.....	46

## LIST OF ABBREVIATIONS AND SYMBOLS

NCDs	Non Communicable Diseases
CDs	Communicable Diseases
TMCG	The Medical Concierge Group
LCD	Liquid Crystal Display
GSM	Global System for Mobile Communication
3G	Third Generation
LTE	Long Term Evolution
4G	Fourth Generation
UCC	Uganda Communications Commission
ICT	Information and Communication Technology
PWM	Pulse Width Modulation
IR	Infrared
LED	Light Emitting Diode
SMS	Short Message Service
ALC	Ambient Light Cancellation
FIFO	First in First Out
ADC	Analog Digital Converter
IoT	Internet of Things
ISP	Internet Service Provider
HTTP	Hyper Text Transfer Protocol
BPM	Beats Per Minute
GPIO	General Purpose Input Output
EMR	Electronic Medical Record

# CHAPTER ONE

## INTRODUCTION

### 1.1 Background of the Problem

A chronic disease is basically any condition that persists for a year or more requiring continuous medical care which may curtail an individual's daily activities (National Center for Chronic Disease Prevention and Health Promotion, 2019). Some of the examples of chronic diseases include stroke, diabetes, heart disease, cancer and chronic respiratory diseases. There are other conditions such as seeing impairment, hearing impairment and genetic disorders that also account for a substantial percentage of the world disease burden.

Eighty percent of the world's deaths from chronic diseases occur in low and middle-income countries (National Center for Chronic Disease Prevention and Health Promotion, 2019). Chronic diseases pose a serious economic burden, to the individual, family and the economy. Although, currently the biggest economic burden from chronic diseases falls on the developed countries, the burden on low and less-developed countries is increasing with population growth (Nugent *et al.*, 2012). The prevalence of chronic disease is 37.9% for high income countries and 29.7% in low- and middle-income countries ((IHME), 2017) .

The management of all chronic diseases (CDs) is done over a long duration of time and also requires a multidisciplinary approach and inputs from different teams of healthcare providers (Beran, 2012).

Non-communicable chronic diseases (NCDs) especially heart diseases, hypertension, diabetes, cancers and chronic respiratory diseases are the biggest causes of deaths. Globally, over 36 million deaths occur every year from NCDs (*The Uganda NCD Alliance Strategic Plan, 2019*). Six out of ten adults in the United States of America (USA) have a chronic disease (National Center for Chronic Disease Prevention and Health Promotion, 2019).

Medical professionals use body temperature, heartbeat rate, blood pressure and pulse rate for the tracking of a patient's health condition. Body temperature and heartbeat rate are the two main



parameters checked whenever patients arrive in the hospital (Parihar *et al.*, 2017). Body temperature is one of main indicators of normal or abnormal body conditions and health.

## **1.2 Statement of the Problem**

The management of chronic diseases has become one of the biggest challenges that health sector faces world over. Currently, health sector is struggling to meet the demands of patients living with chronic diseases as they need continuous monitoring for a long time (Beran, 2012). These patients require a multidimensional approach, where the family and community is involved since most of these patients are managed outside the health facilities (Beran, 2012).

Chronic patients require continuous monitoring of their body parameters, record keeping, and informing the doctors in case of any abnormality. This is sometimes a manual process and requires proper record keeping which is still a challenge as the doctors do not receive the data in real time for immediate response while sometimes the records are lost by patients.

Taking into consideration the challenges of the monitoring, record keeping and real time transfer of patient's data, it becomes extremely paramount to develop a system that monitors and relays chronic patient's data in real time. Therefore, the system aims to address the challenges of monitoring, record keeping and timely transfer of patient's data.

## **1.3 Rationale of the Project**

This is the age of digital communication where data and information sharing are very vital for different sectors. In the health sector, patient's data and records are very important in the management of patients, it is even more paramount in chronic patients. The project aims at improving record keeping, and timely transfer of patient's data to the database. The devices used in this project are low power consumers and can be battery powered making it possible to be used in rural areas. The project also uses cheap sensors and wireless protocols to develop the monitoring system which significantly brings down the cost in comparison with the existing monitoring system. The developed system is capable of monitoring and relaying the patient's data to the cloud database in real time.

## **1.4 Objectives**

### **1.4.1 Main Objectives**

The main objective of this project was to develop a system that uses sensors to detect chronic patient's body temperature and heartbeat readings, relaying the readings to the cloud database in real time.

### **1.4.2 Specific Objectives**

- i. To review existing systems used in chronic patient's management at the medical concierge group (TMCG) Uganda.
- ii. To design a system that monitors patient's heartbeat rate and body temperature using sensors and sends the data to cloud database in real time.
- iii. To develop and test the system with diabetic and hypertensive patients of TMCG to validate the usability and efficiency.

## **1.5 Research Questions**

- i. How are the chronic patient's records managed in TMCG Uganda?
- ii. How can the design of a sensor based system that monitors heartbeat and body temperature for chronic patients be realized?
- iii. How to develop and test a sensor based system that monitors heartbeat and body temperature of chronic patients?

## **1.6 Significance of the Project**

This project is significant due to its practical contribution to the health care sector in terms of suggesting a new managing approach to chronic patients. The theoretical contributions of this project is the identification of the different ways that the health sector in Uganda is using in the management of chronic patients and their records. The project developed a system that is capable of monitoring and relaying the patient's data to the cloud database in real time. The project involved the use of sensors and wireless protocols to develop the monitoring system which significantly improve chronic patient management.

## **1.7 Delineation of the Project**

This project considered only the ways chronic patient's records are kept in relation to patients in Uganda. The project focused mostly on how TMCG Uganda manages patients on their chronic management plans. The study leading to this project did not exclusively consider how practices used elsewhere especially in Europe, Asia and United States of America. Additionally, the project did not consider developing a mobile application due to limited time that was available although, the mobile application platform would add more value to the project.

## CHAPTER TWO

### LITERATURE REVIEW

#### 2.1 Introduction

This chapter aims to introduce the context in which this project was undertaken through a review of relevant available literature. As mentioned in the previous chapter, this project proposed the development of a sensor-based heartbeat rate and body temperature monitoring system for remote chronic patients.

In order to set the foundation of the project topic, it was necessary to examine the key literature related to internet use in Uganda, telemedicine, review literature on the chronic patient management systems, remote patient monitoring and identify the gaps.

#### 2.2 Internet Use in Uganda

There is an increase in the number of internet users in Uganda due to the increasing telecommunications infrastructural development in the country. Broadband coverage in Uganda is still minimal, even compared to many other least developed African countries, with 65% coverage of third generation (3G) and only 17 percent coverage by long term evolution/fourth generation (LTE/4G) (Alison *et al.*, 2019). The estimated number of internet users in Uganda stands at 12.1 million which is 26.2% internet penetration. According to the Uganda Communications Commission (UCC), the number of internet users in Uganda increased by 1.5 million (+14%) between 2020 and 2021. However, challenges still exist in the ICT sector in Uganda. However, with the recognition of ICT by the government of Uganda as a critical means of delivering it's national Vision 2040 (Blind & Peri, 2006) a lot is expected to change in the area of internet penetration.

#### 2.3 Literature Review on Telemedicine

Tele-healthcare is basically the use of information technology in providing healthcare services to patients who are a distance away from the doctors (Sherin *et al.*, 2012). It includes the services ranging from primary health care like basic teleconsultation's services to the highly specialized

care found in leading medical centers and hospitals. The integration of wireless communications and wearable sensors in the field of medicine has facilitated and promoted telemedicine.

The use of sensor technology in clinical applications are rapidly expanding since technology companies are getting more involved in healthcare services through partnerships with healthcare providers with the aim of assisting patients and clinicians make better decisions. A system that uses Bluetooth module, sensors for accurate glucose monitoring of diabetic patients has been proposed (Sensors & Forever, 2020).

### **2.3 Literature Review on Remote Patient Monitoring**

In this project work, some previous related works on remote patient management and monitoring was studied and analyzed to appreciate the trends and also identify their gaps. These included the following:

The system that deploy wireless technology to achieve patient monitoring system have been developed. This system detects abnormalities in the patient bio signal and sends an SMS alert to medical personnel using GSM technology (Madhu, 2017).

An android-based remote patient monitoring system was developed with focus in monitoring body temperature of patients and displaying the information on a mobile application (Mouzam *et al.*, 2018).

A system that involves electrical signals to monitor heart disease has been developed. However, this system comes with a bulky strap that must be put around one's chest making it somehow uncomfortable (Mallick & Patro, 2016).

### **2.4 Related Works**

Due to the current development in embedded systems and sensor networks, the trend in the patient monitoring and management system is shifting towards remote systems commonly referred to as telemedicine.

In the last decade, there have been rapid growth in the use of low cost wireless communication protocols and sensors in the health sector and this has greatly addressed the challenges of fewer healthcare facilities (Priyanka *et al.*, 2015).

A system that uses multiple sensors for collecting data, virtual software instruments for data processing and Bluetooth for wireless data transmission has been proposed. However, this is intended to work for handheld meter reading and industrial real time data collection (Jadhav & Tadwalkar, 2015). Also an Arduino based monitoring system which is connected to the laptop and uses Bluetooth to transfer the data of heart rate and body temperature of the patients has been proposed (Yassin *et al.*, 2019). However, the patient's data is manually logged into Microsoft excel to be able to virtualize the reading on the graph.

The ARM cortex M3 LPC1768 development board is used to develop most embedded system applications due to the advantages like low power consumption and availability of several peripheral options (Jadhav & Tadwalkar, 2015). However, this is a complicated board which requires special skills and is more expensive compared to Arduino boards.

A mobile application based on android for remote patient monitoring system was developed and it focuses in monitoring the body temperature of patients and displaying the data on a mobile application (Mouzam *et al.*, 2018). However, this does not cater for users of other mobile phones that use different operating systems.

A system that involves electrical signals to monitor heart disease was developed. However, the this system comes with a bulky strap that must be put around one's chest making it a bit uncomfortable (Mallick & Patro, 2016).

A GSM based system that monitors the patient's health condition and passes messages to the doctor's mobile phones has been developed (Srinivasan *et al.*, 2020). However, GSM technology is becoming obsolete in most countries rendering the system almost obsolete.

An Arduino based system which monitor temperature and pulse rate, sending the data wirelessly by using nRF transmitter to the remote nRF receiver has been proposed (Parihar *et al.*, 2017). However, this system only displays the data on a LCD screen and does not have means of virtualizing the data for easy analysis.

A raspberry Pi based system that automatically monitors patient's heartbeat rate, body temperature, respiration rate and body movements has been developed (Prabha, 2018). However, raspberry is an expensive and complex board to program and use, making it a costly approach.

Some research works have been done in this area of patient's remote monitoring using sensors, mobile and wireless communication, especially in areas of military and industrial automation. Some of the works carried out in remote patient condition monitoring involve the use of expensive systems such as drones to capture data. However, little attention has been put on utilizing low cost ESP8266 wireless protocol, MLX90614 contactless temperature sensor and heartbeat sensors in patient remote monitoring, use of cloud database for proper record keeping and reporting.

The present work brings in the element of using a MLX90614 contactless temperature sensor and cloud database where the readings are detected by the sensors and sent to the cloud database using ESP8266 wireless module. The developed system prototype monitors body temperature and heartbeat rate readings using sensors and sends the data to the cloud database via the wireless module. These readings are permanently kept in the cloud database and anytime can be retrieved if there is need. The devices used for this system are cheap and simple to use making the developed system is cheaper and less complex as compared to other proposed systems. The main contribution of the developed system, is bridging the health access gap amongst the rural patients by providing a platform that interfaces patients and doctors. The system allows real time transmission of a patient's data to the database thus allowing quick and easy response from the doctors. The developed system provides a real-time interface between chronic patients and medical personnel which will minimize the effects of poor health facilities in areas such as the rural Africa.

## **2.5 Importance of Real Time Patient Monitoring Systems**

The growing number of chronic disease cases due to life styles and environmental factors has stretched the health care sector. This has increased the demand for telemedicine in managing chronic patients as they must be on continuous monitoring by doctors. Therefore, the application of sensor based solution to improved remote patient monitoring and reporting mechanism to doctors are paramount.

## **2.6 The Proposed System for Remote Patient Monitoring**

In the developed system, first, the user will be required to enroll their details with TMCG Uganda database. The system uses simple heartbeat sensors and MLX90614 contactless body temperature sensors, Arduino boards development board, liquid crystal display (LCD), ESP8266 wireless modules to measure and send the monitored data to cloud database. The data from the cloud database can be visited by the doctors anytime to track the history data for the registered patient. The patient monitored data that are falling outside the normal ranges will help the doctor to respond swiftly to the patient's condition. The Arduino board was considered for this project because of its advantages of availability, simplicity, low power consumption and lower cost. The developed system overview is shown in Fig. 1.



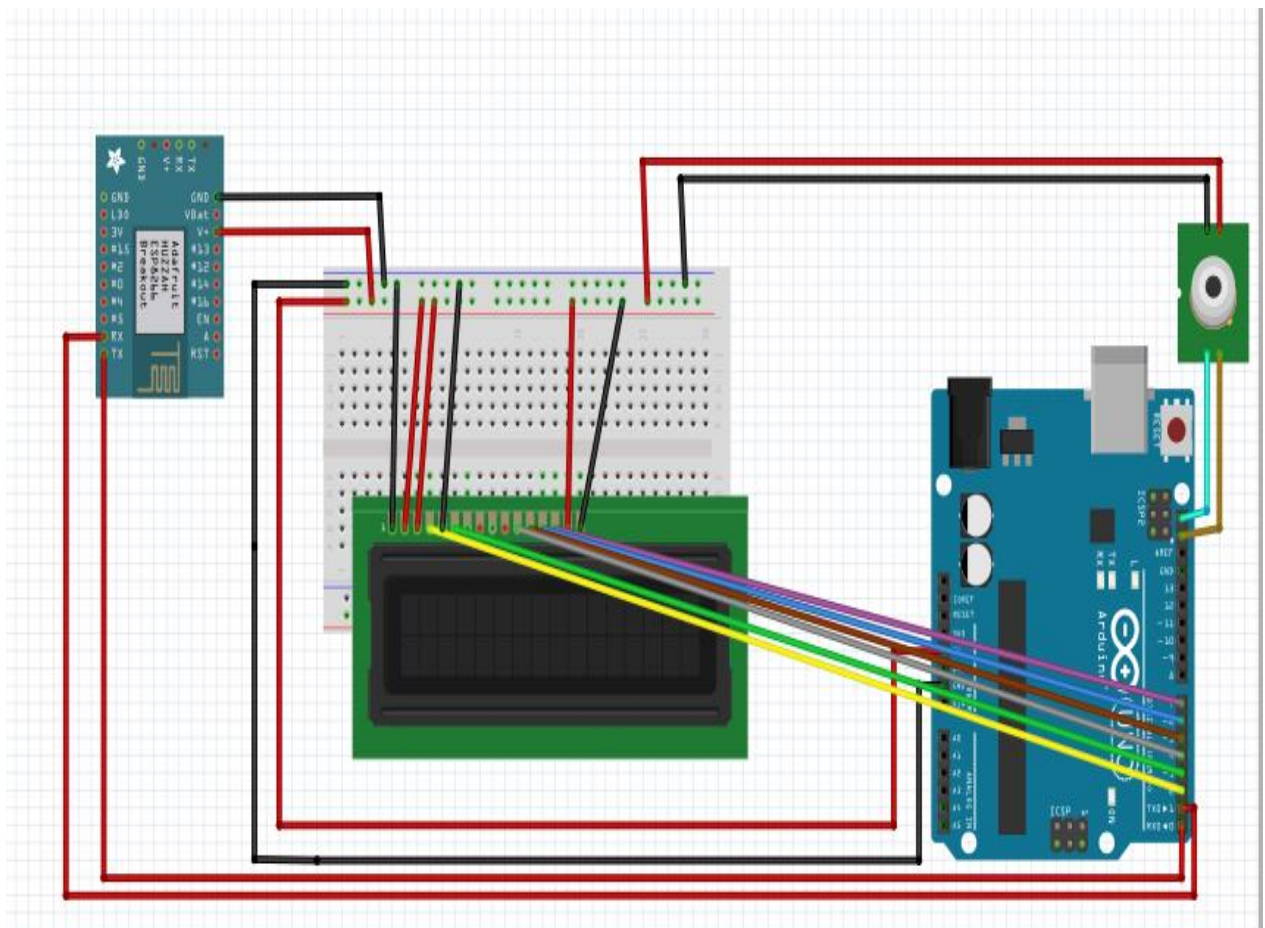


Figure 1: System Overview

## **CHAPTER THREE**

### **MATERIALS AND METHODS**

#### **3.1 Introduction**

This project methodology is a roadmap that was followed to realize the goal of the project. The project developed a system that answered the specific objectives by carrying out a number of sub-activities which was implemented sequentially as they are interrelated.

#### **3.2 Project Design**

The project deployed the heartbeat and body temperature sensors, Arduino development board and ESP8266 wireless modules. The project design was aimed at developing a sensor based heartbeat and body temperature monitoring systems for chronic patients. The following aspects formed plan of project implementation:

##### **3.2.1 Target Population**

The population targeted for the project were chronic patients subscribed to TMCG Uganda chronic patient management plan, and insurance patients. The targeted population of the project were specific to the chronic cases in Uganda.

##### **3.2.2 Sample Size and Sampling Technique**

The sample size for the project was determined using TMCG medical department algorithm based on their patient's medical records. This is an in-house algorithm developed to calculate the sample sizes. The algorithm requires inputs for population size, confidence level and the margin of error accepted in order to calculate the ideal sample size. For this project, population size was 500, confidence level of 90%, margin of error 9%, resulting into a sample size of 70. The sampling technique for this project was based on random sampling from the TMCG medical database.

##### **3.2.3 Data Collection**

Primary qualitative data was obtained from the registered insurance patients and TMCG Uganda medical plan subscribers databases and quantitative data was obtained from technical staffs and

doctors through a question and answer sessions. This was aimed at understanding and identifying the key challenges facing chronic patients in Uganda and those enrolled at TMCG.

### 3.3 Developed Heartbeat and Body Temperature Monitoring System

The developed system uses Arduino development board, heartbeat sensor and MLX90614 contactless temperature sensors, ESP8266 wireless module and IOT cloud database. The sensors which collect health indicator parameters data from the chronic patient and transmit it to the ThingSpeak IOT cloud database using ESP8266 wireless module. The data from the cloud database can be retrieved any time by the doctors. The heartbeat sensor was connected to pin A0 of the Arduino UNO while the MLX90614 contactless temperature sensor SDA and SCL was connected to the analog SDA and SCL pins respectively. Arduino UNO communicate to the ThingSpeak database remotely over a wireless protocol. The block diagram of the developed system is shown in Fig. 2.

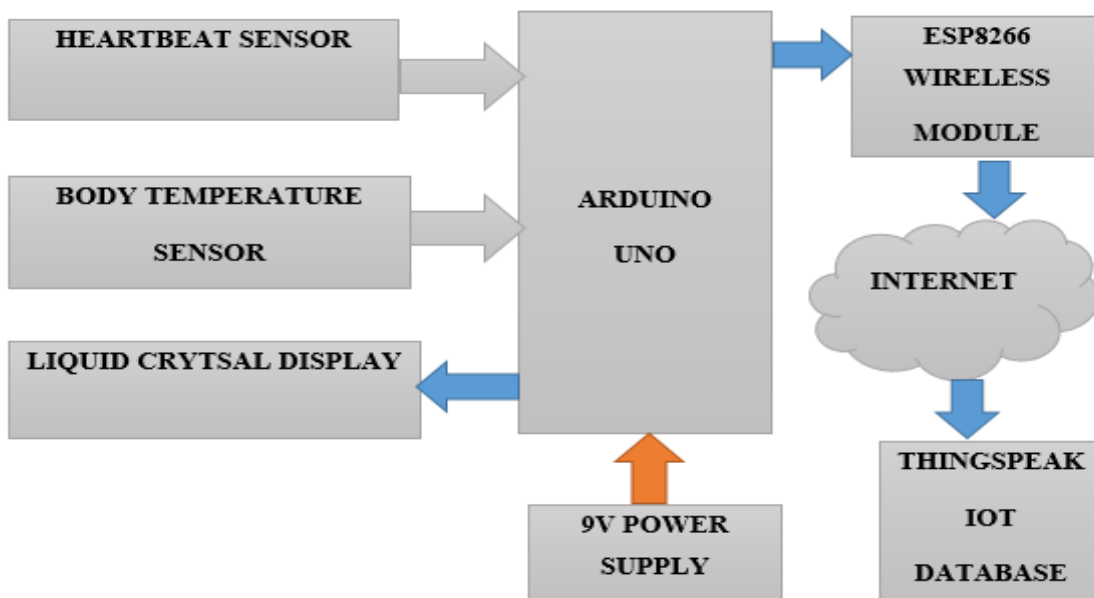


Figure 2: Block Diagram of the Developed System

### 3.4 Hardware Requirements

The hardware devices used for the project are summarized in Table 1.

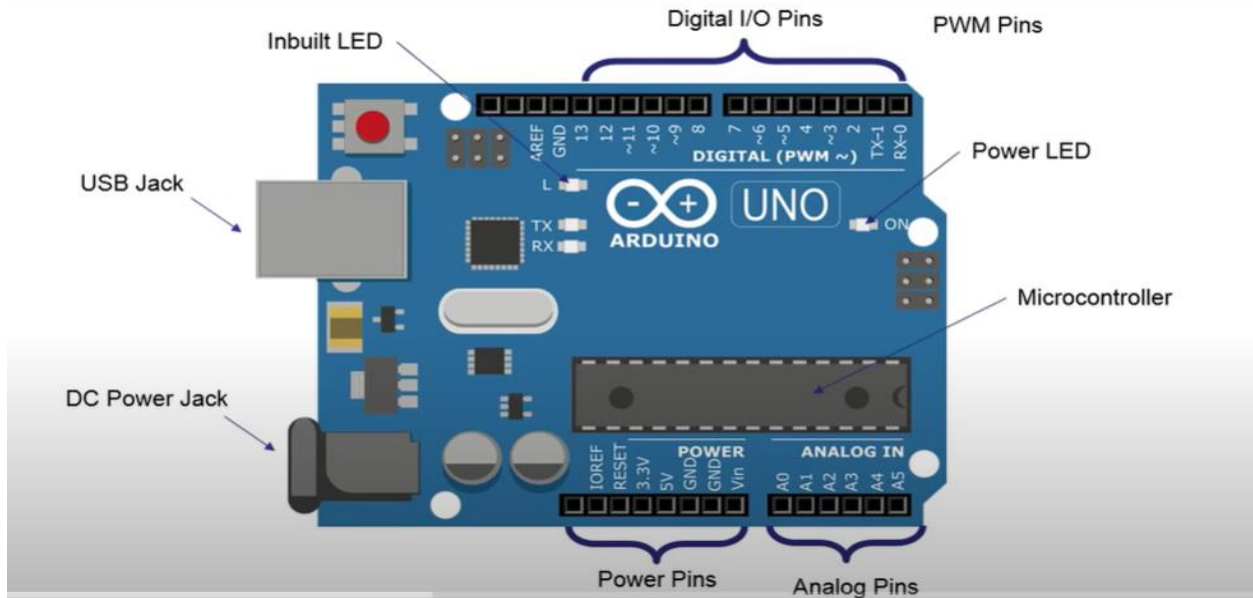
**Table 1: Project Requirements**

S/N	Component Required	Quantity
1	Arduino Uno	1
2	Heartbeat Sensor	1
3	MLX90614 Sensor	1
4	ESP8266 module	1
5	Breadboard	2
6	Battery	2
7	Jumper wires	1 packet
8	Liquid Crystal Display LCD	1
9	Potentiometer	1

#### 3.4.1 Arduino UNO

Arduino Uno is an embedded development board having different pins for analog, pulse width modulation (PWM) and digital signal interfacing. Arduino include an integrated development environment for programing. The Arduino development board is used to interface sensors which is use to collect data from the environment.

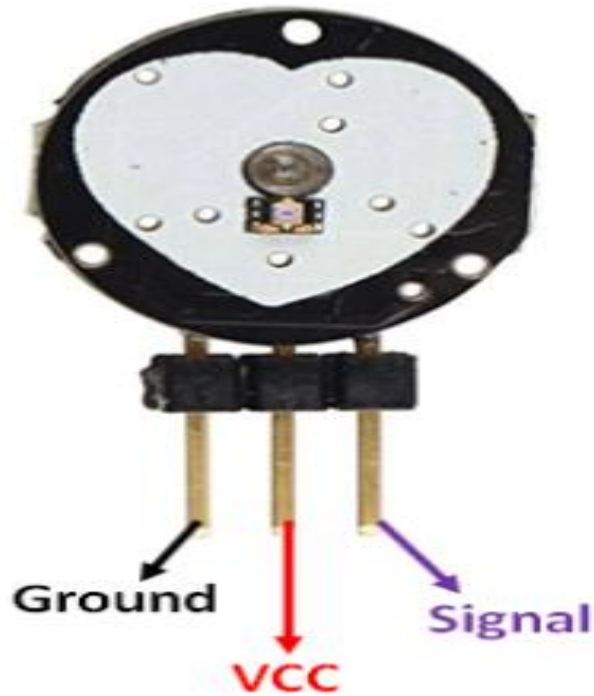
The Arduino board contains a microprocessor ATMEGA32 which was programmed to sense body temperature and heartbeat. The Arduino hardware comes in many flavors which include UNO, Nano, Mini, Mega, Leonardo, Esplora, Due and Lilypad. In this project Arduino UNO shown in Fig. 3 below was used because of its cost, availability of libraries and simplicity.



**Figure 3: Arduino Hardware**

### 3.4.2 Heartbeat Sensor

Pulse Sensor shown in Fig. 4 is a heartbeat sensor designed for Arduino. It can be used to incorporate heartbeat monitoring projects for real time pulse. The sensor side with the heart logo is usually placed onto a fingertip or earlobe to take measurements of the heartbeat. The sensor has three jumper cables which are plugged into Arduino pins. The sensor side with a heart logo contains the LED indicator and an ambient light sensor. The light from the LED strikes the fingertip, earlobe or other body part and reflected light is then used by the sensor in order to determine the heartbeat rate (Maxim Integrated, 2014). In this project the sensor signal cable was connected to pin A0, the ground pin to GND pin of Arduino and VCC pin was connected to 3.3V pin of Arduino.



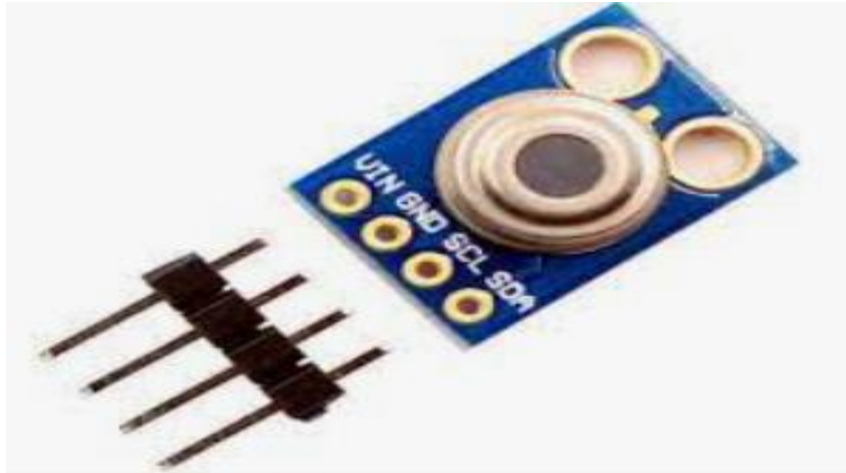
**Figure 4: Heartbeat Sensor**

### **3.4.3 MLX90614 Contactless Temperature Sensor**

The MLX90614 contactless temperature sensor measures both ambient and body temperatures. However, for this project the element of ambient temperature was ignored as the aim of the system was focused on body temperature. The sensor utilizes infrared (IR) to be able to detect the ambient and target temperature without coming into physical contact. It utilizes the inter-integrated circuit (I2C) serial communication protocol when communicating with microcontroller or other devices. It consists of four pins: SDA, VIN, GND, and SCL. The SDA pin is used for data transfer while SCL pin is used for clock transfer during I2C serial communication and VIN and GND is for power supply respectively. This sensor can be used in a number of commercial, health care and household applications like room temperature and body temperature. This sensor measure temperature of target without making physical contact due to the principle of *Stefan-Boltzmann Law*. All human beings emit IR energy and the MLX90614 sensor can calculate the temperature of a target from the emitted IR energy since temperature is directly proportional to it.

For this project SDA pin was connected to the SDA pin of Arduino, SCL was connected to the SCL of the Arduino, while VIN pin was connected to 5V, and the GND to the GND of Arduino.

The contactless temperature sensor shown in Fig. 5 was used for this project because of its fast response and exposure times and its long lasting.



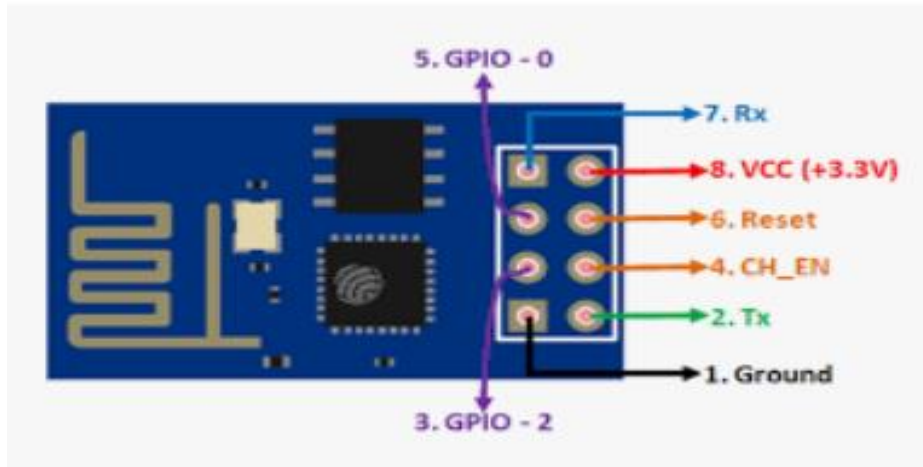
**Figure 5: MLX90614 Contactless Temperature Sensor**

### **3.4.4 ESP8266 Wireless Module**

The ESP8266 module provides a complete wireless fidelity networking solution; it can be used as standalone host receiving internet connection from a router or as a master providing internet connection to other devices.

When the ESP8266 module is used to host application, it is booted directly from an external flash. It has on-chip memory to enhance the capacity of the developed applications. This module has an antenna, radio frequency (RF) antenna, filters, power and low noise amplifiers as well as other power management mechanisms within a small board. The ESP8266 module also integrates a 32-bit processor, on-chip static random access memory (SRAM) with the ability to communicate with external devices and sensors using the GPIO pins.

For this project the ESP8266 wireless module shown in Fig. 6 was used and the pins were connected as follows: Tx pin to pin 2 of Arduino, Rx to pin 3 of Arduino, pins VCC and CH\_EN connected to 3.3V and Reset and ground pins to GND of Arduino.



**Figure 6: ESP8266 Wireless Module**

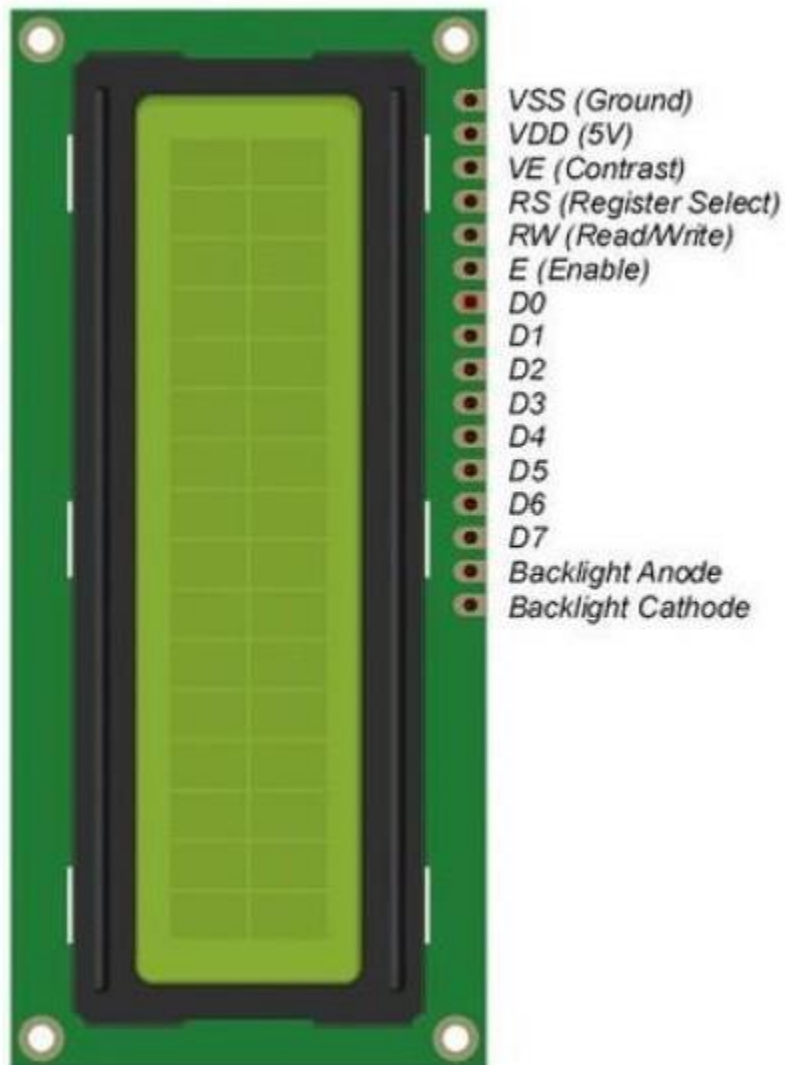
### 3.4.5 Liquid Crystal Display

A Liquid crystal display (LCD) shown in Fig. 7 was used for this project, this is a 16 by 2 LCD which displays only 32 characters. This was used to optimize cost and was also able to meet the project demands. This LCD is a 16 pin device which can display values when programmed with the help of Liquid Crystal library. The 16 pins include: VCC pin which is the power supply for the LCD and was connected to the Arduino's 5V while GND pin goes to Arduino's ground pin (0V). The V0 pin controls the contrast of the LCD and is connected to 5V for maximum brightness or to output pin of the potentiometer for brightness adjustments. The register selects (RS) pin is used to select between control command signals for LCD and data. RS pin is connected to ground (LOW) to send command signals to the LCD and to 5V (HIGH) to send data. Read/Write (R/W) pin is used select read or write mode, connecting the pin to HIGH reads data from LCD while setting it to LOW sends data to the LCD. Enable (EN) pin is used to enable or disable LCD using HIGH and LOW signals respectively. Anode (A) and cathode (K) pins are used to power LCD backlight by connecting to VCC and GND pins of Arduino respectively. The data buses (D0-D7) pins are used to carry data and commands between LCD and Arduino.

There are two modes used to send data, namely 8-bit and the 4-bit modes. For 8-bit mode, a byte is sent at once in pins D0 to D7 whereas in a slower 4-bit mode, four bits are sent in pins D4 to D7 twice.



In this project a 4-bit mode connection was used in order to reduce the number of cables used. Pin 1 was connected to ground, VCC to 5V, V0 to output pin of the potentiometer, R/W to the ground, EN to pin 11, RS to pin 12, D7, D6, D5, D4 to Arduino's pins 4, 5, 6, 7 respectively, Anode to 5V and cathode to ground.



**Figure 7: Liquid Crystal Display**

### **3.4.6 Potentiometer**

The potentiometer is a variable resistor with usually 3 pins; GND, VCC and output pins. In this project the brightness of the LCD was controlled by a 10K potentiometer shown in Fig. 8. The

potentiometer ground pin was connected to Arduino's GND pin and VCC to 5V of Arduino while the output pin was connected to the  $V_o$  of the LCD.



**Figure 8: Potentiometer**

### **3.5 Integrated Development Environment for Arduino**

The Arduino Integrated development environment (IDE) is a software which includes code editor, compiler and uploader to upload programs to a board. The text editor used for coding and the codes are uploaded to the Arduino hardware via a serial communication.

### **3.6 ThingSpeak IOT Cloud Database**

ThingSpeak is a web service that allows the collected sensor data to be stored in the cloud and aids the development of Internet of Things (IoT) applications (Pasha, 2020). It works with different development boards like Arduino, Raspberry Pi and LPC1768 microcontroller. It uses REST API and HTTP that allows use with various programming languages. The sensor data from the Arduino are transferred to the cloud database for storage, processing and visualization. ThingSpeak service also allows performing online analysis on the data. For this project an account was created in ThingSpeak and one channel called “contactless sensor” was set up having three fields. The first field is for the Ambient Temperature, second field for Body Temperature and the third field for Heartbeat values. Each channel has a unique channel identifier (ID) and application programmable interface (API) write and read keys and must be included in the coding. The write API key allows data to be sent to a channel while the read API allows data from a personal channel to be viewed

by others. For this project the write API “*Y2HQ4ZOYATCB8EE4*” was used to allow sensor data get sent to the ThingSpeak database.

## CHAPTER FOUR

### RESULTS AND DISCUSSION

#### 4.1 Introduction

This chapter looks at the results and makes discussions of the developed monitoring system for body temperature and heartbeat for chronic patients.

The project developed a system prototype that monitors body temperature and heartbeat rate for chronic patients. The prototype revealed that the patient's body temperature and heartbeat rate were processed and transferred to the ThingSpeak database for virtualization and analysis. Telemedicine doctors were able to access the stored data in the cloud for quick analysis. This helps the doctors to track the patient's data in real time. The developed system aids in creating awareness in the areas of telemedicine and improving chronic patient's management. The developed system in Fig. 11 is a combination of hardware and software, and the program code were written in Arduino IDE using the embedded C language as shown in Appendix 1.

#### 4.2 Results on Liquid Crystal Display

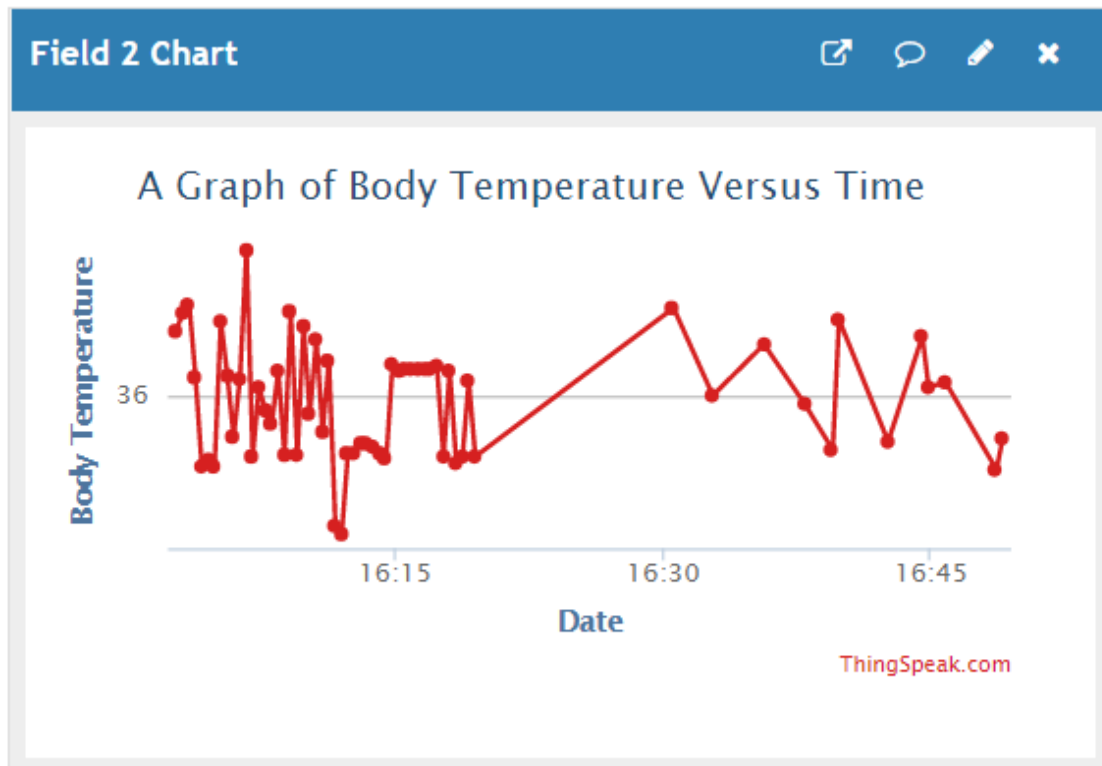
A 16 by 2 LCD was used to display the patient's body temperature and heartbeat readings. The patients can see their body temperature and heartbeat readings on LCD while at the same time the readings are sent to the cloud database for the doctors to track a patient's records. The body temperature and heartbeat readings that were taken by the developed system and displayed on the LCD are in Appendix 5 and Appendix 6 respectively.

#### 4.3 ThingSpeak Online Cloud Service

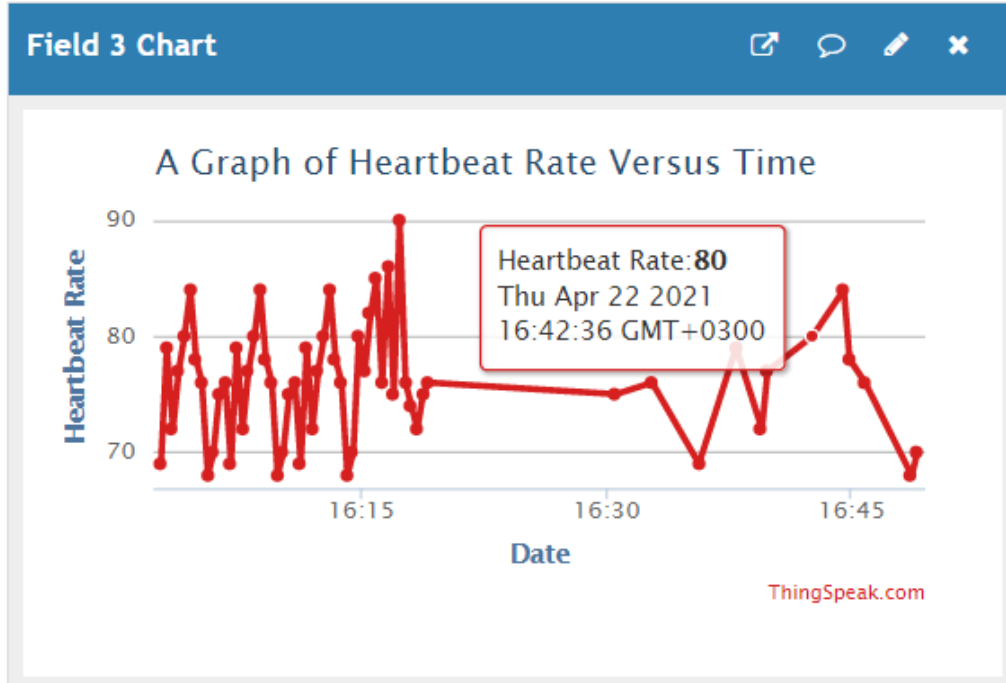
The body temperature and heartbeat rate readings collected by the sensors were processed by the Atmega32 microprocessor inside the Arduino board and was transferred to ThingSpeak using ESP8266 module. The ThingSpeak cloud service was utilized to store and analyze the patient's data. The data was analyzed and virtualized online using MATLAB provided as part of the cloud services. ThingSpeak was configured in order to receive body temperature and heartbeat readings from different distributed sensors. The readings are virtualized and organized in a graphical form in terms of line graphs in different fields. The fields receive real time data from the sensor nodes

corresponding to sensor body readings. The Fig. 9 and Fig. 10 show the body temperature and heartbeat readings taken by the system. These readings were sent, stored and visualized on Thingspeak IOT cloud database. The aggregated data can also be extracted in excel format for offline, allowing doctors to analyze patient's data on a local storage.

Seventy people were examined by the system and their body temperature and heartbeat readings were displayed on the LCD and at the same time sent to the cloud database. The normal body temperature is  $37^{\circ}\text{C}$  and a person is said to have fever when the temperature is greater than  $38.0^{\circ}\text{C}$  (Sund-Levander & Grodzinsky, 2012) while body temperature between  $35.5^{\circ}\text{C}$  to  $37^{\circ}\text{C}$  is usually regarded as fine when accessing a patient's condition depending on the time of the day. Therefore, the temperatures taken by the developed system as shown in Fig. 9 below mostly falls within the normal body temperature category.

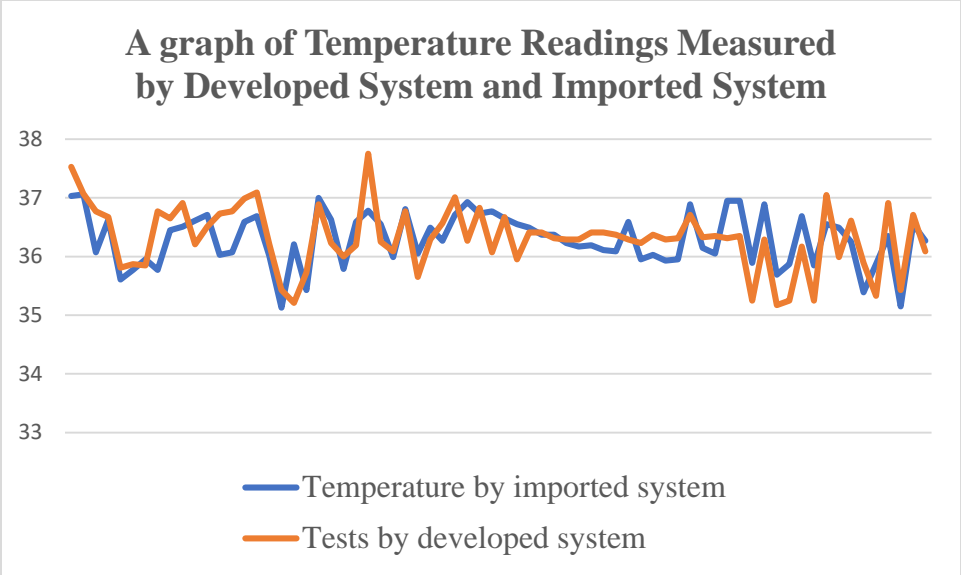


**Figure 9: ThingSpeak Capture of Body Temperature Readings**

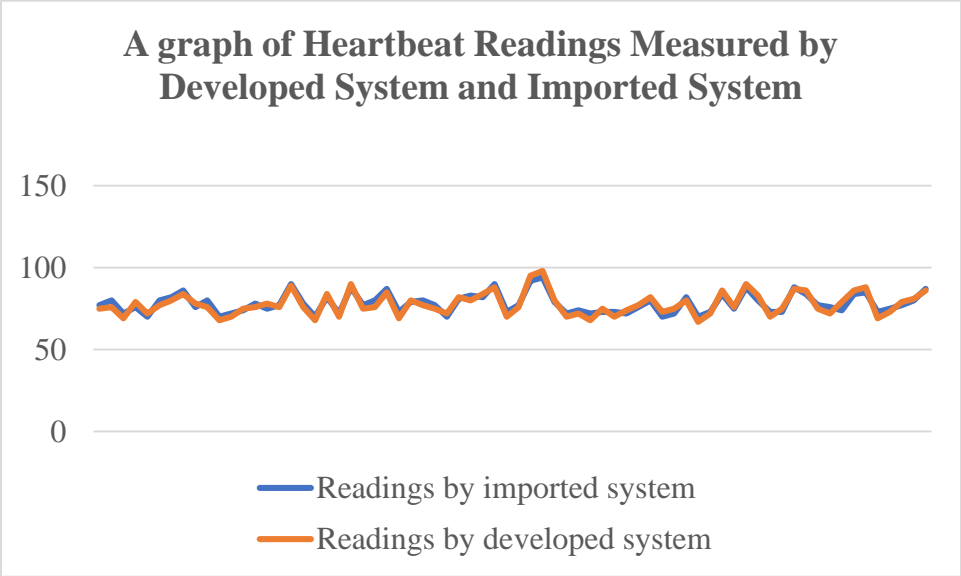


**Figure 10: ThingSpeak Capture of Heartbeat Readings**

Whenever the heart pumps blood, there is an increase in oxygenated blood whereas a decrease in oxygenated blood occurs when the heart relaxes. The heartbeat rate measured in beats per minute (BPM) is basically determined by the amount of time between the increase and decrease in the oxygenated blood. The normal BPM for adults is about 72, for children it is about 90 and for babies about 120 (Mallick & Patro, 2016). The BPM values shown in Fig. 10 were taken from adults and children only as it was difficult to find babies at the time of testing. The body temperature and heartbeat readings of seventy participants were done using the developed system and the imported devices at TMCG and the comparison are summarized in Appendix 7 and Appendix 8 respectively. The readings were virtualized for easy analysis as shown in Fig. 11 and Fig. 12. From Appendix 7 the efficiency of the temperature measurement of the developed system is 98.2%. The efficiency was calculated by multiplying the difference between the averages of the readings by 100%. From Appendix 8 the efficiency is about 90% for the heartbeat readings.



**Figure 11: Comparison of Temperature Readings**



**Figure 12: Comparison of Heartbeat Readings**

**4.4 Validation**

Validation is the procedure of checking key indicators aimed at verifying whether the specifications for the system satisfy the intended purpose. It is meant to check whether the user specifications and requirements are realized. Validation is therefore a means to check that specifications was well stated and proof that the required system specifications have been realized (Kamalrudin & Sidek, 2015).

For this developed system, different approaches were used for validation, including; unit test, integration test and system test. The summary of the testing is shown in Table 2.

**Table 2: System Testing Results**

<b>Requirement</b>	<b>Description</b>	<b>Test Score</b>
<b>Power up LED indicator</b>	When the different devices were connected to the power supply and the power indicator LEDs observed.	Pass
<b>Interfacing sensors with Arduino board</b>	After programming the output of the sensor, measurements was checked on Arduino serial monitor.	Pass
<b>LCD was added to the setup</b>	The measured readings from the sensors were programmed to be shown on the LCD and this was observed.	Pass
<b>Visualization of data</b>	A hardware setup was interfaced with the IOT cloud database. The sensor data were visualized in graphical form.	Pass
<b>Excel Report</b>	After visualization, the sensor data was extracted in an Excel format for further analysis on the local machine.	Pass
<b>Validation of the accuracy of the readings</b>	The system readings were compared to the readings from other devices at the TMCG clinic.	Pass

#### 4.4.1 Unit Test

Unit testing is a technique used to verify functional correctness of the each module of the system (Dybå & Dingsøy, 2008). For this developed system, the following modules were tested: ESP8266 module, heartbeat sensor, contactless temperature sensor, LCD and potentiometer. Each was tested for proper powering and the interfacing with Arduino was checked for proper functionality.



#### **4.4.2 Integration Test**

This is a testing technique that is used to verify whether the modules tested in the unit testing stage can be integrated to work smoothly and properly without any problems (Nidhra, 2012). Different functional modules were integrated and tested to confirm whether they were able to work together properly. For instance, the two sensors were all connected in addition to ESP8266, potentiometer and LCD in a bottom up approach and tested for any possible errors. The integration test was done by combining modules bit by bit to make sure they were working properly.

#### **4.4.3 System Test**

System testing is a technique of putting the system as whole and carrying out tests to proof whether it is working as planned and that it meets the intended end user's requirements. The combined outcome of all the modules put together was successfully tested during this system testing stage. System testing does not look at the structural dimension of program codes but rather the visible functional correctness of the end product.

The hardware was interfaced with ThingSpeak cloud database for data storage and virtualization. After the interfacing, the system was tested as a whole and was found to perform according to plan.

## CHAPTER FIVE

### CONCLUSION AND RECOMMENDATIONS

#### 5.1 Conclusion

Fewer health facilities in rural areas especially in Africa, is a serious hindrance to healthcare access. This poses serious risks and is even more paramount in chronic patients. The advancement of wireless sensor networks and cloud computing technology has created an opportunity for adopting telemedicine. In this project, a system capable of monitoring body temperature and heartbeat rate of chronic patients has been developed. This system is capable of sending real time patient's data to a cloud database. This system will bridge the gap in healthcare access caused by the insufficient healthcare facilities in rural areas and will further improve the way of managing chronic patients as well as dealing with any sudden changes in the patient's health condition. The developed system consists of a heart pulse sensor, a MLX90614 contactless temperature sensor, an ESP8266 wireless module, LCD, an Arduino board and cloud database. The cloud database virtualizes the received data in a graphical and spreadsheet formats for easy analysis. The system has the potential of adding more health indicators for monitoring as may be required by doctors. The doctor logs into the ThingSpeak account to check the patient's data and can also retrieve the data by extracting an excel document from the ThingSpeak database. The system when integrated with TMCG electronic medical record (EMR) system will make readings outside normal ranges to pop up on the EMR dashboard in order to alert the doctors.

Some of the challenges encountered in the project included the difficulties in finding the required devices, health monitoring sensors such as MAX30100, MAX30205 in the local markets. This increases the period of doing the project due to the waiting time for the devices to be imported. To mitigate this, an alternative MLX90614 was used for the project since it was readily available.

#### 5.2 Recommendations

The policy makers, government, and different stakeholders like the ISPs should increase the internet coverage to enable such systems to be used in rural areas where health facilities are usually distant. Various stakeholders in the health sector should be able to sensitize the citizens on the use

of telemedicine as an alternative to physical visits to health facilities. This will greatly save time and enable quality services to reach even rural areas from any location.

In future, more research can be done in areas of adopting sensors to improve remote patient monitoring in order to improve telemedicine and general health care systems. This project can be further improved by incorporating a dashboard pop up mechanism for immediate alerts.

## REFERENCES

- Alison, G., Onkokame, M., Ali, N., & Tusu, T. (2019). *The State of ICT in Uganda*. [https://researchtafrica.net/2019\\_after-access-the-state-of-ict-in-uganda/May](https://researchtafrica.net/2019_after-access-the-state-of-ict-in-uganda/May)
- Beran, D. (2012). Health systems and the management of chronic diseases: Lessons from Type 1 diabetes. *Diabetes Management*, 2(4), 323-335.
- Blind, U., & Peri, K. (2006). Uganda Vision 2040. *In annual meeting of the Midwest Political Science*, 12(3), 1-7. [http://web.stanford.edu/class/e297a/Neo-Colonialism in Africa.pdf](http://web.stanford.edu/class/e297a/Neo-Colonialism%20in%20Africa.pdf)  
[https://eeas.europa.eu/sites/eeas/files/uganda-fr-forprint-14-04\\_2016\\_en\\_0.pdf](https://eeas.europa.eu/sites/eeas/files/uganda-fr-forprint-14-04_2016_en_0.pdf)  
[https://reliefweb.int/sites/reliefweb.int/files/resources/85C0E269BAF5E780C12577B300447BADFull\\_Report.pdf](https://reliefweb.int/sites/reliefweb.int/files/resources/85C0E269BAF5E780C12577B300447BADFull_Report.pdf)
- Dybå, T., & Dingsøy, T. (2008). Empirical studies of agile software development: A systematic review. *Information and Software Technology*, 50(10), 833–859. <https://doi.org/10.1016/j.infsof.2008.01.006>
- Institute for Health Metrics and Evaluation. (2017). *Findings from the Global Burden of Disease Study*.
- Jadhav, V., & Tadwalkar, M. B. (2015). Wireless Data Acquisition System Using ARM Cortex M-3. *Journal of Electronics and Communication Engineering*, 10(1), 32–35. <https://doi.org/10.9790/2834-10113235>
- Kamalrudin, M., & Sidek, S. (2015). A review on software requirements validation and consistency management. *International Journal of Software Engineering and Applications*, 9(10), 39–58. <https://doi.org/10.14257/ijseia.2015.9.10.05>
- Madhu, N. R. J. (2017). *IoT based Remote Patient Health Monitoring System*. <https://core.ac.uk/download/pdf/132492107.pdf>

- Mallick, B., & Patro, A. K. (2016). Heart Rate Monitoring System using Finger Tip Through Arduino. *International Journal of Science, Engineering and Technology Research*, 5(1), 84–89.
- Maxim Integrated. (2014). MAX30100 Pulse Oximeter and Heart-Rate Sensor IC for Wearable Health. *Lecture Notes in Energy*, 38, 11–37. [www.maximintegrated.com](http://www.maximintegrated.com)
- National Center for Chronic Disease Prevention and Health Promotion. (2019). *Chronic Disease in America*. 1–3. [www.cdc.gov/chronicdisease](http://www.cdc.gov/chronicdisease)
- Nidhra, S. (2012). Black Box and White Box Testing Techniques: A Literature Review. *International Journal of Embedded Systems and Applications*, 2(2), 29–50. <https://doi.org/10.5121/ijesa.2012.2204>
- Nugent, R., David, B., Stéphane, V., Ryan, H., & Prabhat, J. (2012). Chronic Disease. *Chronic Disease Prevention and Control*, 3, 3-8.
- Parihar, V. R., Tonge, A. Y., & Ganorkar, P. D. (2017). Heartbeat and Temperature Monitoring System for Remote Patients using Arduino. *International Journal of Advanced Engineering Research and Science*, 6495(5), 55–58.
- Pasha, S. (2020). Thingspeak Based Sensing and Monitoring System for IoT with Matlab Analysis. *International Journal of New Technology and Research*, 6, 19–23.
- Prabha, M. G. M. (2018). Health monitoring system using Raspberry PI. *International Journal of Pure and Applied Mathematics*, 118(8), 613–619. <https://doi.org/10.1109/BID.2017.833658>
- Priyanka, K., Tripathi, N. K., & Peerapong, K. (2015). A real-time health monitoring system for remote cardiac patients using smartphone and wearable sensors. *International Journal of Telemedicine and Applications*, 2015, 373-379. <https://doi.org/10.1155/2015/373474>
- Salman, M., Muhammad, D., Ali, S., & Abdul, Q. A. (2018). Design of Android-Based Remote Patient Monitoring System. *International Journal of Advanced Computer Science and Applications*, 9(6), 189–192.

- Sensors, H., & Forever, D. A. (2020). *Real-time and Remote Patient Monitoring Trends*.  
[https://www.te.com/content/dam/te-com/documents/sensors/global/real-time\\_and\\_remote\\_patient\\_monitoring\\_trends.pdf](https://www.te.com/content/dam/te-com/documents/sensors/global/real-time_and_remote_patient_monitoring_trends.pdf)
- Sherin, S., Neethu, R.J., Yedu, M., Anand, V. R., & Jayashree, M. J. (2012). Remote Patient Monitoring System. *International Journal of Distributed and Parallel Systems*, 3(5), 99–110.
- Srinivasan, P. A., Ayub, K. T., Prabu, M., Manoj, M., & Ranjan, K. K. (2020). Heart Beat Sensor using Fingertip through Arduino. *Journal of Critical Reviews*, 7(7), 1058–1060.
- Sund-Levander, M., & Grodzinsky, E. (2012). Accuracy when assessing and evaluating body temperature in clinical practice: Time for a change? *Thermology International*, 22(3), 25–32.
- The Uganda Non-Communicable Diseases Alliance Strategic Plan. (2016). *Technical Report*.  
<https://ncdalliance.org/sites/default/files/Sample%20UNCDA%20Draft%20Strategic%20plan%202016%20-%202019.pdf>
- Yassin, F. M., Sani, N. A., & Chin, S. N. (2019). Analysis of Heart Rate and Body Temperature from the Wireless Monitoring System Using Arduino Analysis of Heart Rate and Body Temperature from the Wireless Monitoring System Using Arduino. *Journal of Physics: Conference Series*, 1358, 98. <https://doi.org/10.1088/1742-6596/1358/1/012041>

## APPENDICES

### Appendix 1: Codes for Heartbeat Sensor Interfacing with Arduino Nodes

```
#define USE_ARDUINO_INTERRUPTS true //set up low level interrupts for most accurate BPM
math
#include <PulseSensorPlayground.h >
#include <Wire.h>
#include <Adafruit_MLX90614.h>
#include <LiquidCrystal.h>
const int rs = 12, en = 11, d4 = 5, d5 = 4, d6 = 3, d7 = 2;
LiquidCrystal lcd (rs, en, d4, d5, d6, d7);
Adafruit_MLX90614 mlx = Adafruit_MLX90614();
const int PulseWire =0;
const int LED_3 = 13;
int Threshold = 550;
PulseSensorPlayground pulseSensor;
void setup () {
  Serial.begin (9600);
  mlx.begin ();
  lcd.begin(16, 2);
  lcd.clear();
  pulseSensor.analogInput(PulseWire);
  pulseSensor.blinkOnPulse (LED_3);
  pulseSensor.setThreshold(Threshold);
  if (pulseSensor.begin()) {
    lcd.clear();
    lcd.setCursor(0,0);
    lcd.print ("Health System");
    lcd.setCursor(0,1);
    lcd.print ("Touch on Sensor ");
  }
}
```

```
}  
void loop () {  
  lcd.setCursor(0, 1);  
  int myBPM = pulseSensor.getBeatsPerMinute ();  
  if (pulseSensor.sawStartOfBeat ())  
  {  
    lcd.print ("A HeartBeat Happened!");  
    Serial.println (" A HeartBeat Happened! ");  
    Serial.print ("BPM: "); //print phrase "BPM: "  
    Serial.println (myBPM);  
    lcd.clear();  
    lcd.setCursor(0,0);  
    lcd.print ("Health System");  
    lcd.setCursor(0,1);  
    lcd.print ("BPM ");  
    lcd.print(myBPM);  
  }  
  delay (100);  
}
```



## Appendix 2: Codes for Temperature Sensor Interfacing with Arduino Nodes

```
#include <Adafruit_MLX90614.h>
#include <OneWire.h>
#include <Adafruit_ESP8266.h>
#include <AltSoftSerial.h>
#define MLX 2
Adafruit_MLX90614 mlx = Adafruit_MLX90614();
String apiKey = "Y2HQ4ZOYATCB8EE4"; // Write API key from ThingSpeak
const char* ssid = "Obira"; // WiFi SSID
const char* pass = "59405041"; // WiFi Network's Password
const char* server = "api.thingspeak.com";
float temp;
OneWire ourWire(MLX90614);
MLX90614 sensor(&ourWire);
WiFiClient client;
void setup ()
{
  Serial.begin(115200);
  delay (1000);
  sensor.begin();
  Serial.print("Connecting to: ");
  Serial.println(ssid);
  WiFi.begin(ssid, pass);
  while (WiFi.status() != WL_CONNECTED)
  {
    delay (100);
    Serial.print("*");
  }
  Serial.println("");
  Serial.println("***WiFi connected***");
}
```

```

void loop ()
{
  sensor.requestTemperatures();
  temp = sensor.getTempCByIndex(0);
  if (client.connect(server,80) // "184.106.153.149" or api.thingspeak.com
  {
    String sendData = apiKey+"&field1="+String(temp)+"\r\n\r\n";
    //Serial.println(sendData);
    client.print ("POST /update HTTP/1.1\n");
    client.print ("Host: api.thingspeak.com\n");
    client.print ("Connection: close\n");
    client.print ("X-THINGSPEAKAPIKEY: "+apiKey+"\n");
    client.print ("Content-Type: application/x-www-form-urlencoded\n");
    client.print ("Content-Length: ");
    client.print (sendData.length());
    client.print("\n\n");
    client.print(sendData);
    Serial.print("Temperature: ");
    Serial.print(temp);
    Serial.println("deg C. Connecting to Thingspeak...");
  }
  client.stop();
  Serial.println("Sending...");
  delay (10000);
}

```

### Appendix 3: Codes for the Complete Developed System

```
#include <SoftwareSerial.h>
#include <Wire.h>

#include <Adafruit_MLX90614.h>

#include <PulseSensorPlayground.h >

#define USE_ARDUINO_INTERRUPTS true

String apiKey = "Y2HQ4ZOYATCB8EE4";

SoftwareSerial ser (2, 3); // RX, TX

Adafruit_MLX90614 mlx = Adafruit_MLX90614();

const int PulseWire = 0;

const int LED_3 = 13;

int Threshold = 550;

PulseSensorPlayground pulseSensor;

int randomNo;

void setup () {

pulseSensor.analogInput(PulseWire);

pulseSensor.blinkOnPulse (LED_3);

pulseSensor.setThreshold(Threshold);

pulseSensor.begin();

ser.begin(115200);

Serial.begin(9600);

mlx.begin ();

unsigned char check_connection=0;
```

```

unsigned char times_check=0;

Serial.println("Connecting to Wifi");

while(check_connection==0)

{

Serial.print("..");

ser.print("AT+CWJAP=\"Obira\", \"59405041\"\\r\\n");

ser.setTimeout(5000);

if (ser.find("WIFI CONNECTED\\r\\n")==1 )

{

Serial.println("WIFI CONNECTED");

break;

}

times_check++;

if(times_check>3)

{

times_check=0;

Serial.println("Trying to Reconnect...");

}

}

delay (5000);

}

void loop ()

{

```

```

int myBPM = pulseSensor.getBeatsPerMinute();

if (pulseSensor.sawStartOfBeat()) { //if test is true, then the following conditions will be executed

Serial.println (" A HeartBeat Happened! "); //print a message A heartbeat happened

Serial.print ("BPM: "); //print phrase "BPM: "

Serial.println (myBPM);

String cmd = "AT+CIPSTART=\\"TCP\\,\\"";

cmd += "184.106.153.149"; // api.thingspeak.com

cmd += "\",80";

ser.println(cmd);

if(ser.find("Error")){

Serial.println("AT+CIPSTART error");

return;

}

String getStr = "GET /update?api_key=";

getStr += apiKey;

getStr += "&field1=";

getStr += String(mlx.readAmbientTempC());

getStr += "&field2=";

getStr += String(mlx.readObjectTempC());

getStr += "&field3=";

getStr += String (pulseSensor.getBeatsPerMinute());

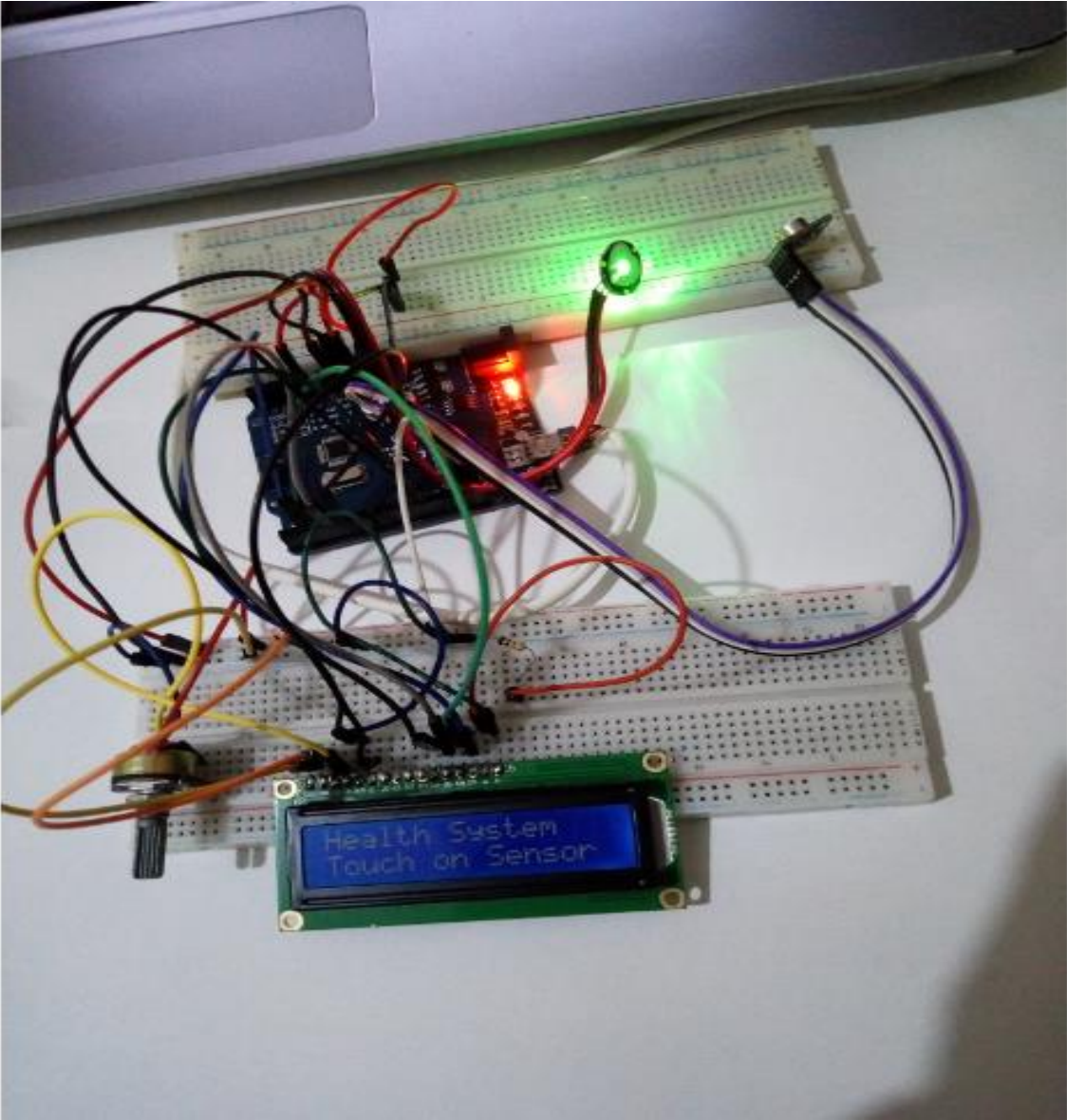
getStr += "\r\n\r\n";

cmd = "AT+CIPSEND=";

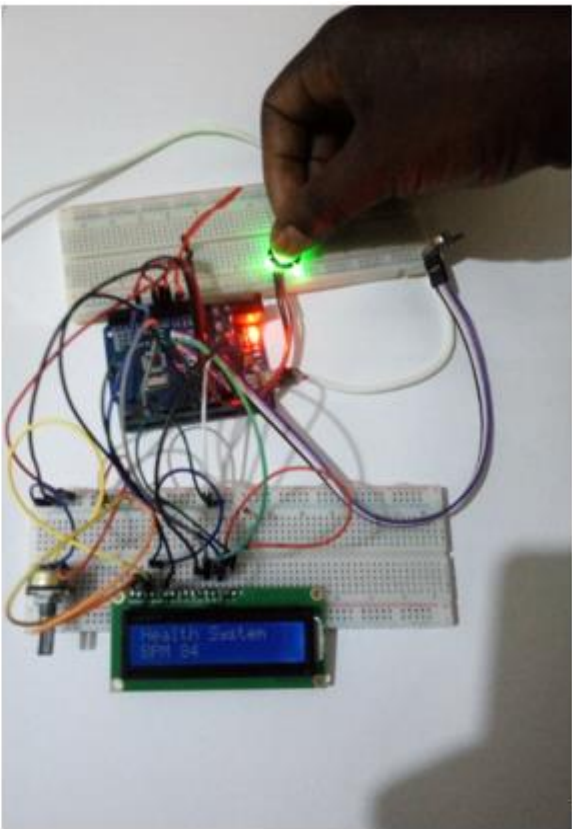
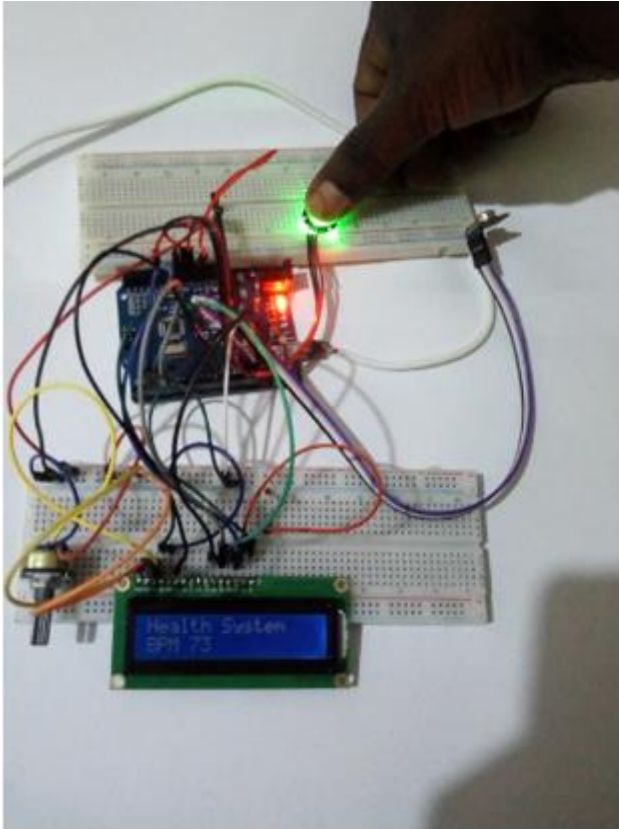
```

```
cmd += String (getStr.length());  
ser.println(cmd);  
if(ser.find(">")){  
ser.print(getStr);  
Serial.println(getStr);  
}  
else {  
ser.println("AT+CIPCLOSE");  
Serial.println("CIPCLOSE");  
}  
delay (16000);  
}  
}
```

**Appendix 4: Snapshot of the Developed System**

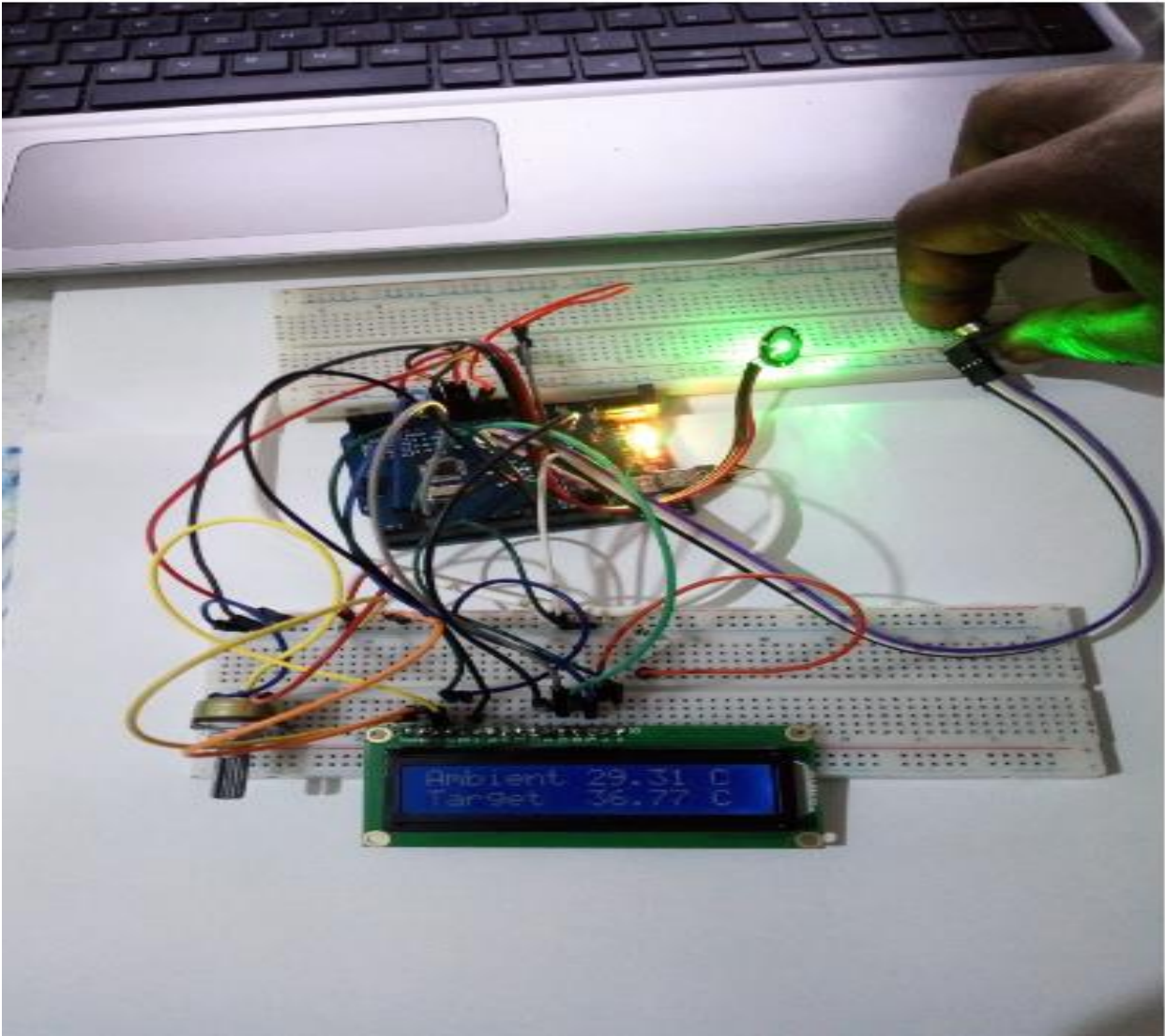


**Appendix 5: Snapshot of the Heartbeat Measurement**





**Appendix 6: Snapshot of the Body Temperature Measurement**



## Appendix 7: Temperature Readings Comparison

<b>Number of Tests Done</b>	<b>Readings by imported system</b>	<b>Readings by developed system</b>
1	37.03	37.53
2	37.06	37.07
3	36.07	36.77
4	36.63	36.67
5	35.61	35.81
6	35.77	35.87
7	35.95	35.85
8	35.77	36.77
9	36.45	36.65
10	36.51	36.91
11	36.61	36.21
12	36.71	36.51
13	36.03	36.73
14	36.07	36.77
15	36.59	36.99
16	36.69	37.09
17	36.01	36.21
18	35.13	35.43
19	36.21	35.21
20	35.43	35.73
21	37	36.89
22	36.63	36.23
23	35.79	36
24	36.59	36.19
25	36.78	37.75
26	36.55	36.25
27	35.99	36.09
28	36.81	36.77

29	36.05	35.65
30	36.49	36.29
31	36.27	36.57
32	36.71	37.01
33	36.93	36.27
34	36.73	36.83
35	36.77	36.07
36	36.65	36.67
37	36.55	35.95
38	36.49	36.41
39	36.37	36.41
40	36.37	36.31
41	36.23	36.29
42	36.17	36.29
43	36.19	36.41
44	36.11	36.41
45	36.09	36.37
46	36.59	36.29
47	35.95	36.23
48	36.03	36.37
49	35.93	36.29
50	35.95	36.31
51	36.89	36.71
52	36.15	36.33
53	36.05	36.35
54	36.95	36.31
55	36.95	36.35
56	35.89	35.25
57	36.89	36.29
58	35.69	35.17

59	35.87	35.25
60	36.69	36.17
61	35.85	35.25
62	36.55	37.05
63	36.49	35.99
64	36.25	36.61
65	35.39	35.89
66	35.87	35.33
67	36.35	36.91
68	35.15	35.43
69	36.55	36.71
70	36.27	36.09

## Appendix 8: Comparison of Heartbeat Readings

Number of Tests Done	Readings by imported system	Readings by developed system
1	77	75
2	80	76
3	72	69
4	76	79
5	70	72
6	80	77
7	82	80
8	86	84
9	76	78
10	80	76
11	70	68
12	72	70
13	74	75
14	78	76
15	75	78
16	77	76
17	90	89
18	78	76
19	70	68
20	82	84
21	72	70
22	88	90
23	77	75
24	80	76
25	87	85
26	73	69
27	79	80
28	80	77
29	77	75

30	70	72
31	81	82
32	83	80
33	82	84
34	90	88
35	73	70
36	77	76
37	92	95
38	94	98
39	79	80
40	72	70
41	74	72
42	72	68
43	73	75
44	73	70
45	72	74
46	76	77
47	80	82
48	70	73
49	72	75
50	82	80
51	70	67
52	73	72
53	84	86
54	75	76
55	88	90
56	80	83
57	73	70
58	73	75
59	88	87

60	84	86
61	77	75
62	76	72
63	74	79
64	84	86
65	85	88
66	73	69
67	75	73
68	77	79
69	80	81
70	87	86

## RESEARCH OUTPUTS

- i. **Output 1:** Okello, J. O., & Sinde, R. (2021). Development of a Sensor-Based Heartbeat and Body Temperature Monitoring System for Remote Chronic Patients, *Journal of Engineering, Technology and Applied Science Research*, 11(4), 7375-7380.
- ii. **Output 2:** Poster Presentation



## Output 2: Poster Presentation



### Development of a Sensor Based Heartbeat Rate and Body Temperature Monitoring System for Remote Chronic Patients

Jimmy Obira Okello, Dr. Ramadhani Sinde, Dr. Sam Anael

Nelson Mandela African Institution of Science and Technology, P. O. Box 447, Arusha, Tanzania.

E-mails: okelloj@nm-aist.ac.tz, ramadhani.sinde@nm-aist.ac.tz, anael.sam@nm-aist.ac.tz



#### INTRODUCTION/BACKGROUND

- ❑ A chronic disease is any health condition that persists for a year or more requiring continuous medical care.
- ❑ Globally, over 36 million deaths per year are attributed to chronic diseases.
- ❑ About 80% of the world's deaths from chronic diseases occur in low and middle-income countries.
- ❑ In sub-Saharan Africa, chronic disease account for 29.8% of all deaths

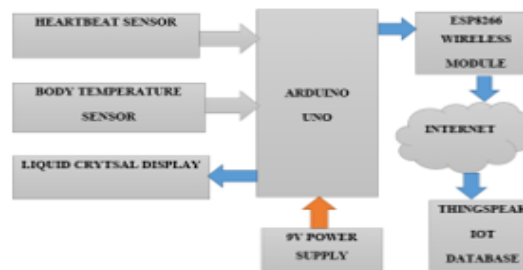
#### OBJECTIVES

**MAIN OBJECTIVE:** To develop a system that uses sensors to detect chronic patient's body temperature and heartbeat readings, relaying the readings to the cloud database in real time.

#### SPECIFIC OBJECTIVES

- ❑ To review existing systems used in chronic patient's management at the medical concierge group (TMCG) Uganda.
- ❑ To design a system that monitors patient's heartbeat rate and body temperature using sensors and sends the data to cloud database in real time.
- ❑ To develop and test the system with diabetic and hypertensive patients of TMCG to validate the usability and efficiency.

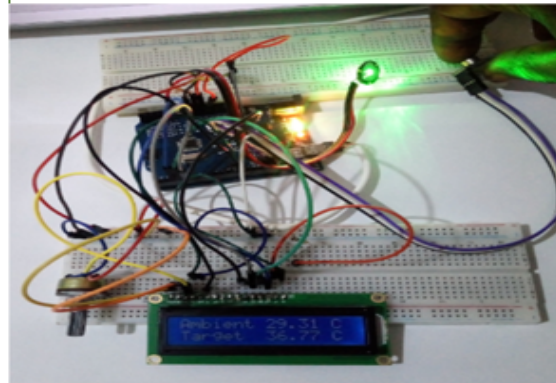
#### SYSTEM BLOCK DIAGRAM



#### PROBLEM STATEMENT

- ❑ There is an increasing burden of chronic disease management on the health sector world over.
- ❑ Monitoring the patient's body parameters, keeping their records and informing doctors in real time about any abnormality is still a challenge.
- ❑ The doctors also do not receive the patient's data in real time for immediate response in case of abnormality.

#### THE DEVELOPED SYSTEM PROTOTYPE



#### CONCLUSION

- ❑ The scarcity of health facilities in rural areas, especially in Africa, is a serious hindrance to healthcare access.
- ❑ A system capable of monitoring body temperature and heartbeat rate of chronic patients has been developed.
- ❑ This system is capable of sending patients' data to a cloud database in real time.
- ❑ This system will bridge the gap in healthcare access caused by the insufficient healthcare facilities.