

2022-01

# Development of swahili speaking body weight scale for visually impaired people in Tanzania

Nzasangamariya, Gloriose

NM-AIST

---

<https://doi.org/10.58694/20.500.12479/1589>

*Provided with love from The Nelson Mandela African Institution of Science and Technology*

**DEVELOPMENT OF SWAHILI SPEAKING BODY WEIGHT SCALE FOR  
VISUALLY IMPAIRED PEOPLE IN TANZANIA**

**Gloriose Nzasangamariya**

**A Project Submitted in Partial Fulfilment of the Requirements for the Degree of Masters  
of Science in Embedded and Mobile Systems of the Nelson Mandela African Institution of  
Science and Technology**

**Arusha, Tanzania**

**January, 2022**

## ABSTRACT

Speaking weight scale is an important low vision health aid which measures and announces out the measured weight. It is valuable in numerous applications such as Bathroom scale, Kitchen scale and more. Different talking scales have been developed for blind community. Many talking scales have language option for English, German, French or Spanish. However, only limited work exists for Swahili speaking visually impaired community in East African Community (EAC) given the fact that no talking scale can announce weight in Swahili, which is the common language in EAC. Therefore, this project aims to develop a Swahili speaking weighing machine to assist visually impaired people in Tanzania. The proposed speaking scale is divided into two major parts. On the front-end of the design, sensors are used to capture weight parameters. The captured values are mapped onto sequence of voice patterns. The back-end consists of transferring a sequence of voice patterns to a loudspeaker whereby the voice patterns are stored on an SD card. Finally, the developed device has been evaluated on several objects (certified scale calibration weights) with known weights. Each object was reweighed two times. Placed certified calibration weights on the scale and note the output. Took the measured object off the scale and let the scale return to zero. Placed the same object on the scale again. Noted the output again. The results then showed that the scale displayed the same weights on each object. The expected weight of given objects was then compared with the recorded ones to assess the performance of the scale. The results then showed that the scale is able to measure objects, displays digital output of measured weight and announce it in Swahili language within the accuracy of 1% error range of the actual weight. The proposed device has a great potential as a low vision health aid for Swahili speaking. The features of this device can be further improved to increase the autonomy of blind people to use the device and navigate to the device's location safely.

## DECLARATION

I, Gloriose Nzasangamariya do hereby declare to the Senate of the Nelson Mandela African Institution of Science and Technology that this dissertation is my own original work and that it has neither been submitted nor being concurrently submitted for degree award in any other institution.

Gloriose Nzasangamariya

---

Name and Signature of Candidate

Date

The above declaration is confirmed by:

Prof. Shubi F. Kaijage

---

Name and Signature of Supervisor 1

Date

Dr. Ramadhani S. Sinde

---

Name and Signature of Supervisor 2

Date

## **COPYRIGHT**

This dissertation is copyright material protected under the Berne Convention, the Copyright Act of 1999 and other international and national enactments, in that behalf, on intellectual property. It must not be reproduced by any means, in full or in part, except for short extracts in fair dealing; for researcher private study, critical scholarly review or discourse with an acknowledgement, without a written permission of the Deputy Vice Chancellor for Academic, Research and Innovation, on behalf of both the author and the Nelson Mandela African Institution of Science and Technology.

## CERTIFICATION

The undersigned certify that, they have read and hereby recommend for acceptance by the Senate of the Nelson Mandela African Institution of Science and Technology a project entitled “*Development of Swahili Speaking Body Weight Scale for Visually Impaired People in Tanzania*” in partial fulfilment of the requirement for the Degree of Masters of Science in Embedded and Mobile Systems of the Nelson Mandela African Institution of Science and Technology.

Prof. Shubi F. Kaijage

---

Name and Signature of Supervisor 1

Date

Dr. Ramadhani S. Sindi

---

Name and Signature of Supervisor 2

Date

## ACKNOWLEDGMENTS

Firstly, I would like to thank Almighty God for the gift of life and strength while pursuing my master's degree at the Nelson Mandela African Institution of Science and Technology. Secondly, I wish to prolong my genuine thanks to my supervisors Dr. Ramadhani S. Sinde and Prof. Shubi F. Kaijage, but also to Prof. Kabulepa D. Lukusa (Industry supervisor), for the earnest guide they gave me from the start of this project to its completion. I thank them very much. Dr. Ramadhani S. Sinde has walked with me to continually improve on the prototyping and I am grateful, without him I would not have made the good progress I have so far.

I would like to acknowledge the support of our sponsors CENIT@EA, the continued mentorship by lecturers from The Nelson Mandela African Institution of Science and Technology (NM-AIST). I further would like to acknowledge NM-AIST for the opportunity accorded me to conduct this project from the Embedded lab.

## TABLE OF CONTENTS

ABSTRACT.....	i
DECLARATION.....	ii
COPYRIGHT.....	iii
CERTIFICATION.....	iv
ACKNOWLEDGMENTS.....	v
TABLE OF CONTENTS.....	vi
LIST OF TABLES.....	x
LIST OF FIGURES.....	xi
LIST OF APPENDICES.....	xii
LIST OF ABBREVIATIONS AND SYMBOLS.....	xiii
CHAPTER ONE.....	1
INTRODUCTION.....	1
1.1 Background of the Study.....	1
1.2 Statement of the Problem.....	2
1.3 Rationale of the Study.....	3
1.4 Project Objectives.....	4
1.4.1 General Objective.....	4
1.4.2 Specific Objectives.....	4
1.5 Project Questions.....	4
1.6 Significance of the Study.....	4
1.7 Delineation of the Study.....	5
CHAPTER TWO.....	6
LITERATURE.....	6
2.1 An Overview of Bodyweight and Body Mass Index.....	6
2.2 Analog Scales.....	6
2.3 Digital Bathroom Scales.....	6



2.4	Talking Bathroom Scales.....	7
2.5	Swahili Speaking Body Weight Scale.....	7
2.6	Purpose and Motivation.....	8
CHAPTER THREE .....		10
MATERIALS AND METHODS .....		10
3.1	Overview .....	10
3.2	Materials .....	10
3.2.1	Load Cell.....	10
3.2.2	HX711 .....	11
3.2.3	Esp8266 NodeMCU.....	11
3.2.4	Max98357A Inter-Integrated Sound Audio Board.....	12
3.3	Software and Libraries .....	15
3.3.1	Arduino Integrated Development Environment .....	15
3.3.2	HX711 Library .....	15
3.3.3	EEPROM.....	15
3.3.4	ESP8260 Wi-Fi.....	15
3.3.5	WIFI User Datagram Protocol.....	15
3.3.6	Oled.....	15
3.3.7	FAT32 .....	15
3.3.8	Android Studio .....	16
3.3.9	WAVE Files .....	16
3.4	Methods .....	16
3.4.1	Study Area.....	16
3.4.2	Sample Size and Technique .....	16
3.4.3	Data Collection Methods.....	17
3.4.4	Data Analysis Method.....	17
3.4.5	Development method -Minimum Viable Product .....	18

3.4.6	System Design .....	18
3.4.7	Architectural Design .....	20
CHAPTER FOUR	.....	21
RESULTS AND DISCUSSION	.....	21
4.1	Overview .....	21
4.1.1	Existing Talking Bathroom Scales .....	21
4.1.2	Findings from Users in the Case study .....	21
4.2	Process of Implementation .....	25
4.2.1	Prototype - Design .....	25
4.2.2	The Connection between Load Cells and HX711 Module .....	26
4.2.3	Interfacing HX711 Module with Esp8266 NodeMCU over Serial Interface.....	27
4.2.4	Interfacing Secure Digital Card with Esp8266 NodeMCU over Serial Peripheral Interface.....	28
4.2.5	Interfacing Esp8266 NodeMCU with Max98357A Inter-Integrated Circuit Sound Audio Amplifier over Inter-Integrated Circuit Sound Interface.....	28
4.3	Results of the Device Design.....	30
4.4	Data Acquisition and Preparation .....	31
4.5	Device Operation .....	32
4.6	Testing .....	36
4.6.1	Unit Test.....	36
4.6.2	Integration Testing .....	37
4.6.3	Performance Testing .....	38
4.6.4	Usability Testing.....	38
CHAPTER FIVE	.....	40
CONCLUSION AND RECOMMENDATIONS	.....	40
5.1	Conclusion .....	40
5.2	Recommendations .....	40
REFERENCES	.....	42

APPENDICES.....46  
RESEARCH OUTPUTS.....55

## LIST OF TABLES

Table 1:	The classifications of body weight in adults .....	6
Table 2:	Specifications of Hardware components .....	14
Table 3:	Functional requirements .....	18
Table 4:	Requirements guarded from users during data collection .....	25
Table 5:	Weight measurement unit test .....	36
Table 6:	Weight announcement unit test .....	37
Table 7:	Communication between the scale and android phone unit test .....	37
Table 8:	Scale's performance test results.....	38

## LIST OF FIGURES

Figure 1: Load cell .....	10
Figure 2: HX711 module .....	11
Figure 3: Secure digital card adapter board and secure digital card .....	12
Figure 4: Max98357A inter-integrated sound audio board .....	13
Figure 5: Flowchart of the system.....	20
Figure 6: Results showing users’s awareness about their body weight .....	22
Figure 7: Status of body weight .....	22
Figure 8: Results showing user’s perceptions.....	23
Figure 9: Results showing language suggestions.....	23
Figure 10: Results showing users' challenges.....	24
Figure 11: Block diagram of the design .....	26
Figure 12: Connections between load cells and HX711 module .....	27
Figure 13: Interfacing HX711 Module with Esp8266.....	28
Figure 14: Interfacing Secure Digital card board with Esp8266 .....	28
Figure 15: Interfacing Max98357A module with Esp8266.....	30
Figure 16: Constructed working prototype.....	31
Figure 17: Picture showing a visually impaired person using the scale.....	33
Figure 18: Scale readout on the display .....	34
Figure 19: Scale data sent to the smartphone .....	35
Figure 20: Picture taken during usability testing .....	39

## LIST OF APPENDICES

Appendix 1: Guided Interview Questionnaire for Visually Impaired People .....	46
Appendix 2: Focus Group Discussion Questionnaire .....	48
Appendix 3: Android Codes for a Smartphone to Communicate with a Scale in order to Send Scale Readout to the Smartphone for Remote Access.....	49

## LIST OF ABBREVIATIONS AND SYMBOLS

AAC	Advanced Audio Coding
ADC	Analog to Digital Converter
BCL	Bit clock
BMI	Body Mass Index
CCRBT	Comprehensive Community Based Rehabilitation in Tanzania
CS	chip select
DAC	Digital to Analog Converter
DALY	Disability-Adjusted Life Years
EAC	East African Community
FAT	File Allocation Table
I2C	Inter-Integrated Circuit
I2S	Inter-Integrated Sound
IDE	Integrated Development Environment
kg	Kilogram
LCD	Liquid Crystal Display
LRC	Left/Right Clock
MP3	Moving Picture Expert Group Layer-3 Audio
MVP	Minimum Viable Product
NodeMCU	Node MicroController Unit
OLED	Organic Light-Emitting Diode
SCL	Serial clock
SD	Secure Digital
SDHC	Secure Digital High Capacity
SETI	Technology and Innovation
SPI	Serial Peripheral Interface
TLB	Tanzania League of the Blind
UDP	User Datagram Protocol
WAVE/WAV	Waveform Audio File Format
WHO	World Health Organization
Wi-Fi	Wireless Fidelity
WMA	Windows Media Audio
WS	Word Select
YLL	Years of Life Lost

# CHAPTER ONE

## INTRODUCTION

### 1.1 Background of the Study

Talking weighing scale is a low vision health aid which measure and announces weight of something being measured. Talking scale speaks out the measurements loud to people in a clear voice whereby people does not need to bend themselves to check the scale's measurements on the display (Rehab-Mart, 2021). Existing talking machines announces weight in western languages such as English, Spanish, Greek, German etc. Besides this, the vision of developers was to help people with impaired vision. However, the multitude of talking weighing scale available on the market, no talking weight scale can announce weight in Swahili language. There is always question marks for Swahili speaking people with impaired vision or who do not understand Western languages to interpret results of existing talking scales. And also, most of weighing scales used in rural areas are analog, mechanical and need special skills to interpret their outputs.

The dramatic increase in the prevalence of obesity in most countries has been of great concern globally. This is estimated to be the cause of more than 3.4 million deaths, 4% of Years of Life Lost (YLL), and at least 4% of Disability-Adjusted Life Years (DALYs) all around the world (Shirin *et al.*, 2015). The increase in body mass is associated with higher rates of death driven by comorbidities such as cardiovascular diseases, diabetes, musculoskeletal disorders, cancers, hypertension and infertility (Mahmoud *et al.*, 2017).

Preventing excessive body mass index is important to reduce cardiovascular mortality risk (Gilad *et al.*, 2016). Evidence indicates that even 5–10% weight losses among overweight and obese people can reduce risk factors for these diseases (Dori *et al.*, 2013). Therefore, finding ways to lose even small amounts of body weight can be meaningful.

The most successful weight loss treatments include elements of self-monitoring. One such self-monitoring strategy is more frequency self-weighing as a means to increase self-awareness about weight patterns (Dori *et al.*, 2015). Having bathroom scales at home can allow people to measure and keep track of their body weight. There are numerous bathroom scales which include analog bathroom scales, digital bathroom scales, talking bathroom scales, etc.

Analog balance scales consist of two plates placed at equal distances from a support. One plate carries the object to be measured while other plate carries the predetermined weight and at the



end the weights on both plates should be equal (Engiexpo, 2019). For analog spring scales, if you place some load on the scale, the load pulls a spring. The spring turns the pointer to show the weight of the object being measured. Having all the facts displayed above it is safe to say that existing scales used in marginalized areas cannot be used by Swahili speaking person with visual impairment.

Talking scale is one of emerging speech enabled devices needed by visually impaired people particularly in health sector where regular self-weighing is recommended as a weight loss strategy to avoid excess BMI (Yaguang *et al.*, 2015). Studies suggest that people with disabilities are at increased risk of obesity compared to individuals without chronic conditions. A small number of global reports indicate that between 18.4% and 63% of young people with visual impairment are overweight or obese (Magdalena *et al.*, 2016).

The purpose of this project was to design a talking weighing scale which announces body weight values in Swahili language and provides digital output on the Liquid Crystal Display (LCD) screen which gives the perfect solution for Swahili speaking people with low vision of all levels when monitoring their progress and health to live healthy.

Swahili Speaking Body Weighing, therefore means incorporating speech technology with digital scale to make weighing machines accessible to blind or low vision persons. This thesis provides a design and implementation of Swahili Speaking Body Weighing Scale gadget by using speech technology and strain gauge load cell technology. This weighing system is incorporated within a mobile application and receive information from a weighing scale to speak out the scale measurements. The design and implementation of the Swahili speaking weighing machine was carried out at Nelson Mandela African Institution of Science and Technology, which is a research institution for postgraduate and post-docs studies and research in Science, Engineering, Technology and Innovation (SETI) in Arusha-Tanzania.

## **1.2 Statement of the Problem**

Research has estimated that eighty to eighty-five percent of our perception, learning, cognition and activities are mediated through vision (Politzer, 2017). The millions of blind people worldwide are at a major disadvantage compared to sighted individuals. For example, using bathroom scale to weigh themselves, using kitchen scale to weigh ingredients when cooking etc., is a simple set of tasks for a sighted person. For a blind person, however, these tasks present a series of challenges. Controlling body weight, even a civilized one, is almost impossible for an individual with a severe visual impairment without some kind of assistive tool. Many blind

people from western countries make use of talking scales, which allow them to do self-weighing and avoid excess body weight and then live healthier.

Everyone wants to be healthier and happier but if one has low vision, it can be frustrating when you cannot see the scale readout. Little is known about how visually impaired Swahili speaking community can do regular self-weighing as it is recommended for all people to improve the adaptation of weight control to stick to healthy habits in long run.

Talking bathroom scales become necessary tool as visually impaired people who do not have access to bathroom scales do not often bother to check their body weight and this can be harmful to their health. However, existing talking scales do not provide any assistance to Swahili speaking visually impaired community. Most speaking weight scales available on the market announce weight in western languages such as English, Spanish, Greek and German (Rehab-Mart, 2020).

### **1.3 Rationale of the Study**

A report from Comprehensive Community Based Rehabilitation in Tanzania (CCRBRT) show that at least 1.1 million people are visually impaired and 33 000 are blind in Tanzania, with an average household size of five, at least 4.7 million people are directly affected by blindness and visual impairment in Tanzania (CCRBRT, 2017). People with visual impairment face serious challenges in doing regular self-weighing as recommended to all people for weight control to live health life. Furthermore, these individual especially in Africa receive little consideration when new technology is introduced as many advanced technologies are limited to developed countries. On the other hand, most of the weighing scales used in marginalized areas in Tanzania are mechanical and analogue such as spring scale, balance scale which need special skills and also take time to interpret the results. However, mechanical weighing machines need to be set to zero and recalibrated manually. Therefore, Swahili speaking people with visual impairments cannot be able to use these existing weighing scales. With a speaking weighing machine which announces weight in Swahili, Swahili speaking community in Eastern African region with visual impairment can be assisted to live healthy by controlling their body weight as Swahili is the common language within the Eastern African region (East African Community Secretariat, 2017). Just like other low vision aids, this talking body weighing scale with weight measurements of up to 200 kilograms, is functional, durable, accurate and easy to use while ensuring that one gets the right measurements.

The usefulness of this gadget is further justified by its applicability in other environments like Kitchen scale for measuring food, in shops or supermarkets as well as for people who have mobility limitations which prevents them to view the scale readout from the standing angle.

## **1.4 Project Objectives**

### **1.4.1 General Objective**

To develop a Swahili speaking weighing scale which measures, displays digital output and announces weight in Swahili language while the announced weight is sent to the smartphone.

### **1.4.2 Specific Objectives**

- (i) To analyze the requirements for Swahili speaking body weighing scale for blind people in Tanzania.
- (ii) To design and implement a Swahili speaking weighing machine.
- (iii) To test the developed weighing machine.

## **1.5 Project Questions**

- (i) What are the requirements for Swahili speaking body weighing scale for blind people in Tanzania?
- (ii) How will the body weighing scale be designed and functioning?
- (iii) How will its performance be recognized?

## **1.6 Significance of the Study**

Although the applicability of this study is going to be useful in other environments like Kitchen scale for measuring food, in shops or supermarkets as well as for people who have mobility limitations which prevents them to view the scale readout from the standing angle, the main importance has been focused on the followings:

- (i) To increase awareness of people to measure their weights, especially the visually impaired ones.
- (ii) To help impaired people know their weight and hence controlling their body weights.

- (iii) To encourage the development of technology in Swahili language.
- (iv) To emphasis people to live healthy by controlling their weights.

### **1.7 Delineation of the Study**

This project designed a talking weighing scale which announces body weight values in Swahili language which provides digital output on the Liquid Crystal Display (LCD) screen, gives the perfect solution for Swahili speaking people with low vision of all levels when monitoring their progress and health to live healthy. This weighing system is incorporated within a mobile application and receive information from a weighing scale to speak out the scale measurements.

## CHAPTER TWO

### LITERATURE

#### 2.1 An Overview of Bodyweight and Body Mass Index

Body weight, and its extreme of obesity, has emerged as a major public health concern (Ruijun *et al.*, 2013). Excess body weight is one of the leading causes of morbidity and mortality, and it is increasing exponentially worldwide (Eltagi *et al.*, 2015). Body weight that is greater than what is considered healthy weight for a given height is described as overweight or obesity (Saeed *et al.*, 2020). The BMI is a simple tool commonly used to classify overweight and obesity in adults (Adela *et al.*, 2015). The BMI is calculated as weight in kilograms divided by height in meters squared ( $\text{kg/m}^2$ ) (Katherine *et al.*, 2012). Table 1 which ranges from underweight to obesity shows the classifications of body weight in adults.

**Table 1: The classifications of body weight in adults**

Age	Indicator	Underweight range	Healthy weight range	Overweight range	Obesity range
$\geq 20$ years	BMI ( $\text{kg/m}^2$ )	$< 18.5$	18.5 to $< 25$	25.0 to $< 30$	$\geq 30.0$

The need for people to constantly control their body weight cannot be overdrawn. Today, the number of patients with obesity is growing at an alarming rate (Saeed *et al.*, 2020). Overweight and obese individuals are at increased risk for many diseases and health conditions, including the high blood pressure, diabetes, heart Stroke etc (Fruh, 2017). As these diseases are excess body weight related, having bathroom scale at home can allow people to check and keep track of their body weight hence preventing excess BMI. There are numerous bathroom scales which include analog bathroom scales, digital bathroom scales and talking bathroom scales.

#### 2.2 Analog Scales

Analog weighing machines rely on springs to measure people's body weight. These scales are mechanized in nature. They do not need a power source to operate. However, it needs to be set to zero and recalibrated manually before being used. Due to the fact that analog scales' springs might suffer from gradual wear and tear, and can provide inaccurate readings over time. Thus analog scales are known to be less accurate and less precise (Meredith *et al.*, 2013).

#### 2.3 Digital Bathroom Scales

Digital scales typically operate by the use of sensors. The sensor used in digital weighing scale which gives out digital output is strain gauge load cell. When the load is placed on the scale,

these gauges are stretched, the force being sensed deforms a strain gauge. The strain gauge measures the deformation (strain) as an electrical signal then the scale sends the measured signal to a Digital to Analog Converter (ADC) to digitize the signal, producing a readable number on the scale. Thus making digital weight scales accurate and errorless weight measurements (Kunal *et al.*, 2013).

## **2.4 Talking Bathroom Scales**

Talking scale is one of emerging speech enabled devices needed by visually impaired people particularly in health sector where regular self-weighing is recommended as a weight loss strategy to avoid excess BMI (Yaguang *et al.*, 2015). Studies suggest that people with disabilities are at increased risk of obesity compared to individuals without chronic conditions. A small number of global reports indicate that between 18.4% and 63% of young people with visual impairment are overweight or obese (Magdalena *et al.*, 2016).

Talking scale works like other digital bathroom scale with additional voice feature to speak out the results in order to assist people who find it difficult to read the display. Many talking scales have a language option for English, German, French or Spanish (Rehab-Mart, 2020). In the design of Talking scale, the main hardware used in the processes includes load cells sometimes called weight sensors. These are transducers which convert mechanical energy into electrical energy (voltage level) whereby the produced electrical signal is directly proportional to the weights of objects being measured (Load Cell Central, 2020). This voltage level filtered and converted into digital data using 24-bit sigma-delta Analog to digital converters (ADC) and processed by embedded hardware with specific microprocessor or microcontroller to display digital output of measured weight on LCD screen and then use text to speech technology to announce measured weight verbally in either pound or kilogram using languages such as English, French, Spanish, Greek, German.

## **2.5 Swahili Speaking Body Weight Scale**

Swahili Speaking Body Weighing scale, it is just like other bathroom talking scale however it is based on Swahili language and can send scale data to an android smartphone. When used for voice measurements, audio files containing voices of weights are stored on Secure Digital (SD) card. These files are then called by the microcontroller and announce weight accordingly on your smartphone or loudspeaker. The main disadvantage is that the scale may need to be always connected to the power for it to operate.

Typically, Swahili Speaking Body Weight Scale uses stored audio files on SD card rather than text to speech technology used in bathroom scales. The use of text to speech technology in existing talking bathroom scales implies the limitation in announcing weight in Swahili language given the fact that there is no library to convert text numbers into Swahili language even when numbers are written in Swahili, if one uses text to speech, they are pronounced in accent of White people reducing the quality as a result of using recorded numbers in Original Swahili.

To embed Swahili language in talking weight scale, the SD card was used to store audio data of recorded numbers in Swahili language. Audios are used to map the measured weight into a sequence voices patterns accordingly. For instance, if the scale displays 155 Kg, this output will be mapped into a sequence of 6 audio files to be announced verbally in Swahili. i.e. audio files of: “Kilo” “miya” “moja” “hamsini” “na” “tanu”.

This is done by using a recursive function which return an array that contains the place value of all the digits present in the integer number of the displayed weight. The array has 3 dimensions whereby index 0 holds units, index 1 holds tens and index 2 holds hundreds. Once the displayed number is converted into hundreds, tens and units, the corresponding audios are retrieved from SD card and concatenated.

Serial Peripheral Interface (SPI) offers a communication between SD card and microcontroller. The integrated circuit within the microcontroller offers the necessary intelligence circuitry for computation purposes, for instance, the circuitry computes the data from weight sensors (load cells). Based on the output produced, it then calls the corresponding audio file from SD card. The HX711 module serves the purpose of amplifying the low output produced by weight sensors at the same time servers as Analog to Digital Converter (ADC) and sends sensor’s data to the microcontroller.

## **2.6 Purpose and Motivation**

The main purpose of this device is to offer Swahili speaking visually impaired people an efficient and seamless means of which to control their weight for their healthy life, increase awareness of people to measure their weights and at the same time embrace the development of technology in Swahili language. This weighing gadget also aims to provide convenience to people from marginalized area in Tanzania while addressing the drawbacks of existing weighing machines which are being used in rural areas, which are specifically:

- (i) Citizens from developing countries receive little consideration when new technology is introduced as many advanced technologies are limited to developed countries. Especially from the fact that among the existing talking scale on the market, none of them can announce weight in Swahili language which is the common local language in EAC. This form of ignorance is on the rise and will continue to get even worse if a solution is not found to encourage the development of technologies in our languages.
- (ii) Most of weighing scales used in marginalized areas in Tanzania are traditional and mechanical such as spring scale, balance scale which need special skills and also take time to interpret the scale measurements. Mechanical scales are known to be less accurate and less precise. Mechanical scales also need to be recalibrated manually hence the overall consequence of this is the ignorance in weight control which contribute to living unhealthy life. Therefore, these scales need to be digitized with integration of voice feature to provide access of weighing machine to individuals of all citizens from marginalized areas.

And finally, majority of population in urban areas are individuals with a lot of responsibilities and do not need to be present to view the scale readout from the standing angle. There is also a good number of individuals who have mobility limitations and depend on others to assist them to read the scale measurements, something of which is not always very reliable (Andrea *et al.*, 2013). This is intended to be solved by the integration of a talking weighing system with a mobile application to speak out the scale measurements on a smartphone. The usefulness of this gadget is further justified by its applicability in other fields like Kitchen scale for measuring ingredients when cooking, in grocery stores and many more.



## CHAPTER THREE

### MATERIALS AND METHODS

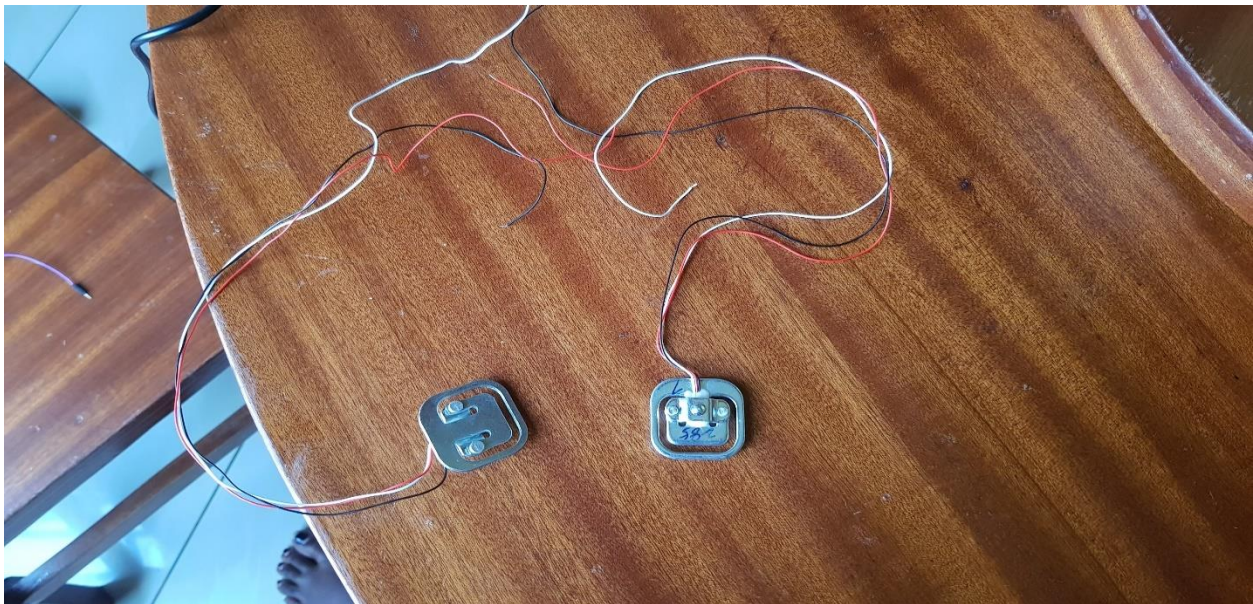
#### 3.1 Overview

This section describes the various materials, tools and method that have been used to develop Swahili Speaking Body Weight Scale. This section also elaborates the steps which have been taken to achieve the main objective of this project. It also describes the data collection and data preparation methods as well as the study area.

#### 3.2 Materials

##### 3.2.1 Load Cell

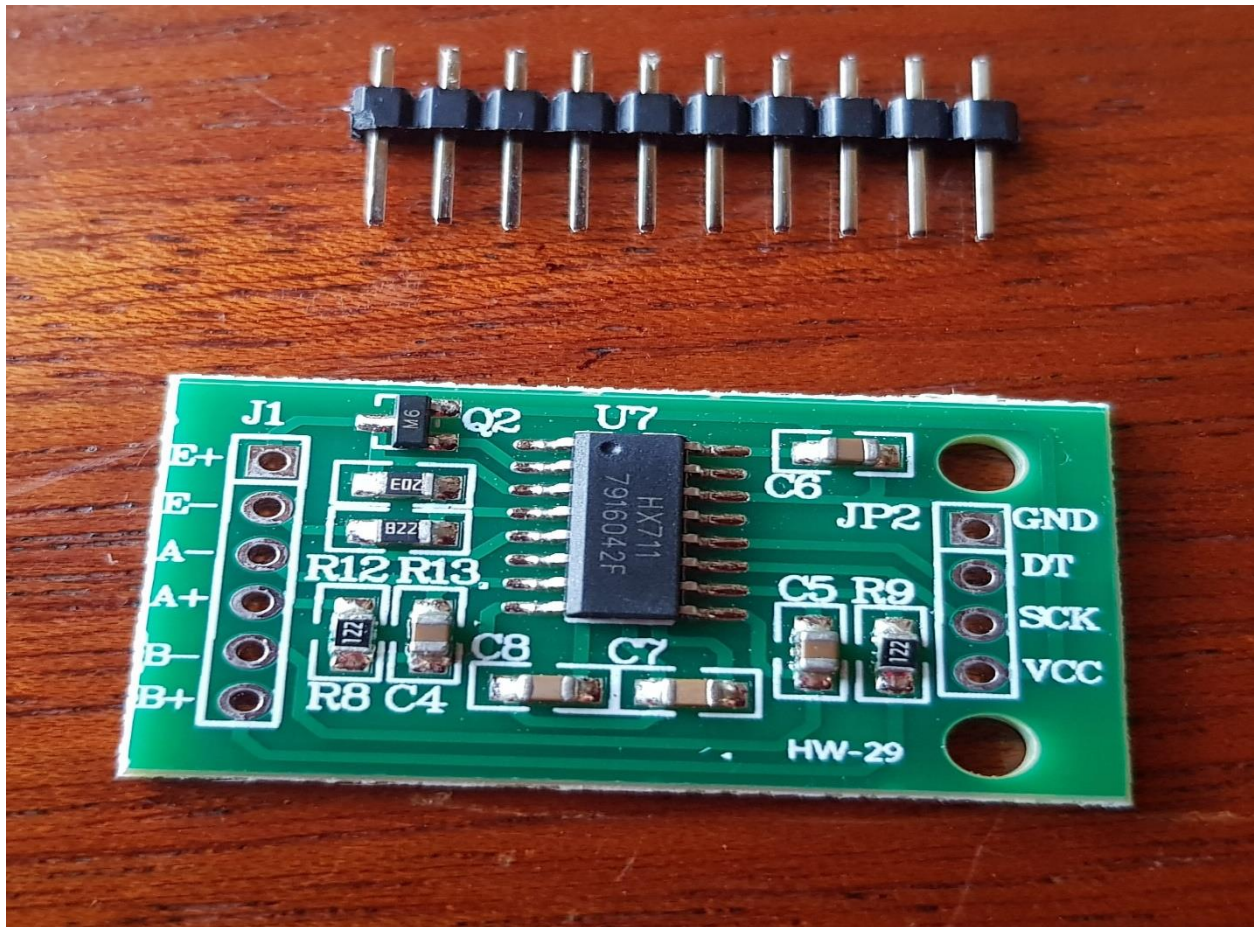
This is a weight sensor that was used in the development of Swahili Speaking Body Weight Scale. The type of load cell used is strain gauge load cell. It was best suited for it is specialized for weighing devices, given that it has better accuracy and precision. Strain gauge load cell works by changing force/weight of objects being measured into electrical resistance whereby the produced electrical resistance is proportional to the stress/strain placed on the cell making it easy to calibrate into an accurate measurement (Kamlesh, 2013). Figure 1 shows Load cells used as weight sensors.



**Figure 1: Load cell**

### 3.2.2 HX711

This module is a 24-bit ADC integrated with an amplifier (Avia Semiconductor, 2018). Since the used load cells produce a weak analog signal which cannot be processed by the control unit. The HX711 was best suited for it is specialized for weight scales. The HX711 is used to amplify the load cell's weak signal output and produce standard digital values which can be processed by the microcontroller. Given that also microcontrollers process digital signals only. Figure 2 shows



HX711 module used as ADC.

**Figure 2: HX711 module**

### 3.2.3 Esp8266 NodeMCU

This was used as a processing unit. A voltage level filtered and converted by HX711 module is sent to Esp8266 NodeMCU over serial communication input port for further processes. The received signal is then computed by Esp8266 NodeMCU to calculate the measured weight and display the measured weight on the display. The Esp8266 NodeMCU uses its SPI interface to communicate with SD card while retrieving audio files which match with the displayed weight.



Then over Inter-Integrated Sound (I2S) port Esp8266 NodeMCU forwards the retrieved audios to the amplifier then to the loudspeaker.

The Esp8266 NodeMCU was best suited for it is made with Wi-Fi functionalities and suitable for audio based applications (Espressif Systems, 2015). The Esp8266 does not have SD card slot. Therefore, micro SD card adapter module with Secure Digital High Capacity (SDHC) card was used to be interface with Esp8266 NodeMCU over SPI interface. Secure Digital (SD) Card is a low cost non-volatile memory card used in mobile devices to store data and to enable the transfer of data between devices. The 4GB micro SDHC card was used to store WAVE files and formatted as FAT32. The SD card consists of Memory core and SD card controller as its basic semiconductor sections. Memory core is flash memory where file system is located after formatting SD card, and also file of data is saved on this region. The SD controller allows communication between memory core with external devices such as microcontroller (Ababei, 2013). Figure 3 shows SD card Board with SD card used as storage component.



**Figure 3: Secure digital card adapter board and secure digital card**

### **3.2.4 Max98357A Inter-Integrated Sound Audio Board**

This is a DAC with a built-in amplifier that decodes the Inter-Integrated Sound (I2S) signal in an analog signal and also amplifies the signal before being forwarded to the speaker. This audio amplifier was selected as it has I2S interface which is compatible with Esp8266 NodeMCU. Figure 4 shows Max98357A I2S audio board used as audio amplifier.

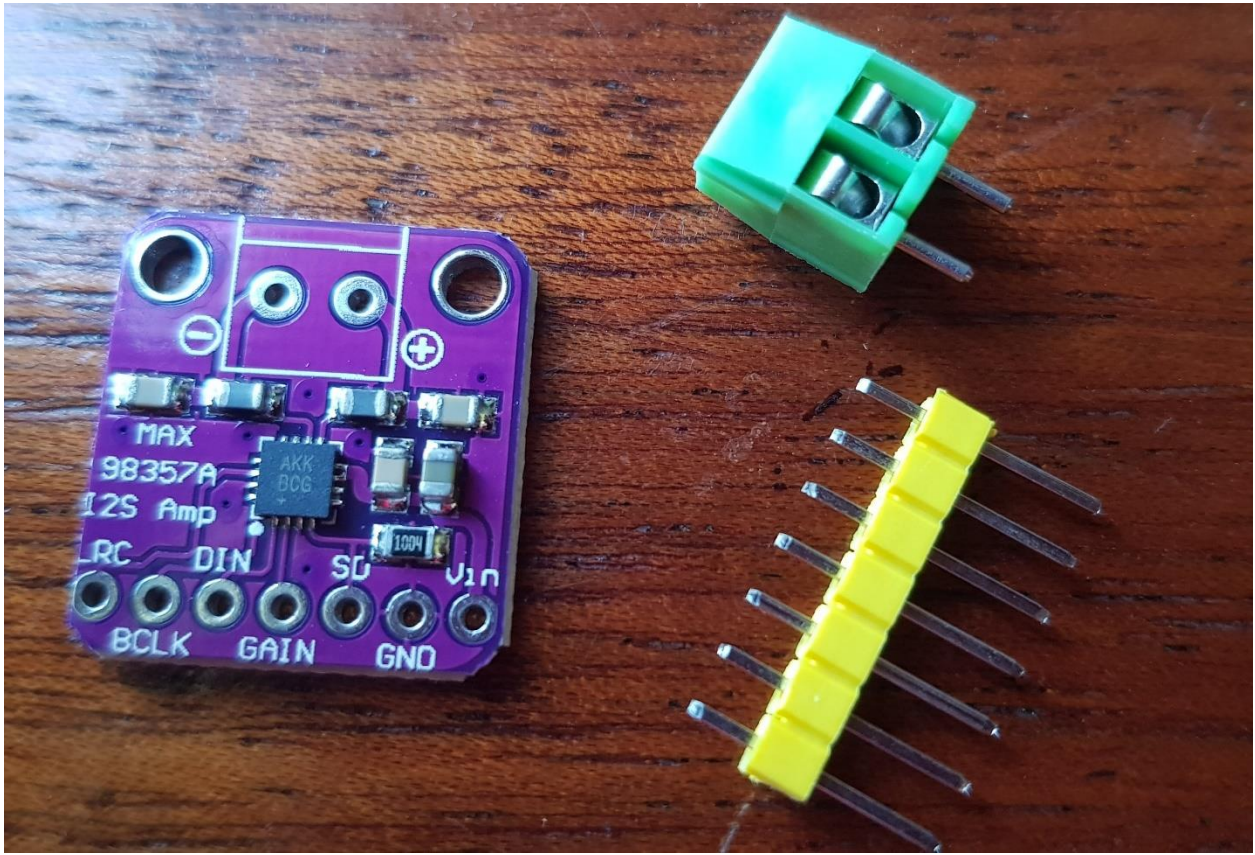


Figure 4: Max98357A inter-integrated sound audio board

Further specifications of the different materials used are as shown in the Table 2.

**Table 2: Specifications of Hardware components**

		Material Name				
<b>Feature</b>	Load cell	HX711 module	ESP8266	SD card	Max98357 A I2S DAC,	Oled1.3 inches
<b>Type</b>	Weight sensor	ADC, Weigh scale amplifier	Microcontroller	Micro SDHC card	Class D audio amplifier	LCD Display
<b>Operating Voltage</b>		2.6~5.5V	3.0~3.6V	3.3V	2.7V~5.5V	3.3V~5.5V
<b>Capacity</b>	50 Kgs Maximum	<ul style="list-style-type: none"> <li>• 24-bit ADC</li> <li>• Max gain=128</li> </ul>	<ul style="list-style-type: none"> <li>• CPU clock speed = 80 MHz with a Max value of 160MHz.</li> <li>• RAM size &lt; 36kB</li> </ul>	32 GB and speeds up to 25 MB/s.	Gain is between 3dB and 15dB	1.3 inches with 128x64 Resolution
<b>Communication Interface used</b>	NA	Serial Interface		SPI	I2S	Inter-Integrated Circuit (I2C)
<b>Working Frequency</b>		80 Hz	26MHz to 52MHz.	50MHz.	Sampling rate: from 8kHz to 96kHz	
<b>Operation Temp. Range</b>	0--+50°C	-40 ~ +85°C	-40°~125°	-25°C to +85°C	-40°C to +85°C	-30 to 70

### **3.3 Software and Libraries**

#### **3.3.1 Arduino Integrated Development Environment**

Arduino is an open source software whereby it allows programmers to program boards the way they want. It was the best suit as Arduino is compatible with ESP8260 board. This IDE was used to program ESP8260 on how it will compute signals from HX711 modules and matches the output with wave files stored on SD card.

#### **3.3.2 HX711 Library**

This is an Arduino library to interface with HX711 ADC for reading load cells. It also contains calibration function which helped to calculate a scale's calibration index (value).

#### **3.3.3 EEPROM**

This library was used Arduino codes to save calibration parameters or calibration index of the scale.

#### **3.3.4 ESP8260 Wi-Fi**

This library was used to enable ESP8260 nodemcu in wireless communication.

#### **3.3.5 WIFI User Datagram Protocol**

This was used to allow ESP8260 nodemcu to use UDP functions when it is sending data to the smartphone.

#### **3.3.6 Oled**

This library was used for display and uses I2C protocol to interface ESP8260 microcontroller with Oled display.

#### **3.3.7 FAT32**

File systems are the standards for organizing data on the storage devices. The FAT32 was used as file system. It was selected as SDHC card support FAT32 as File system.

### **3.3.8 Android Studio**

This was the Integrated Development Environment (IDE) that was used in the development of the mobile application. It was best suited for it is specialized for android applications development, given that most mobile phones run on android operating system, made android studio the IDE of choice. Given that also it has good online support.

### **3.3.9 WAVE Files**

The WAVE is an audio file format. Collecting audio files of WAVE file format was the best choice because WAVE files are uncompressed and lossless meaning that no data is lost during saving or encoding process (Headphonesty, 2020). It is also suitable for audio loops as our audio files will be played over and over again as long as the device is operating (Gilles, 2011).

## **3.4 Methods**

This project is divided into two major parts. On the front-end of the design, sensors are used to capture physical parameters such as weight and the captured values will be mapped onto a sequence of voice patterns. The back-end of the design consists of transferring a sequence of voice patterns to a loudspeaker, where the voice patterns are stored on an SD card as .WAVE files. voice patterns are then transferred to the amplifier and forwarded to the loudspeaker.

### **3.4.1 Study Area**

The focus of this project is the Swahili speaking people particularly visually impaired people in Tanzania. The first reason of choosing this area is that people with visual impairment face serious challenges to do regular self-weighing as recommended to all people to live healthy life. Besides this, these individuals especially in Africa receive little consideration when new technology is introduced. Given the fact that none of the existing talking weight scales can speak in Swahili. The second reason is that most of the weighing scales used in marginalized areas in Tanzania are traditional and need special skills to interpret the weight scale measurements which implies that person with visual impairment is not able to use these kinds of scales.

### **3.4.2 Sample Size and Technique**

In this project, the target population sample was selected to determine the extent of the problem and identify the requirements needed to develop a Swahili Speaking Weight Scale for blind people. To get this done, a non-probability purposeful sampling technique was used to collect information from individuals who have vision impairment and who are blind. This technique was

used because it does not attempt to select a random sample from the population but instead uses subjective methods to select the sample size so that the survey data is collected from respondents who are expected to be the primary users of the proposed solution (Palinkas *et al.*, 2015). A total number of 50 respondents were involved in this study, from which 25 were from Ngorongoro and 20 were from Dare es salaam in the centers for blind people. Also, five sighted staff from TLB were involved in data collection, device design and device testing.

### **3.4.3 Data Collection Methods**

This was done at the initial stage as one of the methods of data collection. The process involved several techniques which includes interviews, discussion and observation.

#### **(i) Guided Interview**

Guided interview questions were posed to blind people and visually impaired ones to collect information about their experience on how they use weight scales and how they control their body weight. Furthermore, the study also investigated whether embedding Swahili audios into weighing machines will improve regular self-weighing in Swahili speaking community (Appendix 1). Since sighted people were few (only 5 staff members) interviews technique was the best method that could be used to collect data from these groups.

#### **(ii) Focus Group Discussion**

The focus group discussion was conducted with the sighted people who assist blind people in their daily activities. The aim was to find out the current level of awareness for blind people to control their weight, means used to monitor their body. Another discussion was based on the challenges that blind community face while using weighing machines (Appendix 2).

### **3.4.4 Data Analysis Method**

In this study data collected from interviews and group discussions were organized and analyzed using thematic qualitative analysis method in order to identify the proposed solution requirements. Finally, the findings of the study were then reported and came up with effective methods on how to develop the proposed solution. Thematic method was used because the main goal was to find out about people's opinions, views and experience in accessing weighing machines for Swahili speakers visually impaired ones (Michelle *et al.*, 2020).



### 3.4.5 Development method -Minimum Viable Product

This is the continuous improvement of a viable prototype. The design, development, implementation and testing were made. Then with each complete part, improvement was made on some aspects that have been found wanting. Improvements were made putting into account the user feedback until the final product which incorporated an acceptable feature of the user requirements.

### 3.4.6 System Design

#### (i) Functional Requirements

Functional Requirements are summarized in Table 3.

**Table 3: Functional requirements**

---

S/N	Requirement Description
1	User should be able to power the device
2	User should be able to setup a Wi-Fi hotspot whose credentials are configured with the scale. Wi-Fi credential include: Network name, and its password
3	The weight scale should be able to identify and create a broadcast communication with authorized smartphones
4	The scale should be able to calibrate itself automatically and then display/announce welcome note (KARIBU) when the scale readout is 0 Kg
5	User should be able to stand onto the scale' s platform (or be able to put object to be measured onto the scale' s platform)
6	The device should measure and display the weight scale measurements on LCD screen
7	The system should broadcast weight scale measurements to the mobile application
8	The scale should announce the weight scale measurements when the scale reaches the steady state where weight is no longer increasing

---

#### (ii) Non-Functional Requirements

##### *Provide Seamless Operation*

This is to mean that a user should not feel the pressure of using the device and it should be very easy to use.

### ***High Speed of Operation***

User should not waste time waiting for the device to display and announce their weight. It takes 5 seconds to announce the scale measurements. This delay is due to the time the scale takes to capture data and then retrieve the corresponding audio files from SD card and send data to the android application.

### ***High system Integrity***

There should be no loss or corruption of information the system holds.

### ***Easy Maintainability***

Updates and improvements on the system should be easily achievable.

### ***Increase Convenience***

It should be very convenient and seamless to use.

### ***Accuracy***

The device should accurately measure and announce weight accurately.

### ***Friendly to Users***

The announcements should be made in a warm, friendly manner and clear voice.

### 3.4.7 Architectural Design

Flowchart diagram of the system is shown in Fig. 5.

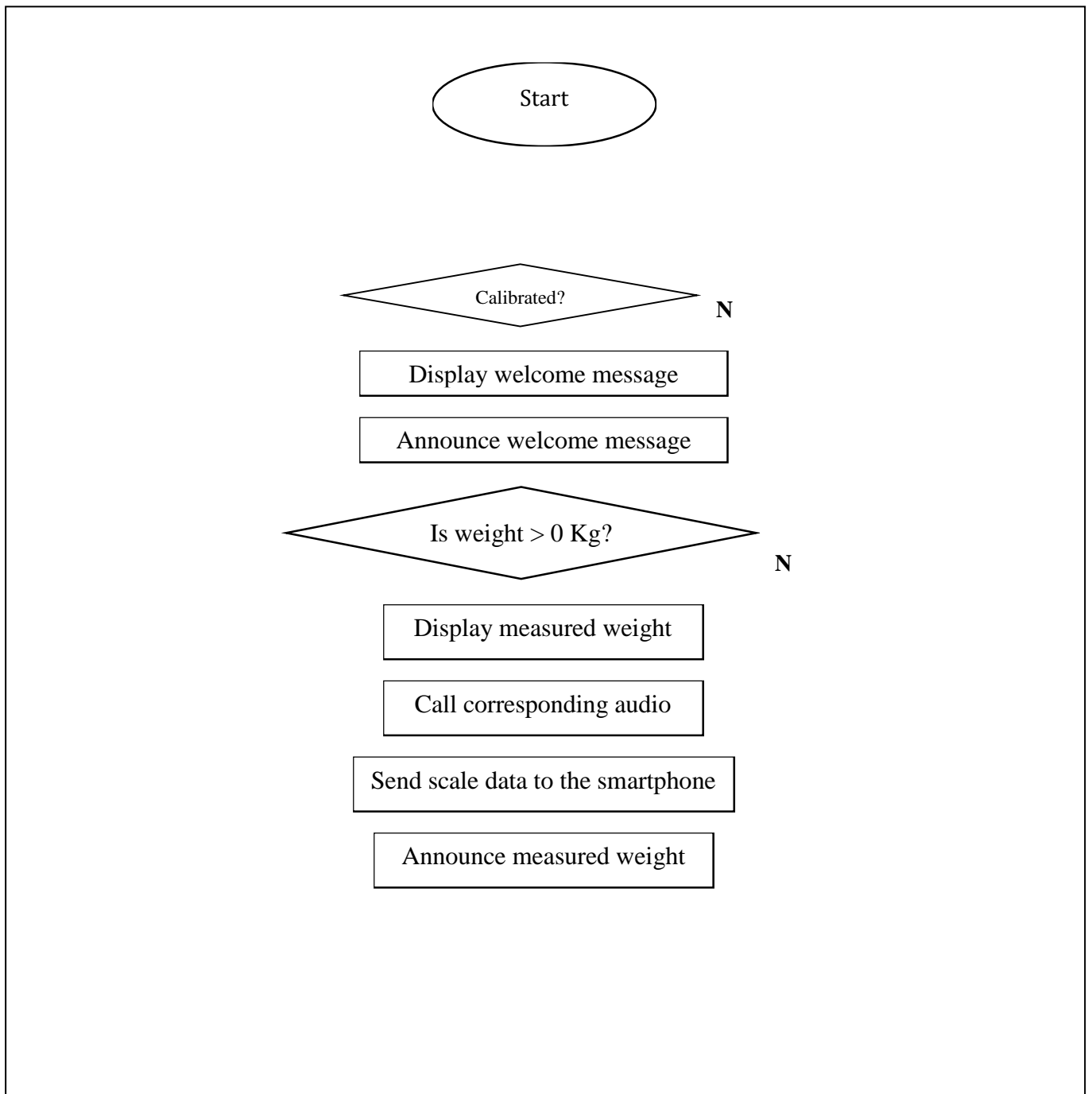
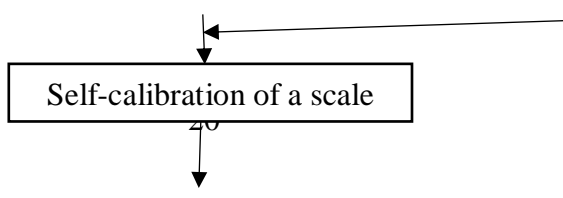


Figure 5: Flowchart of the system



## CHAPTER FOUR

### RESULTS AND DISCUSSION

#### 4.1 Overview

This chapter discusses findings from data collected in the study area, requirements formulation, device designing and development as well as device operation. The chapter also discusses the correspondence between findings and project objectives. The first objective was to analyze requirements for developing a Swahili speaking body weight scale for blind people. This also includes users' awareness and their perception regarding the proposed gadget. The second objective was to design and implement a Swahili speaking weight scale for Swahili speaking visually impaired community. The third objective was to test and validate the developed device.

##### 4.1.1 Existing Talking Bathroom Scales

Talking bathroom scale known as body weight scale is useful type of assistive technology to assist visually impaired community in maintaining a healthy body weight. Talking bathroom scales announce weight of someone being measured in either pounds or kilograms/grams (Everyday Sight, 2020). The announced weight is also shown on LCD display in digits. Talking bathroom scales use text to speech technology by converting displayed digits into voice to be announced verbally in natural language. Many of talking scales have a language option for English, German, French or Spanish (Rehab-Mart, 2020).

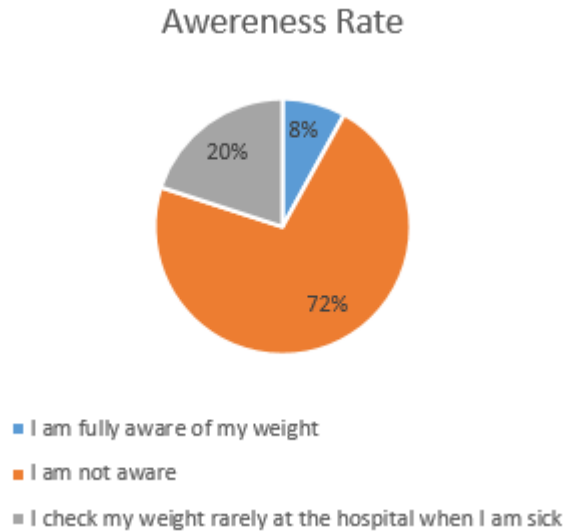
Interviews and group discussions were done to get information on how people with visual impairments in Tanzania use bathroom scales. The study uncovered some weaknesses in the existing talking bathroom scales whereby no talking scale can announce weight in Swahili to assist Swahili speakers. The use of text to speech technology in existing talking bathroom scales implies the limitation in announcing weight in Swahili language given the fact that there is no library of text to speech for Swahili language. Therefore, it is safe to say that existing talking bathroom scales do not provide any assistance to Swahili speaking visually impaired community and Swahili speakers at large.

##### 4.1.2 Findings from Users in the Case study

User data were collected to determine the extent of the problem and whether the proposed solution would be a relevant solution. A total of 50 respondents participated in this study.

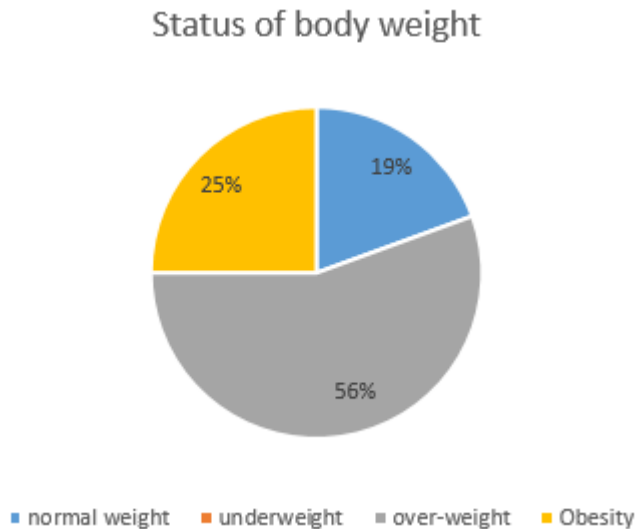
**(i) Users' Awareness about their Body Weight Track Behavior**

Out of 50 respondents, only 8% were fully aware of their body weight. The 20% stated that they only check weight only when they are sick when at the hospital while the majority of the respondents do not have a clue about information regarding their body weight behavior as shown in Fig. 6.



**Figure 6: Results showing users's awareness about their body weight**

The study also uncovered that among people who were not aware of their body weight, the majority of them were overweight. Out of 36 people who were not aware of their body weight, 20 of them were over-weight and 9 of them were obese as shown in Fig. 7.

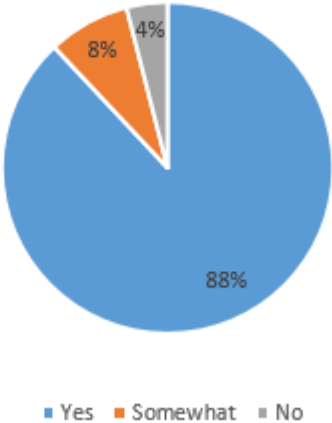


**Figure 7: Status of body weight**

**(ii) User' Perception on the Need for having Speaking Weight Scale**

Of the 50 respondents, 88% agreed that it would be helpful to have a speaking weighing scale. while 4% disagreed on the matter. Figure 8 summarizes this information.

Perception of need of Talking Scale

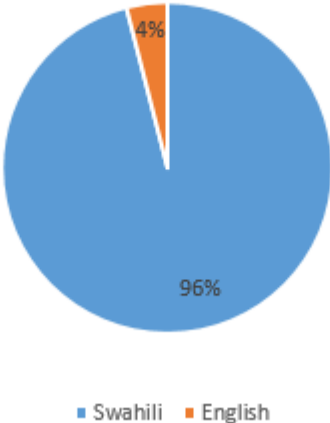


**Figure 8: Results showing user's perceptions**

**(iii) User' Suggestions about the Language to be used for Weight Announcement**

The majority of the respondents suggested Swahili language to be used in weight announcement as shown in Fig. 9.

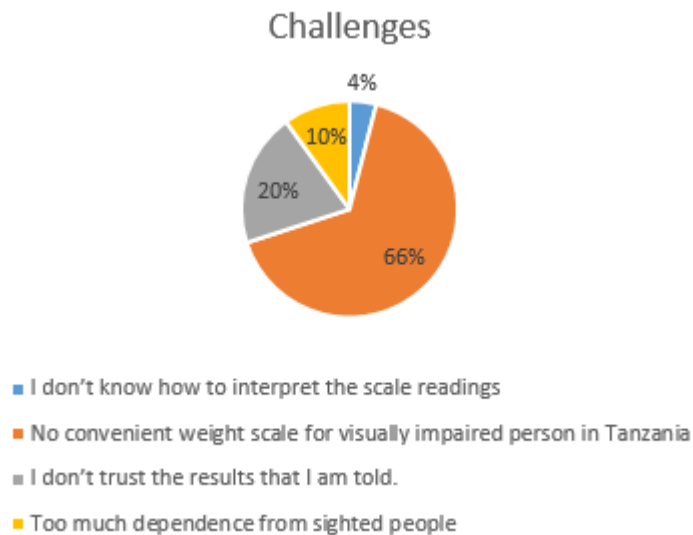
Preferred Language



**Figure 9: Results showing language suggestions**

#### (iv) User' Challenges

The User's challenges which prevent them from controlling their weight regularly are summarized in Fig. 10.



**Figure 10: Results showing users' challenges**

#### (v) Users' Recommendations on the System Requirements

In this study, requirements were partly collected from end users, who are the potential beneficiaries of the proposed device. Table 4 shows the requirements collected from respondents, whereas it appeared that, after requirements analysis, the majority of respondents preferred the device to be able to do auto self-calibration, weight announcements to be in Swahili and send scale measurements to the smartphone. Table 4 shows users' recommendations on the system requirements.

**Table 4: Requirements guarded from users during data collection**

<b>Requirements</b>	<b>Respondents</b>
User should not feel the pressure of using the device and it should be very easy to use	35
User should not waste time waiting for the device to display and announce their weight	30
The scale should be able to calibrate itself automatically and announce welcome note when it is ready	43
The device should accurately measure and announce weigh accurately	45
The device should send scale measurements to the smartphone	7
The announcements should be made in a warm, friendly manner and clear voice and the language should be Swahili	48

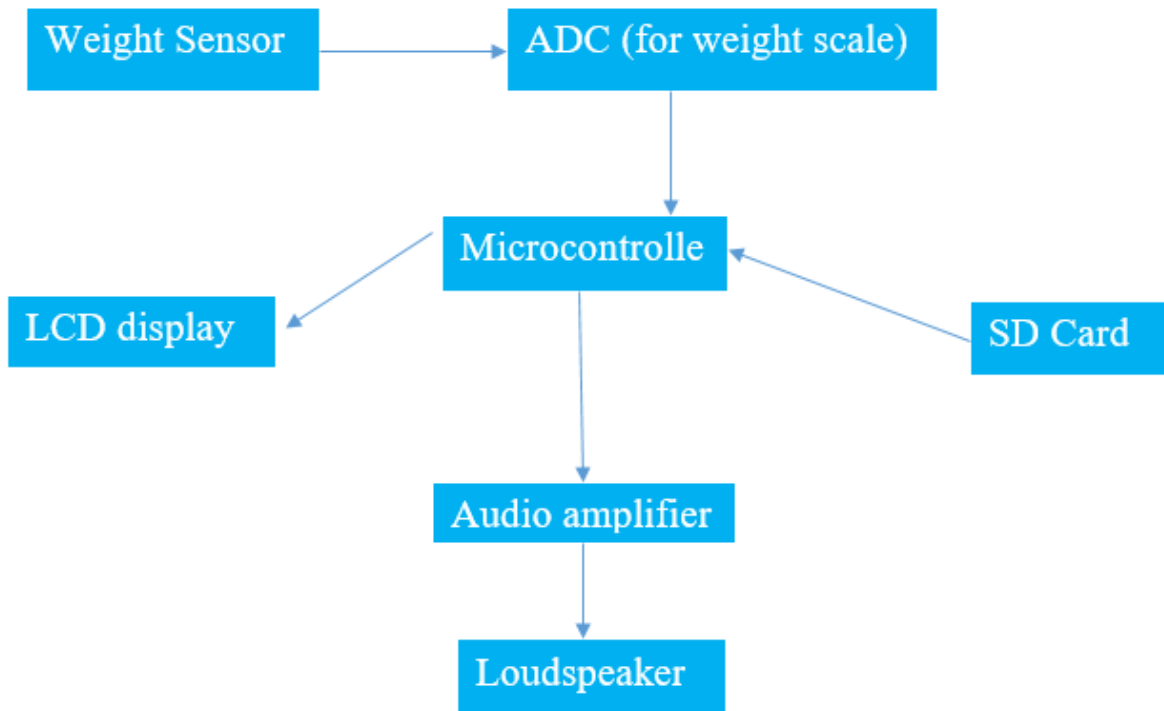
## **4.2 Process of Implementation**

### **4.2.1 Prototype - Design**

The first part of the design was to do the physical connections among different hardware components which were used. The design shows how the different hardware used communicate with each other.



Block diagram of the entire design is shown in Fig. 11.



**Figure 11: Block diagram of the design**

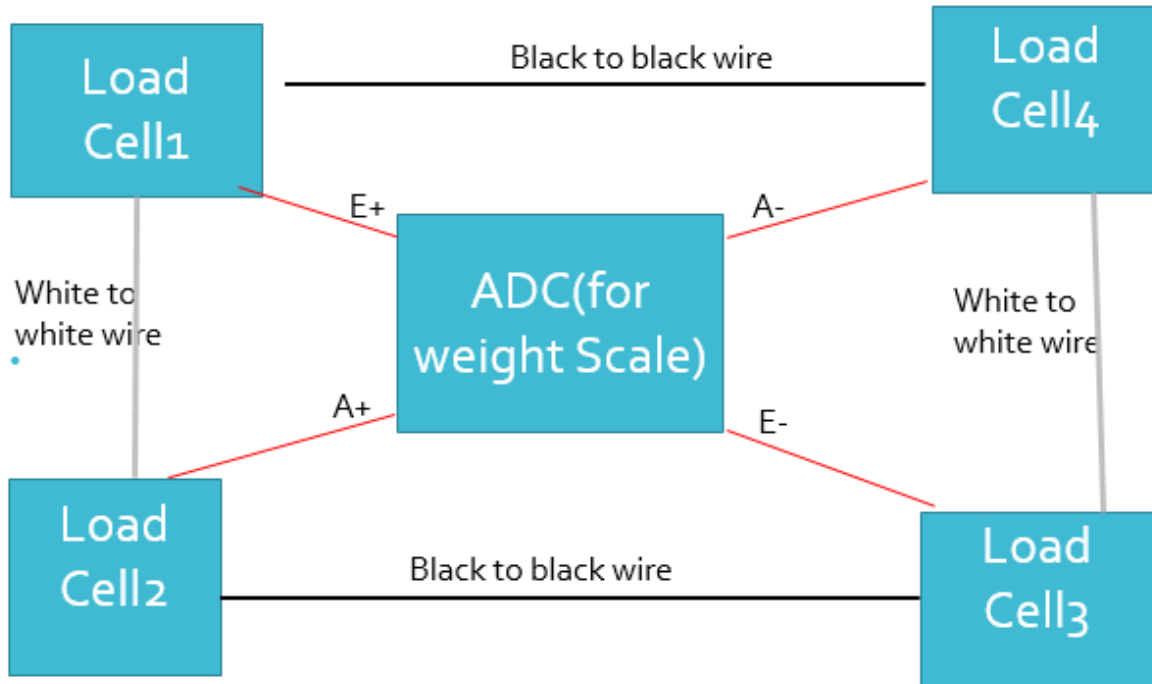
#### **4.2.2 The Connection between Load Cells and HX711 Module**

The connection between Load cells and HX711 module is as follows:

- (i) For a single scale, 4 load cells were used as weight sensors. Each load cell has 3 wires which are: White wire, black wire and red wire. Each load cell measures up to 50 Kgs maximum.
- (ii) All the 4 load cells are connected in a loop by connecting together white to white cables and black to black cables the neighboring load cells.
- (iii) One diagonal red wires are used as power wires. They are connected to E+ and E- output pins of HX711 amplifier module.
- (iv) E is the excitation voltage, E+ is the excitation positive and E- is the excitation ground.
- (v) Since HX711 module is supplied by the microcontroller itself and also E+ and E- are supplied through the circuit internally, meaning that we don't need external power to generate E+ and E- signals.

- (vi) The other diagonal red wires are used to take measurements from sensors (load cells). They are connected to A+ and A- input pins of HX711 amplifier module.
- (vii) A+ and A- are sensor values. Since all 4 Load cells are connected in a loop then A+ and A- takes the measurements from all the 4 sensors and send to HX711 module's inputs.
- (viii) Black wire is used as ground wire.

Figure 12 shows the connections between 4 load cells and HX711 module.



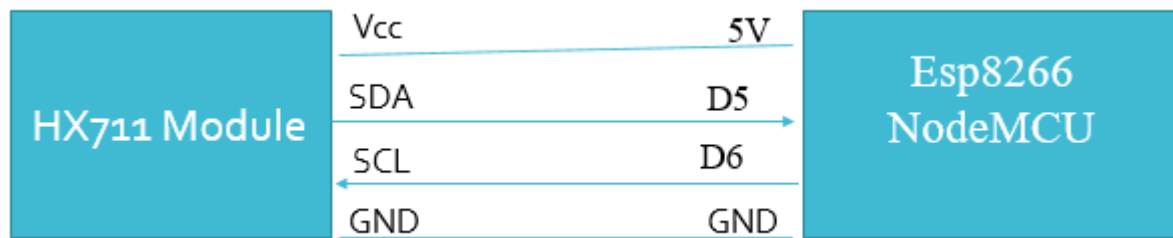
**Figure 12: Connections between load cells and HX711 module**

#### 4.2.3 Interfacing HX711 Module with Esp8266 NodeMCU over Serial Interface

These include the following:

- (i) Connect Vcc pin of HX711 to 5V of Esp8266 NodeMCU
- (ii) Connect GND pin of HX711 to ground pin of Esp8266 NodeMCU
- (iii) Connect HX711 amplifier's data pin to D5 (GPIO14) of Esp8266 NodeMCU
- (iv) Connect HX711 amplifier's clock pin to D6 (GPIO12) of Esp8266 NodeMCU
- (v) The clock is provided by the microcontroller as it a master device

The connection between HX711 module and Esp8266 is shown in Fig. 13.



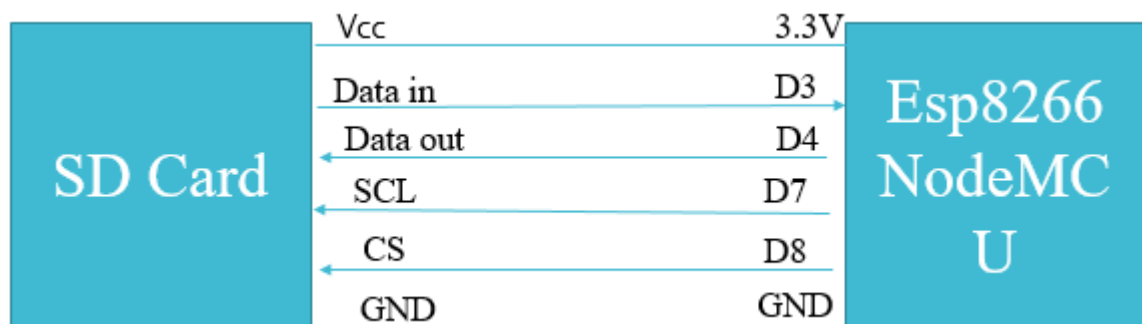
**Figure 13: Interfacing HX711 Module with Esp8266**

#### 4.2.4 Interfacing Secure Digital Card with Esp8266 NodeMCU over Serial Peripheral Interface

Over SPI interface, the communication between microcontroller (master) and SD card (slave) is done via 4 pins which are clock, chip select (CS), data in and data out. The connection is as follows:

- (i) Data in is connected to D3 (GPIO0) of Esp8266 NodeMCU
- (ii) Data out is connected to D4 (GPIO2) of Esp8266 NodeMCU
- (iii) Serial clock is connected to D7 (GPIO13) of Esp8266 NodeMCU
- (iv) CS is connected to D8 (GPIO15) of Esp8266 NodeMCU.

Figure 14 shows the connections between SD card and microcontroller used.



**Figure 14: Interfacing Secure Digital card board with Esp8266**

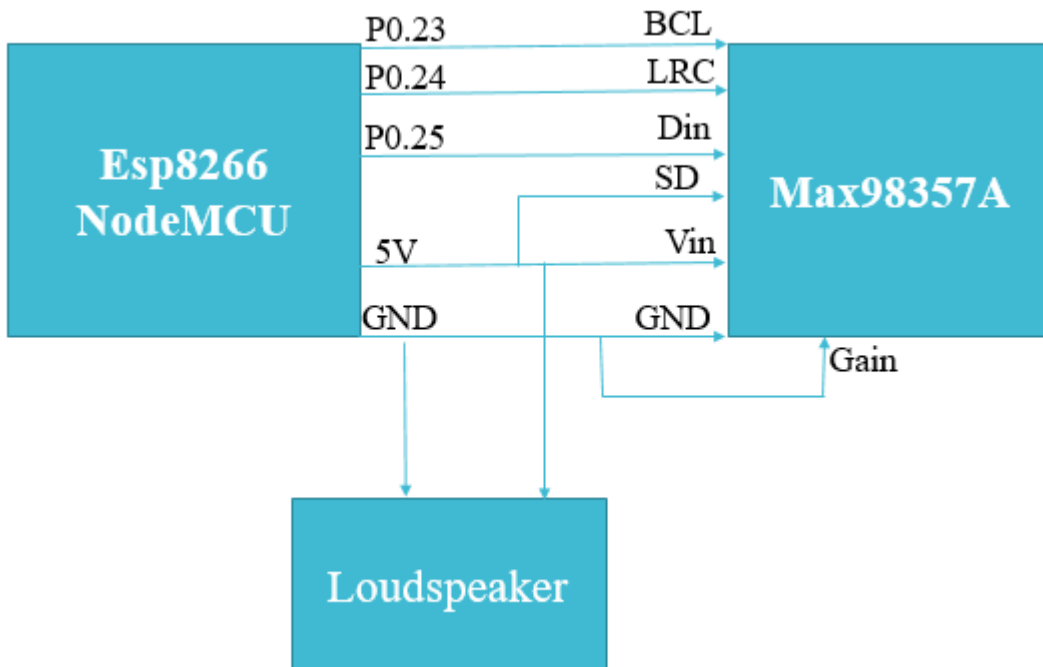
#### 4.2.5 Interfacing Esp8266 NodeMCU with Max98357A Inter-Integrated Circuit Sound Audio Amplifier over Inter-Integrated Circuit Sound Interface

These include the following:

- (i) Inter-Integrated Circuit Sound interface is the standard serial interface protocol for transferring audio data between devices.

- (ii) Audio data is stored on SD card as WAVE file and sent out over the I2S port of Esp8266 NodeMCU to Max98357A I2S audio amplifier and forwarded to the loudspeaker.
- (iii) Inter-Integrated Circuit Sound has 3 Wire connections which are: SCL, WS and SD. The connection is as follows:
  - (a) Serial clock (SCL) i.e. pin P0.23 of ESP8266 NODEMCU is connected to the Bit clock (BCL) of amplifier. This connection indicates which channel for incoming data to the amplifier.
  - (b) Word Select (WS) i.e. pin P0.24 of ESP8266 NODEMCU is connected to the LRC (Left/Right Clock) of amplifier. This connection tells the amplifier when to read data on the data pin.
  - (c) Serial Data (SD) i.e. pin P0.25 of ESP8266 NODEMCU is connected to the Din (Data In) of amplifier. This connection carried the actual data.
  - (d) Connect Vcc of microcontroller to Vin pin of amplifier.
  - (e) Connect GND of microcontroller to GND pin of amplifier.
  - (f) Gain pin on the amplifier can be connected to Vcc or GND of the microcontroller depending on the quantity of the gain we want. We connect it to ground to get 12dB of gain.
  - (g) The SD pin, this pin is used either as shutdown mode or to select the channel output depending on which pin of microcontroller it is connected to.
  - (h) For our case SD pin of amplifier is connected to 5V of the microcontroller to activate stereo average output.
  - (i) Here Esp8266 NodeMCU is acting as a master since it is generating bit clock, word-select signal and data.

Figure 15 shows the connections between audio amplifier and microcontroller used.



**Figure 15: Interfacing Max98357A module with Esp8266**

### 4.3 Results of the Device Design

The complete functional version of Swahili speaking Body Weight Scale was implemented as a speaking instrument. A prototype for Swahili speaking Body Weight Scale was physical designed and all hardware worked as intended. The main hardware components used are 4 pieces of 50 Kg Load cell, HX711 amplifier module, Esp8266 NodeMCU, oled1.3-inch display, Max98357A I2S audio amplifier and 32GB micro SDHC card. The weighing system was developed using Arduino programming language. This first version of the device implements the functionalities of the device which were captured in the requirements engineering stage.

Note that for this device to operate it needs to be plugged to the external power supply. The long Blue and Red cables are power cable connected to voltage regulator from the eternal power supply. Since the eternal power supply is providing 5V and esp8266 module uses 3.3V, a voltage regulator was used to convert 5V to 3.3V. This device can also operate by using internal battery of 3V or any battery from 1V can operate as the used voltage regulator is regulating the supplied voltage to the needed voltage (3.3V). Figure 16 shows the constructed working prototype of the system.



**Figure 16: Constructed working prototype**

#### **4.4 Data Acquisition and Preparation**

After having all the hardware connected together, the second step was to prepare audio data. Audio data was sampled and stored on an SD card with .WAV extension. Each weight number was stored separately as an individual wave file. For instance, .WAV file of kilo moja, .WAV file of Kilo mbili, .WAV file of Kilo tatu and so on. Audio data were successfully attained by recording weight numbers in Swahili language. The audio data consisted of 26 audio files which are: Karibu kwenye mzani, 1, 2, 3, 4, 5, 6, 7, 8, 9, 10, 20, 30, 40, 50, 60, 70, 80, 90, 100, 200, na, KIPIMO CHA UZANI NI KILO, Zingatiya afya yako Kwa Kupima Uzani Wako Kila mara and error message when weight is above 200 Kgs (This is because the maximum capacity of the developed scale is 200 Kgs as 4 pieces of 50 Kgs load cells were used in the design). All the 26 audio files were successfully stored on the SD card in the WAVE format. This was very important to have uniform data with the extension '.wav' for it has good quality and is suitable for audio loops.

After having audio data in place, the system which measures weight and displays scale readout on LCD screen was developed using Arduino. Finally, the mobile application was developed using android. This mobile application is used to access the weight scale outputs whereby you can listen to the weight announcement through the smartphone which is connected to the scale through Wi-Fi. The scale uses UDP socket to send data to the smartphone.

## 4.5 Device Operation

The operation of the Swahili Speaking Weight Scale is as follows:

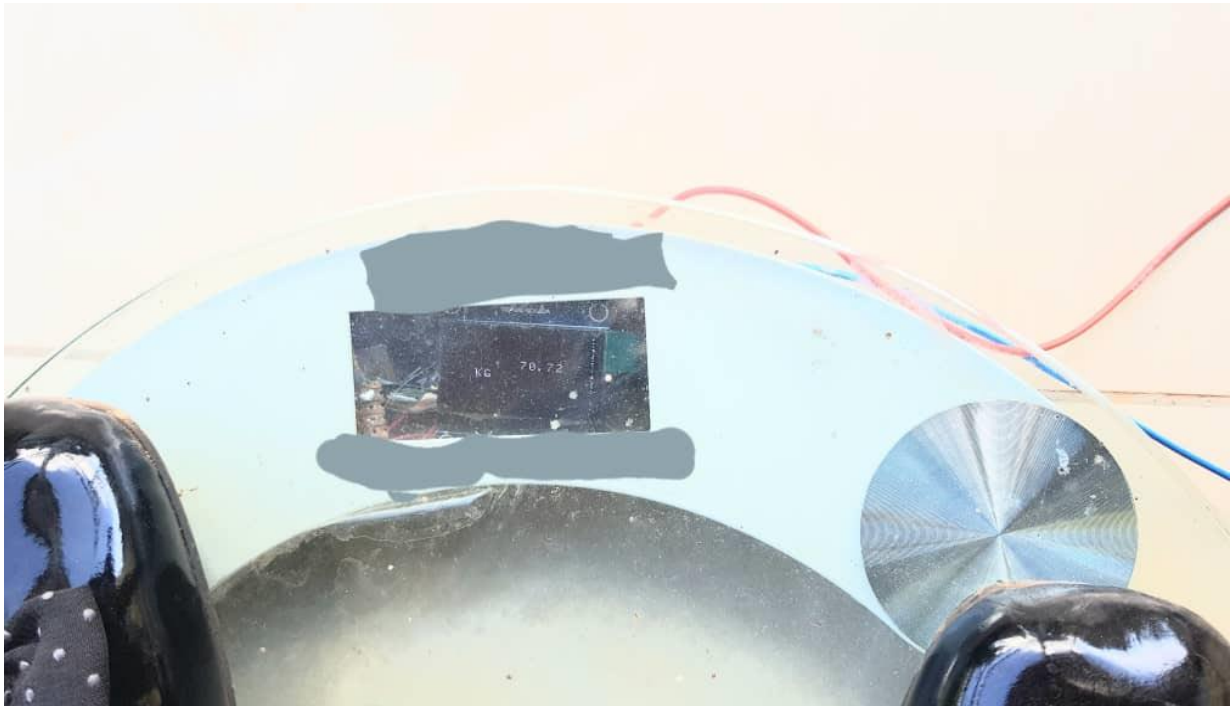
- (i) The user sets up a hotspot to create a wireless connection between their smartphone and the weight scale by using the network credentials which are configured with the Weight Scale as follows:
  - (a) Network name: Scale
  - (b) Password of the network: 12345678
- (ii) Upon submission of the network information, weight scale creates broadcast communication with the connected smartphones and the scale calibrates itself automatically. Once the scale is calibrated it then check whether the readout is 0 Kgs then after displays/announces welcome note “Karibu Kwenye mzani” to notify users that it is ready for measurements.
- (iii) The user can then step onto the scale’s platform to weigh himself/herself. When an object is placed on scale’s platform, load cells sense its weight and then send some data to the control unit for further processes. The microcontroller manipulates received data by doing some calculations and displays the output on the LCD screen and finally call the corresponding WAVE file from an SD card to announce the output verbally and finally broadcast weight measurement to the connected smartphones using UDP protocol.

Figure 17, 18 and 19 show the discussed results



**Figure 17: Picture showing a visually impaired person using the scale**

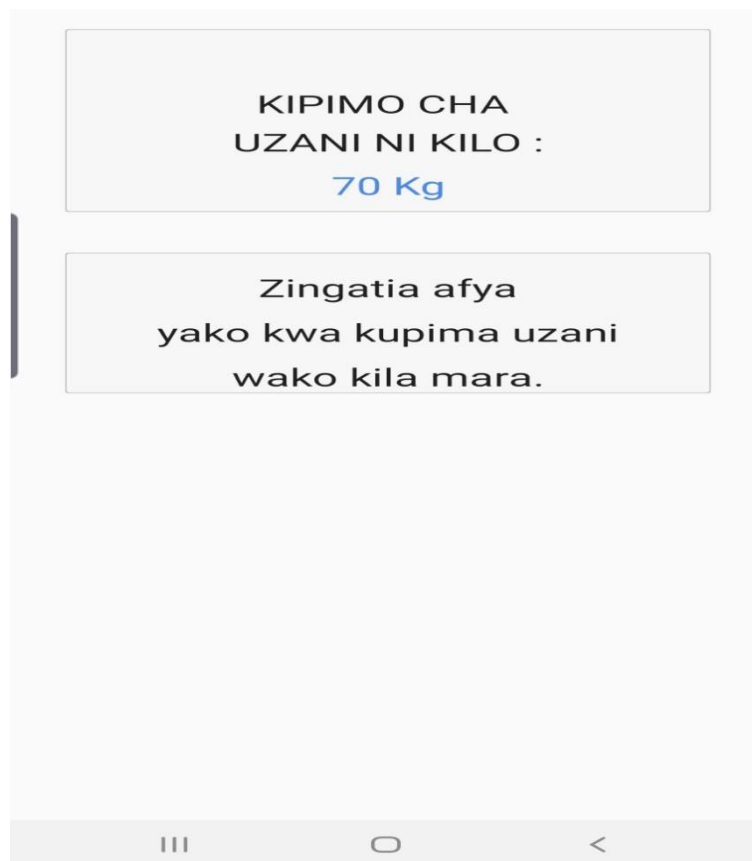




**Figure 18: Scale readout on the display**

The results also show that the announced weight is the same as data sent to the smartphone meaning that the scale does not send decimal place numbers to the mobile application.

Figure 19 shows the screenshot of data sent to the smartphone.



**Figure 19: Scale data sent to the smartphone**

## 4.6 Testing

After device design and implementation, testing was accomplished with each development cycle in four steps. Unit testing was conducted to ensure that each system module is working correctly. Next integration testing was carried out to expose faults in the interaction and connectivity between the modules. Performance testing was subsequently carried out to check the accuracy and determine the maximum load the scale can handle without performance degradation. Finally, usability testing was also done to see how easy the scale is to be used by blind people.

### 4.6.1 Unit Test

Unit testing: Here, each functional module of the system was tested in isolation, the main units that were tested in isolation include:

#### (i) Weight Measurement Unit

This unit consists of weight sensors and display modules. It was tested to ensure that it measures, computes and display accordingly the scale readout on LCD screen. Table 5 summarizes the tests performed under the weight measurement unit.

**Table 5: Weight measurement unit test**

<b>System requirements</b>	<b>Results</b>
The scale should be powered on when no load is placed on its platform and it should auto calibrate itself.	PASS
The weight sensors should capture physical parameter which is weight of an object being measured and convert it into electrical signal for further processes.	PASS
The control unit should compute electrical signal produces by weight sensors and display the digital output of measured weight on the LCD screen.	PASS

#### (ii) Announcing Scale Measurement in Swahili

The objective of this test was to ensure if the measured weight can be announced appropriately, as described in Table 6.

**Table 6: Weight announcement unit test**

<b>System requirements</b>	<b>Results</b>
Audio files should be stored SD card. Those audio files consist of voices of weight in Kilograms in Swahili language	PASS
Control unit should compute electrical signal produced by the weight sensor.	PASS
Control unit should then call a corresponding audio file from an SD card	PASS
Control unit should forward the audio data to the audio amplifier for amplification then to the loudspeaker	PASS
Weight should be announced verbally in a clear voice	PASS

### (iii) Sending Scale Measurement to the Smartphone

This test was intended to check if only authorized smartphone can successfully receive the scale measurements. A smartphone and the scale communicate using Wi-Fi connection by using username and password configured in a scale. The results are summarized in Table 7.

**Table 7: Communication between the scale and android phone unit test**

<b>System requirements</b>	<b>Results</b>
The user should set up a Wi-Fi hotspot	PASS
The scale should be able to connect to the smartphone within vicinity through Wi-Fi android tethering whose credentials are the same as the ones configured with the scale	PASS
Once the connection is successful, the scale should broadcast scale readout to the android application	PASS

### 4.6.2 Integration Testing

In integration testing, individual units were combined and tested as a group. The purpose of this test was to expose faults in the interaction and connectivity between the modules, to validate whether the intended functionalities of each module are still working accordingly after the combination. Audio data were integrated into the weighing system and finally the integration testing involved incorporation of the mobile application with the rest of the Speaking weight scale experience units and testing whether the entire system exhibits the appropriate behavior. This also involved ensuring the weight announcement on the speaking scale works efficiently with the rest of the hardware on the weight scale. For instance, to ensure that the announced weight is the same as the displayed weight on the screen as well as the data sent to the

smartphone. This test was successful since the announced weight is the same as the data sent to the smartphone.

### 4.6.3 Performance Testing

Here the scale was tested to determine the maximum weight it can measure without performance degradation. This test was also conducted to ensure the stability of the scale as well as the accuracy of the scale when it is measuring heavy loads. To perform this test, different objects (certified scale calibration weights) with known weight were put onto the scale platform to be measured and the measured weight were recorded. Each object was reweighed two times. Placed certified calibration weights on the scale and note the output. Took the measured object off the scale and let the scale return to zero. Placed the same object on the scale again. Noted the output again. The results then showed that the scale displayed the same weights on each object. The expected weight of given objects was then compared with the recorded ones to assess the performance of the scale. Table 8 shows the comparison of displayed weight and the expected weight of the used certified scale calibration weights.

**Table 8: Scale's performance test results**

<b>Object Name</b>	<b>Expected Weight (Kg)</b>	<b>Measured Weight (Kg)</b>	<b>Error (%)</b>
Certified scale calibration weights of 100 Kgs	100	99.50	0.50
Certified scale calibration weights of 110 Kgs	110	109.45	0.50
Certified scale calibration weights of 150 Kgs	150	149.24	0.51
Certified scale calibration weights of 175 Kgs	175	174.10	0.52

The results showed that the scale is able to measure the objects whose weight is under 200 Kgs within the accuracy of 1% error range of the actual weight.

### 4.6.4 Usability Testing

Here the device was tested to see how easy it is to be used by blind people. This was done by observing visually impaired people as they attempt to use the scale. Usability test has helped to identify difficulties that a blind person can face while using this scale and made improvement so that visually impaired people enjoy using Swahili speaking Body Weight Scale.

During usability testing majority of blind people revealed that speaking scale will help to raise awareness of controlling their body weight for healthy life. This is due to the fact that the scale speaks out the output which removes too much dependence. This is an important feature for

blind people who need assistance from sighted person in many aspects of their lives. Users (blind people) also revealed that they enjoy using a speaking scale though they still need assistance



from sighted person to plug the scale to the power and direct them to the scale's platform. Figure 20 shows a low vision person using Swahili speaking body weight scale.

**Figure 20: Picture taken during usability testing**

## CHAPTER FIVE

### CONCLUSION AND RECOMMENDATIONS

#### 5.1 Conclusion

This project aimed to raise people awareness of controlling their weight and hence live healthy life as well as to encourage the adaptation of development of technology in Swahili language by developing a Swahili speaking body weight machine. The project focused on Swahili speaking instrument due to its significance in providing access of measuring devices to Swahili speaking visually impaired people and due to the fact that visually impaired people receive little consideration especially in third world countries when new technology is introduced as many advanced technologies are limited to developed countries for instance no talking scale can announce weight in Swahili language.

This study evaluated the current body talking weight machines and found that one of the research gaps is ignorance in weight control for people living with visual impairment in Tanzania. After collecting and analyzing needs, perceptions and recommendations of visually impaired people on having Swahili speaking weight machine to offer Swahili speaking visually impaired people an efficient and seamless means of which to control their weight for their healthy life as self-weighing is recommended to all people, both functional and non-functional system requirements were established. From those requirements, the study came out with the Swahili Speaking Body Weight Scale.

#### 5.2 Recommendations

Based on our research and findings gathered, this study strongly encourages Tanzania League of Blind (TLB) the adoption of Swahili body speaking weight scales as they possess a great deal of potential to assist the blind community as a low vision health aid for health and weight track. This will not only help visually impaired persons; it is also an ideal solution for people who have mobility limitations as they can use a smartphone to listen to the scale measurements from some distance away from the device. The device will also help Swahili speaking community at large to adjust their lifestyle or diet habits to align with their body weight.

The scope of this project was to develop a speaking instrument which measures and announces weight in Swahili language to provide an efficient and seamless means of which Swahili speaking visually impaired persons can use to control their weight. More research is open to integrate iBeacon technology to allow blind people to navigate to the device's location safely.

This project also opens the door to other scholars to research on incorporating other features such as BIM and body fat percentage calculation then advices users accordingly whether to change lifestyle or diet to stick to healthy habits in long run. Moreover, the government should encourage to do regular self-weighing to avoid unnecessary body weight control hence live healthy life.



## REFERENCES

- Ababei, C. (2013). *SPI and SD cards, EE-379 Embedded Systems and Applications*. Electrical Engineering Department, University at Buffalo. <https://www.google.com>
- Adela, H. & Frank, B. (2015). The Epidemiology of Obesity: A Big Picture. *Pharmacoeconomics*, 33(7), 673-689.
- Andrea, L. R., Jennifer, A. T., Loni, P. T., & Yvonne, L. M. (2013). Mobility, disability, and social engagement in older adults. *Journal of Aging and Health*, 24(4), 617-637.
- Avia Semiconductor. (2018). *HX711–24 Bit Analog to Digital Converter (ADC)*. <https://components101.com/ics/hx711-24-bit-analog-digital-converter-adc>
- CCBRT. (2017). *Eye*. <http://www.ccbt.or.tz/programmes/disability/eye/>
- Dori, M. S., Gary, G. B., Sandy, A., & Deborah, F. T. (2015). Weighing everyday matters: Daily weighing improves weight loss and adoption of weight control behaviors. *Journal of the Academy of Nutrition and Dietetics*, 115(4), 511-518.
- Dori, M. S., Deborah, F. T., Gary, G. B., Susan, E., Carmen, S. H., & Dianne, S. W. (2013). The efficacy of a daily self-weighing weight loss intervention using smart scales and email. *Obesity*, 21(9), 1789-1797.
- East African Community Secretariat. (2017). *756-eac-partner-states-directed-to-formulate-national-kiswahili-language-policies*. Retrieved from East African Community. <https://www.eac.int/press-releases/138-education,-science-technology-news/756-eac-partner-states-directed-to-formulate-national-kiswahili-language-policies>
- Eltagi, A. M., Abdalla, H., & Abdalla, I. (2015). Prevalence and possible risk factors associated with overweight and obesity among adults in mayo area in Khartoum state-Sudan. *World Journal of Pharmacy and Pharmaceutical Sciences*, 6(5), 174-185.
- Embedded Artists. (2018). *LPC4088 Developer's Kit - User's Guide*. <http://www.google.com>
- Engiexpo. (2019). *Weighing scale expo*. <https://engiexpo.com/weighing-scale-exhibition-why-it-is-important-for-your-business/>
- Espressif Systems. (2015). *ESP8266EX Datasheet*. <http://www.google.com>

- Everyday Sight. (2020). *Talking weight scales*. <https://www.everydaysight.com/talking-weight-scales/>
- Fruh, S. M. (2017). Obesity: Risk factors, complications, and strategies for sustainable long-term weight management. *Journal of the American Association of Nurse Practitioners*, 29(1), 3-14.
- Gilad, T., Gal, Y., Hagai, L., Adi, L., Nehama, G., Estela, D., Dana, B. A., Shor, D. T., Arnon, A., Ari, S., Ziona, H., & Jeremy, D. K. (2016). Body-Mass Index in 2.3 Million Adolescents and Cardiovascular Death in Adulthood. *The New England Journal of Medicine*, 374(25), 2430-2440.
- Gilles, A. (2011). *When to use .WAV files: When to use MP3 files?* <https://www.premiumbeat.com/blog/when-to-use-wav-files-when-to-use-mp3-files-what-is-the-difference-between-the-two-formats/>
- Headphonesty. (2020). *Best Audio File Formats: What they are and Why they Matter*. <https://www.headphonesty.com/2020/04/best-audio-file-formats-explained/>
- Joel, L. (2019). *The 10 Most Common Audio Formats*. <https://www.makeuseof.com/tag/audio-file-format-right-needs/>
- Kamlesh, H. T., Vipul, M. P., & Bipin, D. P. L. (2013). Performance Evaluation of Strain Gauge Based. *International Journal of Latest Trends in Engineering and Technology (IJLTET)*, 2(1), 103-107.
- Katherine, M. F., Margaret, D. C., Brian, K. K., & Cynthia, L. O. (2012). Prevalence of Obesity and Trends in the Distribution of Body Mass Index among US Adults, 1999-2010. *The Journal of American Medical Association*, 307(5), 491-497.
- Kunal, D. G., & Dahikar, P. B. (2013). Design and Development of Novel Weighing Scale System. *International Journal of Engineering Research & Technology*, 2(5), 1668-1671.
- Load Cell Central. (2020). *Strain Gauge Load Cell Basics*. <https://www.800loadcel.com/load-cell-and-strain-gauge-basics.html>
- Magdalena, W., Urzędowicz, B., Motylewski, S., Zeman, K., & Pawlicki, L. (2016). Body mass index and waist-to-height ratio among schoolchildren with visual impairment. *Medicine*, 95(32), 1-7.

- Mahmoud, A., Carel, W. L., & Neil, G. D. (2017). Morbidity and mortality associated with obesity. *Annals of Translational Medicine*, 5(7), 1-12.
- Meredith, Y., Kim, S., Jennifer, M. B., Virginia, Q., & Carol, B. B. (2013). Accuracy and consistency of weights provided by home bathroom scales. *Public Health*, 13(11940), 1-5.
- Michelle, E. K., & Lara, V. (2020). Thematic analysis of qualitative data: AMEE Guide No. 131. *Medical Teacher*, 42(8), 846-854.
- NXP Semiconductors. (2017). *LPC408x/7x product data sheet*. <https://www.google.com>
- Palinkas, L. A., Horwitz, S. M., Green, C. A., Wisdom, J. P., Duan, N., & Hoagwood, K. (2015). Purposeful sampling for qualitative data collection and analysis in mixed method implementation research. *Administration and Policy in Mental Health and Mental Health Services Research*, 42(5), 533-544. doi:10.1007/s10488-013-0528-y
- Politzer, T. (2017). *March is Brain Injury Awareness Month*. <https://grantvisioncare.com/march-is-brain-injury-awareness-month>
- Rehab-Mart. (2020). *Five Language Digital Talking Bathroom Scale*. [https:// www. rehabmart. com/product/five-language-digital-talking-bathroom-scale-47027.html](https://www.rehabmart.com/product/five-language-digital-talking-bathroom-scale-47027.html)
- Reha-bmart. (2020). *Medical Scales*. Retrieved from [rehabmart](https://www.rehabmart.com/scales.html). <https:// www. rehabmart. com/scales. html>
- Rehab-Mart. (2021). *Talking scales*. [https:// www. rehabmart. com/ category/ talking\\_ scales. htm# bottom](https://www.rehabmart.com/category/talking_scales.htm#bottom)
- Roberta, B., & Hilary, M. (2016). Weighting for Health: Management, Measurement and Self-surveillance in the Modern Household. *Society for the Social History of Medicine*, 29(4), 757–780. doi: 10.1093/shm/hkw015
- Ruijun, C., Purav, S. M., Aakriti, G., Behnood, B., Rachel, D., Serene, I. C., Sudhakar, N., & Isuru, R. (2013). Most Important Outcomes Research Papers on Body Weight, Obesity and Cardiovascular Outcomes. *Cardiovascular Quality and Outcomes*, 6(6), 48–56.
- Saeed, M. O., Zainab, T., Ahmed, A. H., Osama, A., & Ishag, A. (2020). Prevalence and factors associated with overweight and central obesity among adults in the Eastern Sudan. *Plos One*, 15(4), 1-10.

Shirin, D., Mostafa, Q., Niloofar, P., & Roya, K. (2015). Health Impacts of Obesity. *Pakistan Journal of Medical Sciences*, 31(1), 239-242.

Silicon Laboratories. (2013). *FAT on SD Card*. <https://www.google.com>

Von-Wormer, J. J., French, S. A., Pereira, M. A., & Welsh, E. M. (2008). The Impact of Regular Self-weighing on Weight Management: A Systematic Literature Review. *The International Journal of Behavioral Nutrition and Physical Activity*, 5(54), 1-10.

Yaguang, Z., Mary, L. K., Susan, M. S., Cynthia, A. D., Linda, J. E., & Lora, E. B. (2015). Self-weighing in weight management: A systematic literature review. *Obesity*, 23(2), 256-65.

## APPENDICES

### Appendix 1: Guided Interview Questionnaire for Visually Impaired People

#### Introduction

My name is **Gloriose Nzasangamariya**, a master's student at the **Nelson Mandela African of Science and Technology (NM-AIST)**, Arusha. The aim of this questionnaire is to study the needy and the requirements for the development of Swahili speaking body Weighing Scale that will facilitate Swahili speaking visually impaired people to weigh themselves when monitoring their progress and health in an efficient and seamless manner. The information collected in this questionnaire will not be expose your identity by any means, therefore feel free to give your opinions.

#### Part One: General information

Please, choose one appropriate answers from the options provided below

1. What is your age bracket?
  - a. 16 - 30
  - b. 30 - 50
  - c. More than 50
2. What is your highest level of educational?
  - a. No formal education
  - b. Primary level
  - c. Ordinary level
  - d. Advanced level
  - e. University level
  - f. Others please specify
3. For how long have you been living with visual impairments?
  - a. Less than six months
  - b. six months to one year
  - c. one year to five years
  - d. More than five years

#### Part Two: Information related to body weight checkup and access to weighing machines

1. Do you normally weigh yourself for your body weight track?
  - a. Yes
  - b. No

2. If your answer on question1 was yes, which method do you frequently use?
  - a. Digital Bathroom scale
  - b. Talking Bathroom scale
  - c. Sighted persons assist me
  - d. When am sick I go to the hospital
  - e. Other (please specify)
3. If your answer on question1 was No, what is your biggest challenge, frustration, or problem preventing you from checking your weight?
  - a. I don't know how to interpret the scale readings
  - b. No convenient weight scale for visually impaired person in Tanzania
  - c. I don't trust the results that I am told.
  - d. I don't want to be too much dependent because I need a sighted person to read for me the scale readout.
4. Will speaking weight scale meet your needs?
  - a. Yes
  - b. Somewhat
  - c. I am not sure
5. In which language would you want announcements in a speaking weight scale to be made in?
  - a. English
  - b. Swahili

## **Appendix 2: Focus Group Discussion Questionnaire**

### **Introduction**

My name is **Gloriose Nzasangamariya**, a master's student at the **Nelson Mandela African of Science and Technology (NM-AIST)**, Arusha. The aim of this questionnaire is to study the need and the requirements for the development of Swahili speaking body Weighing Scale that will facilitate Swahili speaking visually impaired people to weigh themselves when monitoring their progress and health in an efficient and seamless manner. The information collected in this questionnaire will not be expose your identity by any means, therefore feel free to give your opinions.

1. How do visually impaired people track their body weight?
2. How do visually impaired people use weighing machines? who assist them when using it?
3. Are visually impaired people in Tanzania interested in monitoring their body weight?
4. What would you recommend to be done to increase the awareness of body weight control in visually impaired people?
5. In your opinion, would the Swahili speaking weighing machine to increase the awareness of body weight control in visually impaired people?
6. Please provide suggestions on some features we can add that would make speaking weighing machine indispensable for you?
7. What other devices would you like to see us offer to visually impaired people?

### **Appendix 3: Android Codes for a Smartphone to Communicate with a Scale in order to Send Scale Readout to the Smartphone for Remote Access**

```
package parametric.scale;
import android.content.Context;
import android.os.AsyncTask;
import android.speech.tts.TextToSpeech;
import android.support.v7.app.AppCompatActivity;
import android.os.Bundle;
import android.view.View;
import android.view.Window;
import android.view.WindowManager;
import android.widget.Button;
import android.widget.EditText;
import android.widget.TextView;
import android.widget.Toast;
import java.net.DatagramPacket;
import java.net.DatagramSocket;
import java.net.InetAddress;
import java.util.Locale;
public class Main extends AppCompatActivity implements View.OnClickListener{
    byte[] data = new byte[] {(byte)0,(byte)0,(byte)0}; // clt 0 g 1 kg, data data, msg
    byte[] msg = new byte[] {(byte)0,(byte)0}; // data to send to the scale 1 calibration
    boolean send= false;
    Button calib;
    TextView kg;
    EditText mass;
    TextToSpeech tts;
    @Override
    protected void onCreate(Bundle savedInstanceState) {
        super.onCreate(savedInstanceState);
        setContentView(R.layout.main);
```



```

getWindow().addFlags(WindowManager.LayoutParams.FLAG_KEEP_SCREEN_ON);//Always
on
    Window window=getWindow();
    window.setFlags(256,256);
    window.setFlags(1024,1024);
    calib=(Button)findViewById(R.id.calib);
    calib.setOnClickListener(this);
    mass=(EditText) findViewById(R.id.weight);
    kg=(TextView) findViewById(R.id.kg);
    tts=new TextToSpeech(getApplicationContext(),new TextToSpeech.OnInitListener(){
        @Override
        public void onInit(int i){
            if(i==TextToSpeech.SUCCESS){int lang=tts.setLanguage(Locale.ENGLISH);}
            });
        Scaletask();

    }

    public void onBackPressed(){

    public void Speak(String a){tts.speak(a,TextToSpeech.QUEUE_FLUSH,null);}//function for
test to speak

    public void updateStatus(final String mas,final byte d){
        runOnUiThread(new Runnable() {
            @Override
            public void run() {
                kg.setText(mas);
                if(d==1){
                    Toast.makeText(getApplicationContext(),"Calibration is successful",
Toast.LENGTH_LONG).show();}
                });
            }

        public void onClick(View v){
            if(!(Integer.parseInt(mass.getText().toString())<50)){

```

```

switch (v.getId()) {
    case R.id.calib :
        Toast.makeText(getBaseContext(), "Calibration is calibrated",
Toast.LENGTH_LONG).show();
        Speak("The Scale is calibrated; Successfully!");
        break;
    }
    }else{Toast.makeText(getBaseContext(),"Enter Value greater than 50g !",
Toast.LENGTH_LONG).show();
    }

} // handle on click listener
private void Scaletask(){
    Server c=new Server();c.executeOnExecutor(AsyncTask.THREAD_POOL_EXECUTOR);
    Client s=new Client();s.executeOnExecutor(AsyncTask.THREAD_POOL_EXECUTOR);
}
private class Client extends AsyncTask<Void, Void, Void>
{
    @Override
    protected void onPreExecute() { }
    @Override
    protected Void doInBackground(Void... params)
    {
        DatagramSocket ds=null;
        try{msg[0]=(byte)1;
            for(;;){
                ds=new DatagramSocket();
                InetAddress server=InetAddress.getByIp("192.168.43.255");//broad casting to
connected devices// used for calibration
                msg[1]=(byte)0;msg[2]=(byte)2;
                byte[] sendData = new String(msg).getBytes();
                DatagramPacket dp=new DatagramPacket(sendData, sendData.length, server,
23654);

```

```

        ds.send(dp);
        ds.close();
        Thread.sleep(100);
    }}catch(Exception e){}
    return null;}

@Override

protected void onPostExecute(Void result) { }
}

private class Server extends AsyncTask<Void, Void, Void>
{
    @Override
    protected void onPreExecute() { }

    @Override
    protected Void doInBackground(Void... params)
    {
        try{while(true){
            DatagramSocket server=new DatagramSocket(23652);
            byte[] dut=new byte[1024];
            DatagramPacket rcp=new DatagramPacket(dut, dut.length);
            server.receive(rcp);
            byte[] wv=rcp.getData();
            if(wv[0]==1){
                wv[0]=0;
                updateStatus(wv[1]+" Kg",wv[2]);
                if(wv[1]>0){Speak(wv[1]+" kg");}
            //receiving data from the scale
            }
            server.close();
            Thread.sleep(1500);
        }
    }catch(Exception e){
        //updateStatus("ERROR in Transimission");
    }
}

```

```

    }
    return null;
}
@Override
protected void onPostExecute(Void result) { }
}
}

```

### **Congratulations for scale Codes**

```

#include <Arduino.h>
#include <ESP8266WiFi.h>
#include <WiFiUDP.h>
#include <HX711_ADC.h>
#include <EEPROM.h>
#include <Wire.h>
#include "OLED.h"
#define ST_LED 2
OLED display(D2,D1);
unsigned int localPort = 6000;//local port to listen on
unsigned int remotePort = 23900;//local port to talk to
char packetBuffer [10];
char replyBuffer[]={0x07,0x01,0x00};// cmd selector, data1 data2
char ssid[]="scale";
char pass[]="12345678";
const int HX711_dout= D5;
const int HX711_sck= D6;
HX711_ADC LoadCell(HX711_dout, HX711_sck);
const int eepromAdress=0;
float calibration;
boolean bcl=false;
unsigned long t =0;
char weight[7];
IPAddress remoteIp;

```

```

WiFiUDP Udp;

void setup(){
  Serial.begin(9600);
  LoadCell.begin();
  LoadCell.start(2000,false);
  if(LoadCell.getTareTimeoutFlag()||LoadCell.getSignalTimeoutFlag()){
  LoadCell.setCalFactor(19.13);}
  while(!LoadCell.update());
  LoadCell.tareNoDelay();
  LoadCell.setCalFactor(19.13);
  LoadCell.tareNoDelay();
  }
void loop(){
  if(LoadCell.update()&&bc1){
    float m;int i=0;
    for(;i<10;i++){
  float w =LoadCell.getData();
  m+=w; i++;
  delay(10);

  }
  m/=10;
  //dtostrf(m)
  Serial.println(m);
  m=0.0;
  }
  if (LoadCell.getTareStatus() == true) {
  bcl=true;
  }
}
}

```

## RESEARCH OUTPUTS

### (i) **Publication**

Gloriose, N., Ramadhani, S., & Shubi, F. K. (2021). Development of Self Speaking Body Weight Scale for Visually Impaired People in Tanzania. *International Journal of Advances in Scientific Research and Engineering*, 7(7), 1-9.

### (ii) **Poster Presentation**