

2021-06

Strategies to improve anaerobic digestion and environ-economic analysis of municipal solid wastes management options

Richard, Edwin

NM-AIST

<https://doi.org/10.58694/20.500.12479/1311>

Provided with love from The Nelson Mandela African Institution of Science and Technology

**STRATEGIES TO IMPROVE ANAEROBIC DIGESTION AND ENVIRON-ECONOMIC
ANALYSIS OF MUNICIPAL SOLID WASTES MANAGEMENT OPTIONS**

Edwin Ndibalema Richard

**A Thesis Submitted in Fulfilment of the Requirements for the Degree of Doctor of
Philosophy in Environmental Sciences and Engineering of the Nelson Mandela African
Institution of Science and Technology**

Arusha, Tanzania

June, 2021

ABSTRACT

Different strategies have widely been applied for improving the anaerobic digestion of the organic fraction of municipal solid wastes. However, because of the heterogeneous compositions of organic fraction of municipal solid wastes, studies on different strategies are still required. This thesis focused on examining methods to improve anaerobic digestion of organic fraction of municipal solid wastes and environ-economic analysis of municipal solid wastes management options. Firstly, the study examined the effects of fungal (*Pleurotus ostreatus*) treatment of the banana leaves wastes towards edible mushrooms and biogas recovery. Secondly, the study assessed the effectiveness of banana winery wastewater in digesting the banana leaves wastes to improve methane yield. Thirdly, the study examined the potential of edible clay soils towards improving the anaerobic digestion of food wastes for biogas recovery. Next, the study analyzed and compared the environmental impacts of anaerobic digestion and other municipal solid waste management scenarios in the Arusha City of Tanzania. Finally, the study assessed the economic feasibility of the biogas plants for treating food and banana leaves wastes in the Arusha City of Tanzania. All the anaerobic digestion experiments were carried out in batch reactors. The environmental impact was analyzed using a life cycle analysis methodology. Fungal treatment of banana leaves wastes prior to anaerobic digestion process resulted in the biogas yield of 282 mL g⁻¹ VS⁻¹ and production of 181 ± 19 g of edible mushrooms per 2 kg of banana leaves wastes. The cost analysis revealed that mushroom cultivation has a higher economic value and therefore favoured before the anaerobic digestion process. Banana winery wastewater pre-treatment of banana leaves waste resulted in increased methane yield by 193% compared to non-pretreated banana leaves waste. The edible clay soils supplementation in the anaerobic digestion process resulted in an increase of 26.9% methane yield in a reactor with edible clay soils supplementation. Evaluations on environmental impacts revealed that the anaerobic digestion process outranked the current management option (Landfill) with the least environmental burdens. The study also revealed it is economically viable to invests the biogas plants for treating food and banana leaves wastes in Arusha City of Tanzania.

DECLARATION

I, Edwin Ndibalema Richard do hereby declare to the Senate of the Nelson Mandela African Institution of Science and Technology that this thesis is my own original work and that it has neither been submitted nor being concurrently submitted for degree award in any other institution.

Edwin Ndibalema Richard

Name and Signature of the Candidate

Date

The above declaration is confirmed

Prof. Karoli N. Njau

Name and Signature of Supervisor 1

Date

Prof. Revocatus L. Machunda

Name and Signature of Supervisor 2

Date

Prof. Askwar Hilonga

Name and Signature of Supervisor 3

Date

COPYRIGHT

This thesis is copyright material protected under the Berne Convention, the Copyright Act of 1999 and other international and national enactments, in that behalf, on intellectual property. It must not be reproduced by any means, in full or in part, except for short extracts in fair dealing; for researcher private study, critical scholarly review or discourse with an acknowledgement, without written permission of the Deputy Vice-Chancellor for Academic, Research and Innovation, on behalf of both the author and the Nelson Mandela African Institution of Science and Technology.

CERTIFICATION

The undersigned certify that they have read the thesis titled “Strategies to Improve Anaerobic Digestion and Environ-economic Analysis of Municipal Solid Wastes Management Options” and approve for submission to the Nelson Mandela African Institutions of Science and Technology Senate for the award considerations of the PhD degree in Environmental Science and Engineering.

Prof. Karoli N. Njau

Name and signature of supervisor 1

Date

Prof. Revocatus L. Machunda

Name and signature of supervisor 2

Date

Prof. Askwar Hilonga

Name and signature of supervisor 3

Date

ACKNOWLEDGEMENTS

All the glory to almighty God for his daily healing, peace, guidance and strength to accomplish my PhD study. Thank you, the almighty God.

I want to thank the Nelson Mandela African Institution of Science and Technology (NM-AIST) and the African Development Bank for financial support during my stay at NM-AIST. I extend my appreciation to my employer, the University of Dar es Salaam for a study leave to pursue this thesis. My sincere gratitude goes to my supervisors, Prof. Karoli N. Njau, Prof. Revocatus L. Machunda and Prof. Askwar Hilonga from the school of Materials, Energy, Water and Environmental Sciences, for their supervision and guidance to accomplish this thesis.

I would also like to extend my gratitude to my fellow students and NM-AIST lab technicians for their cooperation and support during the study period. My appreciation also goes to Eng. Marco Chacha and Eng. James Lobikoki of the environment and sanitation department of the Arusha City Council for their contributions in providing necessary data for this study. I am also grateful to Pentecostal Evangelistic Fellowship of Africa and Nambala Worship Centre for their co-operations, spiritual teachings, and prayers, which were vital to my life while studying at NM-AIST.

My unique, sincere appreciations to my wife; Consolatha Shayo, for her patience, encouragement and taking care of our daughter (Abigail) during my absence. My appreciations also go to my mother; Mrs Specioza Kamala, my brothers; Audiphax, Godwin, Godwil, and my sister; Justa Kamala for their care, love, and support during my PhD study.

DEDICATION

This work is dedicated to the Almighty God for his protection for me, my family and all Tanzanians, especially during the difficult times of the COVID 19 pandemic disease outbreak.

TABLE OF CONTENTS

ABSTRACT.....	i
DECLARATION.....	ii
COPYRIGHT.....	iii
CERTIFICATION.....	iv
ACKNOWLEDGEMENTS.....	v
DEDICATION.....	vi
TABLE OF CONTENTS.....	vii
LIST OF TABLES.....	xi
LIST OF FIGURES.....	xiii
LIST OF PLATES.....	xiv
LIST OF ABBREVIATIONS AND SYMBOLS.....	xv
CHAPTER ONE.....	1
INTRODUCTION.....	1
1.1 Background of the Problem.....	1
1.2 Statement of the Problem.....	3
1.3 Rationale of the Study.....	4
1.4 Research Objectives.....	5
1.4.1 General Objective.....	5
1.4.2 Specific Objectives.....	5
1.5 Research Questions.....	5
1.6 Significance of the Study.....	6
1.7 Delineation of the Study.....	7
CHAPTER TWO.....	8
LITERATURE REVIEW.....	8
2.1 Municipal Solid Wastes Generations and Compositions.....	8
2.2 The Anaerobic Digestion Processes.....	8
2.2.1 Hydrolysis.....	8
2.2.2 Acidogenesis.....	9
2.2.3 Acetogenesis.....	9

2.2.4	Methanogenesis	10
2.3	Strategies to Optimize the Anaerobic Digestion Process of Municipal Solid Wastes	10
2.3.1	Hydrolysis Stage Optimization.....	10
2.3.2	Acidogenesis and Acetogenesis Stages Optimization	13
2.3.3	Methanogenesis Stage Optimization	15
2.4	Resources Recovery from the Anaerobic Digestion of Municipal Solid Wastes.....	17
2.4.1	Utilization of Biogas as an Energy Source	17
2.4.2	Utilization of Digestate as Fertilizer or Soil Amendment	17
2.5	Environmental and Economic Benefits of Anaerobic Digestion of Municipal Solid Wastes	18
2.6	Experiences with the Realization of Biogas Plants from other Countries	19
2.7	Life cycle Analysis and its Utilization to Evaluate Environmental Impacts	21
2.8	Key Findings and Knowledge Gaps	22
2.8.1	Key Findings.....	22
2.8.2	Knowledge Gaps.....	22
CHAPTER THREE.....		24
MATERIALS AND METHODS.....		24
3.1	Examinations of the Effects of Fungal (<i>Pleurotus ostreatus</i>) Treatment of the Banana Leaves Wastes Towards Edible Mushrooms and Biogas Recovery.....	24
3.1.1	Materials	24
3.1.2	Characterization of the Banana Leaves Wastes for the Fungal Treatment	24
3.1.3	Fungal (<i>Pleurotus ostreatus</i>) Treatment of Banana Leaves Wastes	28
3.1.4	Anaerobic Digestion of Fungal Treated and Un-treated Banana Leaves Wastes	31
3.2	Assessing the Effectiveness of Banana Winery Wastewater in Digesting the Banana Leaves wastes to Improve Methane Yield	32
3.2.1	Banana Leaves and Bottle Washing Water Samples.....	32
3.2.2	Feedstock Characterization.....	33
3.2.3	Pre-treatment of Banana Leaves	33
3.2.4	Anaerobic Digestion Process	34
3.3	Examination of the Potential of Edible clay Soils towards Improving Anaerobic	

	Digestion of Food Wastes for Biogas Recovery	34
3.3.1	Food Wastes and Edible Clay Soils Samples.....	34
3.3.2	Food Wastes and Edible Clay Soils Characterization.....	35
3.3.3	Batch Experiments.....	35
3.4	Analysis of the Environmental Impacts of Anaerobic Digestion and other Municipal Solid Waste Management Scenarios in the Arusha City of Tanzania	36
3.4.1	Municipal Solid Waste Management in a Study Area	36
3.4.2	The Life Cycle Assessment Methodology	39
3.5	To assess Economic Feasibility of the Biogas Plant for Municipal Solid Waste Management in Arusha City of Tanzania.....	48
3.5.1	Estimation of the Investment Costs	48
3.5.2	Estimations of Operation and Maintenance Costs.....	49
3.5.3	Estimations of the Revenues.....	49
3.5.4	Economic Analysis of the Biogas Plants	49
	CHAPTER FOUR.....	51
	RESULTS AND DISCUSSION.....	51
4.1	Effects of Fungal (<i>Pleurotus ostreatus</i>) treatment on Banana Leaves Wastes towards Edible Mushrooms and Biogas Recovery.....	51
4.1.1	Characterization of the Banana Leaves Wastes	51
4.1.2	Fungal Treatment (<i>Pleurotus ostreatus</i>) of Banana Leaves Wastes	52
4.1.3	Anaerobic Digestion Process of Fungal Treated Banana Leaves Wastes	55
4.1.4	Cost Analysis of Fungal (<i>Pleurotus ostreatus</i>) Treatment of Banana Leaves Wastes	58
4.2	Effectiveness of Banana Winery Wastewater in Digesting the Banana Leaves Wastes to Improve Methane Yield	61
4.2.1	Feedstock Characteristics	61
4.2.2	Effect of the Pre-treatment on Lignocellulosic Components.....	64
4.2.3	Effect of the Pre-treatment on Biogas Productions	66
4.3	The Potential of Edible Clay Soils towards Improving Anaerobic Digestion of Food Wastes for Biogas Recovery	71
4.3.1	Substrates Characteristics for the Anaerobic Digestion Process	71

4.3.2	Trace Elements in Edible Clay Soils	71
4.3.3	Effect of Edible Clay Soil Supplementation on Methane Yield	73
4.3.4	Effect of Edible Clay Soil Supplementation on Methane Contents.....	76
4.4	Analysis of the Environmental Impacts of Anaerobic Digestion and other Municipal Solid Waste Management Scenarios in the Arusha City of Tanzania	77
4.4.1	Environmental Impacts of Systems without Resources Recovery	77
4.4.2	Impacts of the Resource Recovery	82
4.4.3	Sensitivity Analysis	85
4.5	Economic Analysis of Biogas Power Plant in Arusha City	91
	CHAPTER FIVE.....	97
	CONCLUSION AND RECOMMENDATIONS	97
5.1	Conclusion	97
5.2	Recommendations.....	98
	REFERENCES.....	99
	RESEARCH OUTPUTS.....	122

LIST OF TABLES

Table 1:	Summary of advantages and disadvantages of pre-treatment strategies to optimize the hydrolysis stage	12
Table 2:	Summary of results of anaerobic digestion improvement upon trace elements and granular activated carbon supplementation.....	14
Table 3:	Various materials with different carbon-nitrogen ratios.....	16
Table 4:	Purchasing and selling price of the recyclable materials at pre-processing centres...	38
Table 5:	Municipal solid wastes collection in Arusha wards	39
Table 6:	Description of the considered scenarios for the life cycle assessment.....	42
Table 7:	Inventory data under each scenario per ton of municipal solid wastes	43
Table 8:	Moisture and major elemental composition (%) of the typical wastes in a study area	45
Table 9:	Characteristics of banana leaves before and after fungal treatment (Mean \pm SD).....	52
Table 10:	Mushroom formation, number of clusters, fruit bodies, yield and biological efficiency	54
Table 11:	Trace elements compositions in banana leaves before and after fungal treatment	55
Table 12:	Cost analysis of the fungal -treatment on banana leaves	60
Table 13:	Banana wine bottle-washing water characteristics.....	63
Table 14:	Metal elements in banana leaves (Mean \pm standard deviations of three replicates) ..	64
Table 15:	Characteristics of substrates used in the anaerobic digestion process	64
Table 16:	biomass compositions changes of banana leaves before and after pre-treatment.....	65
Table 17:	Characteristics of substrates used in the anaerobic digestion process	71
Table 18:	Macronutrients, trace and heavy metal elements in edible clay soils (Mean \pm standard deviations of three replicates)	72
Table 19:	Environmental impacts from the production of hydropower electricity	83
Table 20:	Environmental impacts from the production of mineral fertilizers options.....	84
Table 21:	Environmental impact categories result with resources recovery	85
Table 22:	Sensitivity analysis on 5% improvement of process and resources recoveries.....	88
Table 23:	Compared ReCiPe 2008 Midpoint (H). V1.13 results with other life cycle impact assessment methods without resources recovery	89

Table 24: Investment costs for the biogas power plant treating food and banana leaves waste in Arusha City	92
Table 25: Operation and maintenance costs for the biogas plant in Arusha City.....	94
Table 26: Annual revenue for the biogas power plant treating food and banana leaves waste in Arusha City	96
Table 27: Economic analysis of the biogas power plant	96

LIST OF FIGURES

Figure 1:	Organic fraction market wastes compositions at Samunge market	27
Figure 2:	Experimental layout for biogas lab digester	32
Figure 3:	Schematic layout for the biogas biodigester	36
Figure 4:	The system boundary of the study	41
Figure 5:	Daily biogas yields of un-treated and fungal treated banana leaves by <i>P. ostreatus</i> ; data are means of the two replicates	57
Figure 6:	Cumulative biogas yields of un-treated and fungal treated banana leaves by <i>P. ostreatus</i> ; data are means of the two replicates.....	58
Figure 7:	pH values of the bottle-washing water.....	63
Figure 8:	Daily biogas yields of pre-treated and un-pretreated banana leaves.....	67
Figure 9:	Cumulative biogas yields of pre-treated and un-pretreated banana leaves.....	68
Figure 10:	Daily methane yields of pre-treated and un-pretreated banana leaves	69
Figure 11:	Cumulative methane yields of pre-treated and un-pretreated banana leaves.....	70
Figure 12:	Daily biogas yields of food wastes and food wastes supplemented with	73
Figure 13:	Cumulative biogas yields of food wastes and food wastes supplemented with edible clays soils	74
Figure 14:	Daily methane yields of food wastes and food wastes supplemented with edible clays soils.....	75
Figure 15:	Cumulative methane yields of food wastes and food wastes supplemented with edible clays soils	76
Figure 16:	Daily methane contents during anaerobic digestion of supplemented and non-supplemented food wastes with edible clays soils.....	77
Figure 17:	Environmental impacts of systems (a, b, c, d, e, f, g and h) without resources recovery	80
Figure 18:	Percentage contributions of the major substances to the impact categories	81

LIST OF PLATES

Plate 1:	Municipal solid waste stored at 15 m ³ storage container at Samunge market.....	28
Plate 2:	Fungal treatment of banana leaves wastes (a) Pasteurization, (b) Packaging (c) Inoculants (d) Incubation	31
Plate 3:	Mushrooms growth at different stages (a) Colonization, (b) formation of a pinhead and, (c) fruiting bodies.....	54

LIST OF ABBREVIATIONS AND SYMBOLS

AD	Anaerobic digestion process
As	Arsenic
BAU	Business as usual
BE	Biological efficiency
BL	Banana leaves wastes
BMP	Biomethane potential
BWW	Banana Winery Wastewater
C	Carbon
Ca	Calcium
CaO	Calcium oxide
CaCO ₃	Calcium Carbonate
CC	Capital Cost
Cd	Cadmium
CH ₄	Methane
Cl	Chlorine
C/N	Carbon to Nitrogen ratio
Co	Cobalt
COD	Chemical Oxygen Demand
CO ₂	Carbondioxide
COVID 19	Corona Virus Disease 19
CP	Composting
Cr	Chromium
Cu	Copper
°C	Degree Celcius
DCB	Dichlorobenzene
ECS	Edible clay soil
EDXRF	Energy Dispersive X-ray Fluorescne
EI	Environmental Impacts
ELECTRE	Ellimination and Choice Expressing Reality

FAO	Food and agriculture Organization
Fe	Iron
FOG	Fat oil and grease
FP	Fungal pre-treatment
FW	Food wastes
g	Gram
GAC	Granular activated carbon
H ₂	Hydrogen gas
H ₂ S	Hydrogen Sulfide gas
H ₂ O	Water
H ₂ SO ₄	Sulphuric Acid
ILCD	International Life Cycle Data system
IPCC	Intergovernmental Panel on Climate Change
ISO	International Organization for Standardization
K	Potassium
Kg	Kilogram
Km	kilometre
K ₂ O	Potassium oxide
KW	kilowatt
KWh	kilowatt-hour
LCA	Life cycle assessment
LCIA	Life Cycle Impact Assessment
LF	Landfilling
LFG	Landfill gas
MC	moisture content
Mg	Magnesium
ml	millilitre
mm	millimetre
Mn	Manganese

Mo	Molybdenum
MSW	Municipal Solid Waste
MW	megawatt
N	Normality
Na	Sodium
NaOH	Sodium Hydroxide
NH ₃	unionized ammonia
NH ₄ ⁺	ionized ammonia
NH ₄ (HCO ₃)	Ammonium Bicarbonate
Ni	Nickel
NM-AIST	Nelson Mandela African Institution of Science and Technology
NMVOG	Non-Methane Volatile Organic Compounds
NO _x	Nitrogen oxides
N, P, K	Nitrogen Phosphorus and Potassium Fertilizers
NPV	Net Present Value
OFMSW	Organic Fraction of Municipal Solid Wastes
OC	Operating cost
Pb	Lead
PB	Payback period
pH	Potential of hydrogen
PhD	Doctor of Philosophy
PG	Per capita waste generation rate
PM10	Particulate Matter of size less than 10 mm
P ₂ O ₅	Diphosphorus pentoxide
R	Reactor
RCL	Recycling
Se	Selenium
SN	Scenario

SO ₂	Sulphur dioxide
TAN	Total ammonia nitrogen
TE	Trace elements
TN	Total Nitrogen
TP	Total Phosphorus
TS	Total solids
TZS	Tanzanian Shillings
U	Uranium
UN-DESA	United Nations Department of Economic and Social Affairs
USA	United States of America
US\$	United State Dollar
VFA	Volatile Fatty Acid Accumulation
VS	Volatile solids
WHO	World Health Organization
w/w	Weight per weight
WWTP	Wastewater Treatment Plant
Zn	Zinc

CHAPTER ONE

INTRODUCTION

1.1 Background of the Problem

Municipal Solid Waste (MSW) management is still unsatisfactory in most cities worldwide despite the several efforts by various stakeholders to tackle it. In the literature, several ways are used to define MSW. It can be described as all solid wastes generated in community places, including; institutions, commercial and residential, excluding the hazardous wastes (Karak *et al.*, 2012). In developing countries, the generated wastes are rich in organics and have high Moisture Content (MC). Literature shows that in developing and developed countries, the MC of wastes ranges between 50-70% and 20-30%, respectively (Aleluia & Ferrão, 2016; Mohee *et al.*, 2015). These differences can be attributed to the differences in waste recovering programs. Whereas, recovering programs for organic waste are widely applied in developed countries, less is done in developing countries that leave higher amounts of organic waste collected for disposal (Mmereki *et al.*, 2016). Because of the high organic matter and MC of wastes, the anaerobic digestion process is a suitable treatment option for biogas production (Tan *et al.*, 2015). However, such potential for harvesting biogas in solid wastes remains poorly understood/exploited, consequently accumulating solid wastes in the environment.

Anaerobic digestion (AD) is a natural process in which microorganisms digest organic matter under anaerobic conditions. This process results in the formation of biogas typically composed of 50 - 75% methane (CH₄), 25 - 50% carbondioxide (CO₂), and other smaller amounts of hydrogen, hydrogen sulphide and ammonia (Surendra *et al.*, 2014; Kumar & Samadder, 2017). In an AD system, several groups of microorganism work interactively in the conversion of complex organic matter through a series of stages, namely; hydrolysis, acidogenesis, acetogenesis and methanogenesis. The anaerobic digestion process is complex when lignocellulosic based substrates are part of Organic Fraction of Municipal Solid Waste (OFMSW) and therefore, require pre-treatments before the AD process (Ariunbaatar *et al.*, 2014). For instance, in tropical countries such as Tanzania, several tons of unutilized banana by-products, including banana leaves, are generated daily (Padam *et al.*, 2014).

Banana leaves wastes are mainly generated at the markets due to their application as wrapping materials for food, clothes, clay pots and cultural applications (Kennedy, 2009). Since banana leaves are lignocellulosic, utilizing these wastes for energy recovery, such as biogas production, would require pre-treatment to enhance their digestibility. Banana leaves are suitable substrates for the AD process due to their abundance and most of its parameters, such as Carbon/Nitrogen (C/N) ratio, pH, volatile solids, energy potential, are within acceptable ranges for the AD process (Fernandes *et al.*, 2013; Jena *et al.*, 2017; Zhang *et al.*, 2013). Well-established, cost-effective methods such as the co-digestion of two or more substrates are available to enhance the AD process (Shrestha *et al.*, 2017). However, for a readily available lignocellulosic substrate such as banana leaves wastes which do not necessarily require co-digestion to improve parameters such as C/N ratio, pH or nutrient balance, different pre-treatment strategies would be required.

Different pre-treatment methods, including mechanical, thermal, chemical and biological treatment, are used to improve AD of lignocellulosic based OFMSW. Mechanical and thermal pre-treatments have the disadvantage of high power and heat requirements, especially when treating lignocellulosic-based OFMSW (Cesaro & Belgiorno, 2014). Some of the drawbacks of chemical pre-treatments include higher amounts of chemicals are required in large-scale biogas production, which may increase operating costs. On the other hand, biological pre-treatment is considered environmentally friendly and does not necessarily require chemicals and can be performed at mild conditions (Chaturvedi & Verma, 2013; Sari & Budiyo, 2014).

Among all the available biological pre-treatments, fungal pre-treatment (FP) using a white-rot fungi species such as *Pleurotus ostreatus* (oyster mushroom), *Ceriporiopsis subvermispora*, *Trametes versicolor*, *Coriolus versicolor*, *Phanerochate chrysopodium* and *Cyathus stercoreus* have been considered as most capable of degrading the lignin of the most lignocellulosic substrates and of enhancing their digestibility for their subsequent applications (Abdel-Hamid *et al.*, 2013; Rodríguez-Couto, 2017; Thomsen *et al.*, 2016). Previous studies indicated that the lignocellulosic substrates such as wheat straw and shore wood could be pre-treated with *P. ostreatus* to improve their digestibility and improve the AD process with a resultant increase of biogas and methane production (Albornoz *et al.*, 2018; Amirta *et al.*, 2016).

Food waste also forms a large composition of OFMSW in the wastes of developing countries

collected for disposal at the landfill or dumpsites (Arthur, 2015). Food Wastes (FW) is readily biodegradable and has the challenges of rapid acidification during AD due to Volatile Fatty Acids accumulations (VFA) (Xu *et al.*, 2014; Zhang & Jahng, 2012; Zhou *et al.*, 2018). One strategy to improve VFA consumption during anaerobic digestion of readily biodegradable waste is trace elements (TE) supplementation. It is believed that the addition of TE in the AD process can improve activities of enzymes, growth of methanogens and process stability of the AD system (Banks *et al.*, 2012; Feng *et al.*, 2010). In the anaerobic digestion of OFMSW, trace elements can be added through co-digestion of OFMSW with substrates rich in TE or through direct addition of external TE (Zhang *et al.*, 2015). Several materials rich in TE are available; such examples include readily available edible clay soils widely consumed by pregnant women (Mwalongo & Mohammed, 2013). Despite being rich in TE, the potential of edible clay soils to improve AD has never been tested. The general purpose of this research was to examine the strategies to improve anaerobic digestion of OFMSW with specific attention to banana leaves and food wastes. Sustainable MSW management can be described as the operation of MSW activities that reduces environmental risks and ensures economic growth and social progress of the community (Chang & Pires, 2015). Therefore, for implementing sustainable technologies, environmental, economic, and social welfare are the most critical aspects (Chen *et al.*, 2017). Therefore, this study also assessed the environmental impacts of AD in comparisons to the landfill and composting process. Also, the study evaluated the economic feasibility of the biogas plant for OFMSW in the Arusha City of Tanzania.

1.2 Statement of the Problem

Organic fraction of municipal solid wastes (OFMSW) contains a wide range of substrates, including lignocellulosic, which require pre-treatment before the AD process. One of such lignocellulosic substrates presents in OFMSW is banana leaves wastes (BL). Several pre-treatment methods for lignocellulosic OFMSW, including chemical and fungal pre-treatments before the AD process, are available. However, there is no study on the valorization of single BL waste fractions to edible mushrooms and biogas. Furthermore, pre-treatments with pure chemicals such as alkalis increases operation costs. Since most industries utilize chemicals such as alkalis with the resultant generation of alkaline wastewater, investigation on using industrial wastewaters for the pre-treatment of lignocellulosic OFMSW is required.

Recovering biogas from readily biodegradable wastes such as food wastes also require improvement. One such improvement is through trace elements (TE) supplementation during the AD process. Further investigation on the potential material rich in TE, such as edible clay soil, which has never been tested to improve AD, is still required. Edible clay soils are readily available in most places, and therefore, can easily be utilized during the AD process. Despite being beneficial for the biogas recovery, the AD process is likely to cause environmental impacts in both water, land and air. In most cities of the developing countries, there are limited studies on environmental analysis of AD and other treatment options that have been analyzed using credible tools such as life cycle analysis. Therefore, this study also examined and compared the environmental impacts of AD and other MSW management scenarios in the Arusha City of Tanzania. The study also assessed the economic feasibility of the Arusha Biogas plant.

1.3 Rationale of the Study

Banana leaves and food wastes form a significant component of organic fraction municipal solid wastes generated and collected for the disposal in most tropical countries, including Tanzania (Padam *et al.*, 2014; Omari, 2015). These wastes can be utilized in anaerobic digestion to recover biogas that can be used for various applications such as cooking and electricity generation. However, the banana leaves waste (BL) is lignocellulosic waste which requires pre-treatment before the anaerobic digestion process (AD'). On the other hand, food waste (FW) is readily biodegradable waste and faces the challenges of rapid acidifications. Nevertheless, the currently available strategies to improve the digestibility of the lignocellulosic based and readily biodegradable wastes fall short in several ways and require improvements. Thus, this necessitates examinations of new improving strategies capable of overcoming challenges associated with the AD of lignocellulosic based substrates such as BL and readily biodegradable waste such as FW. Utilization of the food and banana leave wastes in the anaerobic digestion process will help divert waste from the landfills and improve the environmental management of Arusha City and other cities in the developing countries with similar waste characteristics. For implementing sustainable technologies, environmental, economic, and social welfare are the most critical aspects (Chen *et al.*, 2017). Therefore, this study also assessed the environmental impacts of anaerobic digestion process in comparisons to the landfill and composting process. Also, the study evaluated the economic feasibility of the biogas plants for treating BL and FW in the Arusha City of Tanzania.

1.4 Research Objectives

1.4.1 General Objective

Examination of strategies to improve anaerobic digestion of organic fraction of municipal solid wastes and environ-economic analysis of municipal solid wastes management options.

1.4.2 Specific Objectives

- (i) To examine the effects of fungal (*Pleurotus ostreatus*) treatment of the banana leaves wastes towards edible mushrooms and biogas recovery.
- (ii) To assess the capacity/effectiveness of banana winery wastewater in digesting the banana leaves wastes to improve methane yield.
- (iii) To examine the potential of edible clay soils towards improving anaerobic digestion of food wastes for biogas recovery.
- (iv) To analyze and compare the environmental impacts of anaerobic digestion and other municipal solid waste management scenarios in the Arusha City of Tanzania.
- (v) To assess the economic feasibility of the biogas plant for MSW management in the Arusha City of Tanzania.

1.5 Research Questions

- (i) What is the effect of the fungal treatment of the banana leaves wastes on edible mushrooms and biogas recovery?
- (ii) What is the effect of the banana winery wastewater in digesting banana leaves wastes towards improving methane yield?
- (iii) What is the effect of edible clay soils on improving anaerobic digestion of food wastes for biogas recovery?
- (iv) What is the environmental effect of the anaerobic digestion process in comparison to other treatment options such as composting and the landfill?
- (v) Is it economically viable to manage municipal solid waste in Arusha with a biogas plant?

1.6 Significance of the Study

Organic fraction of municipal solid wastes in most cities of developing countries, including Tanzania, is a suitable feedstock for the AD process to recover biogas for energy and digestate for fertilizers. This study examined the strategies for an improvement of the AD process of organic fraction of municipal solid wastes. The thesis also evaluated environmental burdens associated with MSW treatment options and the economic feasibility of the biogas plant of the Arusha City of Tanzania. Such information on improving strategies is significant towards improving energy sectors and environmental management. Therefore, the study is contributing knowledge on how to manage MSW sustainably. Different stakeholders, including policymakers, engineers, entrepreneurs, waste managers, economists and others, can utilize this information for various applications, including; the decision-making process and implementation of sustainable MSW treatment options.

1.7 Delineation of the Study

Anaerobic digestion experiments require a long duration time for the complete digestion of OFMSW. Therefore, examining the strategies to improve the AD process has been carried out using only two substrates; banana leaves wastes (BL) and food wastes (FW). Banana leaves and food wastes were selected because they form a significant component of OFMSW collected for disposal. Moreover, most of the parameters on these selected substrates are suitable for the AD process. Whereas BL has the challenge of digestibility, FW, on the other hand, has the challenge of rapid acidifications. Therefore, the examined strategies in this thesis should also be tested in other OFMSW. The study didn't cover the microbial dynamics during the AD process. Therefore, future studies should focus on elucidating the microbial dynamics in response to improved strategies. The response of the microbial activities towards different improvement strategies for the AD will help increase knowledge on how to enhance the AD process.

CHAPTER TWO

LITERATURE REVIEW

2.1 Municipal Solid Wastes Generations and Compositions

Globally, it is projected that by the year 2025, more than 40% of the annual MSW generated will be organic, and the generation rate could reach over 2 billions tons (Kumar & Samadder, 2017; Pavi *et al.*, 2017). Of late, MSW causes a management burden for municipals, some of which fail to collect all the wastes produced (Sharma & Jain, 2020). Comparing available waste generation data between developed and developing countries shows that the generation rates are higher in developed than in developing countries (Kothari *et al.*, 2014; Zhang *et al.*, 2010). The generation also varies between cities and towns in both developed and developing countries. The global waste streams comprise six waste categories which include; organic (46%), paper (17%), plastic (10%), glass (5%), metal (4%) and others (18%) (Hoorweg & Bhada-Tata, 2012). The higher percentage of organics in the global waste stream suggests resources such as biogas and composts can be recovered from MSW to reduce the wastes that could otherwise end in landfills or dumpsites (Mmerekhi *et al.*, 2016). Since MSW has a high percentage of organic contents, the AD process can recover resources such as biogas for energy and digestate for fertilizers or organic amendment with less environmental repercussions.

2.2 The Anaerobic Digestion Processes

The AD process comprises a series of metabolic stages, including; hydrolysis, acidogenesis, acetogenesis, and methanogenesis, further described in this section.

2.2.1 Hydrolysis

This is the first stage of the AD process where complex higher-weight molecular compounds are decomposed into lower molecular weight compounds by hydrolytic bacteria. In this stage, fatty acids are converted from fats/lipids, amino acids from proteins and sugars from carbohydrates (Mitchell & Gu, 2010; Mir *et al.*, 2016). Biodegradation of the complex feedstock such as lignocelluloses materials is very slow, and therefore hydrolysis is considered as the rate-limiting step in anaerobic metabolic stages (Hagos *et al.*, 2016; Mitchell & Gu, 2010; Krishna &

Kalamdhad, 2014). The overall reaction in the hydrolysis stage is represented by Equation (1):



2.2.2 Acidogenesis

This is the second stage of the AD process where a large group of facultative and obligate anaerobic bacteria convert the products of hydrolysis into organic acids such as acetate, propionate, butyrate, alcohols, lactic acids and some inorganic compounds such as CO₂, H₂, H₂S and NH₃ (Zhou *et al.*, 2018). The presence of facultative bacteria that use oxygen that is known to be toxic to obligate anaerobes is significant to creating conducive conditions for obligatory anaerobes (Mir *et al.*, 2016; Krishna & Kalamdhad, 2014). Equations 2, 3 and 4 represent overall reactions (Mir *et al.*, 2016; Zhang *et al.*, 2015; Mitchell & Gu, 2010) in this stage:

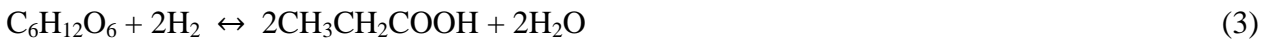

2.2.3 Acetogenesis

This is the third stage of the AD process, where acetogenic bacteria convert the products of acidogenesis into acetic acid, hydrogen and carbon dioxide. Equations 5, 6 and 7 represent overall reactions (Mir *et al.*, 2016; Zhang *et al.*, 2015; Mitchell & Gu, 2010) in this stage:

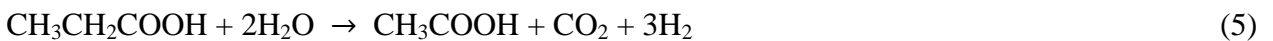

The first three stages of the AD process; hydrolysis, acidogenesis and acetogenic, are grouped as acid fermentation. In acid fermentation, the build-up of VFA occurs, which cause a decrease in pH, which affect the methanogenic process, which is the fourth stage and whose activity is best at near-neutral pH values (6.5-7.5). The build-up VFAs in acidogenesis and acetogenic phases are essential in assessing the performance and monitoring of the stability of AD processes (Atasoy *et al.*, 2018; Jiang *et al.*, 2013). The optimal pH range for the methanogens (6.5 -7.5) should be maintained to enhance the activities of these bacteria (Vögeli *et al.*, 2014; Ye *et al.*, 2013; Zhang

et al., 2015). Therefore, sufficient alkalinity is required during the AD process to avoid VFA accumulation that would inhibit the methanogenic process (Vögeli *et al.*, 2014).

2.2.4 Methanogenesis

In this final step of the anaerobic digestion process, the degradation of MSW and methane formation can be accomplished by two groups of bacteria. Acetotrophic methanogens which degrade acetic acid to methane (Equation 8), and hydrogenotrophic methanogens which use carbon dioxide and hydrogen to produce methane (Equation 9). Methane can also be formed from ethanol by substrate oxidation (Mir *et al.*, 2016; Zhang *et al.*, 2015; Mitchell & Gu, 2010) as per Equation 10:

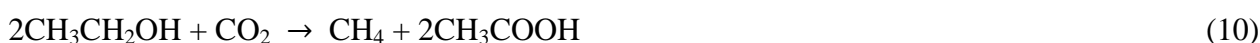
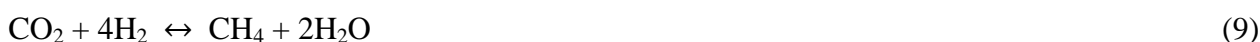

About 70% of methane is due to acetate degradation by acetotrophic methanogens and less than 30% is produced by hydrogenotrophic methanogens (Mir *et al.*, 2016). The reason for the lower contribution by hydrogenotrophic methanogens is attributed to limited hydrogen supply in AD systems.

2.3 Strategies to Optimize the Anaerobic Digestion Process of Municipal Solid Wastes

2.3.1 Hydrolysis Stage Optimization

The hydrolysis stage can be improved through different pre-treatment methods such as mechanical, thermal, chemical and biological (Izumi *et al.*, 2010; Mackul'ak *et al.*, 2012; Mustafa *et al.*, 2016). Table 1 summarizes some of the advantages and disadvantages of each pre-treatment technique currently used to improve the hydrolysis stages of AD of organic fraction of municipal solid wastes. The widely used mechanical pre-treatments such as maceration, sonication and high-pressure homogenizer have the drawback of high power requirements when treating lignocelluloses based OFMSW (Cesaro & Belgiorno, 2014). The thermal pre-treatment option is not viable at industrial application due to the high heat requirement. The use of chemical pre-treatments has the drawbacks of higher operating costs due to higher amounts of chemical

requirements and the formation of inhibitory products such as phenolic compounds, furans and carboxylic acids that may inhibit the methanogenic activities (Behera *et al.*, 2014). On the other hand, microbial pre-treatments are advantageous in terms of less corrosiveness and the formation of less harmful products due to the absence of chemicals (Mishra *et al.*, 2018; Wagner *et al.*, 2018).

In Tanzania specifically, several studies on microbial pre-treatments have been utilized for hydrolysis enhancements of OFMSW before the AD process (Muthangya *et al.*, 2009; Temu *et al.*, 2016). However, because of the heterogeneous composition of OFMSW, different specific enzymes may be required to degrade a different kind of OFMSW, and thus further studies are still needed (Cesaro & Belgiorno, 2014). Therefore, the current pre-treatment methods fall short in several aspects and require improvement. Future studies on improving the hydrolysis stage should involve investigating the new low-cost pre-treatment methods and; a combination of the different pre-treatment technologies and evaluation of their economic, environmental and technical feasibilities.

Table 1: Summary of advantages and disadvantages of pre-treatment strategies to optimize the hydrolysis stage

Strategy	Advantages	Disadvantages
Chemical	Pre-treatment with Alkali and acid facilitates lignin removal and consequently enhances better contact of microorganisms and substrates. At a small scale, biogas production chemical pre-treatment has low capital costs.	There is a possibility of forming inhibitory products such as phenolic compounds, furans, and carboxylic acids with chemical pre-treatments. At large scale biogas productions, chemical pre-treatment has high capital costs
Mechanical	Improved biogas production due to particle size reduction, which increases the surface area available of substrates with microorganisms. Mechanical pre-treatment of lignocellulosic based wastes facilitates rapid digestion	Drop-in pH due to excessive particle reductions resulting in VFA accumulations which lower methane yields. High energy requirements in pre-treatment of lignocellulosic based wastes.
Microbial	Enhances degradation of wastes by microorganisms due to lignin removal during pre-treatment. There is less corrosiveness and by-product formation due to no use or low application of chemicals. It can be applied in milder condition.	Microbial pre-treatment may take a long time to degrade lignocellulosic based OFMSW. Different specific enzymes may be required to degrade a different kind of OFMSW
Thermal	Thermal pre-treatment facilitates the removal of pathogens in substrates which promotes safe handling of by-products.	The process is costly due to high heating requirements.

2.3.2 Acidogenesis and Acetogenesis Stages Optimization

To improve acidogenesis and acetogenesis stages of the AD process, the literature recommends the addition of trace elements (TE) and Granular Activated Carbon (GAC) (Banks *et al.*, 2012; Dang *et al.*, 2017; Lee *et al.*, 2016; Wei *et al.*, 2014; Zhang & Jahng, 2012; Zhang *et al.*, 2011). Trace elements can be described as essential elements required to improve enzymes' activities for the proper growth of organisms (Wei *et al.*, 2014). In the anaerobic digestion process, TE can be added through direct addition of external trace elements or through co-digestion of organic fraction of municipal solid wastes with other substrates that are rich in TE. The addition of TE has been reported to improve activities of enzymes, growth of methanogens and process stability. On the other hand, the addition of GAC is believed to serve purposes such as immobilization of syntrophic microorganisms, adsorption of inhibitors, and promotion of direct interspecies electron transfer in the AD process (Baek *et al.*, 2018; Liu *et al.*, 2012; Luo *et al.*, 2015; Wang *et al.*, 2014). Table 2 summarizes the results of AD improvement upon TE and GAC supplementation. With an increasing desire to utilize MSW for resources recovery, further studies should identify more substrates that are rich in TE and understanding microbial response upon TE supplementation. Moreover, operating biogas plants with GAC requires very strict techniques and need further studies to make them feasible in developing countries.

Table 2: Summary of results of anaerobic digestion improvement upon trace elements and granular activated carbon supplementation

Strategy	Type of Feedstock	Influence of the Strategy	Reference
Direct supplementation of trace elements (Fe, Co, and Ni)	Food wastes	Direct supplementation of Fe, Co and Ni in food wastes allowed operations with high organic loads and maintained process stability	Wei <i>et al.</i> (2014)
Direct supplementation of trace elements (Se and Co)	Food wastes	Direct supplementation of Se and Co in food wastes resulted in stable process operation and increased methane yields	Banks <i>et al.</i> (2012)
Co-digestion	Co-digestion of food wastes (83%) and piggery wastewater (17%)	The mixture of piggery wastes rich in trace elements and food wastes prevented VFA accumulations and doubled methane production	Zhang <i>et al.</i> (2011)
Supplementation of coal-based granular activated carbon	Synthetic wastewater	Coal-based granular activated carbon enhanced biomass growth, acclimatization of microorganisms and consequently led to an increased methane production	Lee <i>et al.</i> (2016)
Supplementation of granular activated carbon	VFAs (acetate, propionate, and butyrate)	Granular activated carbon supplementation enhanced VFA degradation and increased methane yields	Xu <i>et al.</i> (2018)

2.3.3 Methanogenesis Stage Optimization

The Methanogenesis stage can be improved through different strategies such as blending of feedstock to achieve a favourable C/N ratio, acclimatization of inoculum, and TE optimization (Rajagopal *et al.*, 2013; Sun *et al.*, 2016; Zhang *et al.*, 2013). Ammonia inhibition is a major factor in the methanogenesis stage. At high concentrations, ammonia is toxic to microorganisms and is widely reported to inhibit methanogenic activities (Rajagopal *et al.*, 2013; Xie *et al.*, 2016). Different substrates have different C/N ratios (Table 3). These substrates can be appropriately blended to attain a recommended C/N ratio of 20-35 to counteracting ammonia inhibition (Hagos *et al.*, 2016). In aqueous anaerobic processes, ammonia exists in two principal forms; unionized ammonia (NH_3) and ionized ammonia (NH_4^+), which together form Total Ammonia Nitrogen (TAN) (Ji, 2017). The NH_3 and NH_4^+ exist in equilibrium and are reversible depending on temperature and pH. Whereas studies to optimize single parameters such as pH or temperature are widely available, studies to optimize and understand the relationship between temperatures, pH and ammonia concentration in the AD process are not comprehensive.

Table 3: Various materials with different carbon-nitrogen ratios

Materials	C/N ratio	References
Food wastes	3-17:1	Divya <i>et al.</i> (2014)
Kitchen refuse	6-29:1	Hagos <i>et al.</i> (2016) and Sorensen (2010)
Slaughterhouse wastes	3-37:1	Divya <i>et al.</i> (2014) and Sorensen (2010)
Fruits and vegetable wastes	7-35:1	Hagos <i>et al.</i> (2016)
Grass/grass trimmings	12-16:1	Divya <i>et al.</i> (2014) and Hagos <i>et al.</i> (2016)
Sewage sludge	13:1	Bustamante <i>et al.</i> (2013) and Sorensen (2010)
Cow dung	16-25:1	Divya <i>et al.</i> (2014) and Sorensen (2010)
Fish solid waste	17.16	Kassuwi <i>et al.</i> (2012)
Fallen leaves	50-53:1	Divya <i>et al.</i> (2014)
Rice straw	51-76:1	Divya <i>et al.</i> (2014), Rashad <i>et al.</i> (2010) and Sorensen (2010)
Wheat straw	50-150:1	Bustamante <i>et al.</i> (2013), Hagos <i>et al.</i> (2016) and Sorensen (2010)
Green waste	60:1	Nolan <i>et al.</i> (2011)
Straw	60-200:1	Nolan <i>et al.</i> (2011) and Sorensen (2010)
Maize straw	62:1	Bustamante <i>et al.</i> (2013)
Sawdust	200-500:1	Hagos <i>et al.</i> (2016), Nolan <i>et al.</i> (2011) and Sorensen (2010)

2.4 Resources Recovery from the Anaerobic Digestion of Municipal Solid Wastes

2.4.1 Utilization of Biogas as an Energy Source

In small scale production, biogas can be utilized to meet several requirements, including cooking, heating and lighting (Tumwesige *et al.*, 2014). On a large scale, biogas plants can use several types of organic wastes from the livestock waste, food-processing industry, sewage sludge and MSW to generate electricity (Shen *et al.*, 2015). Biogas applications can be extended to be used as transport fuel injected in natural gas pipelines, combined heat and power, and as a vehicle fuel upon purification to remove impurities such as CO₂, H₂S and water vapour (Dotzauer *et al.*, 2015; Shen *et al.*, 2015). In small scale applications, biogas can be used to replace or supplement the traditional cooking wood-fuel. This would therefore, help reduce the deforestation rate, specifically in sub-Saharan Africa, where people predominately use wood fuel for most of their cooking needs. Production of electricity in large scale biogas production can be a viable solution to circumvent the current problems of MSW and energy shortage.

2.4.2 Utilization of Digestate as Fertilizer or Soil Amendment

Most cities of the developing countries import chemical fertilizers making their usage costly (Semiyaga *et al.*, 2015). The continuous application of chemical fertilizers is also linked with soil degradation and environmental pollution (Koszel & Lorencowicz, 2015; Raimi *et al.*, 2017). Digestate (or effluent slurry) derived from the AD process is rich in nutrients such as nitrogen, phosphorus, potassium and can be used to supplement or replace chemical fertilizers (Islam *et al.*, 2010; Mukhuba *et al.*, 2018). The use of digestate as fertilizers or organic amendment depends on the amount of mineral nitrogen it contains. The digestate can be used as a fertilizer when a higher percentage of nitrogen is present in the digestate relative to organic fraction and can be used as an organic amendment when the mineral nitrogen is in lower per cent relative to the organic (Nkoa, 2014). Therefore, the promotion of valuable products from the AD process, such as digestate, positively contributes to improving waste management and the agricultural sector.

2.5 Environmental and Economic Benefits of Anaerobic Digestion of Municipal Solid Wastes

An environmental and economic evaluation of the AD process is crucial for its sustainability (Chen *et al.*, 2017). The AD systems are of tremendous importance in offering environmental and economic benefits. The findings by Woon *et al.* (2016) showed that FW converted into biogas can fuel vehicles as a petrol substitute and provide environmental services through the reduction of greenhouse gas emission. Similarly, Patterson *et al.* (2013) indicated that the utilization of biogas as vehicle fuel reduces carbon dioxide compared to diesel fuel. Khoo *et al.* (2010) investigated the environmental performance of FW conversion into energy through AD, incineration and composting technologies. The results showed that the AD system is more environmentally favourable regarding reducing global warming impacts than incineration and composting options. Untreated MSW may also lead to groundwater and surface water pollution, soil degradation and the spread of infectious diseases (Gebrezgabher *et al.*, 2010). All these problems can be curbed using the AD process to treat MSW to recover biogas and digestate.

The economic feasibility of utilizing AD to treat MSW can be assessed both socially and financially. Socially, AD treatment of MSW can lead to benefits such as treatment of wastes, reduced deforestation, and improved public health. This means that economic viability evaluation that focuses on the financial part only may result in weak conclusions on what AD treatment of MSW can achieve economically (Chen *et al.*, 2017). The financial viability of AD treating MSW should be evaluated by considering the substitution of fuels and fertilizers by biogas and digestate. In most developing countries, the prices of chemical fertilizers are high because they are imported and out of reach of many farmers (Semiyağa *et al.*, 2015). Such high costs can be avoided by using digestate from AD treating MSW resulting in considerable cash savings. However, in most countries, governments offer subsidies on chemical fertilizers, and AD fertilizers can be expensive alternatives to farmers (Ricker-Gilbert & Jayne, 2017). However, due to the additional social benefits offered by the AD process, equal subsidies on AD products need to be considered. Utilizing organic fertilizers from AD plants may lead to new employment opportunities for people who will work in the plants.

In an AD treatment of wastewater sludge, the energy recovered is self-utilized in the Waste Water

Treatment Plants (WWTPs) to achieve up to about 65% of the energy requirements (Bodík & Kubaská, 2013; Jenicek *et al.*, 2012). The WWTPs can achieve up to 100% of the total energy requirements when wastewater sludge is optimized through co-digestion with OFMSW due to increased biogas production (Hao *et al.*, 2015; Pavan *et al.*, 2013). The revenue from OFMSW gate fees and renewable energy are some of the financial incentives of the AD plants (Nghiem *et al.*, 2017). Therefore, optimizing the AD process can make the AD plants economically viable, but further cost-benefit analyses are required before fully committing them to large scale production.

2.6 Experiences with the Realization of Biogas Plants from other Countries

The realization of the biogas plants utilizing OFMSW and other wastes is well established in some of the developed countries (Cheng *et al.*, 2014). However, the experiences show that the realization of the biogas plants emerged due to the long-term efforts and struggles (Torrijos, 2016). For instance, in Denmark and Netherlands, the biogas industry began with farm-scale as early as the 1970s because of the energy crisis and the desire for the farmers to generate their source of energy (Bundgaard *et al.*, 2014). Therefore, energy production was the only focus, and manure was the only substrate utilized in the biogas plants. Years later, it was revealed that the biogas plants could provide multiple benefits, including stabilization of manure to fertilizer granules that could be sold to increase the revenue of the biogas plants. However, during that time, the technology was new and there were no established optimization strategies and therefore the farm-scale plants suffered from the low biogas yields which resulted in negative economic returns.

The challenges highlighted above spurred the establishment of the centralized biogas plants with the concept that it could increase the biogas yields and reduce the operating costs due to the economies of scales (Raven & Geels, 2010). In 1986, most of the established centralized biogas plants in European countries faced competition from the decreased oil prices. However, Denmark and other European countries decided to embrace biogas technology. Therefore, they raised the taxes on oil products and coal and granted tax exemptions on biogas and other renewable energy sources (Raven & Gregersen, 2007). Furthermore, Denmark increased its support to the biogas plants due to its multiple benefits in the energy, environmental and agriculture sectors.

In 1988, the Danish Energy Agency, the Environmental Protection Agency, and the Ministry of Agriculture established the biogas action program, which was fundamental for transferring the biogas technology (Raven & Geels, 2010). The biogas action program paved the ways for the provisions of the investments grants for centralized biogas plants and created the global research networks of biogas development activities. Through a long term experience and struggles, it was later revealed that a biogas plant could utilize several types of OFMSW to improve the biogas yield and generate electricity (Angelidaki & Ellegaard, 2003). Several large-scale biogas plants have been established in some European countries and the USA from this perspective.

For instance, the Rovereto wastewater treatment plant in Italy generated about 3900 kWh when only sludge was treated (Mattioli *et al.*, 2017). Upon co-digestion of the sludge with about 10.6 tonnes per day of OFMSW as co-substrate, the production doubled to 7800 kWh per day. This production was about 85% of the plant total energy demand. Moosburg WWTP in Germany is generating 380 kW of electricity from co-digestion of 100 tonnes per day of sludge as the primary substrate and 22 tonnes per day of pre-treated food waste (Nghiem *et al.*, 2017). Björn *et al.* (2017) indicated that through the co-digestion of OFMSW with primary and waste-activated sewage sludge, the biogas production from the Henriksdal WWTP in Stockholm resulted in a four-fold increase. East Bay Mud plant in the USA generates 11 000 kW of electricity from co-digestion of 2650 tonnes per day of sludge as primary substrate and 40 - 120 tonne per day of food waste and fatty oil grease (Nghiem *et al.*, 2017).

Some of the challenges associated with OFMSW in AD systems include; inert impurities such as glass, porcelain, plastic, bones, and seashells, which require particular attention during the collection and processing of wastes (Nghiem *et al.*, 2017). In sub-Saharan Africa, the development of large-scale biogas technology is still in its infancy. In South Africa, by the year 2017, about 38 commercial biogas projects produced about 50 to 70 Megawatt (MW) from different kinds of wastes, including; wastewater, process water, municipal wastes and manures (Laks, 2017). In Tanzania, the large-scale biogas development technology to produce electricity has not yet matured enough, although some efforts to generate electricity using this technology have been made. Currently, the Katani Biogas plant in the Tanga region produces about 150 kW of electricity from sisal wastes. Tanzania faces municipal and industrial wastes problems that can be addressed by large scale biogas technology to generate electricity. Several factors, including;

formations of vital stakeholder's networks of research institutions, technology suppliers, farmers, government ministries, banks and agricultural branch organizations, were crucial for realising the biogas plants (Raven & Geels, 2010). It can also be observed from Denmark and other European countries that the Governments played a crucial role in creating the enabling environments through policies that protected the biogas technologies to exist even during the struggle times (Torrijos, 2016).

2.7 Life cycle Analysis and its Utilization to Evaluate Environmental Impacts

The Life Cycle Assessment (LCA) tool is crucial for evaluating and comparing environmental burdens caused by different treatment options and the entire life cycle treatment of the activity, process, or product (Xu *et al.*, 2015). International Organization for Standardization (ISO) requires the life cycle studies to consider four main steps: Goal and scope definition, lifecycle inventory, life cycle analysis, and interpretation (ISO14040, 2006). With the LCA tool, extensive studies on environmental impact assessment of MSW have been conducted worldwide. However, because of the difference in locations, data used, system boundaries considered and nature of the wastes, different MSW technologies have been selected via the LCA tool that best suits the local conditions of the concerned area (Pires *et al.*, 2011). Therefore, such studies in other places cannot be generalized in other places where LCA studies are limited.

In Tanzania specifically, the LCA applications for MSW decision making are yet to be applied. There is no single study on LCA on MSW published in a peer-reviewed journal. Kazuva and Zhang (2019) assessed the best MSW treatment options in Dar es Salaam City, Tanzania using a multi-criteria analysis approach, "Elimination and Choice Expressing Reality (ELECTRE). The ELECTRE decision-making tool aids the decision-makers to select the best alternatives scenarios from several possible alternatives outranked by others (Akram *et al.*, 2019; Yu *et al.*, 2018). However, the study above focused only on CO₂ emissions as an environmental factor. Thus, further studies are required for correct interpretation since emissions such as methane, ammonia, nitrogen oxides, particulate matter, to mention a few are also likely to be impacted by MSW. Previous LCA study regarding MSW in Kampala city of Uganda could present a similar situation in Tanzania (Oyoo *et al.*, 2014). However, the study didn't consider several impact categories such as freshwater eutrophication, particulate matter formation and freshwater ecotoxicity, which are also

likely to be impacted by MSW. Therefore, the LCA studies are still required for a better decision-making process of the MSW technologies in Tanzania.

2.8 Key Findings and Knowledge Gaps

In this thesis, different strategies for improving the AD process with particular attention to the organic fraction MSW were reviewed. The key findings and identified gaps are summarized in the subsections below.

2.8.1 Key Findings

The followings were the key findings: (a) Different pre-treatment methods including chemical and biological are used to improve AD of lignocellulosic based OFMSW, (b) Chemical pre-treatment with alkalis and acids are effective for lignin removal and to enhance better contact of microorganism and substrates during the AD process, (c) Biological pre-treatments using a white-rot fungi species such as *Pleurotus ostreatus* (oyster mushroom) are considered as most capable of degrading the lignin of the most lignocellulosic substrates and of enhancing their digestibility for their subsequent applications, (d) The uses of trace elements and granular activated carbon have the advantages of counteracting volatile fatty acids inhibition to improve process stability, enhancing activities of enzymes and promoting the growth of methanogens, and (e) LCA studies on environmental impact assessment of MSW can not be generalized in other places where LCA studies are limited. This is because different results are obtained due to many factors including; data used in the analysis, decision to include or not to have equipment that causes emission, system boundaries considered, and local conditions of the concerned area.

2.8.2 Knowledge Gaps

The followings were the knowledge gaps: (a) Pre-treatment with pure chemicals such as alkalis or acids increases AD operation costs; this hinders its application in large biogas production. Future studies are required to investigate the low-cost pre-treatment strategies, and this may involve examining utilizing industrial wastewater that is generating alkaline or acidic wastewaters, (b) Due to the heterogeneous composition of OFMSW, different specific enzymes may be required to degrade a different kind of OFMSW. Thus, further studies are needed using a

white-rot fungi species such as *Pleurotus ostreatus* on potential substrates for AD that are yet to be tested, (c) Operating biogas plants with granular activated carbon is complicated and require high-level techniques. Therefore, future studies on granular activated carbon should identify new GAC materials and develop simple strategies to operate granular activated carbon in developing countries. Also, investigations are required on local and abundant materials rich in trace elements that may be used for improving methane generation, and (c) The LCA applications for MSW decision making are yet to be applied in Tanzania. Thus, LCA studies are required to make better decisions for implementing sustainable municipal solid waste management options.

CHAPTER THREE

MATERIALS AND METHODS

3.1 Examinations of the Effects of Fungal (*Pleurotus ostreatus*) Treatment of the Banana Leaves Wastes Towards Edible Mushrooms and Biogas Recovery

3.1.1 Materials

In this study, banana leaves (BL) wastes were utilized as a substrate for fungal treatment and biogas production. Banana leaves waste is part of the municipal solid wastes. It comprises 23.6% of organic market wastes generated at Arusha city food markets (Quantified under this study between May and September in the year 2019), as indicated in Fig. 1. Banana leaves wastes are mainly generated at the markets due to their application as wrapping materials for food, clothes, clay pots and cultural applications. The BL wastes used in this study were collected in woven bags from the Samunge food market in Arusha city, Tanzania. The BL wastes were manually sorted out from the mixed waste streams at the market before collection.

The BL wastes were then brought to the Nelson Mandela African Institutions of Science and Technology (NM-AIST) laboratory. They were chopped into 5-10 cm in length using a bush knife. The BL was further air-dried for seven days before characterization, and the fungal treatment work to reduce the waste's moisture contents. Fungal treatment of BL was carried out using the fungus *Pleurotus ostreatus* which was procured from the Sokoine University of Agricultural in Tanzania was used for the treatment of BL. The spawns were stored at 4 °C at the NM-AIST laboratory before using as per the standard storage technique for organic sample (Pognani *et al.*, 2012).

3.1.2 Characterization of the Banana Leaves Wastes for the Fungal Treatment

During characterization, a portion of BL was shredded into small pieces and then grounded with a mortar and a pestle. The most important parameters which affect the biogas productions were analyzed. The parameters analyzed were; Total Solids (TS), Volatile Solids (VS), pH, Carbon to Nitrogen ratio (C/N), Biomass Compositions (lignin, cellulose, hemicellulose), Trace Elements (TE), Volatile Fatty Acids (VFA), and alkalinity (Vögeli *et al.*, 2014). Total solids or total dry

matter of the substrates provide the measure of both biodegradable and non-biodegradable fraction of the substrates. Volatile solids or dry organic matter refers to the fraction of the substrates that can be converted into biogas (Vögeli *et al.*, 2014). The optimal pH in the range of 6.5 to 7.5 for the methanogens should be maintained to enhance the activities of these bacteria for high biogas yields (Ye *et al.*, 2013). During the AD process, the C/N ratio in the range of 20-35 is required for stable biogas production and counteracting ammonia inhibition (Hagos *et al.*, 2016).

Lignin, cellulose and hemicellulose are highly recalcitrant and provide the measure of how easily the substrates can be biodegraded by microorganism during the AD process (Kucharska *et al.*, 2018). The addition of trace elements in the AD systems plays significant roles in improving enzyme activities, growth of methanogens and stability of the anaerobic digestion process (Banks *et al.*, 2011; Habagil *et al.*, 2020; Maharaj *et al.*, 2021). The VFA and alkalinity values are essential for assessing the conversion of organic matter and buffering capacities of AD systems (Maragkaki *et al.*, 2018). Total Solids (TS), Volatile Solids (VS), and Moisture Contents (MC) were measured gravimetrically following standard methods for the examination of water and wastewater samples (American Public Health Association [APHA], 2012).

For pH determination of organic wastes, 10 g of the dried wastes were mixed with 100 ml deionized water and centrifuged for 15 min, then filtered through Whatman filter papers. The pH of the filtered solution was determined using a pH meter (HI 2209 pH/mV Meter). To determine the carbon to nitrogen ratio (C/N), the organic wastes samples were dried in an oven (Binder-Ed 53) at 70 °C for 24 h, and the dried samples were crushed and grounded into powders using mortars and pestles before sieving them to obtain fine powders. About 3.3 mg of each sample was analyzed for carbon and nitrogen using a C-H-N-S-O analyzer (Flash 2000 organic elemental analyzer) to obtain carbon to Nitrogen ratio in the sample. As described by Maryana *et al.* (2014), the Chesson method was used to determine lignin, cellulose and hemicelluloses of BL before and after pre-treatment.

With the Chesson method: (a) One gram of dry BL sample was refluxed for 1 h with 150 ml H₂O at 100 °C, (b) The mixtures were filtered and washed with 300 ml hot water and dried in the oven at 70 °C to a constant weight, (c) The dried residues were refluxed for 1 h with 150 ml of 1 N H₂SO₄ at 100 °C; the mixtures were filtered to neutral with 300 ml hot water and dried, (d) The

dried residues were soaked in 10 ml of 72% H₂SO₄ (v/v) at room temperature for 4 h. The resulting solutions were then diluted with 150 ml of 1 N H₂SO₄ and refluxed at 100 °C for 1 h. The residues were filtered and washed with 400 ml of hot water and dried at constant weight in an oven at 105 °C and weighed, and (e) Finally, the residues were ashed in a furnace at 575 °C for 4 h, and the resulting ashes weighed. The lignin, hemicelluloses and cellulose (LHC) compositions were determined as:

$$\text{Hemicellulose (\%)} = (b - c/a) * 100, \quad (11)$$

$$\text{Cellulose (\%)} = (c - d/a) * 100, \quad (12)$$

$$\text{Lignin (\%)} = (d - e/a) * 100 \quad (13)$$

The trace elements in BL were analyzed before and after the fungal treatment at Tanzania Atomic Energy Commission, Arusha, Tanzania, using the Energy Dispersive X-ray Fluorescence technique (EDXRF) (Spectro Xepos, serial No. 4R0138, operated by X-lab Pro™ software). Some portion of the chopped and dried banana leaves were stored at -20 °C to maintain their characteristics before the anaerobic digestion process (Pognani *et al.*, 2012). The Kapp method (Buchauer, 1998; Mota *et al.*, 2015) was used to determine the volatile fatty acids (VFA) concentrations and alkalinity values. The Kapp method is the titration method and was selected because it required only a burette for titration available in the laboratory. Statistical analyses for the means differences in trace element composition of the fungal treated and un-treated samples were conducted using a T-test in Microsoft Excel 2010. Three replicates were used for each sample, and results are expressed as mean and standard deviation.

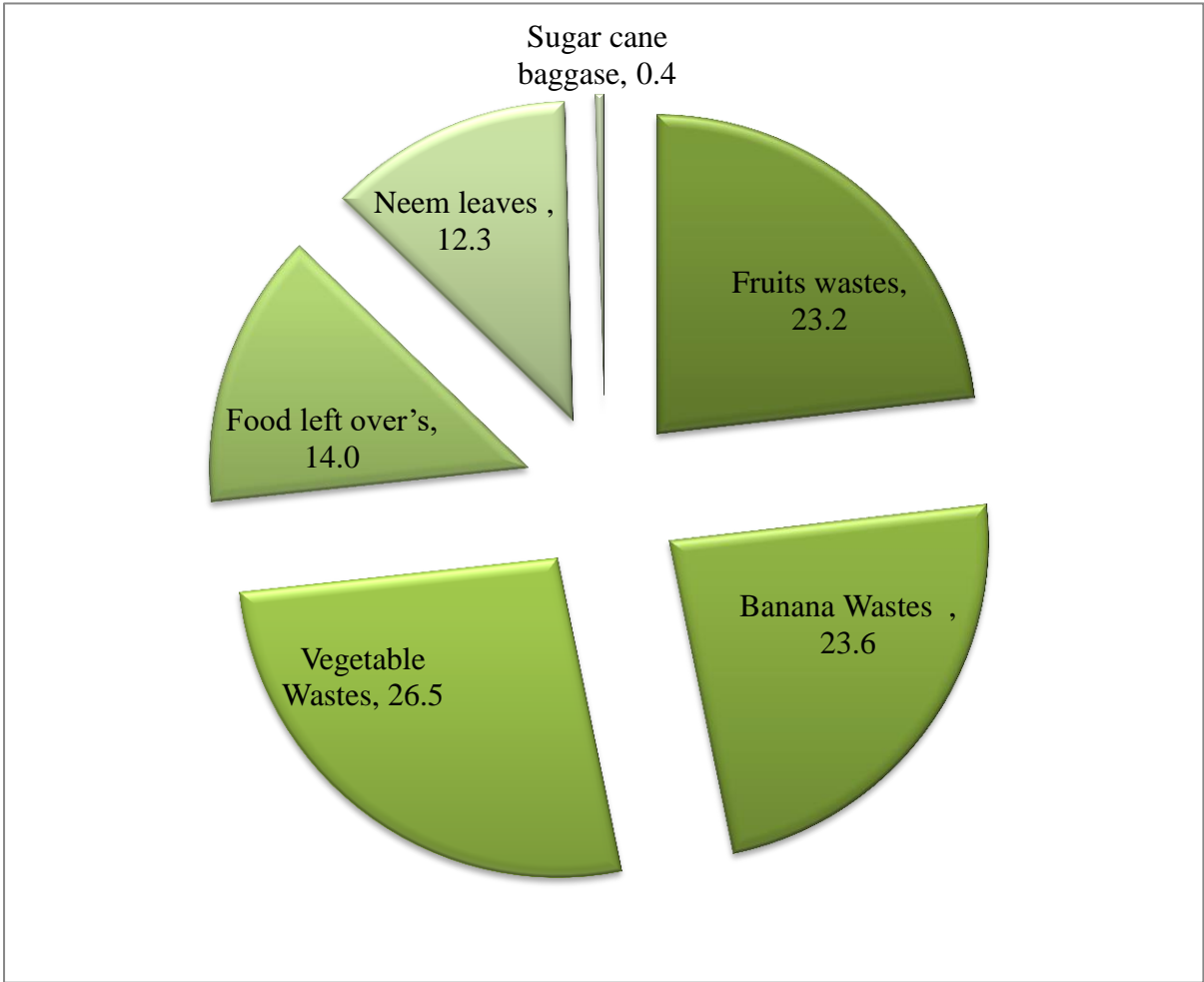

Figure 1: Organic fraction market wastes compositions at Samunge market



Plate 1: Municipal solid waste stored at 15 m³ storage container at Samunge market

3.1.3 Fungal (*Pleurotus ostreatus*) Treatment of Banana Leaves Wastes

Fungal treatment was performed in the treatment hut, which was locally constructed using the tree barks and covered at the top with the coconut leaves to keep the temperature below 25 °C recommended for *P. ostreatus* growth (Tesfaw *et al.*, 2015). Generally, the treatment involved pasteurization, spawning running (colonization) and formation of the fruiting bodies. Before pasteurization, the BL (5-10 cm) were soaked in water for two hours to soften it and was left to drain until no water was dripping from the substrates (Raymond *et al.*, 2013).

(i) Pasteurization

The drained substrates were placed in layers into woven sacks sheets and pasteurized into 0.225 m³ metal drums with a platform of stones with sieves at the top to the height of 18 cm from the bottom. Firewood was used as the fuel source, and for one batch of pasteurization for three hours, one bundle (15 kg) of firewood was used. About 20 l of water was poured inside the drum, the substrates were placed on the top of the platform, and the drum was covered with a metal lid. The pasteurization process took about 3 h, as reported in the literature (Raymond *et al.*, 2015). The temperatures inside the drum were measured using an infra-red thermometer (WT900, from -50 °C to 950 °C). The temperature inside the pasteurization drum varied from 92 to 124 °C. The pasteurized substrates were allowed to cool and drain inside the drum for one day.

(ii) Spawning Running

Transparent polyethene sheets were used as packaging materials for the cooled pasteurized substrates. About 2 kg of the loosely pasteurized substrates (corresponding to 490 g dry weight) were inoculated with *P. ostreatus* strain. The inoculation with *P. ostreatus* strain was done at the spawning rate of 7% (corresponding to 140 g of the spawns per 2 kg of the pasteurized substrates) at the top and both sides inside the polyethene sheets. Previous results on fungal treatment with *P. ostreatus* on wheat straw at the spawn rate ranging from 6 to 10% indicated that the spawn rate of 7% provided the optimal results for the maximum number of the fruit bodies formation and yield (Bhatti *et al.*, 2007). A total of 10 bags were used in this experiment. The already packed spawn substrates were incubated on wooden shelves disinfected with antibacterial sprays (Dettol) in the pre-treatment hut. To ensure enough darkness was available for spawn running, dark clothes were used to cover the spawned bags. The spawn running was complete when the inoculated substrates bags were fully colonized with mycelia formation (Tesfaw *et al.*, 2015).

(iii) Pinhead and Fruiting Bodies Formation

Light and relative humidity are pre-requisites for pinhead initiation and fruiting bodies formation after the completion of the spawn running (Tesfaw *et al.*, 2015). To ensure enough light and humidity, the dark clothes covering the spawned bags were removed, and tiny holes were made

into the bags using a syringe needle, and clean water was sprayed once a day to the spawned bags. Temperature and humidity were measured using a pocket weather meter (kestrel 3000). They were kept at an average temperature of 22 °C and 70 to 85% humidity per required optimal conditions as reported in the literature (Mustafa *et al.*, 2016; Wan & Li, 2012). The fruiting bodies were picked after they were developed from the pinheads. Details, including yields and biological efficiency, were determined after the harvest of the edible mushrooms. Biological efficiency, which is the measure to assess the growth potential of mushrooms, was determined as the percentage ratios of the fresh mushrooms harvested to the weight of the dry substrates (Vieira & de Andrade, 2016). The treated substrates were then characterized and subjected to the anaerobic digestion process.



Plate 2: Fungal treatment of banana leaves wastes (a) Pasteurization, (b) Packaging (c) Inoculants (d) Incubation

3.1.4 Anaerobic Digestion of Fungal Treated and Un-treated Banana Leaves Wastes

Anaerobic digestion process for biogas production of the fungal treated and un-treated banana leaves was carried out in batch reactors. The batch reactor with cow dung inoculum was treated as the control experiment. The other two batch reactors contained the fungal-treated and un-treated banana leaves, which were ground and sieved to 2 mm. Due to the nature of the batch reactors used, the AD process was operated in a wet state of which the total solid (TS) was kept

below 16% (Vögeli *et al.*, 2014). The TS of 9.6% and 9.7%, respectively, in the fungal treated and un-treated banana leaves, were obtained through mixing 20 g of the grounded BL and 400 ml of cow dung. The TS in a cow dung inoculum was kept at 6.1% through mixing 2:1 (w/w) water and cow dung.

The cow dung was collected in a closed bucket from the Roman Catholic Church cattle hut beside the NM-AIST Campus in Arusha, Tanzania. All experiments were performed duplicated in a 500 mL Erlenmeyer flask with an effective volume of 350 mL. The batch reactors were sealed with rubber stoppers and were incubated in a water bath for 40 days at 37 °C. The mesophilic temperature of 37 °C was maintained using a temperature controller in a water bath. The reactors were gently stirred three times a day for about 2 min to keep a uniform mixture and in order to avoid scum formation which is not required in AD process (Vögeli *et al.*, 2014). The volume of the biogas produced was collected by displacement of water (Fig. 2).

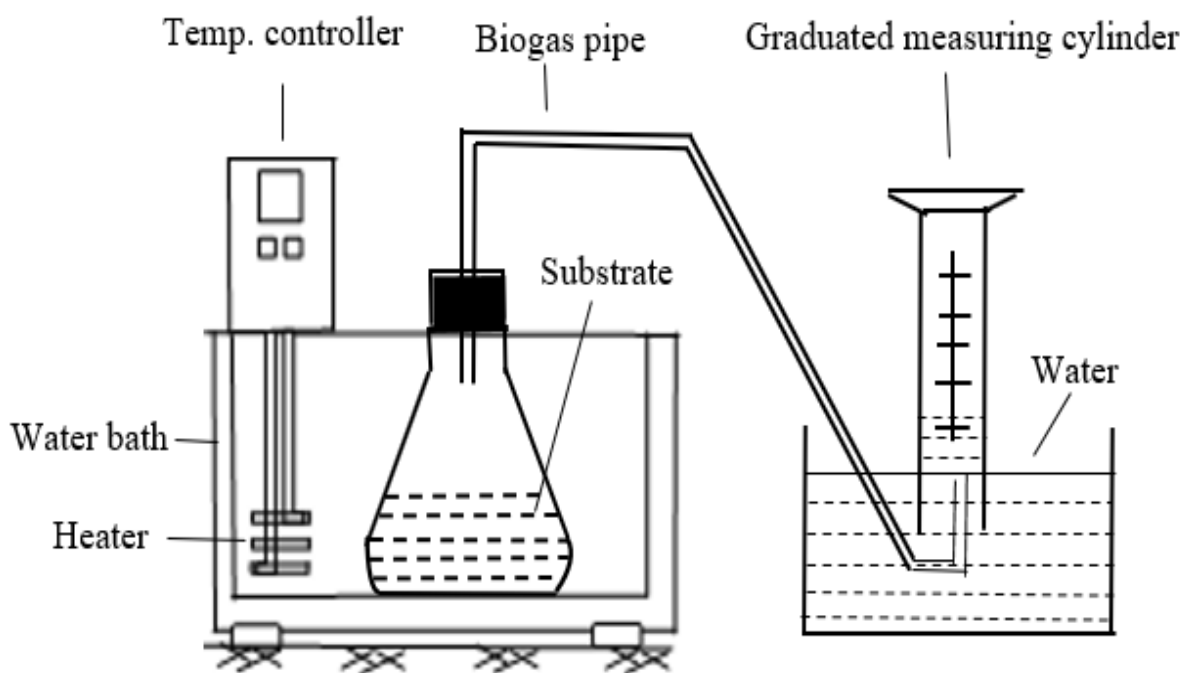

Figure 2: Experimental layout for biogas lab digester

3.2 Assessing the Effectiveness of Banana Winery Wastewater in Digesting the Banana Leaves wastes to Improve Methane Yield

3.2.1 Banana Leaves and Bottle Washing Water Samples

Arusha food markets generate about 18% (23.6% of organic waste) of BL from several activities such as carrying clay pots and ripening bananas (Quantified under this study in May and September 2019). The BL wastes are usually collected for disposal at the Muriet landfill, with the other municipal solid wastes (MSW) generated. In this study, the BL was sorted out from mixed MSW at Samunge food market in Arusha city, Tanzania, parked in woven bags and brought to the Nelson Mandela African Institutions of Science and Technology (NM-AIST) laboratory. Before the pre-treatment and anaerobic digestion process, the BL was air-dried to reduce the moistures contents and were put in dry storage before the pre-treatment process. To investigate the influence of alkaline wastewater from the banana wine industry, the bottle-washing water was collected in a closed container at the drainage bottle-washing units from Raha Beverages Company limited, Arusha, Tanzania (3° 23' 17.2932" S, 36° 43' 1.5204" E). The caustic soda (NaOH) is used to wash the spent banana wine bottles resulting in alkaline wastewater from the washing process. To understand the average characteristic of the bottle-washing water, the samples were collected and analyzed for the pH and Chemical Oxygen Demand (COD) in August 2020.

3.2.2 Feedstock Characterization

During characterization, some portions of BL were chopped into small pieces and grounded to 2 mm. Total solids (TS) and volatile solids (VS) were determined gravimetrically according to the standard methods for the examination of water and wastewater samples (APHA, 2012). A C-H-N-S-O analyzer (Flash 2000 organic elemental analyzer) was used to determine the carbon to nitrogen (C/N) ratio. A pH meter (HI 2209 pH/mV Meter) was used to determine the pH values. Energy Dispersive X-ray Fluorescence Technique (EDXRF) (Spectro Xepos, serial No. 4R0138, operated by X-lab Pro™ software) Tanzania Atomic Energy Commission, Arusha, Tanzania was used to analyze metal elements in BL. The volatile fatty acids (VFAs) and alkalinity values were determined according to the method described by Kapp (Mota *et al.*, 2015). Biomass compositions (lignin, cellulose and hemicelluloses) were determined according to the Chesson method (Datta, 1981; Maryana *et al.* 2014).

3.2.3 Pre-treatment of Banana Leaves

The pre-treatment of BL were performed at room temperature (22 °C) for 48 h using a 20-litre

closed bucket of which a mixture of 1:10 (w/w) BL and the bottle-washing water from the banana wine industry was selected for complete soaking of BL. Due to the limitation of the biogas equipment, the pre-treatment conditions were based on previous alkaline conditions in the literature that offered the best results (Chaiyapong & Chavalparit, 2016; Vazifekhoran *et al.* 2018). After 48 h of the pre-treatment, BL was dried in an oven (Binder-Ed 53) at 70 °C for 24 h, and the dried samples were ground using a grain milling machine (TK-MF 150) and sieved to 2 mm sizes before the anaerobic digestion process.

3.2.4 Anaerobic Digestion Process

The batch experiments for the biogas production were carried out in triplicate using a 500 mL Erlenmeyer flask with an effective volume of 350 mL and headspace equal to 150 mL. The batch reactors were operated at a wet state of which the TS of 8.09% and 8.45%, respectively, for the pre-treated and un-pre-treated BL, were obtained through mixing 17.5 g of the grounded BL and 350 ml of cow dung. The TS in a cow dung inoculum was kept at 5% through mixing 2:1 (w/w) water and cow dung inoculum. The inoculum was obtained free from the Church cattle hut besides NM-AIST Campus in Arusha, Tanzania. After adding the substrates and inoculum, the reactors were sealed at the top with rubber stoppers, and the outlet pipe from the reactors was connected to the IL biogas bags (Tedlar bags). The reactors were then placed in a water bath (Mettmert GmbH + Co. KG) and operated under the mesophilic temperature of 37 °C for 60 days. The gentle stirring of the reactors was done manually three times a day, and the volume of the gas was collected using a water displacement method. The biogas composition was analyzed using a biogas analyzer (Geotech biogas 5000 analyzer). The layout for the experiment is shown in Fig. 2.

3.3 Examination of the Potential of Edible clay Soils towards Improving Anaerobic Digestion of Food Wastes for Biogas Recovery

3.3.1 Food Wastes and Edible Clay Soils Samples

The food waste (FW) used in this study was collected from the canteen at the Nelson Mandela African Institution of Science and Technology (NM-AIST). It was composed of cooked food (60% rice, vegetables 30% and 10% potatoes). Inert materials such as bones were manually

sorted out from the FW, then FW was homogenized in a blender at an approximate size of 3 mm. The cow dung was obtained from the Roman Catholic Church at the NM-AIST, Arusha, Tanzania. The cow dung was diluted with tap water to approximately total solids of 5%. The edible clay soil rich in trace elements (ECS) were collected from the Tengeru market of Arusha, Tanzania (3.3729° S, 36.7863° E). Although pregnant women in Tanzania widely consume edible clay soils, they contain metal elements including Iron, Zinc, Selenium, Manganese, Arsenic, Lead, Cobalt, above WHO acceptable standards for human consumptions (Mwalongo & Mohammed, 2013). Thus, alternative use of edible clay soils for improving anaerobic digestion performance could be cost-effective than utilizing individual commercial trace elements.

3.3.2 Food Wastes and Edible Clay Soils Characterization

Total solids (TS) and volatile solids (VS) of the substrates were measured gravimetrically according to the standard methods for the examination of water and wastewater samples (APHA, 2012). The carbon to nitrogen ratio (C/N) was analyzed using an Element (C-H-N-S-O) analyzer (Flash 2000 organic elemental analyzer). The pH values were determined using a pH meter (HI 2209 pH/mV Meter). The elements analysis in edible clay soils were performed using the Energy Dispersive X-ray Fluorescence Technique (EDXRF) (Spectro Xepos, serial No. 4R0138, operated by X-lab Pro™ software) at Tanzania Atomic Energy Commission, Arusha, Tanzania. The Kapp method (Buchauer, 1998; Mota *et al.*, 2015) was used to determine the volatile fatty acids (VFA) concentrations and alkalinity values.

3.3.3 Batch Experiments

Anaerobic digestion process for biogas production was carried out in two 10 Liters capacity batch reactors made of stainless steel with a heating metal element for temperature adjustment and stirrer controller (Fig. 3). The reactors operated under mesophilic temperatures of 37 °C for 35 days and were stirred three times a day for about 10 min by the motor-driven agitators installed in the reactors during the whole experimentation period. Biogas was collected in the 10-litre biogas bags (Tedlar bags), and the composition of the gas was analyzed by the biogas analyzer (Geotech biogas 5000 analyzer).

The batch reactors were operated at a wet state with an effective volume of 7 liters. The TS of

6.3% was obtained through mixing 500 g of the FW added with 10 liters of cow dung inoculum. The TS in a cow dung inoculum was kept at 5% through mixing 2:1 (w/w) tap water and cow dung inoculum. To investigate the effect of edible clay soil rich in trace element supplementation, the feedstock in batch reactor 2 consisted of 96% (500 g) FW and 4% (21 g) edible clay soils. Edible clay soil supplementation rate of 4% was chosen to avoid the variations in Totals solids concentrations between the two batch experiments operated in wet state conditions and TS of 6.3%.

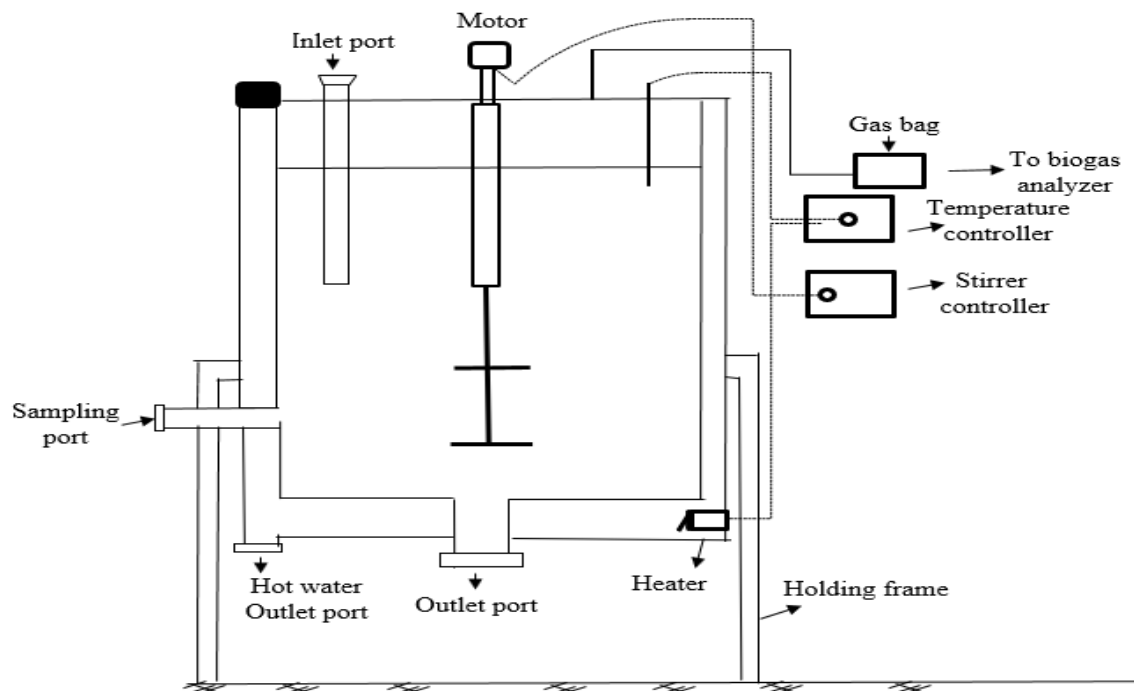

Figure 3: Schematic layout for the biogas biodigester

3.4 Analysis of the Environmental Impacts of Anaerobic Digestion and other Municipal Solid Waste Management Scenarios in the Arusha City of Tanzania

3.4.1 Municipal Solid Waste Management in a Study Area

Arusha city is located in the northeast of Tanzania and is divided into 25 wards, of which the collection of municipal solid wastes is made. In Arusha city, the private companies and the community-based organization collect the municipal solid wastes (MSW) from 25 wards and transport the wastes to the Muriet sanitary landfill for disposal. The Muriet landfill site is allocated about 6.5 km from the City Centre and started its operation in January 2019. This newly constructed landfill has the provisions for the Landfill gas collection and leachate collections.

About 400 registered waste pickers do the separation and collection of the recyclable materials at the landfill and sell them at nearby landfill pre-processing centres.

Table 4 indicates the purchase and sale prices of the recyclable materials as was found at Maendeleo pre-processing centre and other preprocessing centres in Arusha city. The city generates about 271 tons per day with waste compositions of 67% organic, 11% papers, 7% plastics, 6% textiles, 4% glass, 4% ashes and 1% metals, with an average moisture content of 59.79% (Omari *et al.*, 2014). The high organic content suggests that biological treatment options such as composting and anaerobic digestion would be suitable for life cycle analysis in this city. Other proposed treatment facilities such as composting and anaerobic digestion are also assumed to occur at the same site. The landfill record showed that the average total MSW collected in the year 2019 was approximately 182 tons/day, which is about 67.16% of the total waste generation.

Market waste comprised about 14 tons/day, which is approximately only about 7% of the total wastes generated. This study agrees with the findings reported by several studies, which indicated that market waste contribution to the MSW of developing countries ranges between 4 to 30% (Miezah *et al.*, 2015; Nabegu, 2010; Okot-Okumu, 2012). Muriet landfill receives MSW from 24 wards of the Arusha city council (Table. 5), of which in Terrat ward, which is a typical rural set up with scattered houses, the collection is rarely done. The per capita waste generation rate (PG) in kg/day/person for MSW of Arusha city was computed based on the population and daily MSW quantity generated in the year 2019 (Oumarou *et al.*, 2012; Palanivel & Sulaiman, 2014) as per Equation 14 :

$$PG = \frac{(\text{waste generation/day})}{\text{population}} \quad (14)$$

According to the world urbanisation population projection, Arusha city has an estimated population of 482 609 in the year 2019 (United Nations Department of Economic and Social Affairs [UN-DESA], 2017). Therefore, based on this information, the resulting per capita generation rate is approximately 0.56 kg/capita/day. This study relied on data collected in the year 2019 since there was an improvement in MSW management activities with reliable recording tools such as the weighbridge and an automated recording software at Muriet landfill.

Table 4: Purchasing and selling price of the recyclable materials at pre-processing centres

Materials	Purchasing Price (TZS) per kg	The selling Price of Pre-Processed materials (TZS) Per kg	Expected Final Products after Processing
Plastic bottles	200	600	Fibres for carpets, apparel, bottles, textiles and sheets products, washbowls, buckets, shampoo bottles, shopping bags
Hard plastics	400	900	Woven mat, plastic buckets, rollers
Woven plastic bags	250	500	Woven plastic bags
Bones	250	500	Animal foods
Cardboard boxes	50	220	Tissue papers, new cardboard

Table 5: Municipal solid wastes collection in Arusha wards

WARD	Quantity (tons/day)	Ward	Quantity (tons/day)
Baraa	4.00	Osunyai	8.85
Daraja II	2.10	Sakina	6.20
Elerai	6.07	Sekei	2.72
Engutoto	3.44	Sinoni	12.27
Kati	12.22	Sokoni 1	17.15
Kimandolu	6.54	Sombetini	9.70
Lemara	5.92	Themii	15.51
Levolosi	17.38	Unga LTD	6.51
Muriet	8.31	Moshono	3.48
Ngerenaro	5.22	Moivaro	1.58
Olasiti	7.69	Kaloleni	7.04
Olmot	4.20	Terrat	-
Olorien	8.02		

3.4.2 The Life Cycle Assessment Methodology

The Life Cycle Assessment (LCA) of the study was conducted as per the methodology described in ISO 14040. The ISO 14040 LCA methodology considers four main steps: Goal and scope definition, lifecycle inventory, life cycle analysis, and interpretation. The ReCiPe 2008 Midpoint (H). The V1.13 method was used to calculate the results because Umberto LCA+ software used in the analysis used the Eco invent version 3.6, of which ReCiPe 2008 is one of the few updated methods.

(i) Goal and Scope Definition

This study aimed to analyze and compare the impacts on the environments due to MSW waste management scenarios by using the life cycle methodology to promote a more suitable waste management option. The life cycle considered is the end of the life phase of which materials becomes wastes when their values cease and therefore are collected for treatment and disposal. In the analysis, the “zero burden assumption” was considered of which upstream environmental

burdens were not included in the analysis. Upstream environmental burdens refer to the previous life cycle phases of the product material before it became waste. The functional unit considered to analyze and compare the alternative scenarios is based on one metric ton of MSW of Arusha city, Tanzania. In this study, two new proposed scenarios and existing scenario (business as usual) for MSW practices of Arusha, Tanzania, were analyzed and compared.

Figure 4 shows the system boundary, including MSW, inputs of materials and energy, and outputs like air and water emissions, fertilizers (compost and digestate), electricity generated from anaerobic digestion and landfilling process. The recyclable materials are placed outside the system boundary, and their emissions are excluded in the analysis. This is because they are common to all scenarios and the consumers of the recycled scraps bear the burdens of recycling activities. Based on this proposed system boundary, Table 6 depicts the summary of the scenarios studied. Scenario (SN-1): This business as usual (BAU) (RCL_LF) Scenario presents currently practice for the MSW management in Arusha city of Tanzania. The MSW collected in the city are transported for disposal at Muriet Landfill, whereas the waste pickers recover recyclable materials (14.2%) including paper/cardboard, metals, plastics and glass and the rest of the wastes (85.8%) are landfilled. Currently, there is no operating burn unit for reducing the volume of the wastes that are landfilled. Since the Muriet landfill is nearing people residences and has approximately 400 registered waster pickers, the burning units are also excluded in the proposed alternatives since they could have immediate effects on people's health.

Scenario (SN-2): This scenario (RCL_CP_LF) assumes recyclable materials (14.2%) are recovered by waste pickers as per current status, but 67% which is organic wastes are composted, and the residue wastes (18.8 %) are landfilled. The composting process is assumed to be carried out in a batch-wise operation where the wastes will be placed in large piles, and turning of the windrows will be accomplished using the turning machines. Scenario (SN-3): This scenario (RCL_AD_LF) assumes recyclable materials (14.2%) are recovered by waste pickers as per current status, but 67% which is organic wastes is treated in the anaerobic digestion process, and 18.8 % of the residue wastes are landfilled. Following Igoni *et al.* (2008), the batch digester systems are recommended for biogas production from a huge amount of MSW since they are very economical in terms of operations. For this economic reason, the study considered the anaerobic digestion process to occur in a batch process. Due to the high moisture content

(59.79%) of Arusha MSW, the waste incineration option was not considered.

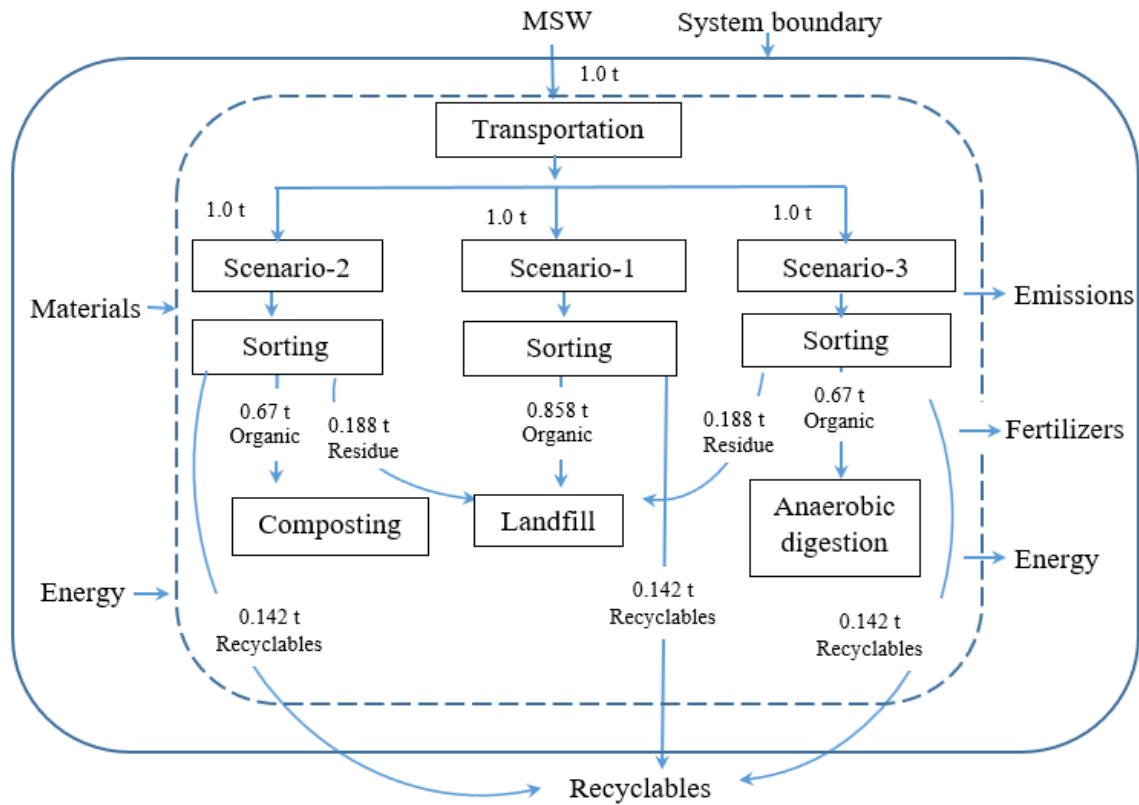

Figure 4: The system boundary of the study

Table 6: Description of the considered scenarios for the life cycle assessment

Scenario	Description
SN-1 (BAU) (RCL_LF)	14.2% Recycled (1.6% glass, 0.8% metals, 5.5% papers, 6.3% plastics) + 85.8% Landfilling (67% organic, 8% ashes, 2.4% glass, 0.2% metals, 5.5% papers, 0.7% plastics, 2% textiles)
SN-2 (RCL_CP_LF)	14.2% Recycled (1.6% glass, 0.8% metals, 5.5% papers, 6.3% plastics) + 67% Composting (67% organic) + 18.8% Landfilling (8% ashes, 2.4% glass, 0.2% metals, 5.5% papers, 0.7% plastics, 2% textiles)
SN-3 (RCL_AD_LF)	14.2% Recycled (1.6% glass, 0.8% metals, 5.5% papers, 6.3% plastics) + 67% Anaerobic Digestion (67% organic) + 18.8% Landfilling (8% ashes, 2.4% glass, 0.2% metals, 5.5% papers, 0.7% plastics, 2% textiles)

SN: Scenario, BAU: Business, as usual, RCL: Recycling, LF: Landfilling, CP: Composting, AD: Anaerobic digestion

(ii) Life Cycle Inventory

Inventory data related to the study were calculated through various means, including; personal calculations from municipal solid waste compositions of the study area, personal communications with Eng. Marco Chacha and Eng. James Lobikoki who are responsible for MSW management of Arusha City, on-site investigations at the landfill, markets places, MSW pre-processing centres and various published works of literature. The Umberto LCA+ software library and ecoinvent 3v6 database (Accessed from Michigan server of USA) were used to supply the rest of the information necessary for this study. Table 7 indicates the inventory data under each scenario used in this study (Abduli *et al.*, 2011; Babu *et al.*, 2014; Boldrin *et al.*, 2009; Hong *et al.*, 2010; Kaza & Bhada-Tata, 2018; Oyoo *et al.*, 2014; Rajaeifar *et al.*, 2015; Sharma & Chandel, 2017).

Table 7: Inventory data under each scenario per ton of municipal solid wastes

Parameters	Foreground data Emissions				Ref.
	Unit	SN-1	SN-2	SN-3	
Nitrogen oxides (NO _x)	g	7.44	39.40	127.30	
Total Nitrogen (TN)	kg	2.85			
Total Phosphorus (TP)	kg	4.50			
Particulates, < 2.5 um	g	0.75	0.75	0.20	Rajaeifar <i>et al.</i> (2015)
Sulphur dioxide (SO ₂)	g	0.17	0.17	2.01	
Methane (CH ₄)	kg	55	0.83	8.98	This study
Ammonia (NH ₃)	g	3.35	1271.2	714.00	This study
Parameters	Background data				Ref.
	Unit	SN-1	SN-2	SN-3	
Electricity consumption	kW h	0.42	-	2.95	Hong <i>et al.</i> (2010) and Rajaeifar <i>et al.</i> (2015)
Diesel	L	2.574	0.8789	0.564	Babu <i>et al.</i> (2014) and, Sharma and Chandel (2017)
Parameters	Avoided products				Ref.
	Unit	SN-1	SN-2	SN-3	
Electricity	kW h	43.55	-	137.3	Kaza and Bhada-Tata (2018) and
Fertilizer (N)	kg	-	0.34	0.	Boldrin <i>et al.</i> (2009)
Fertilizer (P)	kg	-	0.40	0.22	Ecoinvent database
Fertilizer (K)	kg	-	1.94	0.33	

Where SN1: Scenario 1; SN2: Scenario 2; SN3; Scenario 3

Waste Transportation

The estimated distance per ton of the study area that is required as input to the Umberto software for the life cycle analysis is based on the estimated 54 trucks each of 7.5 tons transporting the

wastes each of 5.0 tons at a round trip distance of 6.5 km daily. The transport truck “Transport, freight, lorry, 3.5 to 7.5, a metric ton (Rest of World)” was selected from theecoinventv3 database of the Umberto LCA software.

Recycling

The recycling of the recyclables materials is expected to occur at the existing sanitary landfill. In recycling activities, the manual sorting of waste was considered instead of the material recovering facility due to the presence of the registered waste pickers in a study area. The philosophy of the "cut-off" system model was also applied, suggesting that the burdens of recycling activity are allocated to the consumers of the recycled scraps. Therefore, their emissions were not included in the life Cycle Impact Assessment (LCIA) analysis (Pires *et al.*, 2011).

Composting

In this study, it is assumed that windrow composting will be employed. The decomposition of the organic matter and diesel requirements by the turning machines during composting process contributes to the greenhouse gas emissions. In most literature, typical diesel requirements in windrow composting by turning equipment is estimated at 0.47 litre per metric ton of waste (Sharma & Chandel, 2017). The total amount of carbon and nitrogen present in a metric ton of the compostable wastes was estimated from municipal solid wastes compositions of the study area (Table 8). The total amount of carbon and nitrogen present in a wet metric ton of wastes (67% organic wastes) were calculated as 151.41 kg-C and 6.52 kg-N per wet mass, respectively. Literature suggests that about 50% of each carbon and nitrogen are degraded for the production of mature compost (Boldrin *et al.*, 2009). So the same assumptions were made in the calculations. The methane (CH₄) emissions were computed as 1.1% of the fraction degraded carbon during the composting process (Amlinger *et al.*, 2008).

The ammonia emissions were also computed as 19.5% of the total nitrogen presents in a compostable waste (Haaren *et al.*, 2010). Other emissions were obtained from the literature. Umberto LCA+ software and Eco invent v3.6 database were used to supply the indirect emissions of the diesel consumption by equipment during the composting process. The ReCiPe

2008 Midpoint (H). V1.13 methodology was applied to obtain their emissions. Since the biowaste of the study area comprises of 55% Food wastes and 45% garden wastes, which are similar to compositions of waste as per (Boldrin *et al.*, 2009), the estimates of the average value of 0.34 kg-N, 0.40 kg P and 1.94 kg-K of inorganic fertilizers are assumed to be recovered per one metric ton of MSW during the composting process. The recovered nutrients are assumed to bring the benefit of avoided production of the fertilizers. The leachates produced during the composting process are assumed to be recycled back in the process, and therefore emissions in water were not considered.

Table 8: Moisture and major elemental composition (%) of the typical wastes in a study area

Moisture	C	H	O	N	S	Cl	P
59.79	56.20	5.42	35.49	2.42	0.31	0.05	0.11

Anaerobic Digestion

When organic matter is degraded under anaerobic digestion (AD), it releases methane and carbon dioxide in larger per cent, including the lower percentages of hydrogen, hydrogen sulphide, ammonia and siloxanes, aromatic and halogenated compounds (Rasi *et al.*, 2007). The modified Buswell Equation (Odedina *et al.*, 2017) was applied to quantify emissions in the AD process:

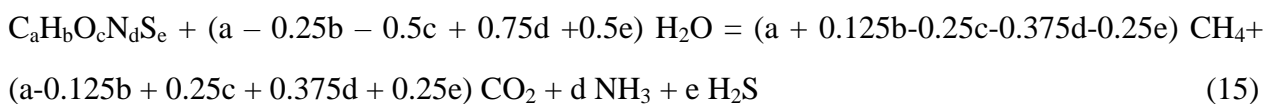

The typical elemental composition of the Arusha MSW is shown in Table 8, and the molecular equation was calculated by dividing the elemental compositions and atomic weights of the elements. Hence, for one metric ton of the waste to be digested, the biodegradable waste would be about 670 kg (67%). It contained C: 376.54 kg, H: 36.31 kg, O: 237.78 kg, N: 16.21 kg, and S: 2.08 kg and the molecular equation for emission were obtained as:

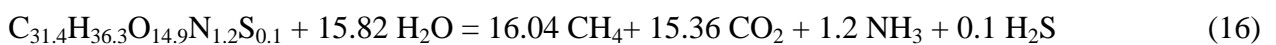

From the molecular equation and the computation, about 257 kg CH₄ and 676 kg CO₂ were

obtained. Since complete digestion depends on many factors, complete digestion may not be achieved; the proportionality factor of 0.7 was used to adjust the value. Hence, about (179.9 CH₄ kg and 473 kg CO₂) are obtained. It was assumed that 5% (8.995 kg) of methane is not captured for electricity generation and contributes to the environment's emissions (Belboom *et al.*, 2013). Kaza and Bhada-Tata (2018) indicated a potential electrical recovery per ton of MSW in AD to be in the range of 165 to 245 kWh, respectively. In this study, an average value of 205 kWh and an electricity consumption of 4.4 kWh per metric ton of MSW were used in the calculations. With the current under-construction of Rufiji hydroelectric power in Tanzania, which has a capacity of 2115 MW, the main source of energy in Tanzania considered in the analysis is hydroelectric power (World Heritage Watch, 2019).

Electricity consumption in the AD process is due to refining the waste ready for the AD process. From Ecoinvent database of Umberto software used, the application of the digestate for fertilizer use provides the nutrients of; N: 0.629%, P₂O₅: 0.331% and K₂O per kg of fresh digestate. Therefore, with the assumption that processing one metric ton of organic matter in the AD process generates about 100 kg of digestate (Khandelwal *et al.*, 2019), about 0.42 kg-N, 0.22 kg P and 0.33 kg-K are assumed to be recovered per one metric ton of MSW during the AD process.

Landfill

Emissions in a landfill can be attributed to the degradation of the organic matter and diesel requirements by vehicles used in the compaction of the wastes. To quantify the amounts of methane and carbon dioxide (Kumar & Sharma, 2017), the generalized Equation bellow was used:

$$\text{CH}_4 \text{ emissions (kg/tonne of MSW)} = \text{MSW}_L * \text{MCF} * \text{DOC} * \text{DOC}_F * F * (16/12 - R) * (1 - \text{OX}).17$$

The MSW_L is the wet weight of the municipal solid wastes disposed at the landfill; the MCF refers to the methane correction factor and ranges between 0.4 and 1 for unmanaged and managed well landfills (Lee *et al.*, 2017). The average value of 0.7 was selected because the landfills may not be perfectly managed in most developing countries. The DOC is the percentage of the degradable organic carbon in wet waste, and DOC_F is the fraction of the degradable carbon that converts to landfill gas (LFG) through waste decomposition.

In Arusha City, the landfilled waste comprises of food waste 37%, garden and wood 30%, and papers 11% (Landfilled 5.5%). By considering the typical composition of each organic wastes to be landfilled and estimated DOC_F for waste component (Food waste = 0.64, wood waste = 0.21 and papers = 0.37) as measured by the BMP test (Lee *et al.*, 2017), the DOC_F of the waste composition in a study area was estimated at 0.41. The value 16/12 is the carbon content of methane, F refers to the methane concentration in landfill gas, R is the recovered methane, and OX is methane oxidation factor and was estimated as F = 50%, R = 50%, OX = 36%) (Chanton *et al.*, 2009). From the computation, about 55 kg CH_4 are estimated as emissions to the environment.

During the compaction process of the wastes in a landfill, about 3 litres of diesel fuel per metric ton of MSW are utilized (Babu *et al.*, 2014). To process one metric ton of MSW in a landfill, electricity consumption of 0.42 kWh per metric ton of MSW would be required. Potential electrical recovery is estimated at 65 kWh per metric ton of MSW (Hong *et al.*, 2010; Kaza & Bhada-Tata, 2018). Inventory data and their associated emissions due to recyclable materials such as scrap metals, glass, plastic wastes that are landfilled were obtained from Eco invent v3.6 database embedded in Umberto LCA software. As the study used the exact percentages of 18.8% of the recyclables materials that are landfilled in all scenario, the impacts of their emissions are the same in all scenarios.

(iii) Life Cycle Impact Assessment

The LCA methods (The ReCiPe 2008 Midpoint (H). V1.13) and Umberto LCA+ software was used to evaluate the impact categories. The impact categories selected were climate changes, photochemical oxidant formation, freshwater eutrophication, terrestrial acidification, freshwater ecotoxicity, terrestrial ecotoxicity, human toxicity and particulate matter formation. These impact categories were selected because the groundwater and surface water are the main sources of water in Arusha City and therefore, emissions from the proposed MSW treatment might be detrimental to water sources, land and air.

(iv) Sensitivity Analysis

The sensitivity analysis focused on assessing whether improvement on the process which mostly contributed to impact categories would result in an improvement on impact categories. This was achieved through assuming an increase of 5% improvement on different process and recovery of the resources in scenarios, and then the variability (in terms of range) upon improvement was determined. Another sensitivity analysis performed aimed at evaluating the reliability of the ReCiPe 2008 Midpoint (H). V1.13 LCIA results obtained. This was achieved by comparing the LCIA results obtained from ReCiPe 2008 Midpoint (H). V1.13 with the results obtained from IPCC 2013 and ILCD 2.0 2018 LCIA methodologies.

3.5 To assess Economic Feasibility of the Biogas Plant for Municipal Solid Waste Management in Arusha City of Tanzania

In this section, the economic feasibility of the biogas plant for MSW in Arusha City, Tanzania, was investigated. The estimates of the digester capacity, investment costs, operation and maintenance costs and revenues are analyzed based on the quantity of the wastes generated. Two types of waste, pre-treated banana leaves waste and food wastes supplemented with edible clay soils, were considered in the analysis. Then economic viability of the project was assessed using the net present values, and payback period techniques.

3.5.1 Estimation of the Investment Costs

The anaerobic digester's investment and operation cost vary depending on the type of

construction materials, labour costs, local climate, type of feedstock to be treated and so on. The investment cost is estimated based on the capital cost and includes the biodigester, generator and other auxiliary equipment, including shredder and power shovels. On the other hand, the operation costs included; the costs for the labours work, water, repair and maintenance work. Whereas the capital cost of the digester can be estimated based on the size of the digester, the capital cost of the generator can be calculated based on the electricity generation. By Naami (2017), the cost of the digester is estimated to be US\$118 per m³, the cost of the generator is estimated to be US\$ 320 per kW installed. For the medium and large biogas plant, the auxiliary equipment including shredders, and shovel, are also included in the analysis. The shredder will be used for processing the OFMSW into smaller particles for enhancing the AD process. The shovel will be used for the excavation works and loading of the wastes, and removing the wastes into the biodigester. The costs of shredders and power shovels were estimated at US\$ 2/ton and US\$ 1.5/ton, respectively (Patinvoh *et al.*, 2017). The project period considered in the analysis is 20 years.

3.5.2 Estimations of Operation and Maintenance Costs

The following assumptions are given on estimating operation and maintenance costs; the land purchase cost is not included and is assumed to be provided by the Arusha City council. Currently, the collection costs are covered by the collection fees, and therefore their analysis is also not included in the calculation. The plant equipment's annual repair and maintenance cost is estimated as 5% of the initial capital investments. The estimated costs for; sorting out waste fractions, water to be mixed in the biodigesters, plant operators, lab technicians and post-treatments of the digestate after the process was also made.

3.5.3 Estimations of the Revenues

The biogas and fertilizers from banana leaves and food wastes (objective ii and iii) were used to calculate the revenues from the Arusha biogas plants.

3.5.4 Economic Analysis of the Biogas Plants

The net present value and payback period methodologies have been used to assess the economic

viability of this project. Project life is considered to be 20 years at a discount rate of 10%. The Net Present Value (NPV) is the sum of discounted cash flows (inflows and outflows) that considers the time value of money in evaluating capital investments. Projects are deemed to be profitable if the NPV are greater than zero. The higher the NPV, the more economic benefits the project indicates. The Net Present Value was computed using Equation 18:

$$NPV = \sum_{y=0}^N \left(\frac{Ry - OPCy}{(1+r)^y} \right) - CAC \quad (18)$$

The NPV is the net present value of the power plant, Ry is sales Revenues in yth Year, OPCy is Operating Costs in yth Year, CAC is initial investment costs of the power plant, N is project life period r is the discount rate. The Payback Period (PB) measures how long the capital investments are recovered through the annual cash inflows. The shorter payback period indicates a better investment. The PB was computed as per Equation 19:

$$PB = n + \left(\frac{CAC - CFP}{CFR} \right) \quad (19)$$

Where n is the immediately previous period in which the investment is recovered, CAC is the initial investment costs of the power plant, CFP is the accumulated Cash Flow from the immediately Previous years in which the investment costs are recovered, and CFR is the cash flow for the period in which the investment cost is recovered.

CHAPTER FOUR

RESULTS AND DISCUSSION

4.1 Effects of Fungal (*Pleurotus ostreatus*) treatment on Banana Leaves Wastes towards Edible Mushrooms and Biogas Recovery

4.1.1 Characterization of the Banana Leaves Wastes

Table 9 depicts banana leaves characteristics before fungal pre-treatment. The TS and VS (% TS) contents were 24.5 and 84.3%, respectively, indicating that banana leaves are suitable for fungal treatment. The C/N and pH of the BL were within acceptable ranges for FP, as reported by some authors. Bellettini *et al.* (2016) reported that the substrates with the C/N ratio range between 15:1 and 25:1 and pH range between 6.5 and 7.0 are well suited for FP. The moisture content was adjusted to 75% for the most effective results with *P. ostreatus* as indicated in literature (Mustafa *et al.*, 2016; Zakil *et al.*, 2019). The lignocellulosic components: Cellulose, hemicellulose, and lignin, were also similar to the reported values for un-pre-treated banana leaves as reported by some authors.

Fernandes *et al.* (2013) reported the cellulose, hemicellulose and lignin for semi-dried banana leaves to be 26.7%, 25.8% and 17%, respectively. In comparison with the biomass compositions of other substrates such as rice straw, beach wood, and palm midrib pre-treated with *P. ostreatus*, it seems hemicellulose and lignin contents which are mostly affected by *P. ostreatus* ranged from 11.2% to 22.9% and 13.1% to 22.9%, respectively (Bari *et al.* 2015; Metri *et al.* 2018; Mustafa *et al.* 2016; Owaid *et al.* 2017). Therefore, the biomass compositions of the banana leave analyzed in this study fall within acceptable limits for the fungal treatment. The pH in the anaerobic digestion process for untreated and treated BL were 7.90 ± 0.02 , and 7.40 ± 0.00 , respectively, and were within acceptable ranges for the AD process (Widyarani *et al.*, 2018). According to Vögeli *et al.* (2014), substrates with more than 60% VS are suitable for resources recovery such as biogas production. In the current study, the VS for untreated and treated BL were 84.3 and 75.7%, respectively - these were above 60% and therefore, acceptable for biogas production.

Table 9: Characteristics of banana leaves before and after fungal treatment (Mean \pm SD)

Component (%)	Untreated		% Decrease after Pre-treatment
	Banana Leave Waste	Fungal Pre-treated	
pH	8.2 \pm 0.1	6.4 \pm 0.1	-
Volatile Solids (%TS)	84.3 \pm 0.5	75.7 \pm 0.8	10
Cellulose	28.9 \pm 0.9	26.9 \pm 0.7	7
Hemicelluloses	23.5 \pm 1.1	17.9 \pm 0.7	24
Lignin	18.9 \pm 0.5	16.9 \pm 0.6	10
C/N ratio	18.8 \pm 0.3	-	-

4.1.2 Fungal Treatment (*Pleurotus ostreatus*) of Banana Leaves Wastes

Table 10 indicates the number of days taken for spawn running, pinhead formation, and the formation of fruiting bodies, number of clusters, yields and biological efficiency for ten mushroom bags used in the experiment. The spawn running took about 29 days, followed by an average of 3 days of pinhead formation. The complete fruit body formation and the mushroom harvest took about 36 days. The average weight of the mushroom harvested per 2 kg of BL bag was 181 \pm 19 g, which was slightly lower than those reported by other authors (Amirta *et al.*, 2016). The percentage of Biological Efficiency (BE) in this study was 37%. When cultivated in different substrates, the varying biological efficiency results with *Pleurotus ostreatus* have been reported in the literature. Yang *et al.* (2013) indicated that the BE with *Pleurotus ostreatus* when cultivated with sterilized rice and wheat straws supplemented with wheat bran (20%) were found to be 53.9 and 51.3%, respectively.

Vieira and de Andrade (2016) studied the effect of the cultivation of oyster mushroom (*Pleurotus ostreatus*) on different potential materials: decumbens grass, brizantha grass, sugarcane bagasse and wheat straw with nitrogen supplementation. The results indicated that BE increased with nitrogen supplementation with BE ranging from 86.4% (wheat straw) to 123.9% (brizantha grass). In comparison to these findings, the low BE value obtained in this study is attributed to many factors, including the treatment's purpose. After the treatment, the materials were subjected to an anaerobic digestion process. Therefore, the treatment was conducted without supplementation

with other substrates or materials to maximize BE for mushrooms productions. In other studies in which the BE was high, the purpose was to maximize BE for mushrooms production. However, the results obtained in this study was slightly higher than the results obtained by Girmay *et al.* (2016), who indicated the BE of *Pleurotus ostreatus* when cultivated in paper waste and wheat straw to be 34.2% and 35.9%, respectively. Therefore, the difference in BE results with *Pleurotus ostreatus* is attributed to many factors, including the spawn rate used, strain type, number of times the mushrooms were harvested, and optimization conditions to mention a few.

Table 9 presents the results of the compositions of dry BL after fungal treatment. After the fungal treatment, the VS of banana leaves was 75.7%, indicating the loss of about 10% VS from non-treated BL. The decreased VS means that part of the organic matter of the pretreated substrates was incorporated into fruiting body formation. The pH of the BL approximately reduced by two units after the fungal treatment. Rouches *et al.* (2016) indicated that the pH drop during fungal treatment is probably caused by the release of acetyl groups during the delignification process. The biomass compositions, cellulose (CE), hemicelluloses (HCE) and lignin (LIG), decreased by 7%, 24% and 10%, respectively, after the fungal treatment. This result suggests that hemicellulose and lignin were more degraded by *P. ostreatus* as compared to cellulose. Previous studies indicated that *P. ostreatus* is more selective to lignin and hemicellulose degradation than cellulose (Bari *et al.*, 2015; Metri *et al.*, 2018; Owaid *et al.*, 2017). The reduced lignin concentration means that cellulose is easily exposed to fermentative microorganisms activities during biogas recovery (Budzianowski, 2016). In addition to the loss of the organic matter, Table 11 indicates that the trace elements (Fe, Mn, Co, Ni and Mo) in un-treated banana leaves was significantly higher than the treated banana leaves ($P < 0.05$) as tested by T-test in regression analysis of Ms excel. The reduced trace elements in treated banana leaves indicate that mushrooms bio cumulates the trace elements from the cultivated substrates.

Table 10: Mushroom formation, number of clusters, fruit bodies, yield and biological efficiency

Spawn Running (Day)	Pinhead Formation (day)	Mushroom Harvest (day)	Clusters (Nos)	Fruit Bodies (Nos)	Yield (g of fresh Mushroom/2 kg of the Substrate)	Biological Efficiency (%)
29 ± 3	32 ± 3	36 ± 3	3 ± 1	32 ± 8	181 ± 19	37 ± 4

Results comprise of the mean of ten mushroom bags ± standard deviations



Table 11: Trace elements compositions in banana leaves before and after fungal treatment

Trace Elements	Before Treatment	After Treatment
Fe (%)	0.653 ± 0.005	0.399 ± 0.004
Mn (%)	0.054 ± 0.007	0.034 ± 0.004
Mo (ppm)	20.833 ± 6.714	17.967 ± 1.674
Co (ppm)	8.03 ± 0.058	6.50 ± 0.000
Ni (ppm)	1.67 ± 0.058	1.60 ± 0.000

Results comprise of the mean of three replicates ± standard deviation (Mushroom bio cumulates the trace elements from the cultivated banana leaves)

4.1.3 Anaerobic Digestion Process of Fungal Treated Banana Leaves Wastes

Figure 5 indicates the daily biogas yield for untreated and treated banana leaves. Both reactors showed the quick release of biogas after day one and gradually decreased before increasing again. Within the first two days, the biogas yield in a fungal treated BL was slightly higher than that in un-treated BL but dropped to zero in day 4 to day 19 before it started to increase again. The quick-release of biogas in a fungal treated BL may be attributed to reduced lignocelluloses components after fungal treatment with *Pleurotus ostreatus*. The peak daily biogas yield in fungal treated BL was 32.36 mL g⁻¹ VS⁻¹d⁻¹ which was observed on day 28. On the other hand, during day 40 of the experiment, the biogas yield in the un-treated BL was significantly higher (P < 0.05) compared to the biogas yield in fungal treated BL. The un-treated BL reactor showed a stable biogas production and a peak daily biogas yield of 71.26 mL g⁻¹ VS⁻¹d⁻¹ which was observed on day 9.

Figure 6 indicates the cumulative biogas yields for un-treated BL and fungal treated BL. After 40 days of the AD process, the cumulative biogas yield in the fungal treated BL was 282 mL g⁻¹ VS⁻¹ which was three times lower than that of the un-treated BL (863 mL g⁻¹ VS⁻¹). The lower biogas yield in a fungal treated BL was attributed to the reduced trace elements concentration and decreased VS during the fungal treatment process. The quick, stable biogas yield in an un-treated BL reactor during day 40 of the experiment may be attributed to the higher essential elements in un-treated banana leaves, as indicated in Table 11. The biogas production obtained by fungal treatment of banana leaves with *P. ostreatus* compared with other pre-treatment techniques of

banana leaves is discussed below.

The findings from Chanakya and Sreesha (2012) indicated that retting as a pre-treatment of banana leaves in a plug flow digester at the retention time of 30 d resulted in a biogas yield of 400 mL g⁻¹ TS⁻¹ at room temperature of 28 °C after 40 days of digestion. This biogas yield was considerably higher than the biogas yield of 282 mL g⁻¹ VS⁻¹ (corresponding to 214 mL g⁻¹ TS⁻¹) observed in our study. In another study, Jena *et al.* (2020) investigated the influence of FeCl₃ addition to improve the biogas production from semi-dried banana leaves. The addition of FeCl₃ resulted in the cumulative biogas production of 2105 mL (when the production by inoculum is subtracted), which was higher than the results obtained in the current study (743 mL). However, in another study by Kamdem *et al.* (2013), the biogas yield of 126 mL g⁻¹ TS⁻¹ was obtained from physical treatment through size reduction of banana leaves, which was lower than 214 mL g⁻¹ TS⁻¹ obtained in this study. As indicated in their research, the lower biogas yields were high lignin concentration in banana leaves, which affected the digestibility. In this study, the fungal treatment enhanced lignin degradation by 10%. Generally, this study shows that *Pleurotus ostreatus* can be cultivated on banana leaves waste to produce Oyster mushrooms. This creates a sustainable means to manage un-utilized banana leaves wastes.

The pH after the AD process was 7.18 and 7.3 for fungal treated and untreated BL, respectively, which was slightly alkaline and suitable for the methanogenic process (Zhao *et al.*, 2019). After 40 d of the AD process, the volatile solid removal efficiencies were 4.1% and 5.6% for fungal treated and un-treated BL, respectively. This suggests that the experiment would require more time for more organic matter removal the process. The total alkalinity increased after the AD process from 2247 mg CaCO₃/L to 4734 mg CaCO₃/L and 2189 mg CaCO₃/L to 4974 mg CaCO₃/L for un-treated and fungal treated BL, respectively. The increase of the total alkalinity is mainly attributed to the breakdown of protein and amino acids that generate ammonia. The ammonia generated help to contribute to the formation of NH₄ (HCO₃) buffer when combines with CO₂ and H₂O as per Equation (20), resulting in the process stability of the batch reactors (Shen *et al.*, 2016). The volatile fatty acid accumulation decreased after 40 days of the AD process from 2415 mg L⁻¹ to 613 mg L⁻¹ and 1440 mg L⁻¹ to 633 mg L⁻¹ for fungal treated and un-treated BL, respectively. These VFAs concentrations were still significantly high and indicated that organic matter's total conversion was not yet achieved. According to Maragkaki *et al.* (2018),

the negligible or absence of VFAs in digestates of the AD process indicates the total conversion of the organic matter to biogas. The VFA/Alkalinity ratio after the AD process were 0.12 and 0.13 for untreated and treated BL, respectively. The low VFA/Alkalinity ratios indicate that the methanogenic stage was stable and was not disturbed by VFAs in the AD process.

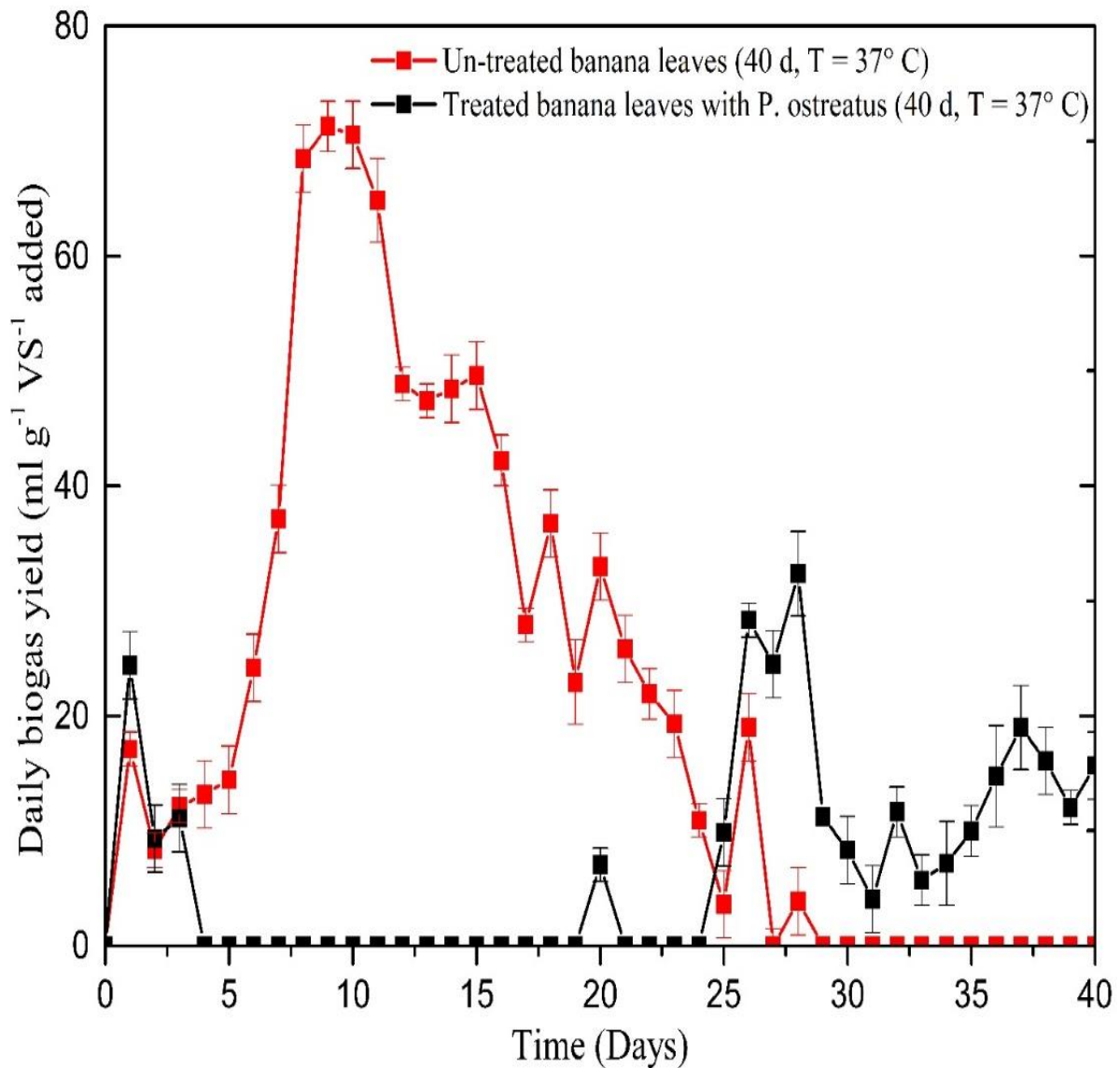

Figure 5: Daily biogas yields of un-treated and fungal treated banana leaves by *P. ostreatus*; data are means of the two replicates

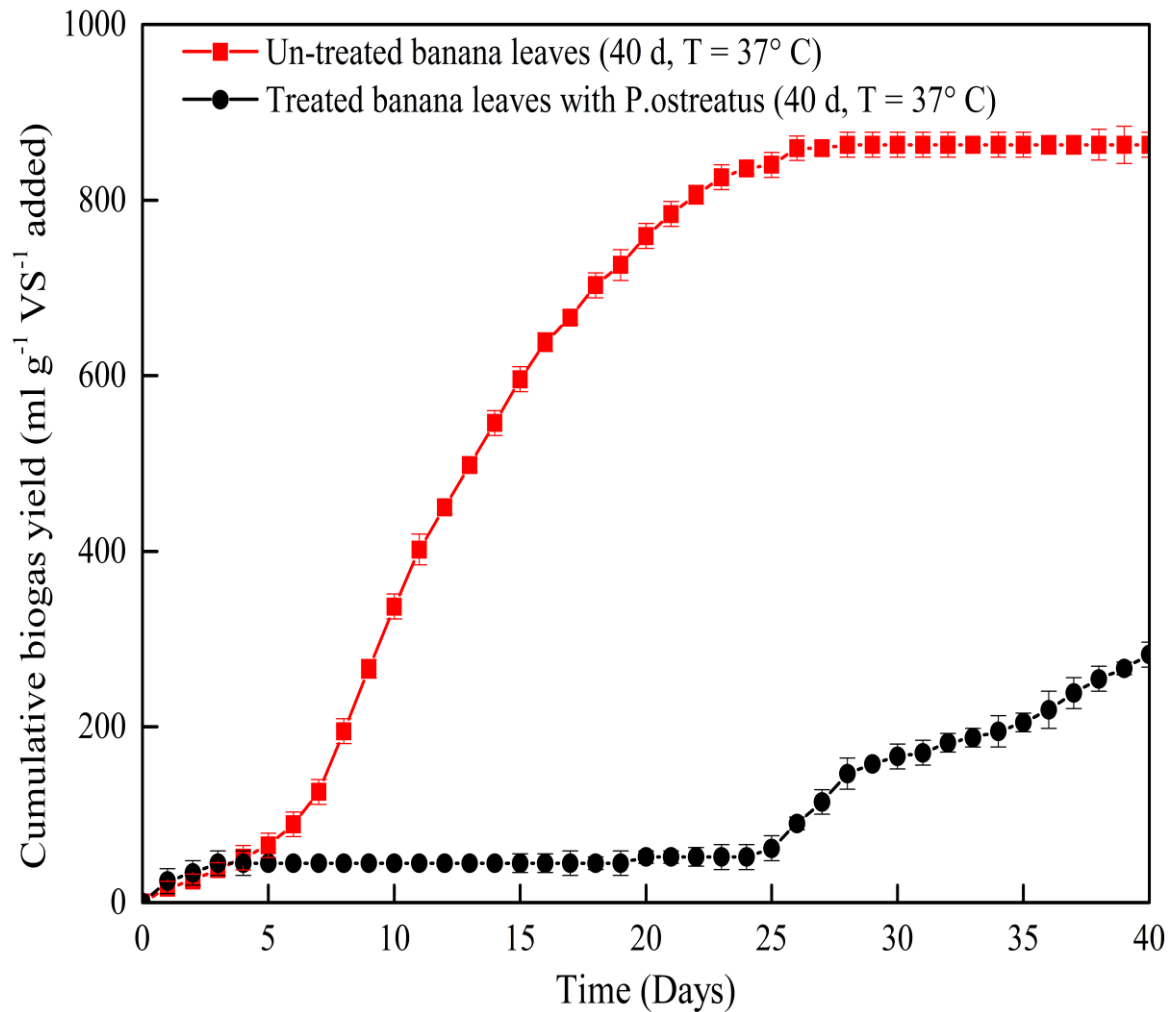

Figure 6: Cumulative biogas yields of un-treated and fungal treated banana leaves by *P. ostreatus*; data are means of the two replicates

4.1.4 Cost Analysis of Fungal (*Pleurotus ostreatus*) Treatment of Banana Leaves Wastes

Economic benefits of using fungal species *P. ostreatus* (oyster mushroom) for the treatment of BL include; income generation from sales of edible mushrooms and improved nutrition from minerals, nutrients and protein available in the mushrooms.

To evaluate the economic benefits of the fungal (*P. ostreatus*) on the BL, the capital and operating costs were estimated based on the data collected in this study. The costs of experimental materials based on market prices during the period of the study. The capital costs comprised constructing a fungal pre-treatment hut, pasteurization container, and other simple tools such as thermometers and spray bottles. Operating costs included sorting, collection and transportation of BL substrate, fuel costs, labour charges, fungal spawn cost, and depreciation cost of the capital investment. The

net profit after the fungal pre-treatment was determined based on the difference between the sales incomes of the mushroom produced and operating costs. The mushroom prices based on the supermarket's prices during the period of the study. Table 12 depicts the cost-benefit analysis of using this pre-treatment approach. The amount of investment per ton of BL is estimated at 282.19 US\$, and operation cost per ton is 173.80 US\$. An assessment of the operation cost reveals that expenditures on the spawn cost were the main components, accounting for 40% of the total operating costs. On average for one growing cycles of 1 ton of BL can result in 90.5 kg of fresh mushrooms generating about 196.39 US\$. The net profit after accounting for the operating cost is approximately only 22.59 US\$ per ton of the substrate. However, when the investment cost is considered, there is no benefit at the beginning and the payback time of the capital investment is 12.49 (capital cost/net profit), which is high. However, the net profit can be increased and payback time reduced if BL can be used several times for fungal treatment to produce edible mushrooms.

Table 12: Cost analysis of the fungal -treatment on banana leaves

Items	Activities and Equipment	Amount (US\$)
Capital Cost (CC)	Construction of treatment hut (coconut leaves roofs, tree barks wall)	217.07
	Pasteurization container	21.71
	Other tools (Sprayers, thermometer, spoons, plates)	43.41
	CC Subtotal	282.19
Operating cost for one growing cycle (OC)	Sorting, collection and transport of substrates	21.71
	Polythene bags	17.37
	Fire woods	10.85
	Cost of spawn bottle, 0.87 US\$ per bottle (80 Nos)	69.60
	Labor	21.71
	Water for pasteurization and regulating humidity	4.34
	OC subtotal	145.58
	Depreciation (Non-Recurring Expenditure (CC)) @ 10%	28.22
	Total operating cost (TOC) for one ton	173.80
Sales Income (SI)	1 ton of wastes for one growing cycle can produce about 90.5 kg of edible mushrooms, of which each kg is approximately about 2.17 US\$	196.39
	SI subtotal	196.39
Net Profit	SI subtotal-TOC subtotal	22.59
The payback time of capital investment	CC cost/Net profit	12.49

In AD experiments, when the biogas production by inoculum is subtracted, about 743 and 1850 ml of biogas were collected from 20 g of the fungal-treated and un-treated BL. Then 1 ton of the fungal-treated and un-treated BL would produce about 37.5 m³ and 92.5 m³ of biogas, respectively. According to Vögeli *et al.* (2014), each 1 m³ of biogas contains approximately 6- 6.5 kWh of calorific energy depending on the composition of the biogas when converted into electricity. The gas generator converts about 35% of the biogas into useable electricity (Vögeli *et al.*, 2014). Then based on this information, electricity in kWh from biogas production from fungal-treated and un-treated BL can be estimated as; 78.75 kWh (0.35 x 37.5 m³/ton x 6 kWh) and 194.25 kWh (0.35 x 92.5 m³/ton x 6 kWh), respectively. The current cost of purchasing electricity in Tanzania is about US\$ 0.154 per unit kWh; therefore, about US\$ 12.13 and 29.91 US\$ per ton of fungal-treated and un-treated BL would be generated. When accounting for the net profit of US\$ 22.59 from the sales of edible mushrooms, 1 ton of fungal treated BL would therefore generate about US\$ 34.72. Therefore, despite the lower biogas yield of the fungal treated BL in comparison to the non-treated BL, mushroom cultivation followed by AD is economically favored.

4.2 Effectiveness of Banana Winery Wastewater in Digesting the Banana Leaves Wastes to Improve Methane Yield

4.2.1 Feedstock Characteristics

Table 13 and Fig. 7 depict the average characteristics of bottle-washing water from the banana winery industry used for the pre-treatment of BL. For COD, TS and VS measurements, the samples were collected four times at four different weeks in August. For the pH measurements, the samples were collected fifteen times on different days of August. The COD in the bottle-washing water during the measured period ranged from 2304 to 2770 mg/L. The TS and VS values ranged from 2.13 to 2.25 g/kg and from 0.39 to 0.52 g/kg, respectively. The bottle-washing water from the banana winery industry had the pH value range between 11.7 and 12.2 for the fifteen measurements conducted in August 2020. The high pH in bottle-washing water from the banana winery industry is due to caustic soda (NaOH) application to clean banana wines bottles. The untreated BL characteristics are summarized in Table 14. Banana leaves have relative high macronutrients; calcium (Ca), Sodium (Na), magnesium (Mg), and potassium (K)

ranged from 1803 to 26 480 mg/kg as compared to trace elements. The macronutrients are beneficial for enhancing metabolic activities in the anaerobic digestion process (Zhang *et al.*, 2011). The metals cations (Na, K, Ca and Mg) can combine with organic acids such as acetic acids formed during the acidification stage of the anaerobic digestion process. During anaerobic digestion, the combined cations and organic acids can decompose to generate $\text{HCO}_3^- / \text{CO}_3^{2-}$ buffer (Equation 21) (Shen *et al.*, 2016). The trace elements (Iron, Cobalt, Nickel, Molybdenum, Selenium, Manganese, zinc) in BL ranged from 0.53 to 6525 mg/ kg, which were relatively lower than macronutrients (except Iron which was higher than Na and Mg). The trace elements are essential for improving volatile fatty acids consumptions, process stability and methane yields (Banks *et al.*, 2012). Table 15 depicts substrates characteristics for the anaerobic digestion process in three batch reactors; R1: Pre-treated BL with inoculum, R2: Un-pre-treated BL with inoculum and R3: Inoculum. The pH for the feedstock in reactors; R1, R2 and R2 were 7.3, 7.44 and 7.48, respectively, which were within recommended ranges of 6.5–7.5 for enhancing microorganisms' activities for biogas generation. Vögeli *et al.* (2014) suggest the substrates with more than 60% VS (%TS) to be suitable for biogas recovery. The substrates VS in reactors R1, R2 and R3 were more than 80% (%TS), indicating that more digestible organic matters for the AD process were contained in substrates. The carbon to nitrogen (C/N) ratios were 19.34 for the R1 and R2, respectively, which were within the acceptable ranges of the AD process as reported in the literature. Wu *et al.* (2010) indicated that substrates with a C/N ratio range of 16 – 25 are suitable for the AD process.



Table 13: Banana wine bottle-washing water characteristics

Parameter	Unit	1 st	2 nd	3 rd	4 th
		Measurement	Measurement	Measurement	Measurement
COD	mg /L	2620	2770	2560	2304
Total solids (TS)	g/kg	2.19	2.25	2.18	2.13
Volatile solids (VS)	g/kg	0.44	0.52	0.43	0.39
VS/TS	-	0.20	0.23	0.20	0.18

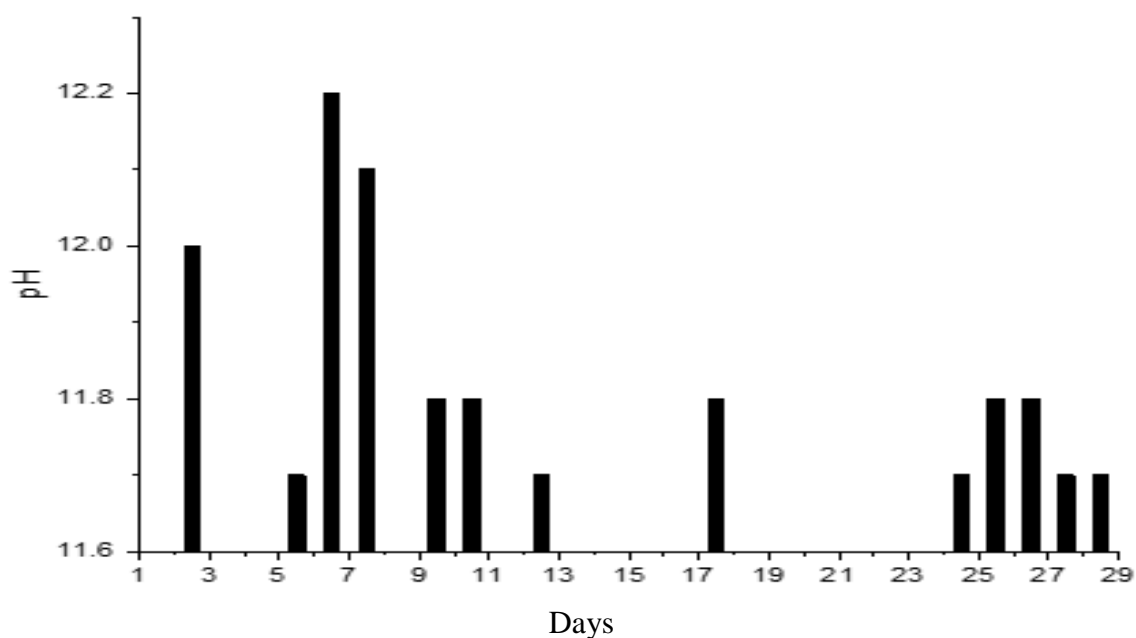

Figure 7: pH values of the bottle-washing water

Table 14: Metal elements in banana leaves (Mean \pm standard deviations of three replicates)

Trace elements	Value in mg/kg	Macronutrients	Value in mg/kg
Iron (Fe)	6,525 \pm 49.2	Sodium (Na)	1803 \pm 40.4
Zinc (Zn)	33.03 \pm 2.8	Potassium (K)	22 730 \pm 100
Cobalt (Co)	8.03 \pm 0.06	Calcium (Ca)	26 480 \pm 173.5
Molybdenum (Mo)	27.5 \pm 18.21	Magnesium (Mg)	3511 \pm 7.5
Nickel (Ni)	1.67 \pm 0.06		
Selenium (Se)	0.53 \pm 0.06		
Manganese (Mn)	538.1 \pm 70.9		

Table 15: Characteristics of substrates used in the anaerobic digestion process

Parameters	R1 (Pre-treated BL)	R2 (Un-pre-treated BL)	R3 (Inoculum)
pH	7.3	7.44	7.48
TS (%)	8.09 \pm 0.21	8.45 \pm 0.04	5.0 \pm 0.06
VS (%)	6.71	7.01	4.12
VS (% TS)	82.94 \pm 0.1	82.93 \pm 0.04	82.51 \pm 0.03
Alkalinity (mg/L)	1013.35	1268.56	805.68
VFA (mg/L)	662.23	1185.02	622.48
VFA/Alkalinity	0.654	0.934	0.773
Carbon /Nitrogen (C/N)	19.34	19.34	-

BL: Banana leaves

4.2.2 Effect of the Pre-treatment on Lignocellulosic Components

Based on Table 16, the composition of BL before pre-treatment with bottle-washing water from the banana winery industry contained 19.79% of lignin, 28.71% of cellulose and 26.24% of the hemicellulose. These values of compositions biomass were similar to the reported values for un-pre-treated BL by the other researchers (Fernandes *et al.*, 2013; Jena *et al.*, 2017). The relative lower lignin contents of BL makes BL suitable for alkali pre-treatment because alkali is ideal for the pre-treatment of low lignin contents biomass (Agbor *et al.*, 2011). After pre-treatment of BL through soaking for 48 h, the cellulose increased by 4.35%, and hemicellulose decreased by

6.74%, and lignin content decreased by 3.94%.

The reduced lignin content is beneficial for the recovery of the biogas as more cellulose and hemicellulose are exposed to the microorganisms during the anaerobic digestion process. This result suggests that hemicellulose was more decomposed by NaOH in BW than cellulose and lignin. Zhang *et al.* (2013) indicated that NaOH is more reactive to hemicellulose during the pre-treatment than cellulose and lignin contents. The changes in biomass compositions in this study following pre-treatment with BW from banana wine is similar to previous studies regarding NaOH pre-treatment in various lignocellulosic biomass.

You *et al.* (2018) studied the combined effect of NaOH and CaO pre-treatment on corn stover. The pre-treatment resulted in lignin removal efficiency and ranged from 24.8% to 44.6%, with the best results obtained when the amount of CaO in pre-treatment increased. Similarly, Zheng *et al.* (2010) investigated the effect of pre-treatment of corn stover with NaOH at varying treatment time, temperature and moistures. The results indicated that the lignin removal efficiency ranged from 3.9% (2% NaOH, Time = 3 d, Temperature = 10 °C) to 26.9% (2% NaOH, Time = 3 d, Temperature = 50 °C). Therefore, it can be seen that the results for lignocellulosic biomass composition changes depended on NaOH concentration and some conditions applied in the pre-treatment. The relative lower lignin removal in this study is attributed to the lower NaOH concentration in BW (estimated at 0.03% from computation and confirmed in the laboratory by dissolving 300 mg in a litre of distilled water).

Table 16: biomass compositions changes of banana leaves before and after pre-treatment

Biomass Compositions (%)	Un pre-treated Banana Leaves	Pre-treated Banana Leaves
Cellulose	28.71 ± 1.26	29.96 ± 2.35
Hemicellulose	26.24 ± 1.05	24.47 ± 1.99
Lignin	19.79 ± 0.69	19.01 ± 0.99

4.2.3 Effect of the Pre-treatment on Biogas Productions

Figure 8 and 9 indicate that pre-treatment of BL with bottle-washing water from banana wines have significantly improved the biogas yield in the AD process of BL. Both reactors contained pre-treated, and unpretreated BL began to release biogas yield of more than $4 \text{ mL g}^{-1} \text{ VS}^{-1}$ added on day 1. The biogas yield in the reactor contained pre-treated BL kept increasing to $11.7 \text{ mL g}^{-1} \text{ VS}^{-1}$ on the second day and gradually declined to $0.69 \text{ mL g}^{-1} \text{ VS}^{-1}$ on day 5. From day 6, the biogas yield kept increasing to $30.44 \text{ mL g}^{-1} \text{ VS}^{-1}$ on day 11, before decreasing progressively again to $1.383 \text{ mL g}^{-1} \text{ VS}^{-1}$ on day 22. The highest daily peak in the reactor contained pre-treated BL was $39.4 \text{ mL g}^{-1} \text{ VS}^{-1}$ and was observed on day 22 of the experiment. From day 49 until the experiment was stopped on day 60, a lower biogas yield of $1.38 \text{ mL g}^{-1} \text{ VS}^{-1}$ was observed in a reactor containing pre-treated BL. On the other hand, the biogas yield in a reactor contained un-pre-treated BL decreased to zero on day 4 until day 11, when it started to increase again until it attained the daily peak of $17.8 \text{ mL g}^{-1} \text{ VS}^{-1}$ on day 36.

The cumulative biogas yield in the reactor with pre-treated BL was $583 \text{ mL g}^{-1} \text{ VS}^{-1}$ which was 4.3 times higher than that of the reactor with un-pre-treated BL ($135 \text{ mL g}^{-1} \text{ VS}^{-1}$). The increase in biogas yield in the reactor with the pre-treated BL is attributed to the increased accessibility of cellulose and hemicellulose by microorganisms in the AD process as consequences of reduced lignin concentrations. Some previous results support these findings that alkaline pretreatment of lignocellulosic substrates with NaOH would improve biogas production. According to Zhang *et al.* (2015), the pre-treatment of the rice straw with extrusion combined with NaOH increased methane production by 54% than that of rice straw without the pre-treatment. Zhang *et al.* (2013) reported an increase in biogas and methane yields by 12.1 and 21.4%, respectively, in the banana stem pre-treated with 6% NaOH compared to the control sample of un-pre-treated banana stem. Similarly, Sambusiti *et al.* (2013) indicated that pre-treatment of wheat straw with 10% NaOH at $40 \text{ }^{\circ}\text{C}$ and $100 \text{ }^{\circ}\text{C}$ enhanced the methane yields by 48% and 67% compared with un-treated wheat straw.

Similarly, Figure 11 and 12 show that the cumulative methane yield in a reactor containing pre-treated BL was $231 \text{ CH}_4 \text{ mL g}^{-1} \text{ VS}^{-1}$ which was 5 times higher than the methane yield obtained in the reactor un-pre-treated BL which had only $46 \text{ CH}_4 \text{ mL g}^{-1} \text{ VS}^{-1}$. The high methane

content of 64.3% was obtained on day 26 in the reactor with pre-treated BL. High methane content of 43.4% was observed in a reactor with un-pre-treated BL on day 41. The degradation performance of the AD process was measured in terms of VS degradation. The VS has been reported to play a significant role in the transportation of the sludge, and thus its reduction is essential in reducing the transportation costs (Hallaji *et al.*, 2019). Before the anaerobic digestion process, VS in the pre-treated and un-pre-treated BL was 6.71% and 7.01%, respectively. It can be seen after 60 days of the AD experiment, the VS in the pre-treated and un-pretreated BL decreased by 32.9% and 20.8%, respectively. The higher VS degradation in the pre-treated BL compared to the un-pre-treated BL implied that microorganisms utilized more organic contents in a reactor with a pre-treated BL to produce biogas. These results indicate that increased biogas production is proportional to VS reduction.

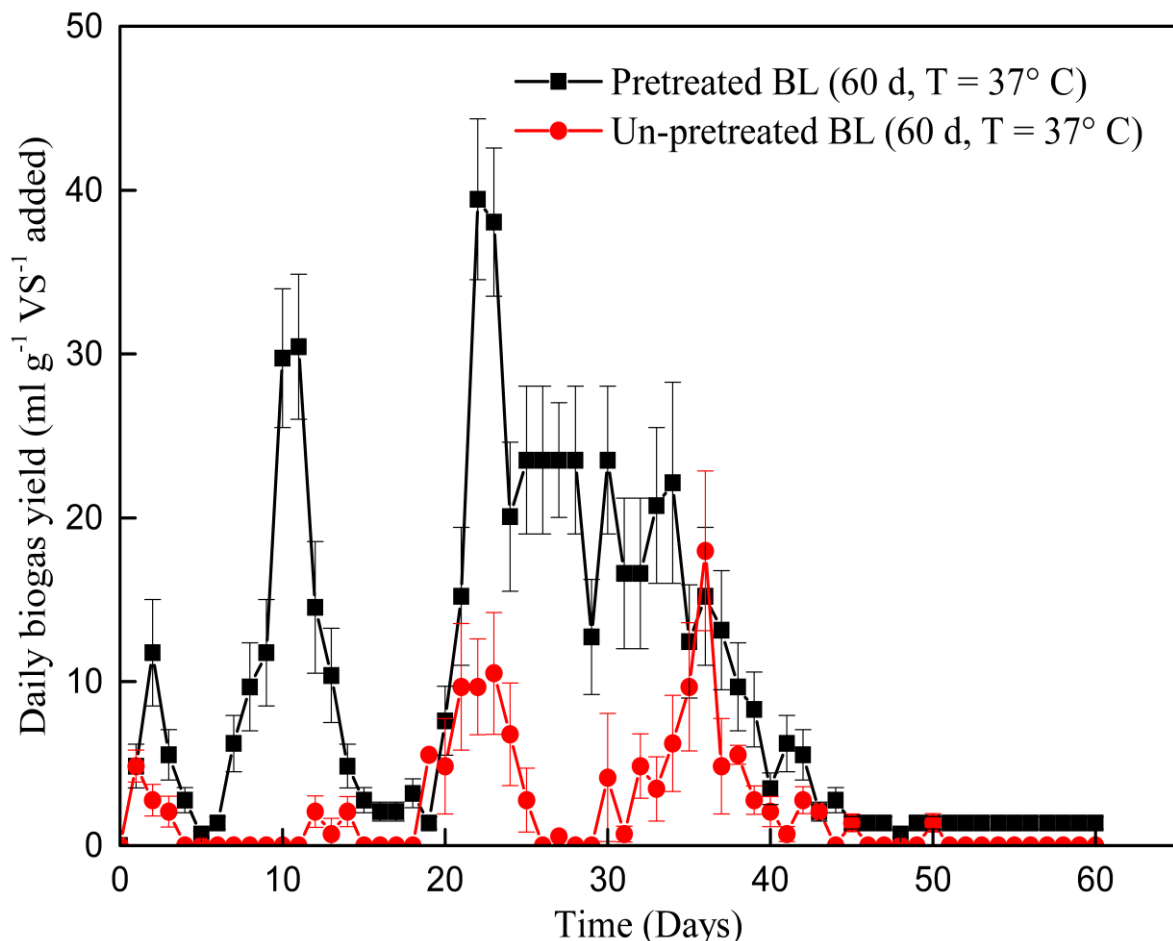

Figure 8: Daily biogas yields of pre-treated and un-pretreated banana leaves

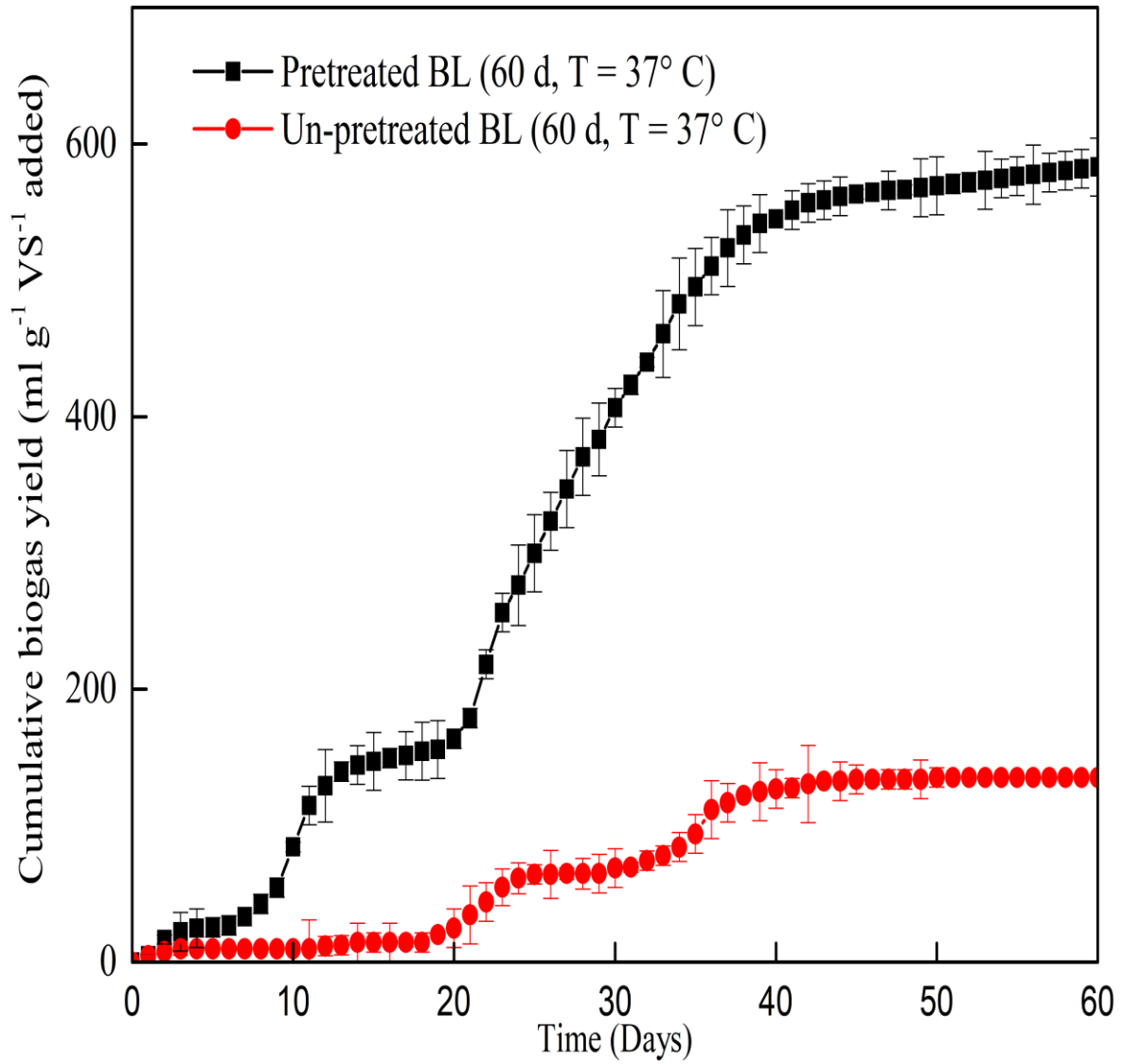

Figure 9: Cumulative biogas yields of pre-treated and un-pretreated banana leaves

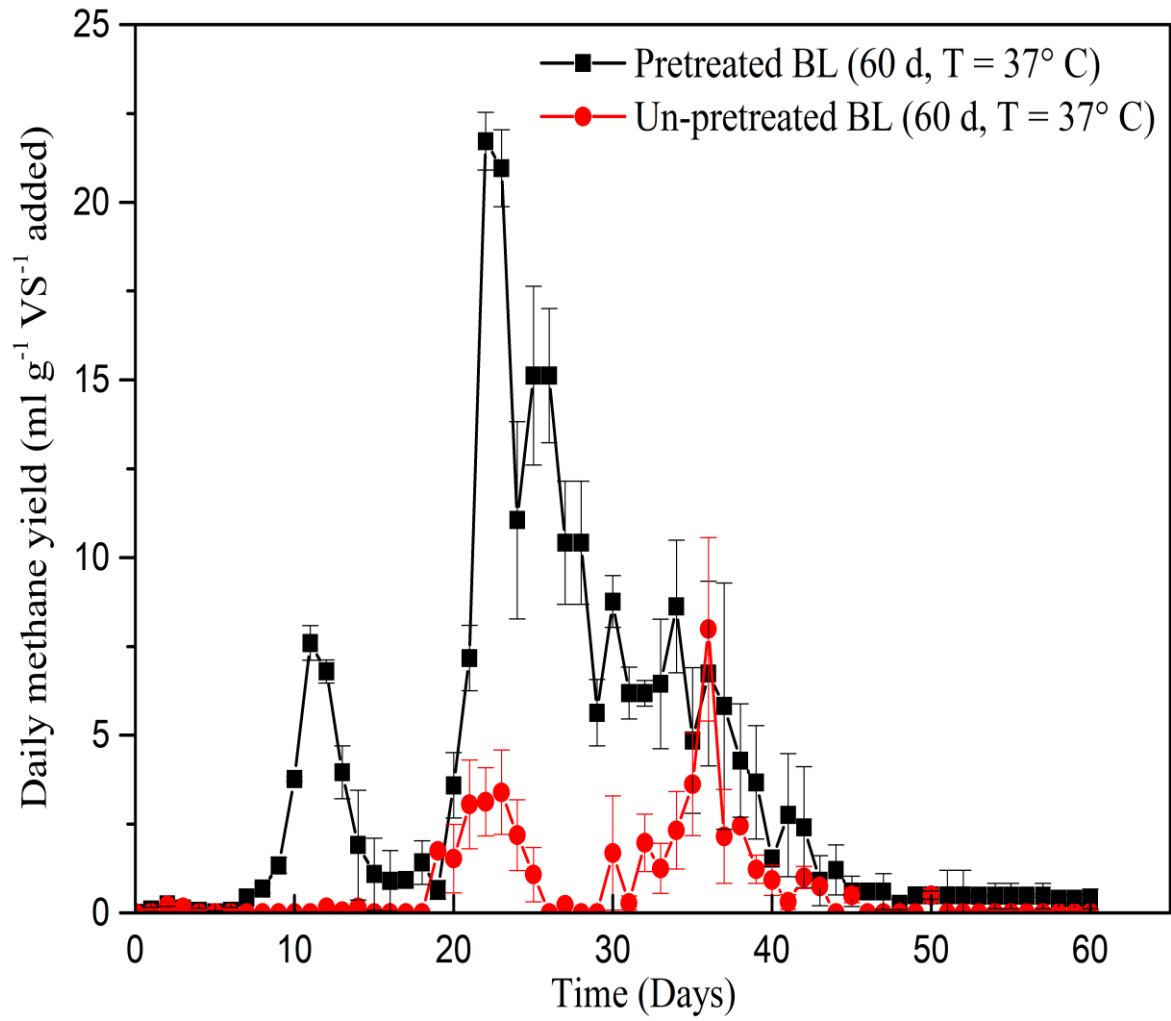

Figure 10: Daily methane yields of pre-treated and un-pretreated banana leaves

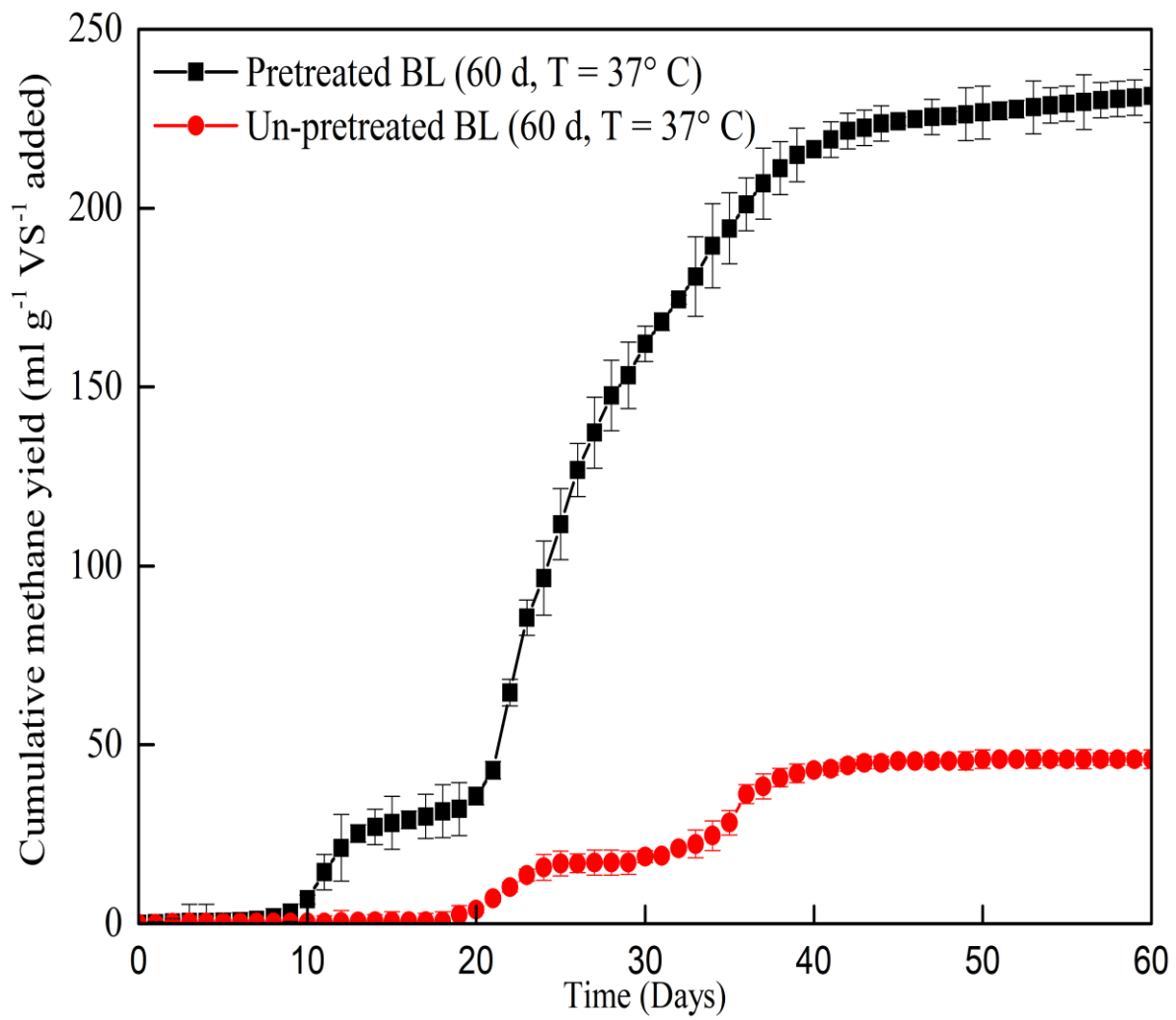

Figure 11: Cumulative methane yields of pre-treated and un-pretreated banana leaves

4.3 The Potential of Edible Clay Soils towards Improving Anaerobic Digestion of Food Wastes for Biogas Recovery

4.3.1 Substrates Characteristics for the Anaerobic Digestion Process

The characterization results for the feedstock are summarized in Table 17. The pH in all reactors; R1: (Food wastes (FW), R2: (96% FW:4% ES) and R3(Inoculum) were 6.43, 6.28 and 7.48, respectively and fall within acceptable ranges of 6.5 to 7.5 for enhancing microorganisms activities for biogas generation (Zhang *et al.*, 2015). The substrates VS in reactors R1, R2 and R3 were 83%, 82% and 82%, respectively, indicating that more digestible organic matters for the AD process were contained in the substrates. The carbon to nitrogen (C/N) ratios were 20.90, 19.92 and 19.35 for the R1, R2 and R3, respectively and therefore, within the acceptable ranges of the AD process as reported in the literature.

Table 17: Characteristics of substrates used in the anaerobic digestion process

Parameters	R1 (FW)	R2 (96% FW + 4% ECS)	R3 (Inoculum)
pH	6.43	6.28	7.48
TS (%)	6.3 ± 0.01	6.3 ± 0.04	5 ± 0.06
VS (% TS)	83 ± 0.09	82 ± 0.02	82 ± 0.03
Alkalinity (mg/L)	838	826	806
VFA (mg/L)	909	910	622
VFA/Alkalinity	1.1	1.1	0.7
Carbon (%)	41.17	39.83	41.41
Hydrogen (%)	5.21	5.32	5.51
Nitrogen (%)	1.97	2.00	2.14
C/N	20.90	19.92	19.35

4.3.2 Trace Elements in Edible Clay Soils

Table 18 depicts the macronutrients, trace and heavy metal elements contents in edible clay soils widely consumed by pregnant women (Mwalongo & Mohammed, 2013). With the exception of Iron (Fe) and Chromium (Cr), all other trace elements and heavy metals (Copper (Cu), Zinc (Zn),

Cobalt (Co), Molybdenum (Mo), Selenium (Se), Manganese (Mn), Nickel (Ni), Arsenic (As), Cadmium (Cd), Lead (Pb) and Uranium (U) in edible clay soils were at a relatively lower concentration as compared to macronutrients; Sodium (Na), Potassium (K), Calcium (Ca) and Magnesium (Mg). The concentration of macronutrients and trace elements are summarized in Table 19. The observed concentrations are comparable to the acceptable range for enhancing microorganism's metabolic activities reported in the literature (Banks *et al.*, 2012; Wei *et al.*, 2014; Zhang *et al.*, 2013; Zhang & Jahng, 2012; Zhang *et al.*, 2011). Edible clay soils in Tanzania, although widely consumed by pregnant women, have some elements (As, Cd, Pb, U) which are above WHO permissible limits recommended for human consumption for different kinds of foods (As 0.01-0.5 mg/kg, Cd: 0.05 - 0.5 mg/kg Pb: 0.01-1mg/kg) (FAO/WHO, 2019). Similar observations for the high concentrations of heavy metals in edible clay soils above acceptable standards obtained in different Tanzania regions were also reported by Mwalongo and Mohammed (2013). Thus, the alternative use of edible clay soils for improving anaerobic digestion performance could be an attractive option.

Table 18: Macronutrients, trace and heavy metal elements in edible clay soils (Mean \pm standard deviations of three replicates)

Element	Value in mg/kg	Element	Value in mg/kg
Sodium (Na)	1500 \pm 0.0	Selenium (Se)	0.67 \pm 0.1
Potassium (K)	170.7 \pm 14.5	Manganese (Mn)	49.6 \pm 6.9
Calcium (Ca)	395.7 \pm 7.5	Nickel (Ni)	91.4 \pm 4.8
Magnesium (Mg)	263.3 \pm 5.8	Arsenic (As)	1.37 \pm 0.1
Copper (Cu)	37 \pm 1.5	Chromium (Cr)	374.3 \pm 16.8
Iron (Fe)	95 083.3 \pm 506.4	Cadmium (Cd)	8.6 \pm 3.6
Zinc (Zn)	33.2 \pm 0.9	Lead (Pb)	20.2 \pm 0.8
Cobalt (Co)	36.5 \pm 0.9	Uranium (U)	2.2 \pm 0.5
Molybdenum (Mo)	26.3 \pm 0.9		

4.3.4 Effect of Edible Clay Soil Supplementation on Methane Yield

Figures 12-15 indicate that the addition of edible clay soils rich in macro and trace elements has significantly improved the FW's methane yield. From day 1 to day 6, the methane yield in the reactor with no ECS supplementation was higher than methane yields in a reactor with ECS supplementation. However, from day 7 and most days after that, the methane yield in a reactor with ECS supplementation surpassed the reactor with no ECS supplementation. This indicated that the methanogenic stage works better under TE supplementation was already attained in a reactor with ECS supplementation. The peak daily biogas yields in both reactors were observed on day 21 and were $44.80 \text{ L kg}^{-1} \text{ VS}^{-1} \text{ d}^{-1}$ and $40.84 \text{ L kg}^{-1} \text{ VS}^{-1} \text{ d}^{-1}$ in the reactor with and without ECS supplementation, respectively.

The cumulative biogas and methane yield in the reactor with ECS supplementation were $742.42 \text{ L kg}^{-1} \text{ VS}^{-1}$ and $344.69 \text{ CH}_4 \text{ L kg}^{-1} \text{ VS}^{-1}$, respectively, which were about 6.22% and 26.9% increase compared to the yields in a reactor with no ECS supplementation. The increase of biogas and methane yields in a reactor with ECS supplementation is attributed to the higher trace elements in edible clay soils. These findings are supported with some previous results in that adding TE in AD process of organic substrates through the addition of materials rich in TE or through direct supplementation with external TE would improve biogas production. Zhang *et al.* (2011) observed a 50% increase in methane yields when the piggery wastes contained higher concentrations of TE was co-digested with food wastes (FW). Banks *et al.* (2012) indicated an improvement in process stability of the AD process when Cobalt and selenium were directly supplemented in the AD process of FW.

Similarly, Zhang and Jahng (2012) indicated that stable operations were achieved in long term AD of FW upon TE supplementation. Thus, this research has paved the way for applying edible clay soils to improve methane yield in the AD process. And this is beneficial since their application as edible material poses a potential risk in human health due to high concentration of toxic elements above acceptable standards by the Food and Agriculture Organization of the United Nations and World Health Organization:

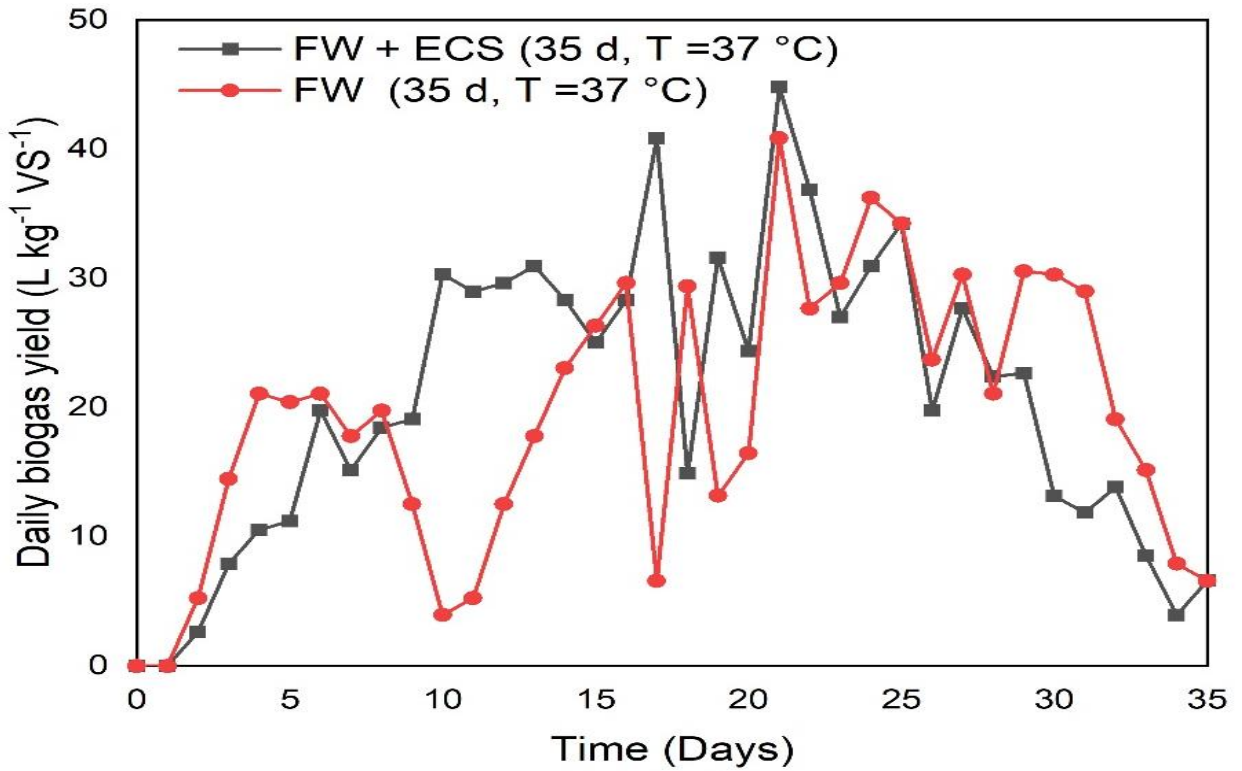

Figure 12: Daily biogas yields of food wastes and food wastes supplemented with edible clay

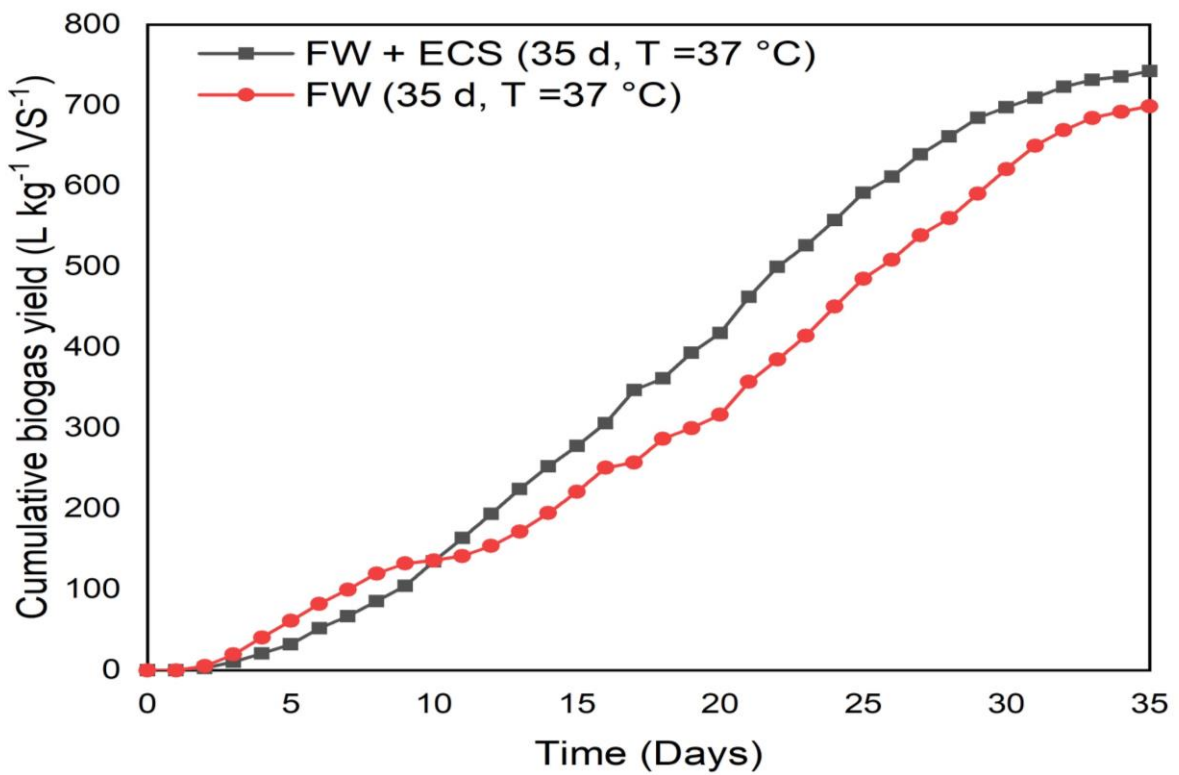

Figure 13: Cumulative biogas yields of food wastes and food wastes supplemented with edible clays soils

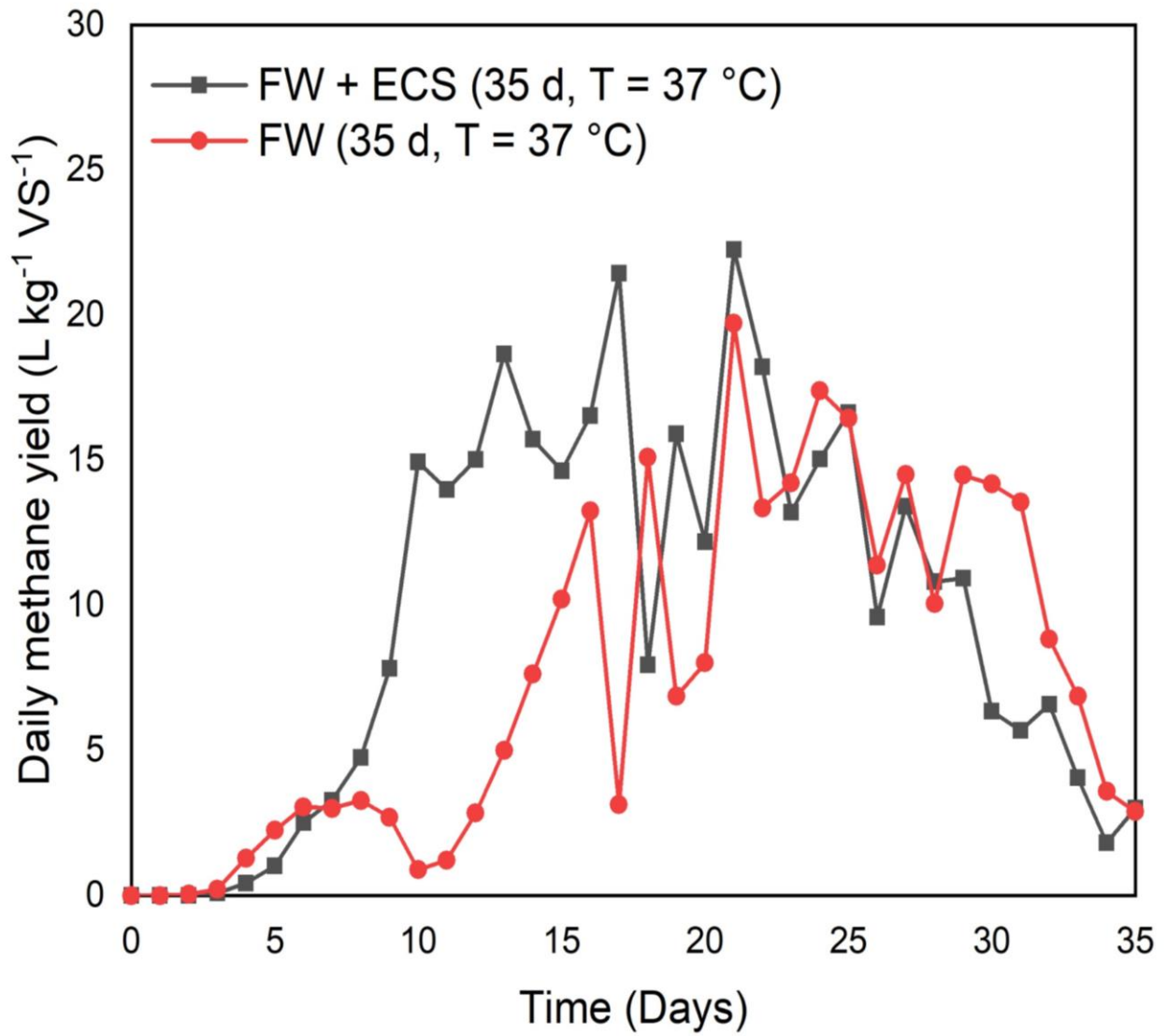

Figure 14: Daily methane yields of food wastes and food wastes supplemented with edible clays soils

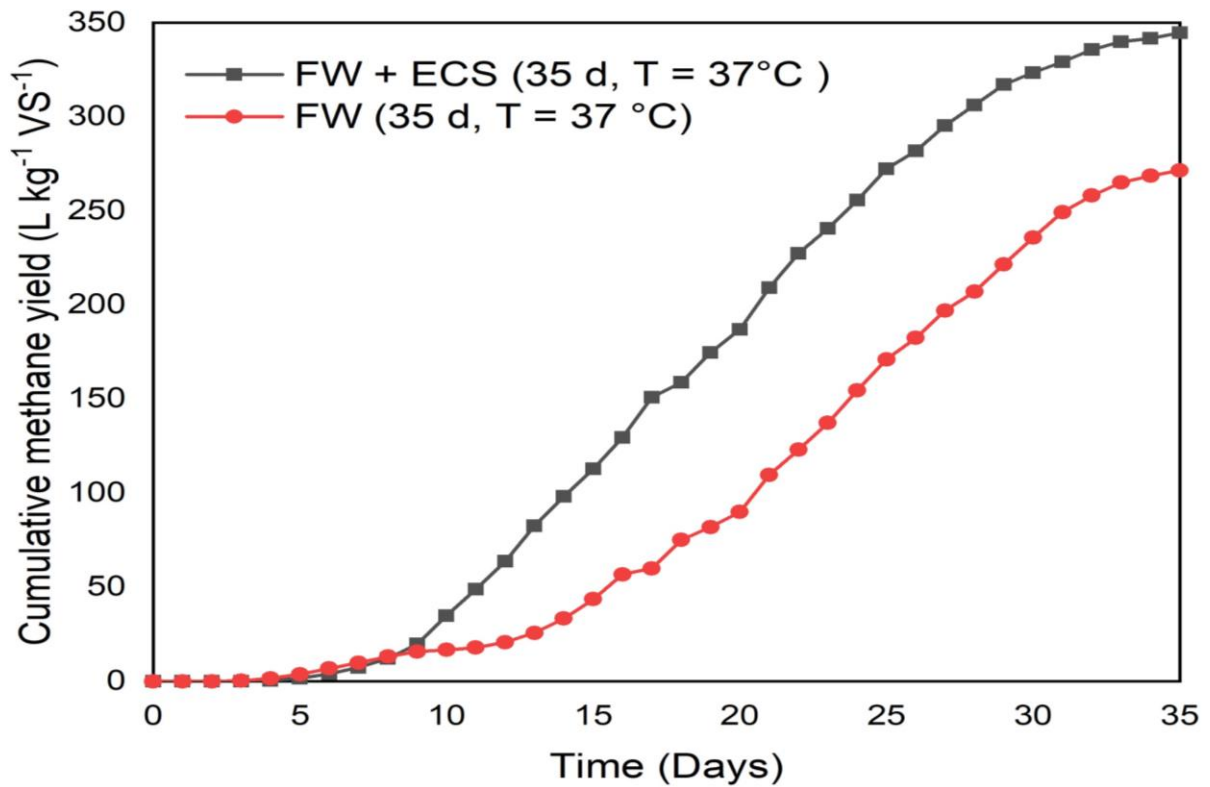

Figure 15: Cumulative methane yields of food wastes and food wastes supplemented with edible clays soils

4.3.5 Effect of Edible Clay Soil Supplementation on Methane Contents

Figure 16 shows that in the first 6 days of the experiment, the reactor with no ECS supplementation has relative high methane content compared to the reactor with ECS supplementation (0%, 0.8%, 1.5%, 6.1%, 11%, and 14.5% versus 0%, 0.3%, 1.2%, 4.1%, 9.2% and 12.7%). However, from day 7 to 18, the reactor with ECS supplementation had a relative higher methane content (21.7 - 60.3%) than the reactor with no ECS supplementation (16.9 - 51.4%). On day 19, the reactor with no ECS observed a high methane content of 52.1% compared to 50.3% methane content in the reactor with ECS supplementation. From Day 20 until when the experiment was stopped on day 35, the methane contents in the reactor with ECS supplementation ranged from 45.7% to 50%, whereas in the reactor with no ECS supplementation, the methane contents observed ranged from 44% to 48.7%, which were statistically significant ($P < 0.05$). In general, the results indicate that ECS is a potential material for enhancing the metabolic stages process and improving methane yield during the anaerobic digestion process.

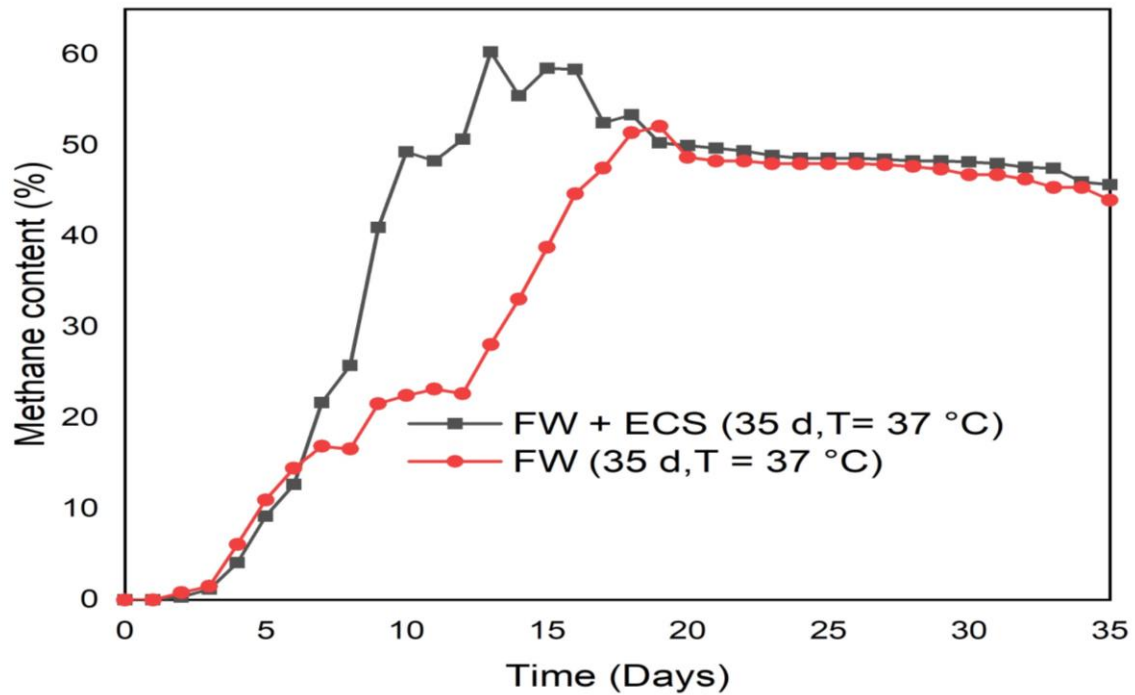

Figure 16: Daily methane contents during anaerobic digestion of supplemented and non-supplemented food wastes with edible clays soils

4.4 Analysis of the Environmental Impacts of Anaerobic Digestion and other Municipal Solid Waste Management Scenarios in the Arusha City of Tanzania

4.4.1 Environmental Impacts of Systems without Resources Recovery

Figure 17 depicts the environmental impact (EI) categories of each scenario without the electricity and compost recovery. The SN-1 showed high IE on most categories except for human toxicity and freshwater ecotoxicity. Direct methane emissions and diesel consumptions attributed to the high EI on SN-1 during the compaction process. The decomposition of the biodegradable wastes produces emissions in all scenarios. Most of the methane generated in a landfill is not captured, resulting in high climate change and photochemical oxidant formation in SN-1 than in composting (SN-2) and anaerobic digestion (SN-3). Maalouf and El-Fadel (2017) made similar observations, who indicated that methane emissions in a landfill are the major contributor to climate change and photochemical oxidant formation. Thus, diverting the organic waste fractions to composting or anaerobic digestion process would significantly reduce climate change and photochemical oxidant formation. SN-1 has a higher terrestrial ecotoxicity compared to other scenarios due to higher diesel consumptions since all wastes are assumed to be compacted during

the landfilling process. Whereas in SN-2 and SN-3, water emissions were not considered, in SN-1, water emissions resulted in higher freshwater eutrophication due to total nitrogen and total phosphorus nutrients emissions. Landfilling of papers and plastics were the dominant factors for human toxicity and freshwater ecotoxicity in all scenarios. Since the same amount of papers and plastics are assumed to be landfilled in all scenarios, there were slight differences in impact categories of human toxicity and freshwater ecotoxicity between scenarios. For composting (SN-2), ammonia emission was a dominant factor for particulate matter formation and terrestrial acidification impact categories. A large fraction of the nitrogen is lost as ammonia during the composting process causing high ammonia emission in composting (SN-2) than in landfill (SN-1) and AD (SN-3) (Haaren *et al.*, 2010).

The literature points out that environmental emissions minimization in a composting process can be achieved using the odour removal devices and promoting home composting to minimize emissions due to the transport process (Haaren *et al.*, 2010; Oyoo *et al.*, 2014). Besides landfilling of paper and plastics in SN-3, electricity consumptions, ammonia and methane emissions were the dominant factors for freshwater eutrophication, particulate matter formation, and climate change, respectively. Anaerobic digestion (SN-3) high amount of methane is generated, but the high percentage is captured for electricity generation (Belboom *et al.*, 2013). The methane generation in composting (SN-2) is very low as compared to the landfill (SN-1) and anaerobic digestion (SN-3) in such a way that some pieces of literature assume no CH₄ is emitted during the composting process (Boldrin *et al.*, 2009).

Figure 18 indicates the percentage of contributions of the major substances to the impact categories. Results showed that for freshwater eutrophication, phosphorus was a dominant contributor for SN-1, phosphate for SN-2 and electricity for SN-3, for the all-scenarios manganese contributed most to human toxicity. For particulate matter formation and terrestrial acidification, ammonia was the dominant factor for SN-2 and SN-3, while diesel was the dominant factor for SN-1. For all scenarios, copper was the dominant contributor to freshwater ecotoxicity. In climate change, methane was the main contributor to all scenarios. In terrestrial ecotoxicity, diesel was the main contributor for SN-2 and SN-3. In photochemical oxidant formation, methane contributed most in SN-1, whereas nitrogen oxides contributed most in SN-2 and SN-3.

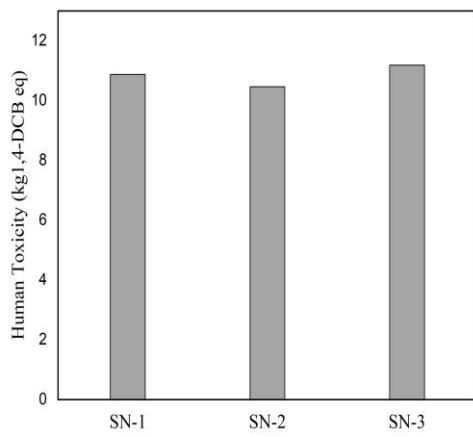

(a) Human Toxicity

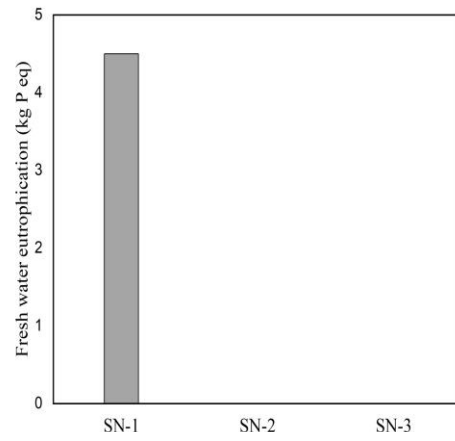

(b) Freshwater eutrophication

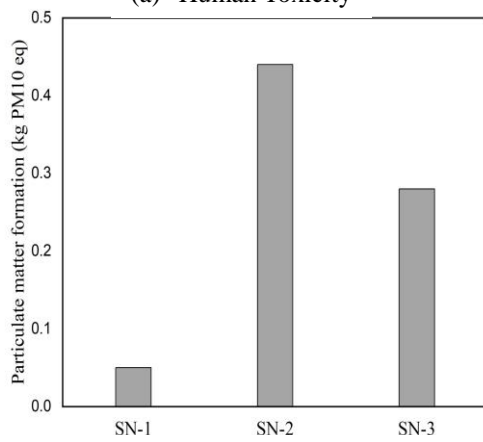

(c) Particulate matter formation

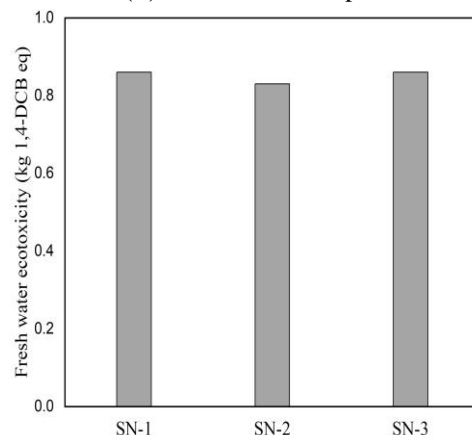

(d) Freshwater ecotoxicity

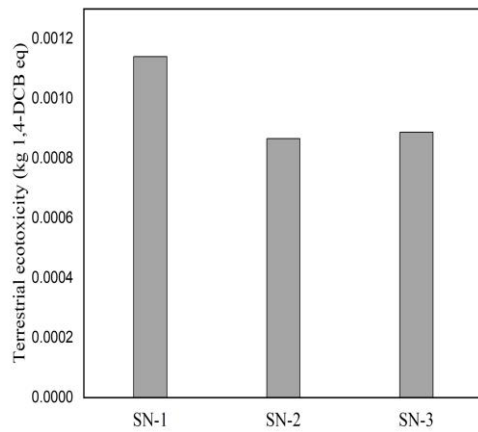

(e) Terrestrial ecotoxicity

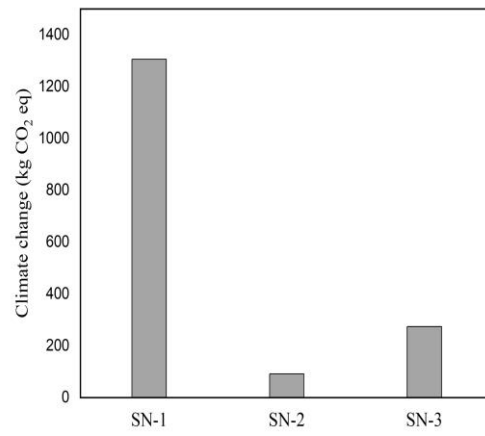

(f) Climate change

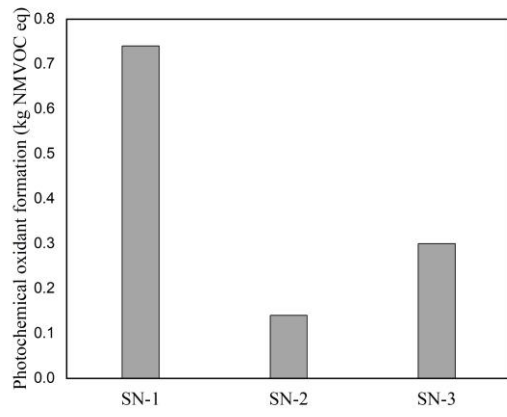

(g) Photochemical oxidant formation

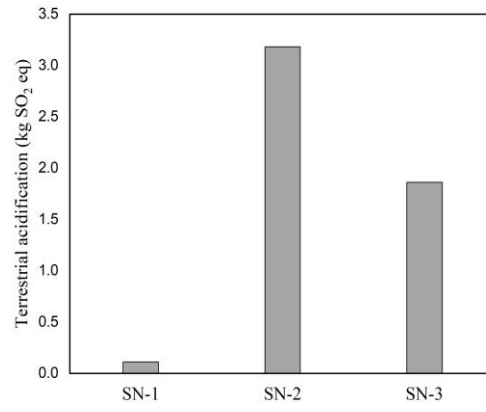

(h) Terrestrial acidification

Figure 17: Environmental impacts of systems (a, b, c, d, e, f, g and h) without resources recovery

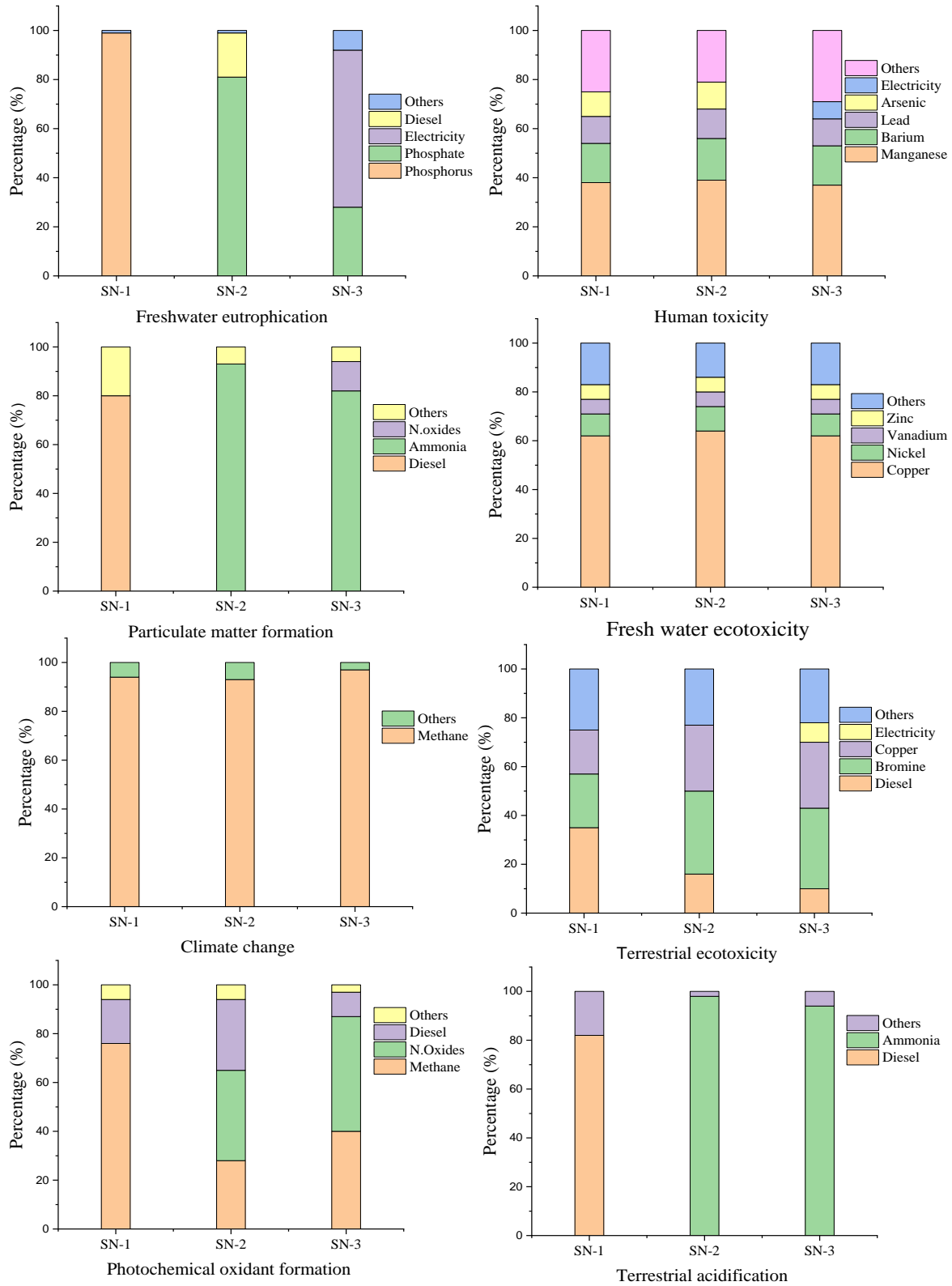

Figure 18: Percentage contributions of the major substances to the impact categories

4.4.2 Impacts of the Resource Recovery

Table 19 and 20 depict the environmental impacts for producing hydropower electricity and mineral fertilizer computed from ecoinvent v.3.6 of the Umberto software. The avoided environmental burdens were subtracted from the total environmental burdens without resource recovery, and their results are shown in Table 21. Results indicated that incorporating resources recovery resulted in improved environmental burdens, although it did not alter the ranking of categories in most impact categories. In AD (SN-3), the digestate recovery compared with the recovery of electricity contributed to most impact categories except for freshwater ecotoxicity and climate change, of which electricity was the main factor. The lower contribution by electricity recovery in SN-3 is attributed to the fact that the hydro-based power source considered in the analysis, compared to other power sources, has lower environmental emissions (Rajaeifar *et al.*, 2015). The avoided emissions resulting from producing chemical fertilizers (N, P₂O₅, and K₂O) due to compost and digestate recovery in SN-2 and SN-3 affected mostly human toxicity impact, making SN-3 much better than SN-1, whereas SN-2 remained the most favoured scenario in this category.

Table 19: Environmental impacts from the production of hydropower electricity

Category	Unit	Value		
		1 kWh	43.55 kWh	135.35 kWh
		Baseline	SN-1 (RCL_LF)	SN-3 (RCL_AD_L)
Fresh water eutrophication	kg P eq	1.56×10^{-6}	6.77×10^{-5}	2.14×10^{-4}
Human toxicity	kg 1,4-DCB eq	2.07×10^{-3}	0.09	0.28
Particulate matter formation	kg PM10 eq	2.07×10^{-5}	9.02×10^{-4}	2.84×10^{-3}
Fresh water ecotoxicity	kg 1,4-DCB eq	1.84×10^{-4}	8.01×10^{-3}	0.03
Climate change	kg CO ₂ eq	0.06	2.83	8.91
Terrestrial ecotoxicity	kg 1,4-DCB eq	5.34×10^{-7}	2.33×10^{-5}	7.33×10^{-5}
Photochemical oxidant formation	kg NMVOC eq	3.81×10^{-5}	1.66×10^{-3}	5.23×10^{-3}
Terrestrial acidification	kg SO ₂ eq	2.11×10^{-5}	9.19×10^{-4}	2.90×10^{-3}

SN: Scenario, RCL: Recycling, LF: Landfilling, CP: Composting, AD: Anaerobic digestion

Table 20: Environmental impacts from the production of mineral fertilizers options

Category	Unit	Scenario	Value			Total
			Fertilizer Nitrogen	Fertilizer Phosphate	Fertilizer Potassium	
Fresh water eutrophication	kg P eq	SN-2	5.1×10^{-4}	7.8×10^{-4}	1.2×10^{-4}	1.4×10^{-3}
		SN-3	6.3×10^{-4}	4.3×10^{-4}	2.0×10^{-5}	1.1×10^{-3}
Human toxicity	kg1,4-DCB eq	SN-2	0.99	0.54	0.19	1.72
		SN-3	1.23	0.3	0.03	1.56
Particulate matter formation	kg PM10 eq	SN-2	4.9×10^{-3}	3.7×10^{-3}	1.4×10^{-3}	1.0×10^{-2}
		SN-3	6.1×10^{-3}	2.0×10^{-3}	2.4×10^{-4}	8.3×10^{-3}
Fresh water ecotoxicity	kg 1,4-DCB eq	SN-2	0.15	0.07	0.02	2.4×10^{-1}
		SN-3	0.18	0.04	3.0×10^{-3}	2.2×10^{-1}
Climate change	kg CO ₂ eq	SN-2	3.62	0.7	0.68	5.00
		SN-3	4.48	0.38	0.12	4.98
Terrestrial ecotoxicity	kg 1,4-DCB eq	SN-2	2.8×10^{-4}	2.8×10^{-4}	1.2×10^{-4}	6.8×10^{-4}
		SN-3	3.5×10^{-4}	1.5×10^{-4}	2.1×10^{-5}	5.2×10^{-4}
Photochemical oxidant formation	kg NMVOC eq	SN-2	8.9×10^{-3}	3.2×10^{-3}	3.3×10^{-3}	1.5×10^{-2}
		SN-3	0.01	1.7×10^{-3}	5.5×10^{-4}	1.2×10^{-2}
Terrestrial acidification	kg SO ₂ eq	SN-2	0.02	7.7×10^{-3}	3.5×10^{-3}	3.1×10^{-2}
		SN-3	0.02	4.2×10^{-3}	6.0×10^{-4}	2.5×10^{-2}

SN-2; (RCL_CP_LF) and SN-3; (RCL_AD_LF), where RCL: Recycling, LF: Landfilling, CP: Composting, AD: Anaerobic digestion

Table 21: Environmental impact categories result with resources recovery

Category	Unit	SN-1	SN-2	SN-3
		RCL_LF	RCL_CP_LF	RCL_AD_LF
		Value		
Fresh water eutrophication	kg P eq	4.499	-7.67×10^{-4}	3.69×10^{-4}
Human toxicity	kg1,4-DCB eq	10.780	8.740	9.340
Particulate matter formation	kg PM10 eq	0.0491	0.429	0.269
Fresh water ecotoxicity	kg 1,4-DCB eq	0.852	0.590	0.607
Climate change	kg CO ₂ eq	1302.630	86.040	259.830
Terrestrial ecotoxicity	kg 1,4-DCB eq	1.120×10^{-3}	1.850×10^{-4}	2.940×10^{-4}
Photochemical oxidant formation	kg NMVOC eq	0.738	0.125	0.282
Terrestrial acidification	kg SO ₂ eq	0.109	3.149	1.832

SN: Scenario, RCL: Recycling, LF: Landfilling, CP: Composting, AD: Anaerobic digestion

4.4.3 Sensitivity Analysis

(i) Sensitivity to Processes Improvement

The sensitivity results indicated in Table 22 show that reducing methane emissions to the environment brought environmental benefits in all scenarios of which SN-1 was highly impacted. The impacted categories were climate changes in all scenarios, photochemical oxidant formation in SN-1 and SN-3 and terrestrial acidification in SN-1. Improving electricity consumption efficiency had the highest environmental impact benefits in SN-3 and impacted on impact categories of freshwater eutrophication, human toxicity, climate change and terrestrial ecotoxicity.

In SN-1 efficiency of electricity, consumptions brought some environmental benefits only in climate change and had no impact on SN-2. Reducing ammonia emissions had lower impacts in most categories except for the particulate matter formation and terrestrial acidification in SN-2 and SN-3.

Improving recycling of paper and plastics exhibited higher environmental impacts benefits in most categories of all the scenarios except for the particulate matter formation, photochemical oxidant formation and terrestrial acidification. Improvement on diesel consumption had a high impact on SN-1 in most categories except for freshwater eutrophication, particulate matter formation and freshwater ecotoxicity. In SN-2 and SN-3, the improvement in diesel consumptions impacted climate change, terrestrial ecotoxicity, freshwater eutrophication (only SN-2) and human toxicity (only SN-3). Generally, we can observe that improving diesel consumptions, reducing methane emissions to air and increasing the recycling rate of papers and plastics are the main factors that would impact all scenarios.

(ii) Sensitivity to Life Cycle Impact Assessment Methods

International Life Cycle Data system (ILCD) 2.0 2018 midpoint and Intergovernmental Panel on Climate Change (IPCC) 2013 impact methods were used to compare the results obtained in ReCiPe 2008 Midpoint (H). V1.13 as indicated in Table 23. The results of ILCD 2.0 2018 midpoint and IPCC 2013 were similar to those of ReCiPe in the photochemical oxidant formation and freshwater eutrophication. For climate change, the LCIA results obtained from ILCD 2.0 2018 midpoint and IPCC 2013 were higher than those from ReCiPe. The difference in results could be attributed to the fact that the ILCD adapted the IPCC 2013 model with the carbon feedbacks of which the methane's 100-year global warming potential is 34, the IPCC 2013 method in ecoinvent V3.6 of Umberto software database has the methane's 100 year potential of 28 (with no carbon adjustment). The ReCiPe method considers the methane's 100-year global warming potential to be 22 (Timmer *et al.*, 2020).

For freshwater ecotoxicity and terrestrial acidification, it was difficult to compare LCIA results obtained from ReCiPe to those of ILCD 2.0 2018 because of the units used and the failure to obtain their conversion factors. Other factors such as human toxicity, particulate matter formation, and terrestrial ecotoxicity were not compared because ILCD 2.0 2018 and IPCC 2013 are not

quantified. Another limitation on assessing the impact methods was due to the license limitation of the Umberto software that had only a few updated LCIA methods from ecoinvent database version 3.6. Based on the comparisons made between ReCiPe, ILCD 2.0 2018 and IPCC 2013 methods, the ReCiPe was consistent for photochemical oxidant formation and freshwater eutrophication.

Table 22: Sensitivity analysis on 5% improvement of process and resources recoveries

Categories	Unit		Electricity	CH ₄	Diesel	Paper	Plastic	NH ₃
Freshwater eutrophication	kg P eq	SN-1	-	-	-	-	-	-
		SN-2	-	-	6×10^{-6}	2×10^{-5}	1×10^{-6}	-
		SN-3	5×10^{-5}	-	-	2×10^{-5}	-	-
Human toxicity	kg 1,4-DCB eq	SN-1	-	-	0.02	0.41	0.11	-
		SN-2	-	-	-	0.4	0.11	-
		SN-3	0.04	-	0.01	0.41	0.12	-
Particulate matter formation	kg PM10 eq	SN-1	-	-	-	-	-	-
		SN-2	-	-	-	-	-	0.02
		SN-3	-	-	-	-	-	0.01
Freshwater ecotoxicity	kg 1,4-DCB eq	SN-1	-	-	-	0.02	0.02	-
		SN-2	-	-	-	0.02	0.02	-
		SN-3	-	-	-	0.02	0.02	-
Climate change	kg CO ₂ eq	SN-1	0.02	61.3	0.49	3.68	0.03	-
		SN-2	-	0.93	0.18	3.68	0.03	-
		SN-3	0.1	10.0	0.1	3.68	0.03	-
Terrestrial ecotoxicity	kg 1,4-DCB eq	SN-1	-	-	2×10^{-5}	1×10^{-5}	1×10^{-5}	-
		SN-2	-	-	8×10^{-6}	6×10^{-6}	1×10^{-5}	-
		SN-3	3×10^{-6}	-	4×10^{-6}	6×10^{-6}	1×10^{-5}	-
Photochemical oxidant formation	kg NMVOC eq	SN-1	-	0.03	0.01	-	-	-
		SN-2	-	-	-	-	-	-
		SN-3	-	0.01	-	-	-	-
Terrestrial acidification	kg SO ₂ eq	SN-1	-	0.01	0.01	-	-	-
		SN-2	-	-	-	-	-	0.16
		SN-3	-	-	-	-	-	0.08

SN-1; RCL_LF, SN-2; (RCL_CP_LF) and SN-3; (RCL_AD_LF), where RCL: Recycling, LF: Landfilling, CP: Composting, AD: Anaerobic digestion

Table 23: Compared ReCiPe 2008 Midpoint (H). V1.13 results with other life cycle impact assessment methods without resources recovery

Category	Unit	Scenarios	ReCiPe	ILCD	IPCC 2013
Fresh water eutrophication	kg P eq	SN-1	4.5	4.5	-
		SN-2	6.42×10^{-4}	6.42×10^{-4}	-
		SN-3	1.66×10^{-3}	1.66×10^{-3}	-
Human toxicity	kg1,4-DCB eq	SN-1	10.87	-	-
		SN-2	10.46	-	-
		SN-3	11.18	-	-
Particulate matter formation	kg PM10 eq	SN-1	0.05	-	-
		SN-2	0.44	-	-
		SN-3	0.28	-	-
Fresh water ecotoxicity	kg 1,4-DCB eq	SN-1	0.86	6.24 CTU	-
		SN-2	0.83	4.69 CTU	-
		SN-3	0.86	5.02 CTU	-
Climate change	kg CO ₂ eq	SN-1	1305.46	1984.1	1665.15
		SN-2	91.04	135.81	114.77
		SN-3	273.72	413.9	348
Terrestrial ecotoxicity	kg 1,4-DCB eq	SN-1	1.14×10^{-3}	-	-
		SN-2	8.66×10^{-4}	-	-
		SN-3	8.87×10^{-4}	-	-

Category		Unit	Scenarios	ReCiPe	ILCD	IPCC 2013
Photochemical formation	oxidant	kg NMVOC eq	SN-1	0.74	0.74	-
			SN-2	0.14	0.14	-
			SN-3	0.3	0.3	-
Terrestrial acidification		kg SO ₂ eq	SN-1	0.11	0.14 mol H + Eq	-
			SN-2	3.18	3.92 mol H + Eq	-
			SN-3	1.86	2.31 mol H + Eq	-

SN-1; RCL_LF, SN-2; (RCL_CP_LF) and SN-3; (RCL_AD_LF), where RCL: Recycling, LF: Landfilling, CP: Composting, AD: Anaerobic digestion

4.5 Economic Analysis of Biogas Power Plant in Arusha City

4.5.1 Food Wastes

Arusha City produces about 271 tons of MSW annually; 37% is food waste (Omari *et al.*, 2014). This leads to about 100.27 tons of food wastes (FW) per day. The biodigester size was estimated as per the following assumptions; the feedstock will be diluted with water in a ratio of 1-part water to 1-part wastes, and waste pickers will recover 50% of the feedstock for animal feedings at the landfill. The total daily quantity of the wastes to be treated will therefore be computed as; $50\,135 \text{ kg (Waste)} + 50\,135 \text{ kg (Water)} = 100\,270 \text{ kg}$ (or $100\,270 \text{ litres} = 100.27 \text{ m}^3$) (Since 1 litre of water is typically assumed to be equal to 1 kg). The digester is considered to be working at mesophilic temperatures of 25 to 40 °C with a hydraulic retention time of 40 days.

Therefore, the total active reactor volume that would be required can be estimated to be 4010.8 m^3 ($100.27 \text{ m}^3 \times 40 \text{ days}$). The total volume can be estimated by adding 25% as the gas storage to the active reactor volume. Therefore the total volume of the reactor estimated for treating 50.135 tons/day of food wastes is estimated to be 5013.5 m^3 ($0.25 \times 4010.8 \text{ m}^3 + 4010.8 \text{ m}^3$). Vögeli *et al.* (2014) indicated that a 2 kW generator would require about 24 m^3 of biogas daily. Therefore, with 9375.245 m^3 of the biogas is estimated to be generated daily in this project (See section 4.5.5), about 781.27 kW generator will be required.

4.5.2 Banana Leaves Wastes

Banana leaves wastes (BL) in Arusha City are estimated to be 23.6% of organic market wastes corresponding to 18% of the total market wastes collected and disposed at the Muriet landfill (Quantified under this study in May and September 2019). The Muriet landfill record showed that market waste comprises about 7% of the total waste generated in Arusha City. This means about 3.4 tons of banana leaves are generated daily at Arusha City. The total daily quantity of the wastes to be treated will therefore be computed as; $3400 \text{ kg (Waste)} + 3400 \text{ kg (Water)} = 6800 \text{ kg}$ (or $6800 \text{ litres} = 6.8 \text{ m}^3$) (Since 1 litre of water is typically assumed to be equal to 1 kg).

The digester is assumed to be working at mesophilic temperatures of 25 to 40 °C with a hydraulic retention time of 40 days. Therefore, the total active reactor volume required can be estimated to

be 272 m³ (6.8 m³ x 40 days). The total volume can be estimated by adding 25% as the gas storage to the active reactor volume. Therefore, the total volume of the reactor estimated for treating 3.4 tons/day of banana leaves is estimated to be 340 m³ (0.25 x 272 m³ + 272 m³). With 408 m³ of the biogas estimated to be generated daily in this project, about 34 kW generator will be required.

4.5.3 Investment Cost

Investment costs for biogas plant treating food wastes were estimated as per Table 24.

Table 24: Investment costs for the biogas power plant treating food and banana leaves waste in Arusha City

Item	Feedstock	Capacity	Unit cost (US\$)	Capital cost (US\$)
Biodigester	FW	5013.5 m ³	118 per m ³	591 593.00
	BL	340 m ³		40 120.00
Generator	FW	781.27 kW	320 per kW	250 006.40
	BL	34 kW		10 880.00
Shredder	FW		2 per annual ton of	36 598.55
	BL		Feedstock	2482.00
Shovels	FW		1.5 per annual ton of	27 448.91
	BL		Feedstock	1861.50
TOTAL	FW			905 646.86
	BL			55 343.5

4.5.4 Operation and Maintenance Costs

(i) Food Wastes

The plant equipment's annual repair and maintenance cost is estimated as 5% of the initial capital investments. Therefore, from the investment cost computed above, the annual operation and maintenance cost is estimated to be US\$ 42 282.343. Manual sorting of waste will be applied: For every 2 tons of waste, one labour work per day will be employed and will be paid about

US\$ 150 per month, therefore with 50.135 tons/day, about 25 workers will be utilised to sort out organic matter from the waste's streams, costing about US\$ 3750 per month or US\$ 45 000 per year. Water cost: 50% of the water will be covered by recycled digestate. The rest will be purchased based on the country price rate per cubic meter. The water will be purchased at the rate of US\$ 0.86 per cubic meter (These rates are based on the current Tanzania market). From the estimates on this project, about 50.135 m³ of water will be required daily, of which 50%, which equals 25.07 m³, will be purchased daily with a resultant estimated annual cost of US\$ 7869.47.

Plant operators: The plant will require a plant administrator (US\$ 950 per month), a quality manager (US\$ 600 per month), and two lab technicians (each US\$ 450 per month) who will be paid a lump sum of annual US\$ 29 400. Lab analysis expenses: For monitoring the performance of the biodigester, analysis of important parameters such as chemical oxygen demand, biochemical oxygen demand, volatile fatty acids, total solids will be analyzed. The lumpsum of the estimated cost of the annual US\$ 72 000 is allocated as analysis costs (Assumption has made that 10 biodigesters each 500 m³ will be constructed with a month laboratory analysis costs of US\$ 600 per biodigester). To achieve post-treatment requirements for every 5 tons of waste, one labour work per day will be employed and will be paid about US\$ 200 per month. Therefore, about ten workers will be utilised to operate the windrow composting, costing about US\$ 2000 per month or US\$ 24 000 per year.

(ii) Banana Leaves Wastes

The plant equipment's annual repair and maintenance cost is estimated as 5% of the initial capital investments. Therefore, from the investment cost computed above, the annual operation and maintenance cost is estimated to be US\$ 2767.175. Manual sorting of waste will be applied: For every 2 tons of waste, one labour work per day will be employed and will be paid about US\$ 150 per month, therefore with 3.4 tons/day, about two workers will be utilised to sort out organic matter from the waste's streams, costing about US\$ 300 per month or US\$ 3600 per year. Water cost: 50% of the water will be covered by recycled digestate. From the estimates on this project, about 3.4 m³ of water will be required daily, of which 50%, which equals 1.7 m³, will be purchased daily with a resultant estimated annual cost of US\$ 533.63.

Plant operators: The plant will require a plant administrator (US\$ 950 per month) and one lab

technicians (US\$ 450 per month) who will be paid a lump sum of annual US\$ 16800. Lab analysis expenses are estimated at the annual costs of US\$ 7200 (Assumption has made that one biodigester of 340 m³ will be constructed with a monthly laboratory analysis cost of US\$ 600). To achieve post-treatment requirements, for every 5 tons of waste, one labour work per day will be employed and will be paid about US\$ 200 per month. Therefore, one worker will be utilised to operate the windrow composting, costing about US\$ 200 per month or US\$ 2400 per year. Table 25 summarizes the operation and maintenance cost for the biogas plant treating food wastes and banana leaves wastes as estimated in this project.

Table 25: Operation and maintenance costs for the biogas plant in Arusha City

Item	Annual Costs (US\$)	
	Leave Wastes	Food Wastes Banana
Repair and maintenance costs	42 282.343	2767.175
Sorting costs	45 000	3600
Water cost	7869	534
Biogas plant operators cost	29 000	16 800
Laboratory analysis cost	72 000	7200
Post-treatment costs	24 000	2400
TOTAL	220 151.343	33 301.175

4.5.5 Estimation of the Revenues

(i) Food Wastes

In the AD process of 500 g FW (TS: 29.01%, VS =87.19% before mixing with inoculum), about 742.42 L kg⁻¹ VS⁻¹ of cumulative biogas (Corresponding to 0.187 m³ per 1 kg of Food waste) was obtained. Then 1 ton would produce about 187 m³ of biogas. Then annual biogas for 50.135 ton per day of FW can be estimates as; Annual biogas (m³) = 187 m³/ton x 50.135 ton/d x 365 day/year producing about 3 421 964.425 m³ annually or (9375.245 m³ daily). Annual electricity (kWh): Each 1 m³ of biogas contains approximately 6 kWh of calorific energy (Vögeli *et al.*, 2014). When biogas is converted into electricity, the generator converts about 35% of the biogas into useable electricity. Then basing on this information, the annual electricity in kWh can be

estimated as; $7\ 186\ 125.293\ \text{kWh}$ ($0.35 \times 187\ \text{m}^3/\text{ton} \times 50.135\text{-ton} \times 365\ \text{d/year} \times 6\ \text{kWh}$).

Annual fertilizers (ton): With the anaerobic digestion process, about 0.1 ton of fertilizer can be produced from one ton of organic matter (Khandelwal *et al.*, 2019). Therefore, with 50.135 tons of FW wastes daily produced, the annual fertilizers are estimated at 1829.93 tons ($0.1\ \text{ton/ton of waste} \times 50.135\ \text{ton/day} \times 365\ \text{days/year}$). Revenues generation from biogas plant were considered from the sales of electricity and biofertilizers. Electricity sales prices were estimated at the current electricity cost in Tanzania of US\$ 0.154 per unit kWh. Therefore, with the annual electricity generation of $7\ 186\ 125.293\ \text{kWh}$, about annual US\$ 1 106 663.29 ($7\ 186\ 125.293\ \text{kWh} \times \text{US\$ } 0.154$) will be generated. The organic sales price was estimated at US\$ 23 per metric ton of organic fertilizers (Arati, 2009). Therefore, with the annual biofertilizer generation of about 1829.93 tons, about annual US\$ 42 088.39 ($1829.93\ \text{tons} \times \text{US\$ } 23$) could be generated.

(ii) **Banana Leaves Wastes**

In the AD process of BL, about $583\ \text{mL g}^{-1}\ \text{VS}^{-1}$ of cumulative biogas (Corresponding to $0.120\ \text{m}^3$ per 1 kg of BL) was obtained from 17.5 g of BL. Then 1 ton would produce about $120\ \text{m}^3$ of biogas. Then annual biogas for 3.4 ton per day of BL can be estimated as; Annual biogas (m^3) = $120\ \text{m}^3/\text{ton} \times 3.4\ \text{ton/d} \times 365\ \text{days/year}$, producing about $148\ 920\ \text{m}^3$ annually or ($408\ \text{m}^3$ daily). Then basing on this information, the annual electricity in kWh can be estimated as; $312\ 732\ \text{kWh}$ ($0.35 \times 120\ \text{m}^3/\text{ton} \times 3.4\text{-ton} \times 365\ \text{d/year} \times 6\ \text{kWh}$). Annual fertilizers (ton): With the anaerobic digestion process, about 0.1 ton of fertilizer can be produced from one ton of organic matter (Khandelwal *et al.*, 2019). Therefore, with 3.4 ton of BL waste daily, the annual fertilizers are estimated at 124.1 tons ($0.1\ \text{ton/ton of waste} \times 3.4\ \text{ton/day} \times 365\ \text{days/year}$).

Revenues generation from biogas plant were considered from the sales of electricity and biofertilizers. Electricity sales prices were estimated at the current electricity cost in Tanzania of US\$ 0.154 per unit kWh. Therefore, with the annual electricity generation of $312\ 732\ \text{kWh}$, about a yearly US\$ 48 160.73 ($312\ 732\ \text{kWh} \times \text{US\$ } 0.154$) will be generated. The organic sales price was estimated at US\$ 23 per metric ton of organic fertilizers (Arati, 2009). Therefore, with the annual biofertilizer generation of about 124.1 tons, about annual US\$ 2 854.3 ($124.1\ \text{tons} \times \text{US\$ } 23$) could be generated. Table 26 summarizes the revenue generated for the biogas plant treating food and banana leaves wastes as estimated in this project.

Table 26: Annual revenue for the biogas power plant treating food and banana leaves waste in Arusha City

Items	Feedstock	Revenue from	Revenue from	Total Revenue (US\$)
		Electricity (US\$)	Biofertilizer (US\$)	
Biogas plant	FW	1 106 663.295	42 088.39	1 148 751.685
Biogas plant	BL	48 160.73	2854.3	51 015.03

4.5.6 Economic Analysis Results

Table 27 depicts the economic analysis results for the biogas plant. In general, results indicate that investing in the anaerobic power plant for energy generation from FW and BL is economically viable since the NPV value is positive and contains shorter payback periods. The analysis also shows that investing in the biogas plants in Arusha City for treating FW and BL could lead to the NPV of US\$ 4 628 342 and US\$ 50 222 with a payback period of 1.59 and 6.21 years, respectively.

Table 27: Economic analysis of the biogas power plant

Items	Unit	Amount	
		FW	BL
Capital costs	US\$	905 646.86	55 343.5
Life period	Years	20	20
Amortized capital cost/year	US\$	45 282.34	2767.18
Total expenditure per year	US\$	220 151.343	33 301.175
Total revenues per year	US\$	1 148 751.685	51 015.03
Discount rate	%	10	10
Net present value (NPV)	US\$	4 628 342	50 222
Payback period	Years	1.59	6.21

CHAPTER FIVE

CONCLUSION AND RECOMMENDATIONS

5.1 Conclusion

This thesis examined different strategies to improve the anaerobic digestion process and analyzed the environmental impacts of municipal solid waste management options. The main conclusions that are summarized below are extracted from separate specific objectives in the thesis. Fungal treatment (*Pleurotus ostreatus*) of banana leaves before AD process resulted in the biogas yield of 282 mL g⁻¹ VS⁻¹ and 181 ± 19 g of edible mushrooms per 2 kg of banana leaves waste. The cost analysis revealed that mushroom cultivation has a high economic value and therefore, favoured before the AD process. Pre-treatment of the BL wastes using the banana winery wastewater from the bottle-washing process improved the methane yield by 193% compared to the untreated BL. The improvement of the methane yields was due to the high amount of caustic soda (NaOH), which is added during the bottle washing process. Since most beverage industries generate high amounts of alkaline wastewaters, recovering alkalis such as NaOH (which are very expensive to purchase) from industrial wastewaters could be the less expensive alternative pre-treatment lignocellulosic substrates to improve biogas production. Utilizing locally available edible clay soils rich in trace elements improved the methane yields of the AD process of food wastes by 26.9% when food wastes and edible clay soils were utilized at the ratio of 96% FW (500 g): 4% edible clay soils (20.8 g) as compared to the reactor with no edible clay soils supplementation. The improvement of the methane yields was due to rich amounts of trace elements in edible clay soils. Therefore, since these materials are widely available, their alternative use for improving biogas production could be less expensive and an attractive option. Finally, evaluations on environmental impacts revealed that the AD process outranked the current management option (Landfill) with the least environmental burdens and could help divert waste from the landfills and improve the environmental management of Arusha City and other cities in the developing countries. The study also revealed it is economically viable to implement the biogas plants for treating FW and BL in the Arusha City of Tanzania.

5.2 Recommendations

Based on the findings of this thesis, the following recommendations are provided:

- (i) Because of the heterogeneous composition of organic fraction of municipal solid wastes and the differences in biological efficiencies, further studies with *P. ostreatus* are recommended on other different OFMSW substrates.
- (ii) Since the purchase of pure alkalis is very costly, recovery of alkalis from alkaline industrial wastewaters is recommended for application as low-cost pre-treatment technology for enhancing biogas recovery from lignocellulosic biomass.
- (iii) Future studies on edible clay soils should focus on optimization of the materials and understanding the relationship between microbial activities in response to edible clay soils supplementation on OFMSW during AD.
- (iv) Finally, the anaerobic digestion process is recommended for managing the OFMSW solid wastes in Arusha City and other cities of the developing countries since it has lower environmental burdens when compared with the landfills, which are most often used.
- (v) Economic analysis results indicated that investing the anaerobic power plant for treated food and banana leaves wastes in Arusha City is economically viable with NPV of US\$ 4 628 342 and US\$ 50 222 with the payback periods of 1.59 and 6.21 years, respectively. Further economic studies on other different OFMSW substrates are recommended.

REFERENCES

- Abdel-Hamid, A. M., Solbiati, J. O., & Cann, I. K. O. (2013). Insights into lignin degradation and its potential industrial applications. In G. Gadd, & S. Sariaslani (Eds), *Advances in Applied Microbiology* (pp. 1–28). <https://doi.org/10.1016/B978-0-2-407679-2.00001-6>
- Abduli, M. A., Naghib, A., Yonesi, M., & Akbari, A. (2011). Life cycle assessment (LCA) of solid waste management strategies in Tehran: Landfill and composting plus landfill. *Environmental Monitoring and Assessment*, 178(1–4), 487–498. <https://doi.org/10.1007/s10661-010-1707-x>
- Agbor, V. B., Cicek, N., Sparling, R., Berlin, A., & Levin, D. B. (2011). Biomass pretreatment: Fundamentals toward application. *Biotechnology Advances*, 29(6), 675–685. <https://doi.org/10.1016/j.biotechadv.2011.05.005>
- Akram, M., Ilyas, F., & Garg, H. (2019). Multi-criteria group decision making based on Elimination and Choice Expressing Reality method in Pythagorean fuzzy information. *Soft Computing*, 24, 3425–3453 <https://doi.org/10.1007/s0050-019-04105-0>
- Albornoz, S., Wyman, V., Palma, C., & Carvajal, A. (2018). Understanding of the contribution of the fungal treatment conditions in a wheat straw biorefinery that produces enzymes and biogas. *Journal of Biochemical Engineering*, 140,140-147. <https://doi.org/10.1016/j.bej.2018.09.011>
- Aleluia, J., & Ferrão, P. (2016). Characterization of urban waste management practices in developing Asian countries: A new analytical framework based on waste characteristics and urban dimension. *Waste Management*, 58, 415–429. <https://doi.org/10.1016/j.wasman.2016.05.008>
- Amirta, R., Herawati, E., Suwinarti, W., & Watanabe, T. (2016). Two-steps Utilization of Shorea Wood Waste Biomass for the Production of Oyster Mushroom and Biogas: A Zero Waste Approach. *Agriculture and Agricultural Science Procedia*, 9, 202–208. <https://doi.org/10.1016/j.aaspro.2016.02.127>

- Amlinger, F., Peyr, S., & Cuhls, C. C. (2008). Greenhouse gas emissions from composting and mechanical biological treatment. *Waste Management and Research*, 26(1), 47–60. <https://doi.org/10.1177/0734242X07088432>
- Angelidaki, I., & Ellegaard, L. (2003). Co-digestion of Manure and Organic Wastes in centralized biogas plants. *Applied Biochemistry and Biotechnology*, 109, 95–105. <https://doi.org/10.1385/ABAB:109:1-3:95>
- APHA. (2012). *Standard Methods for the Examination of Water and Wastewater*, 22nd ed. American Public Health Association, Washington, DC, USA. <https://www.standardmethods.org/doi/book/10.2105/SMWW.2882>
- Arati, J. (2009). *Evaluating the Economic Feasibility of Anaerobic Digestion of Kawangware Market Waste [A Thesis for the Degree Master of Agribusiness of Kansas State University]*. <https://core.ac.uk/download/pdf/5166145.pdf>
- Ariunbaatar, J., Panico, A., Esposito, G., Pirozzi, F., & Lens, P. N. L. (2014). Pretreatment methods to enhance anaerobic digestion of organic solid waste. *Applied Energy*, 123, 143–156. <https://doi.org/10.1016/j.apenergy.2014.02.035>
- Atasoy, M., Owusu-Agyeman, I., Plaza, E., & Cetecioglu, Z. (2018). Bio-based volatile fatty acid production and recovery from waste streams: Current status and future challenges. *Bioresource Technology*, 268, 773–786. <https://doi.org/10.1016/j.biortech.2018.07.042>
- Babu, G. L. S., Lakshmikanthan, P., & Santhosh., L. G. (2014). *Life cycle Analysis of Municipal Solid Waste (MSW) Land Disposal Options in Bangalore City. In International Conference on Sustainable Infrastructure*. <https://doi.org/10.1061/9780784478745.075>
- Baek, G., Kim, J., Kim, J., & Lee, C. (2018). Role and potential of direct interspecies electron transfer in anaerobic digestion. *Energies*, 11(1), 1-17. <https://doi.org/10.3390/en11010107>
- Banks, C. J., Salter, A. M., Heaven, S., & Riley, K. (2011). Resources, Conservation and Recycling Energetic and environmental benefits of co-digestion of food waste and cattle slurry: A preliminary assessment. *Resources, Conservation & Recycling*, 56(1), 71–79. <https://doi.org/10.1016/j.resconrec.2011.09.006>

- Banks, C. J., Zhang, Y., Jiang, Y., & Heaven, S. (2012). Trace element requirements for stable food waste digestion at elevated ammonia concentrations. *Bioresource Technology*, 104, 127–135. <https://doi.org/10.1016/j.biortech.2011.10.068>
- Bari, E., Nazarnezhad, N., Kazemi, S. M., Tajick, G. M. A., Mohebby, B., Schmidt, O., & Clausen, C. A. (2015). Comparison between degradation capabilities of the white rot fungi *Pleurotus ostreatus* and *Trametes versicolor* in beech wood. *International Biodeterioration and Biodegradation*, 104, 231–237. <https://doi.org/10.1016/j.ibiod.2015.03.033>
- Behera, S., Arora, R., Nandhagopal, N., & Kumar, S. (2014). Importance of chemical pretreatment for bioconversion of lignocellulosic biomass. *Renewable and Sustainable Energy Reviews*, 36, 91–106. <https://doi.org/10.1016/j.rser.2014.04.047>
- Belboom, S., Digneffe, J. M., Renzoni, R., Germain, A., & Léonard, A. (2013). Comparing technologies for municipal solid waste management using life cycle assessment methodology: A Belgian case study. *International Journal of Life Cycle Assessment*, 18(8), 1513–1523. <https://doi.org/10.1007/s11367-013-0603-3>
- Bellettini, M. B., Fiorda, F. A., Maieves, H. A., Teixeira, G. L., Ávila, S., Hornung, P. S., Junior, A. M., & Ribani, R. H. (2016). Factors affecting mushroom *Pleurotus* spp. *Saudi Journal of Biological Sciences*, 26(4), 633–646. <https://doi.org/10.1016/j.sjbs.2016.12.005>
- Bhatti, M., Jiskani, M., Wagan, K., Pathan, M., & Magsi, M. (2007). Growth, development and yield of oyster mushroom, *Pleurotus ostreatus* (Jacq. Ex. Fr.) Kummer as affected by different spawn rates. *Pakistan Journal of Botany*, 39(7), 2685–2692.
- Björn, A., Ziels, R. M., Gustafsson, K., Shakeri, S., Karlsson, A., Gustafsson, K., & Karlsson, A. (2017). Feasibility of organic fraction of municipal solid wastes co-digestion with sewage sludge for increasing biogas production at wastewater treatment plants. *Euro-Mediterranean Journal for Environmental Integration*, 2(1), 1–10. <https://doi.org/10.1007/s41207-017-0031-z>

- Bodík, I., & Kubaská, M. (2013). Energy and sustainability of operation of a wastewater treatment plant. *Environment Protection Engineering*, 39(2), 15–24. <https://doi.org/10.5277/EPE130202>
- Boldrin, A., Andersen, J. K., Møller, J., Christensen, T. H., & Favoino, E. (2009). Composting and compost utilization: Accounting of greenhouse gases and global warming contributions. *Waste Management and Research*, 27(8), 800–812. <https://doi.org/10.1177/0734242X09345275>
- Buchauer, K. (1998). A comparison of two simple titration procedures to determine volatile fatty acids in influents to waste-water and sludge treatment processes. *Water South Africa*, 24(1), 49–56.
- Budzianowski, W. M. (2016). A review of potential innovations for production, conditioning and utilization of biogas with multiple-criteria assessment. *Renewable and Sustainable Energy Reviews*, 54, 1148–1171. <https://doi.org/10.1016/j.rser.2015.0.054>
- Bundgaard, S. S., Kofoed-Wiuff, A., Herrmann, I. T., & Karlsson, K. B (Eds.). (2014). *Experiences with Biogas in Denmark*. DTU Management Engineering. <https://orbit.dtu.dk/en/publications/experiences-with-biogas-in-denmark>
- Bustamante, M. A., Moral, R., Bonmatí, A., Palatsí, J., Solé-Mauri, F., & Bernal, M. P. (2014). Integrated waste management combining anaerobic and aerobic treatment: A Case Study. *Waste and Biomass Valorization*, 5, 481–490. <https://doi.org/10.1007/s12649-013-9260-9>
- Cesaro, A., & Belgiorno, V. (2014). Pretreatment methods to improve anaerobic biodegradability of organic municipal solid waste fractions. *Chemical Engineering Journal*, 240, 24–37. <https://doi.org/10.1016/j.cej.2013.11.055>
- Chaiyapong, P., & Chavalparit, O. (2016). Enhancement of biogas production potential from Acacia leaf waste using alkaline pre-treatment and co-digestion. *Journal of Material Cycles and Waste Management*, 18(3), 427–436. <https://doi.org/10.1007/s10163-016-0469-0>

- Chanakya, H. N., & Sreesha, M. (2012). Anaerobic retting of banana and arecanut wastes in a plug flow digester for recovery of fiber, biogas and compost. *Energy for Sustainable Development*, 16(2), 231–235. <https://doi.org/10.1016/j.esd.2012.01.003>
- Chang, N. B., & Pires, A. (2015). *Sustainable Solid Waste Management: A Systems Engineering Approach*. Institute of Electrical and Electronics Engineers Press, Hoboken: John Wiley & Sons. [https:// www. worldcat. org/title/ sustainable -solid- waste- management-a-systems-engineering-approach/oclc/890971741](https://www.worldcat.org/title/sustainable-solid-waste-management-a-systems-engineering-approach/oclc/890971741)
- Chanton, J. P., Powelson, D. K., & Green, R. B. (2009). Methane Oxidation in Landfill Cover Soils, is a 10% Default Value Reasonable? *Journal of Environmental Quality*, 38(2), 654–663. <https://doi.org/10.2134/jeq2008.0221>
- Chaturvedi, V., & Verma, P. (2013). An overview of key pretreatment processes employed for bioconversion of lignocellulosic biomass into biofuels and value added products. *3Biotech*, 3(5), 415–431. <https://doi.org/10.1007/s13205-013-0167-8>
- Chen, T., Shen, D., Jin, Y., Li, H., Yu, Z., Feng, H., Long Y., & Yin, J. (2017). Comprehensive evaluation of environ-economic benefits of anaerobic digestion technology in an integrated food waste-based methane plant using a fuzzy mathematical model. *Applied Energy*, 208, 666–677. <https://doi.org/10.1016/j.apenergy.2017.09.082>
- Cheng, S., Li, Z., Mang, H. P., Huba, E. M., Gao, R., & Wang, X. (2014). Development and application of prefabricated biogas digesters in developing countries. *Renewable and Sustainable Energy Reviews*, 34, 387–400. [https:// doi. org/ 0. 1016/j. ser. 2014. 03.035](https://doi.org/10.1016/j.ser.2014.03.035)
- Dang, Y., Sun, D., Woodard, T. L., Wang, L. Y., Nevin, K. P., & Holmes, D. E. (2017). Stimulation of the anaerobic digestion of the dry organic fraction of municipal solid waste (OFMSW) with carbon-based conductive materials. *Bioresource Technology*, 238, 30–38. <https://doi.org/10.1016/j.biortech.2017.04.021>
- Datta, R. (1981). Acidogenic fermentation of lignocellulose—acid yield and conversion of components. *Biotechnology and Bioengineering*, 23(9), 2167–2170. [https://doi.org /10.1002/bit.260230921](https://doi.org/10.1002/bit.260230921)
- Divya, D., Gopinath, L. R., & Christy, P. M. (2014). A review on current aspects and diverse prospects for enhancing biogas production in sustainable means. *Renewable and*

Sustainable Energy Reviews, 42, 690–699. <https://doi.org/10.1016/j.rser.2014.10.055>

Dotzauer, E., Patrizio, P., Leduc, S., Kraxner, F., & Chinese, D. (2015). Biomethane as transport fuel: A comparison with other biogas utilization pathways in northern Italy. *Applied Energy*, 157, 25–34. <https://doi.org/10.1016/j.apenergy.2015.07.074>

FAO/WHO. (2019). *General Standard For Contaminants And Toxins In Food And Feed CXS 193-1995*. http://www.fao.org/fao-who-codexalimentarius/sh-proxy/en/?lnk=1&url=https%253A%252F%252Fworkspace.fao.org%252Fsites%252Fcodex%252Fstandards%252FCXS%2B193-1995%252FCXS_193e.pdf

Feng, X. M., Karlsson, A., Svensson, B. H., & Bertilsson, S. (2010). Impact of trace element addition on biogas production from food industrial waste - Linking process to microbial communities. *Microbiology Ecology*, 74(1), 226–240. <https://doi.org/10.1111/j.1574-6941.2010.00932.x>

Fernandes, E. R. K., Marangoni, C., Souza, O., & Sellin, N. (2013). Thermochemical characterization of banana leaves as a potential energy source. *Energy Conversion and Management*, 75, 603–608. <https://doi.org/10.1016/j.enconman.2013.08.008>

Gebrezgabher, S. A., Meuwissen, M. P. M., Prins, B. A. M., & Lansink, A. G. J. M. O. (2010). Economic analysis of anaerobic digestion-A case of Green power biogas plant in the Netherlands. *Wageningen Journal of Life Sciences*, 57(2), 109–115. <https://doi.org/10.1016/j.njas.2009.07.006>

Girmay, Z., Gorems, W., Birhanu, G., & Zewdie, S. (2016). Growth and yield performance of *Pleurotus ostreatus* (Jacq. Fr.) Kumm (oyster mushroom) on different substrates. *Applied and Industrial Microbiology Express*, 6(1), 1–7. <https://doi.org/10.1186/s13568-016-0265-1>

Haaren, R., Van-Themelis, N. J., & Barlaz, M. (2010). Life cycle assessment comparison of windrow composting of yard wastes with use as alternative daily cover (ADC). *Waste Management*, 30(12), 2649–2656. <https://doi.org/10.1016/j.wasman.2010.06.007>

Habagil, M., Keucken, A., & Horváth, I. S. (2020). Biogas production from food residues: The role of trace metals and co-digestion with primary sludge. *Environments*, 7(6), 8–10.

<https://doi.org/10.3390/environments7060042>

- Hagos, K., Zong, J., Li, D., Liu, C., & Lu, X. (2016). Anaerobic co-digestion process for biogas production: Progress, challenges and perspectives. *Renewable and Sustainable Energy Reviews*, 76, 1485–1496. <https://doi.org/10.1016/j.rser.2016.11.184>
- Hallaji, S. M., Kuroshkarim, M., & Moussavi, S. P. (2019). Enhancing methane production using anaerobic co-digestion of waste activated sludge with combined fruit waste and cheese whey. *BioMedical Central Biotechnology*, 19(1), 1–10. <https://doi.org/10.1186/s12896-019-0513-y>
- Hao, X., Liu, R., & Huang, X. (2015). Evaluation of the potential for operating carbon neutral wastewater treatment plant in China. *Water Research*, 87, 424–431. <https://doi.org/10.1016/j.watres.2015.05.050>
- Hong, J., Li, X., & Zhaojie, C. (2010). Life cycle assessment of four municipal solid waste management scenarios in China. *Waste Management*, 30(11), 2362–2369. <https://doi.org/10.1016/j.wasman.2010.03.038>
- Hoornweg, D., & Bhada-Tata, P. (2012). *What a Waste: A Global Review of Solid Waste Management*. Washington, DC: World Bank. <https://openknowledge.worldbank.org/handle/10986/17388>
- Igoni, A. H., Abowei, M. F. N., Ayotamuno, M. J., & Eze, C. L. (2008). Comparative evaluation of batch and continuous anaerobic digesters in biogas production from municipal solid waste using mathematical models. *Agricultural Engineering International Journal*, 10, 1–12. <https://cigrjournal.org/index.php/Ejournal/article/view/1160>
- Islam, M. R., Rahman, S. M. E., Rahman, D. H. O., & Ra, C. S. (2010). The effects of biogas slurry on the production and quality of maize fodder. *Turkish Journal of Agriculture and Forestry*, 34, 91–99. <https://doi.org/10.3906/tar-0902-44>
- ISO14040. (2006). *Environmental Management: Life Cycle Assessment, Principles and Framework*. Geneva: International Organization for Standardization. <https://www.iso.org/standard/37456.html>
- Izumi, K., Okishio, Y. K., Nagao, N., Niwa, C., Yamamoto, S., & Toda, T. (2010). Effects of

particle size on anaerobic digestion of food waste. *International Biodeterioration and Biodegradation*, 64, 601–608. <https://doi.org/10.1016/j.ibiod.2010.06.013>

Jena, S. P., Mishra, S., Acharya, S. K., & Mishra, S. K. (2017). An experimental approach to produce biogas from semi dried banana leaves. *Sustainable Energy Technologies and Assessments*, 19, 173–178. <https://doi.org/10.1016/j.seta.2017.01.001>

Jena, S. P., Mohanty, U. K., & Mahapatra, S. (2020). Anaerobic digestion of semi-dried banana leaves in sewage water under the influence of certain additives. *Materials Today: Proceedings*, 33(8), 4988-4992. <https://doi.org/10.1016/j.matpr.2020.02.830>

Jenicek, P., Bartacek, J., Kutil, J., Zabranska, J., & Dohanyos, M. (2012). Potentials and limits of anaerobic digestion of sewage sludge: Energy self-sufficient municipal wastewater treatment plant? *Water Science and Technology*, 66(6), 1277–1281. <https://doi.org/10.2166/wst.2012.317>

Ji, Z. G. (2017). Water quality and eutrophication. In J. Zhen-Gang (Ed.), *Hydrodynamics and Water Quality* (pp. 161–271). <https://doi.org/10.1002/9781119371946.ch5>

Jiang, J. G., Zhang, Y. J., Li, K. M., Wang, Q., Gong, C. X., & Li, M. L. (2013). Volatile fatty acids production from food waste: Effects of pH, temperature, and organic loading rate. *Bioresource Technology*, 143, 525–530. <https://doi.org/10.1016/j.biortech.2013.06.025>

Kamdem, I., Hiligsmann, S., Vanderghem, C., Bilik, I., Paquot, M., & Thonart, P. (2013). Comparative biochemical analysis during the anaerobic digestion of lignocellulosic biomass from six morphological parts of Williams Cavendish banana (Triploid Musa AAA group) plants. *World Journal of Microbiology and Biotechnology*, 29(12), 2259–2270. <https://doi.org/10.1007/s11274-013-1392-3>

Karak, T., Bhagat, R. M., & Bhattacharyya, P. (2012). Municipal solid waste generation, composition, and management: The world scenario. *Environmental Science and Technology*, 42, 1509–1630. <https://doi.org/10.1080/10643389.2011.569871>

Kassuwi, S. A. A., Mshandete, A. M., & Kivaisi, A. K. (2012). Anaerobic co-digestion of biological pre-treated Nile perch fish solid waste with vegetable fraction of market solid waste. *Journal of Agricultural & Biological Science*, 7(12), 1016–1031.

<http://citeseerx.ist.psu.edu/viewdoc/download?doi=10.1.1.1046.7402&rep=rep1&type=pdf>

- Kaza, S, Bhada-Tata P. (2018). *Decision Maker's Guides for Solid Waste Management Technologies*. Washington, DC: World Bank; 2018. <https://openknowledge.worldbank.org/handle/10986/31694> License: CC BY 3.0 IGO
- Kazuva, E., & Zhang, J. Q. (2019). Analyzing municipal solid waste treatment scenarios in rapidly urbanizing cities in developing countries: The case of Dar es Salaam, Tanzania. *International Journal of Environmental Research and Public Health*, 16, 1-21. <https://doi.org/10.3390/ijerph16112035>
- Kennedy, J. (2009). Bananas and people in the homeland of genus *Musa*: Not just pretty fruit. *Ethnobotany Research and Applications*, 7, 179–198. <https://doi.org/10.17348/era.7.0.179-197>
- Khandelwal, H., Thalla, A. K., Kumar, S., & Kumar, R. (2019). Life cycle assessment of municipal solid waste management options for India. *Bioresource Technology*, 288, 1-7. <https://doi.org/10.1016/j.biortech.2019.121515>
- Khoo, H. H., Lim, T. Z., & Tan, R. B. H. (2010). Food waste conversion options in Singapore: Environmental impacts based on an life cycle assessment perspective. *Science of the Total Environment*, 408(6), 1367–1373. <https://doi.org/10.016/j.scitotenv.2009.10.072>
- Koszel, M., & Lorencowicz, E. (2015). Agricultural use of biogas digestate as a replacement fertilizers. *Agriculture and Agricultural Science Procedia*, 7, 119–124. <https://doi.org/10.1016/j.aaspro.2015.12.004>
- Kothari, R., Kumar, V., Pawar, N. L., & Tyagi, V. V. (2014). Municipal solid-waste management strategies for renewable energy options. In L. J. Wang (Ed), *Sustainable bioenergy production (pp. 263–83)*. Boca Raton: CRC Press. <https://doi.org/10.1201/b16764>
- Krishna, D., & Kalamdhad, A. S. (2014). Pre-treatment and anaerobic digestion of food waste for high rate methane production. *Journal of Environmental Chemical Engineering*, 2(3), 1821–1830. <https://doi.org/10.1016/j.jece.2014.07.024>
- Kucharska, K., Rybarczyk, P., Hołowacz, I., Łukajtis, R., Glinka, M., & Kamiński, M. (2018).

Pretreatment of lignocellulosic materials as substrates for fermentation processes. *Molecules*, 23(11), 1–32. <https://doi.org/10.3390/molecules23112937>

- Kumar, A. K., & Sharma, S. (2017). Recent updates on different methods of pretreatment of lignocellulosic feedstocks. *Bioresources and Bioprocessing*, 4(1), 1-19. <https://doi.org/10.1186/s40643-017-0137-9>
- Kumar, A., & Samadder, S. R. (2017). A review on technological options of waste to energy for effective management of municipal solid waste. *Waste Management*, 69, 407–422. <https://doi.org/10.1016/j.wasman.2017.08.046>
- Laks, R. (2017). *The Potential For Electricity Generation From Biogas in South Africa: A Potential Study As Part Of The BAPEPSA Project*. <https://publicaties.ecn.nl/PdfFetch.aspx?nr=ECN-E--17-001>
- Lee, Y., Lee, S. H., & Park, H. D. (2016). Enrichment of specific electro-active microorganisms and enhancement of methane production by adding granular activated carbon in anaerobic reactors. *Bioresource Technology*, 205, 205–212. <https://doi.org/10.1016/j.biortech.2016.01.054>
- Lee, U., Han, J., & Wang, M. (2017). Evaluation of landfill gas emissions from municipal solid waste landfills for the life-cycle analysis of waste-to-energy pathways. *Journal of Cleaner Production*, 166, 335–342. <https://doi.org/10.1016/j.jclepro.2017.08.016>
- Liu, F., Rotaru, A. E., Shrestha, P. M., Malvankar, N. S., Nevin, K. P., & Lovley, D. R. (2012). Promoting direct interspecies electron transfer with activated carbon. *Energy and Environmental Science*, 5(10), 8982–8989. <https://doi.org/10.1039/c2ee22459c>
- Luo, C., Lü, F., Shao, L., & He, P. (2015). Application of eco-compatible biochar in anaerobic digestion to relieve acid stress and promote the selective colonization of functional microbes. *Water Research*, 68, 710–718. <https://doi.org/10.1016/j.watres.014.10.52>
- Maalouf, A., & El-Fadel, M. (2017). Effect of a food waste disposer policy on solid waste and wastewater management with economic implications of environmental externalities. *Waste Management*, 69, 455–462. <https://doi.org/10.1016/j.wasman.2017.08.008>
- Mackul'ak, T., Prousek, J., Švorc, L., & Drtil, M. (2012). Increase of biogas production from

pretreated hay and leaves using wood-rotting fungi. *Chemical Papers*, 66(7), 649–653. <https://doi.org/10.2478/s11696-012-0171-1>

- Maharaj, B. C., Mattei, M. R., Frunzo, L., Van Hullebusch, E. D., & Esposito, G. (2021). A general framework to model the fate of trace elements in anaerobic digestion environments. *Scientific Reports*, 11(1), 1–19. <https://doi.org/10.1038/s41598-021-85403-2>
- Maragkaki, A. E., Fountoulakis, M., Kyriakou, A., Lasaridi, K., & Manios, T. (2018). Boosting biogas production from sewage sludge by adding small amount of agro-industrial by-products and food waste residues. *Waste Management*, 71, 605–611. <https://doi.org/10.1016/j.wasman.2017.04.024>
- Maryana, R., Ma'rifatun, D., Wheni, I. A., Satriyo K. W., & Rizal, W. A. (2014). Alkaline pretreatment on sugarcane bagasse for bioethanol production. *Energy Procedia*, 47, 250–254. <https://doi.org/10.1016/j.egypro.2014.01.221>
- Mattioli, A., Gatti, G. B., Mattuzzi, G. P., Cecchi, F., & Bolzonella, D. (2017). Co-digestion of the organic fraction of municipal solid waste and sludge improves the energy balance of wastewater treatment plants: Rovereto case study. *Renewable Energy*, 113, 980-988 <https://doi.org/10.1016/j.renene.2017.06.079>
- Metri, Y., Warly, L., & Suyit, M. (2018). Biodegradation of lignin by white rot fungi (*Pleurotus ostreatus*) to decrease the fibre components in the palm midrib. *Pakistan Journal of Nutrition*, 17(2), 71–75. <https://doi.org/10.3923/pjn.2018.71.75>
- Miezah, K., Obiri-Danso, K., Kádár, Z., Fei-Baffoe, B., & Mensah, M. Y. (2015). Municipal solid waste characterization and quantification as a measure towards effective waste management in Ghana. *Waste Management*, 46, 15–27. <https://doi.org/10.1016/j.wasman.2015.09.009>
- Mir, M. A., Hussain, A., & Verma, C. (2016). Design considerations and operational performance of anaerobic digester. *Cogent Engineering*, 3, 1-20. <https://doi.org/10.1080/23311916.2016.1181696>
- Mishra, S., Singh, P. K., Dash, S., & Pattnaik, R. (2018). Microbial pretreatment of lignocellulosic biomass for enhanced biomethanation and waste management.

3Biotech, 8, 458. <https://doi.org/10.1007/s13205-018-1480-z>

- Mitchell, R., & Gu, J. (2010). *Environmental Microbiology*. John Wiley & Sons, Inc., Hoboken, New Jersey. [https:// www. amazon. com/ Environmental –Microbiology- Ralph-Mitchell/ dp/047017790X](https://www.amazon.com/Environmental-Microbiology-Ralph-Mitchell/dp/047017790X)
- Mmerekki, D., Baldwin, A., & Li, B. (2016). A comparative analysis of solid waste management in developed, developing and lesser developed countries. *Environmental Technology Reviews*, 5, 120–141. [https:// doi. org/ 10. 1080/ 21622515.2016.1259357](https://doi.org/10.1080/21622515.2016.1259357)
- Mohee, R., Mauthoor, S., Bundhoo, Z. M. A., Somaroo, G., Soobhany, N., & Gunasee, S. (2015). Current status of solid waste management in small island developing states. *Waste Management*, 43, 539–549. <https://doi.org/10.1016/j.wasman.2015.06.012>
- Mota, V. T., Santos, F. S., Araújo, T. A., & Amaral, M. C. S. (2015). Evaluation of titration methods for volatile fatty acids measurement: Effect of the bicarbonate interference and feasibility for the monitoring of anaerobic reactors. *Water Practice and Technology*, 10(3), 486–495. <https://doi.org/10.2166/wpt.2015.05>
- Mukhuba, M., Roopnarain, A., Adeleke, R., Moeletsi, M., & Makofane, R. (2018). Comparative assessment of bio-fertiliser quality of cow dung and anaerobic digestion effluent. *Cogent Food and Agriculture*, 4, 1-11. <https://doi.org/10.1080/23311932.2018.1435019>
- Mustafa, A. M., Poulsen, T. G., & Sheng, K. (2016). Fungal pretreatment of rice straw with *Pleurotus ostreatus* and *Trichoderma reesei* to enhance methane production under solid-state anaerobic digestion. *Applied Energy*, 180, 661–671. [https://doi.org/10.1016/j. apenergy. 2016.07.135](https://doi.org/10.1016/j.apenergy.2016.07.135)
- Muthangya, M., Mshandete, A. M., & Kivaisi, A. K. (2009). Enhancement of Anaerobic Digestion of Sisal Leaf Decortication Residues By Biological Pre-Treatment. *Journal of Agricultural and Biological Science*, 4(4), 66–73.
- Mwalongo, D., & Mohammed, N. K. (2013). Determination of essential and toxic elements in clay soil commonly consumed by pregnant women in Tanzania. *Radiation Physics and Chemistry*, 91, 15–18. <https://doi.org/10.1016/j.radphyschem.2013.06.002>

- Naami, A. A. (2017). *Techno-economic Feasibility Study of a Biogas Plant for Treating Food Waste Collected from Households in Kartamantul Region [Master of Science thesis of KTH School of Industrial Engineering and Management]*. <http://www.diva-portal.se/smash/get/diva2:1209090/FULLTEXT02.pdf>
- Nabegu, A. B. (2010). An Analysis of Municipal Solid Waste in Kano Metropolis, Nigeria. *Journal of Human Ecology*, 31(2), 111–119. <https://doi.org/10.1080/09709274.2010.11906301>
- Nghiem, L. D., Koch, K., Bolzonella, D., & Drewes, J. E. (2017). Full scale co-digestion of wastewater sludge and food waste: Bottlenecks and possibilities. *Renewable and Sustainable Energy Reviews*, 72, 354–362. <https://doi.org/10.1016/j.rser.2017.01.062>
- Nkoa, R. (2014). Agricultural benefits and environmental risks of soil fertilization with anaerobic digestates. *Agronomy for Sustainable Development*, 34(2), 473–492. <https://doi.org/10.1007/s13593-013-0196-z>
- Nolan, T., Troy, S. M., Healy, M. G., Kwapinski, W., Leahy, J. J., & Lawlor, P. G. (2011). Characterization of compost produced from separated pig manure and a variety of bulking agents at low initial C/N ratios. *Bioresource Technology*, 102(14), 7131–7138. <https://doi.org/10.1016/j.biortech.2011.04.066>
- Odedina, M. J., Charnnok, B., Saritpongteeraka, K., & Chairapat, S. (2017). Effects of size and thermophilic pre-hydrolysis of banana peel during anaerobic digestion, and biomethanation potential of key tropical fruit wastes. *Waste Management*, 68, 128–138. <https://doi.org/10.1016/j.wasman.2017.07.003>
- Okot-Okumu, J. (2012). *Solid Waste Management in African Cities – East Africa, Waste Management - An Integrated Vision*. IntechOpen. <https://doi.org/10.5772/50241>
- Omari, A. M., Kichonge, B. N., John, G. R., Njau, K. N., & Mtui, P. L. (2014). Potential of municipal solid waste, as renewable energy source: A case study of Arusha, Tanzania. *International Journal of Renewable Energy Technology Research*, 3, 1–9.
- Omari, A. M., (2015). Characterization of Municipal solid waste for energy recovery. *Journal of Multidisciplinary Engineering Science and Technology*, 2(1), 3159–40. <https://doi.org/10.12691/ajer-3-2-3>

- Oumarou, M. B., Dauda, M., Abdulrahim, A. T., & Abubakar, A. B. (2012). Characterization and Generation of Municipal Solid Waste in North Central Nigeria. *International Journal of Modern Engineering Research*, 2(5), 3669–3672.
- Owaid, M. N., Abed, I. A., & Al-Saedi, S. S. S. (2017). Applicable properties of the bio-fertilizer spent mushroom substrate in organic systems as a byproduct from the cultivation of *Pleurotus* spp. *Information Processing in Agriculture*, 4(1), 78–82. <https://doi.org/10.1016/j.inpa.2017.01.001>
- Oyoo, R., Leemans, R., & Mol, A. P. J. (2014). Comparison of environmental performance for different waste management scenarios in East Africa: The case of Kampala City, Uganda. *Habitat International*, 44, 349–357. <https://doi.org/10.1016/j.habitatint.2014.07.012>
- Padam, B. S., Tin, H. S., Chye, F. Y., & Abdullah, M. I. (2014). Banana by-products: An under-utilized renewable food biomass with great potential. *Journal of Food Science and Technology*, 51(12), 3527–3545. <https://doi.org/10.1007/s13197-012-0861-2>
- Palanivel, T. M., & Sulaiman, H. (2014). Generation and Composition of Municipal Solid Waste (MSW) in Muscat, Sultanate of Oman. *Procedia*, 10, 96–102. <https://doi.org/10.1016/j.apcbee.2014.10.024>
- Patinvoh, R. J., Osadolor, O. A., Sárvári H. I., & Taherzadeh, M. J. (2017). Cost effective dry anaerobic digestion in textile bioreactors: Experimental and economic evaluation. *Bioresource Technology*, 245(Part A), 549–559. <https://doi.org/10.1016/j.biortech.2017.08.081>
- Patterson, T., Esteves, S., Dinsdale, R., Guwy, A., & Maddy, J. (2013). Life cycle assessment of biohydrogen and biomethane production and utilisation as a vehicle fuel. *Bioresource Technology*, 131, 235–245. <https://doi.org/10.1016/j.biortech.2012.12.109>
- Pavan, P., Fatone, F., Cecchi, F., Bolzonella, D., & Cavinato, C. (2013). Mesophilic and thermophilic anaerobic co-digestion of waste activated sludge and source sorted biowaste in pilot- and full-scale reactors. *Renewable Energy*, 55, 260–265. <https://doi.org/10.1016/j.renene.2012.12.044>
- Pavi, S., Kramer, L. E., Gomes, L. P., & Miranda, L. A. S. (2017). Biogas production from

co-digestion of organic fraction of municipal solid waste and fruit and vegetable waste. *Bioresource Technology*, 228, 362–367. <https://doi.org/10.1016/j.biortech.2017.01.003>

- Pires, A., Chang, N. B., & Martinho, G. (2011). Reliability-based life cycle assessment for future solid waste management alternatives in Portugal. *International Journal of Life Cycle Assessment*, 16(4), 316–337. <https://doi.org/10.1007/s11367-011-0269-7>
- Pognani, M., Barrena, R., Font, X., & Sánchez, A. (2012). Bioresource Technology Effect of freezing on the conservation of the biological activity of organic solid wastes. *Bioresource Technology*, 104, 832–836. <https://doi.org/10.1016/j.biortech.2011.11.097>
- Raimi, A., Adeleke, R., & Roopnarain, A. (2017). Soil fertility challenges and biofertiliser as a viable alternative for increasing smallholder farmer crop productivity in sub-Saharan Africa. *Cogent Food and Agriculture*, 3(1), 1-26. <https://doi.org/10.1080/23311932.2017.1400933>
- Rajaeifar, M. A., Tabatabaei, M., & Ghanavati, H. (2015). Data supporting the comparative life cycle assessment of different municipal solid waste management scenarios. *Data in Brief*, 3, 189–194. <https://doi.org/10.1016/j.dib.2015.02.020>
- Rajaeifar, M. A., Tabatabaei, M., Ghanavati, H., Khoshnevisan, B., & Rafiee, S. (2015). Comparative life cycle assessment of different municipal solid waste management scenarios in Iran. *Renewable and Sustainable Energy Reviews*, 51, 886–898. <https://doi.org/10.1016/j.rser.2015.06.037>
- Rajagopal, R., Massé, D. I., & Singh, G. (2013). A critical review on inhibition of anaerobic digestion process by excess ammonia. *Bioresource Technology*, 143, 632–641. <https://doi.org/10.1016/j.biortech.2013.06.030>
- Rashad, F. M., Saleh, W. D., & Moselhy, M. A. (2010). Bioresource Technology Bioconversion of rice straw and certain agro-industrial wastes to amendments for organic farming systems, Composting, quality, stability and maturity indices. *Bioresource Technology*, 101(15), 5952–5960. <https://doi.org/10.1016/j.biortech.2010.02.103>
- Rasi, S., Veijanen, A., & Rintala, J. (2007). Trace compounds of biogas from different biogas production plants. *Energy*, 32(8), 1375–1380. <https://doi.org/10.1016/j.energy.2006.10.003>

- Raven, R. P. J. M., & Geels, F. W. (2010). Technovation Socio-cognitive evolution in niche development: Comparative analysis of biogas development in Denmark and the Netherlands (1973 – 2004). *Technovation*, 30(2), 87–99. <https://doi.org/10.1016/j.technovation.2009.08.006>
- Raven, R. P. J. M., & Gregersen, K. H. (2007). Biogas plants in Denmark: Successes and setbacks Biogas plants in Denmark: Successes and setbacks. *Renewable and Sustainable Energy Reviews*, 11, 116–132. <https://doi.org/10.1016/j.rser.2004.12.002>
- Raymond, P., Mshandete, M. A., & Kivaisi, A. K. (2013). Cultivation of Oyster Mushroom (Pleurotus HK-37) On Solid Sisal Waste Fractions Supplemented With Cow Dung Manure. *Journal of Biology and Life Science*, 4(1), 273-286. <https://doi.org/10.5296/jbls.v4i1.2975>
- Ricker-Gilbert, J., & Jayne, T. S. (2017). Estimating the Enduring Effects of Fertiliser Subsidies on Commercial Fertiliser Demand and Maize Production: Panel Data Evidence from Malawi. *Journal of Agricultural Economics*, 68(1), 70–97. <https://doi.org/10.1111/1477-9552.12161>
- Rodríguez-Couto, S. (2017). Industrial and environmental applications of white-rot fungi. *Mycosphere*, 8(3), 456–466. <https://doi.org/10.5943/mycosphere/8/3/7>
- Rouches, E., Herpoël-Gimbert, I., Steyer, J. P., & Carrere, H. (2016). Improvement of anaerobic degradation by white-rot fungi pretreatment of lignocellulosic biomass. *Renewable and Sustainable Energy Reviews*, 59, 179–198. <https://doi.org/10.1016/j.rser.2015.12.317>
- Sambusiti, C., Monlau, F., Ficara, E., Carrère, H., & Malpei, F. (2013). A comparison of different pre-treatments to increase methane production from two agricultural substrates. *Applied Energy*, 104, 62–70. <https://doi.org/10.1016/j.apenergy.2012.10.060>
- Sari, F. P., & Budiyo, B. (2014). Enhanced biogas production from rice straw with various pretreatment. *Waste Technology*, 2(1), 17-25. <https://doi.org/10.12777/wastech.2.1.17-25>
- Semiyaga, S., Okure, M. A. E., Niwagaba, C. B., Katukiza, A. Y., & Kansiime, F. (2015).

Decentralized options for faecal sludge management in urban slum areas of Sub-Saharan Africa: A review of technologies, practices and end-uses. *Resources, Conservation and Recycling*, 104,109–119.<https://doi.org/10.1016/j.resconrec.2015.09.001>

Sharma, B. K., & Chandel, M. K. (2017). Life cycle assessment of potential municipal solid waste management strategies for Mumbai, India. *Waste Management and Research*, 35(1), 79–91. <https://doi.org/10.1177/0734242X16675683>

Shen, Y., Linville, J. L., Ignacio-de Leon, P. A. A., Schoene, R. P., & Urgun-Demirtas, M. (2016). Towards a sustainable paradigm of waste-to-energy process: Enhanced anaerobic digestion of sludge with woody biochar. *Journal of Cleaner Production*, 135, 1054–1064. <https://doi.org/10.1016/j.jclepro.2016.06.144>

Shen, Y., Linville, J. L., Urgun-demirtas, M., Mintz, M. M., & Snyder, S. W. (2015). An overview of biogas production and utilization at full-scale wastewater treatment plants (WWTPs) in the United States: Challenges and opportunities towards energy-neutral WWTPs. *Renewable and Sustainable Energy Reviews*, 50, 346–362. <https://doi.org/10.1016/j.rser.2015.04.129>

Shrestha, S., Fonoll, X., Khanal, S. K., & Raskin, L. (2017). Biological strategies for enhanced hydrolysis of lignocellulosic biomass during anaerobic digestion: Current status and future perspectives. *Bioresource Technology*, 245, 1245–1257. <https://doi.org/10.1016/j.biortech.2017.08.089>

Sorensen, B. (2010). *Renewable Energy: Physics, Engineering, Environmental Impacts, Economics and Planning*. Academic Press. <https://www.amazon.com/Renewable-Energy-Engineering-Environmental-Economics/dp/0123750253>

Sun, C., Cao, W., Banks, C. J., Heaven, S., & Liu, R. (2016). Biogas production from undiluted chicken manure and maize silage: A study of ammonia inhibition in high solids anaerobic digestion. *Bioresource Technology*, 218, 1215–1223. <https://doi.org/10.1016/j.biortech.2016.07.082>

Surendra, K. C., Takara, D., Hashimoto, A. G., & Khanal, S. K. (2014). Biogas as a sustainable energy source for developing countries: Opportunities and challenges. *Renewable and*

Sustainable Energy Reviews, 31, 846–859. <https://doi.org/10.1016/j.rser.2013.12.015>

Tan, S. T., Ho, W. S., Hashim, H., Lee, C. T., Taib, M. R., & Ho, C. S. (2015). Energy, economic and environmental (3E) analysis of waste-to-energy (WTE) strategies for municipal solid waste (MSW) management in Malaysia. *Energy Conversion and Management*, 102, 111–120. <https://doi.org/10.1016/j.enconman.2015.02.010>

Temu, S., Moshi, A., Nges, I., Mshandete, A., Kivaisi, A., & Mattiasson, B. (2016). Mixed palm oil waste utilization through Integrated mushroom and biogas production. *British Biotechnology Journal*, 11(4), 1–12. <https://doi.org/10.9734/bbj/2016/23385>

Tesfaw, A., Tadesse, A., & Kiros, G. (2015). Optimization of oyster (*Pleurotus ostreatus*) mushroom cultivation using locally available substrates and materials in Debre Berhan, Ethiopia. *Journal of Applied Biology & Biotechnology*. <https://doi.org/10.7324/jabb.2015.3103>

Thomsen, S. T., Londoño, J. E. G., Ambye-Jensen, M., Heiske, S., Kádár, Z., & Meyer, A. S. (2016). Combination of ensiling and fungal delignification as effective wheat straw pretreatment. *Biotechnology for Biofuels*, 9(16), 1-10. <https://doi.org/10.1186/s13068-016-0437-x>

Timma, L., Dace, E., & Knudsen, M. T. (2020). Temporal Aspects in Emission Accounting: Case Study of Agriculture Sector. *Energies*, 13(4), 1-21. <https://doi.org/10.3390/en13040800>

Torrijos, M. (2016). State of Development of Biogas Production in Europe. *Procedia Environmental Sciences*, 35, 881–889. <https://doi.org/10.1016/j.proenv.2016.07.043>

Tumwesige, V., Fulford, D., & Davidson, G. C. (2014). Biogas appliances in Sub-Saharan Africa. *Biomass and Bioenergy*, 70, 40–50. <https://doi.org/10.1016/j.biombioe.2014.02.017>

United Nations, Department of Economic and Social Affairs, Population Division (2017). *World Population Prospects: The 2017 Revision, Key Findings and Advance Tables. Working Paper No. ESA/P/WP/248*. https://population.un.org/wpp/publications/files/wpp2017_keyfindings.pdf

- Vazifekhoran, A. H., Shin, S. G., & Triolo, J. M. (2018). Use of tannery wastewater as an alternative substrate and a pre-treatment medium for biogas production. *Bioresource Technology*, 258, 64–69. <https://doi.org/10.1016/j.biortech.2018.02.116>
- Vieira, F. R., & de Andrade, M. C. N. (2016). Optimization of substrate preparation for oyster mushroom (*Pleurotus ostreatus*) cultivation by studying different raw materials and substrate preparation conditions (composting: phases I and II). *World Journal of Microbiology and Biotechnology*, 32(11), 1-9. <https://doi.org/10.1007/s11274-016-2152-y>
- Vögeli, Y., Lohri, C. R., Gallardo, A., Diener, S., & Zurbrügg, C. (2014). *Anaerobic Digestion of Biowaste in Developing Countries - Practical Information and Case Studies*. Eawag, Dübendorf, Switzerland. <https://www.susana.org/en/knowledge-hub/resources-and-publications/library/details/2999>
- Wagner, A. O., Lackner, N., Mutschlechner, M., Prem, E. M., Markt, R., & Illmer, P. (2018). Biological pretreatment strategies for second-generation lignocellulosic resources to enhance biogas production. *Energies*, 11(7), 1797. <https://doi.org/10.3390/en11071797>
- Wan, C., & Li, Y. (2012). Fungal pretreatment of lignocellulosic biomass. *Biotechnology Advances*, 30(6), 1447–1457. <https://doi.org/10.1016/j.biotechadv.2012.03.003>
- Wang, K., Yin, J., Shen, D., & Li, N. (2014). Anaerobic digestion of food waste for volatile fatty acids (VFAs) production with different types of inoculum: Effect of pH. *Bioresource Technology*, 161, 395–401. <https://doi.org/10.1016/j.biortech.2014.03.088>
- Wei, Q. Y., Zhang, W. Q., Guo, J. B., Wu, S. B., Tan, T. W., Wang, F., & Dong, R. J. (2014). Performance and kinetic evaluation of a semi-continuously fed anaerobic digester treating food waste: Effect of trace elements on the digester recovery and stability. *Chemosphere*, 117, 477–485. <https://doi.org/10.1016/j.chemosphere.2014.08.060>
- Wei, Q., Zhang, W., Guo, J., Wu, S., Tan, T., Wang, F., & Dong, R. (2014). Performance and kinetic evaluation of a semi-continuously fed anaerobic digester treating food waste: Effect of trace elements on the digester recovery and stability. *Chemosphere*, 117(1), 477–485. <https://doi.org/10.1016/j.chemosphere.2014.08.060>

- Widyarani, V. Y., Sriwuryandari, L., Priantoro, E. A., Sembiring, T., & Sintawardani, N. (2018). *Influence of pH on biogas production in a batch anaerobic process of tofu wastewater*. Conference Series: Earth and Environmental Science, 160, 1-7. <https://doi.org/10.1088/1755-1315/160/1/012014>
- Woon, K. S., Lo, I. M. C., Chiu, S. L. H., & Yan, D. Y. S. (2016). Environmental assessment of food waste valorization in producing biogas for various types of energy use based on life cycle assessment approach. *Waste Management*, 50, 290–299. <https://doi.org/10.1016/j.wasman.2016.02.022>
- World Heritage Watch. (2019). *Heritage Dammed .Water Infrastructure Impacts on World Heritage Sites and Free Flowing Rivers*. http://www.transrivers.org/pdf/20190430_Heritage_Dammed_Report_Draft.pdf
- Wu, X., Yao, W., Zhu, J., & Miller, C. (2010). Bioresource Technology Biogas and CH₄ productivity by co-digesting swine manure with three crop residues as an external carbon source. *Bioresource Technology*, 101(11), 4042–4047. <https://doi.org/10.1016/j.biortech.2010.01.052>
- Xie, S., Hai, F. I., Zhan, X., Guo, W., Ngo, H. H., Price, W. E., & Nghiem, L. D. (2016). Anaerobic co-digestion: A critical review of mathematical modelling for performance optimization. *Bioresource Technology*, 222, 498-512. <https://doi.org/10.1016/j.biortech.2016.10.015>
- Xu, S., Han, R., Zhang, Y., He, C., & Liu, H. (2018). Differentiated stimulating effects of activated carbon on methanogenic degradation of acetate, propionate and butyrate. *Waste Management*, 76, 394–403. <https://doi.org/10.1016/j.wasman.2018.03.037>
- Xu, Z., Zhao, M., Miao, H., Huang, Z., Gao, S., & Ruan, W. (2014). In situ volatile fatty acids influence biogas generation from kitchen wastes by anaerobic digestion. *Bioresource Technology*, 163, 186–192. <https://doi.org/10.1016/j.biortech.2014.04.037>
- Yang, W. J., Guo, F. L., & Wan, Z. J. (2013). Yield and size of oyster mushroom grown on rice/wheat straw basal substrate supplemented with cotton seed hull. *Saudi Journal of Biological Sciences*, 20(4), 333–338. <https://doi.org/10.1016/j.sjbs.2013.02.006>
- Ye, J. Q., Li, D., Sun, Y. M., Wang, G. H., Yuan, Z. H., Zhen, F., & Wang, Y. (2013). Improved

biogas production from rice straw by co-digestion with kitchen waste and pig manure. *Waste Management*, 33, 2653–2658. <https://doi.org/10.1016/j.wasman.2013.05.014>

- You, Z., Zhang, S., Kim, H., Chiang, P. C., Sun, Y., Guo, Z., & Xu, H. (2018). Effects of corn stover pretreated with NaOH and CaO on anaerobic co-digestion of swine manure and corn stover. *Applied Sciences*, 9(1), 1-12. <https://doi.org/10.3390/app9010123>
- Yu, X., Zhang, S., Liao, X., & Qi, X. (2018). Elimination and Choice Expressing Reality (ELECTRE) methods in prioritized Multiple Criteria Decision Making environment. *Information Sciences*, 424, 301–316. <https://doi.org/10.1016/j.ins.2017.09.061>
- Zakil, F. A., Sueb, M. S. M., & Isha, R. (2019). Growth and yield performance of *Pleurotus ostreatus* on various agro-industrial wastes in Malaysia. *Astronomy and Physics Conference Proceedings*, 2155, 1-7 <https://doi.org/10.1063/1.5125559>
- Zhang, A. L., Shen, J., & Ni, Y. H. (2015). Anaerobic digestion for use in the pulp and paper industry and other sectors: An introductory mini-review. *BioResources*, 10, 8750–8769. doi: 10.15376/biores.10.4.Zhang
- Zhang, C., Li, J., Liu, C., Liu, X., Wang, J., Li, S., Fan, G., & Zhang, L. (2013). Alkaline pretreatment for enhancement of biogas production from banana stem and swine manure by anaerobic codigestion. *Bioresource Technology*, 149, 353–358. <https://doi.org/10.1016/j.biortech.2013.09.070>
- Zhang, C., Su, H., Baeyens, J., & Tan, T. (2014). Reviewing the anaerobic digestion of food waste for biogas production. *Renewable and Sustainable Energy Reviews*, 38, 383–392. <https://doi.org/10.1016/j.rser.2014.05.038>
- Zhang, C., Xiao, G., Peng, L., Su, H., & Tan, T. (2013). The anaerobic co-digestion of food waste and cattle manure. *Bioresource Technology*, 129, 170–176. <https://doi.org/10.1016/j.biortech.2012.10.138>
- Zhang, K., Pei, Z., & Wang, D. (2016). Organic solvent pretreatment of lignocellulosic biomass for biofuels and biochemical. *Bioresource Technology*, 199, 21–33. <https://doi.org/10.1016/j.biortech.2015.08.102>

- Zhang, D. Q., Keat, T. S., & Gersberg, R. M. (2010). A comparison of municipal solid waste management in Berlin and Singapore. *Waste Management*, 30, 921–933. <https://doi.org/10.1016/j.wasman.2009.11.017>
- Zhang, L., & Jahng, D. (2012a). Long-term anaerobic digestion of food waste stabilized by trace elements. *Waste Management*, 32(8), 1509–1515. <https://doi.org/10.1016/j.wasman.2012.03.015>
- Zhang, L., & Jahng, D. K. (2012b). Long-term anaerobic digestion of food waste stabilized by trace elements. *Waste Management*, 32, 1509–1515. <https://doi.org/10.1016/j.wasman.2012.03.015>
- Zhang, L., Lee, Y., & Jahng, D. (2011). Anaerobic co-digestion of food waste and piggery wastewater: Focusing on the role of trace elements. *Bioresource Technology*, 102(8), 5048–5059. <https://doi.org/10.1016/j.biortech.2011.01.082>
- Zhang, W. Q., Wu, S. B., Guo, J. B., Zhou, J., & Dong, R. J. (2015). Performance and kinetic evaluation of semi-continuously fed anaerobic digesters treating food waste: role of trace elements. *Bioresource Technology*, 178, 297–305. <https://doi.org/10.1016/j.biortech.2014.08.046>
- Zhang, Y., Chen, X., Gu, Y., & Zhou, X. (2015). A physicochemical method for increasing methane production from rice straw: Extrusion combined with alkali pretreatment. *Applied Energy*, 160, 39–48. <https://doi.org/10.1016/j.apenergy.2015.09.011>
- Zhao, T., Chen, Y., Yu, Q., Shi, D., Chai, H., Li, L., Ai, H., Gu, L., & He, Q. (2019). Enhancement of performance and stability of anaerobic co-digestion of waste activated sludge and kitchen waste by using bentonite. *Plos One*, 14(7), 1–20. <https://doi.org/10.1371/journal.pone.0218856>
- Zheng, M., Li, L., Li, X., Xiong, J., Mei, T., & Chen, G. (2010). The effects of alkaline pretreatment parameters on anaerobic biogasification of corn stover. *Energy Sources, Part A: Recovery, Utilization and Environmental Effects*, 32(20), 1918–1925. <https://doi.org/10.1080/15567030902937119>
- Zhou, M. M., Yan, B. H., Wong, J. W. C., & Zhang, Y. (2018). Enhanced volatile fatty acids production from anaerobic fermentation of food waste: A mini-review focusing on

acidogenic metabolic pathways. *Bioresource Technology*, 248, 68–78.
<https://doi.org/10.1016/j.biortech.2017.06.121>

RESEARCH OUTPUTS

(i) Publications

Richard, E. N., Hilonga, A., Machunda, R. L., Njau, K. N. (2019). A review on strategies to optimize metabolic stages of anaerobic digestion of municipal solid wastes towards enhanced resources recovery. *Sustainable Environment Research*, 29 1–13. <https://doi.org/10.1186/s42834-019-0037-0>

Richard, E. N., Hilonga, A., Machunda, R. L., Njau, K. N., (2020). Two-stage banana leaves wastes utilization towards mushroom growth and biogas production. *3Biotech*, 10, 542. <https://doi.org/10.1007/s13205-020-02525-6>

Richard, E. N., Hilonga, A., Machunda, R. L., Njau, K. N. (2021). Life cycle analysis of potential municipal solid wastes management scenarios in Tanzani: the case of Arusha City. *Sustainable Environment Research*, 3, 11-13. <https://doi.org/10.1186/s42834-020-00075-3>

(ii) Poster Presentation

