

2020-02

# Innovative secured water quality monitoring system using remote sensors: case of pangani water basin

Mwemezi, Kaizilege Webb

NM-AIST

---

<https://doi.org/10.58694/20.500.12479/908>

*Provided with love from The Nelson Mandela African Institution of Science and Technology*

**INNOVATIVE SECURED WATER QUALITY MONITORING SYSTEM  
USING REMOTE SENSORS: CASE OF PANGANI WATER BASIN**

**Kaizilege Webb Mwemezi**

**A Dissertation Submitted in Partial Fulfillment of the Requirements for the Degree of  
Master's in Information and Communication Science and Engineering of the Nelson  
Mandela African Institution of Science and Technology**

**Arusha, Tanzania**

**February, 2020**

## **ABSTRACT**

The decline of water quality in rivers and water basins caused by toxic chemicals, domestic wastes and farm implements has become an ever-growing problem world wide. Population growth, industrial and agriculture activities are the leading factors in polluting water sources. At present, monitoring of water quality in rivers is so important due increase in waterborne diseases and scarcity of clean water. However, acquiring real-time, accurate, reliable and secured data is still a major challenge during monitoring of water quality in most river basins existing in developing countries like Tanzania.

This study was conducted in upper Pangani river basin located in Arusha and Kilimanjaro regions, Tanzania. Therefore, this study presents an innovative secured water monitoring, control and management system using remote sensors, which has been developed to monitor physiochemical parameters including pH, turbidity, temperature and dissolved oxygen. In undertaking the study, a qualitative approach was used for gathering system requirements through interviews with Pangani water basin information and communications technology staffs ,water quality engineers and document reviews. From obtained qualitative information the system was developed using dynamic system development methodology. As a result, the innovative, low cost, reliable and secure system was successfully developed consisting of four basic operational modules. The proposed system demonstrated the following results: real-time measurements were taken from various water monitoring stations in the river basin at low-cost and accurate, secure data transmission and storage from remote sensors to a central office management system, measurements are visualized in a simple and clear manner by officials of different level of expertise, the system provided decisions support on the quality of water present in the rivers and water basins by evaluating the measurements and also provided short message services alerts once the standards are exceeded.

## DECLARATION

I, **Kaizilege Webb Mwemezi**, do hereby declare to the Senate of Nelson Mandela African Institution of Science and Technology that this dissertation is my own original work and that it has neither been submitted nor being concurrently submitted for degree award in any other institution.



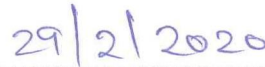

.....  
**Signature**

.....  
**Date**

The above declaration is confirmed by:





.....  
**Dr. Anael Sam**  
**Supervisor**

.....  
**Date**

## **COPYRIGHT**

This dissertation is a copyright material protected under the Berne Convention, the copyright Act of 1999 and other International and National enactments, in that behalf, an intellectual property. It should not be reproduced by any means, in full or in part, except for short extracts in fair dealing, for research or private study, critical scholarly review or discourse with an acknowledgement and without a written permission of the Deputy Vice Chancellor for Academic, Research and Innovation, on behalf of both the author and the Nelson Mandela African Institution of Science and Technology.

## CERTIFICATION

I, the undersigned certify that I have read and hereby recommends for acceptance by The Nelson Mandela African Institution of Science and Technology, a dissertation entitled, “Innovative Secured Water Quality Monitoring Systems using Remote Sensors: A case of Pangani Water Basin”, submitted in partial fulfilment of the requirements for award of the degree of Master’s in Information and Communication Science and Engineering.

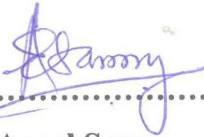

.....  
**Dr. Anael Sam**  
**Supervisor**

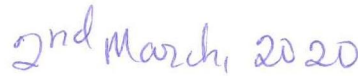

.....  
**Date**

## **ACKNOWLEDGEMENT**

First of all, I would like to thank the Almighty God for his blessings, grace and guidance during my time as a student.

Secondly, I would like to express my sincere gratitude to my supervisor Dr. Anael Sam, who has been with me throughout the process of conducting this research. I would like to thank him for guidance, constructive comments and support throughout the entire process. He was always available for regular meetings and discussions, which helped me to produce this dissertation.

I would like to thank Pangani water basin authority for the permission to conduct my research study. Also, many thanks go to 2017 classmates and lecturers for their immense support during my study.

Finally, I would like to express my sincerely gratitude to my parents Emmanuel Mwemezi, Consolatha Mwemezi and the whole family for their support, prayers and blessings during my graduate studies.

## TABLE OF CONTENTS

ABSTRACT.....	i
DECLARATION .....	ii
COPYRIGHT.....	iii
CERTIFICATION .....	iv
ACKNOWLEDGEMENT .....	v
TABLE OF CONTENTS.....	vi
LIST OF TABLES.....	x
LIST OF FIGURES .....	xi
LIST OF APPENDICES.....	xiii
LIST OF ABBREVIATIONS AND SYMBOLS .....	xiv
CHAPTER ONE .....	1
INTRODUCTION .....	1
1.1 Background of the Problem .....	1
1.2 Statement of the Problem.....	2
1.3 Rationale of the Study.....	3
1.4 Research Objective.....	3
1.4.1 General Objective.....	3
1.4.2 Specific Objectives.....	3
1.5 Research Questions .....	4
1.6 Significance of the Study .....	4
1.7 Delineation of the Study.....	5
CHAPTER TWO .....	6
LITERATURE REVIEW .....	6



2.1 Introduction.....	6
2.2 The History of Water Quality Assessments Studies in Tanzania .....	6
2.3 The Role of ICT in Water Sources Management.....	7
2.3.1 Importance of Water Resource Management.....	7
2.3.2 Water Quality Assessment Parameters.....	8
2.3.3 Application of ICTs in Water Resource Management .....	8
2.4 Scientific Operations of Sensors in Measuring Water Quality .....	10
2.4.1 In-Situ Remote Sensors Used for Measuring Water Quality .....	10
2.4.2 Scientific Operation of pH Sensor.....	10
2.4.3 Scientific Operation of Dissolved Oxygen (DO) Sensor .....	11
2.4.4 Scientific Operation of Turbidity Sensor .....	12
2.4.5 Scientific Operation of Temperature Sensor .....	12
2.5 Overview of Wireless Transmission Technologies in Remote Sensing .....	13
2.5.1 ZigBee .....	14
2.5.2 Wi-Fi .....	14
2.5.3 Global System for Mobile Communication (GSM) .....	14
2.6 Related Water Quality Monitoring Systems .....	15
CHAPTER THREE .....	20
MATERIALS AND METHODS.....	20
3.1 Introduction.....	20
3.2 Research Design Approach.....	20
3.3 Relevance and Rigor Cycle.....	21
3.3.1 Study Area.....	21
3.3.2 Sampling Design .....	23
3.3.3 Data Collection.....	23

3.3.4 Data Analysis .....	24
3.4 Design Cycle.....	25
3.4.1 System Modelling.....	25
3.5 System Implementation .....	26
3.5.1 Sensor Selection Method.....	26
3.5.2 Django Model View Controller.....	27
3.5.3 JetBrains PyCharm Editor .....	28
3.5.4 MySQL Database .....	28
3.5.5 Hypertext Markup Language, Cascading Style Sheet and Java Script .....	28
3.6 System Testing and Validation .....	28
3.6.1 MATLAB Simulink .....	29
3.6.2 White Box and Black Box Testing.....	29
CHAPTER FOUR.....	30
RESULTS AND DISCUSSION .....	30
4.1 Introduction.....	30
4.2 Results and Discussions from Study Area and Related Document Review .....	30
4.2.1 Water Quality Parameters Monitored in Pangani River Basin.....	30
4.2.2 Assessments of Causes of Water Pollution in Pangani River Basin .....	31
4.2.3 Challenges of Existing Water Quality Monitoring System in The Pangani Basin .....	32
4.3 Design of An Innovative Water Quality Data Monitoring System for The River Basin .....	34
4.3.1 Functional and Non-functional Requirements .....	34
4.3.2 System Modelling.....	36
4.3.3 System Design Architecture .....	37
4.4 System Implementation.....	47

4.4.1 Selection of Sensor Components for Development Data Acquisition .....	47
4.4.2 Connections of Sensing Components for Data Acquisition Unit.....	52
4.4.3 Reading and Calibrating Data From Sensors .....	53
4.4.4 Data Transmission and Security Unit.....	54
4.4.5 Database Implementation .....	56
4.4.6 Decision Support Module Implementation .....	56
4.4.7 Web Application Implementation .....	58
4.5 System Testing and Validation .....	64
4.5.1 Simulation of Sensor Circuits.....	64
4.5.2 Web Application System Unit Testing.....	66
4.5.3 System Performance Test.....	68
CHAPTER FIVE .....	73
CONCLUSION AND RECOMMENDATIONS .....	73
5.1 Conclusion.....	73
5.2 Recommendations .....	74
REFERENCES .....	75
RESEARCH OUTPUTS.....	94

## LIST OF TABLES

Table 1: Summary of Reviewed Water Quality Monitoring Systems .....	19
Table 2: Number of Respondents in The Study Conducted in Pangani Water Basin.....	23
Table 3: Functional Requirements .....	35
Table 4: Non-Functional Requirements.....	36
Table 5: Use Case Components .....	40
Table 6: Candidate Sensors' Specifications.....	45
Table 7: List of Identified Single Board Computers.....	46
Table 8: Sensing Condition and Constraints for Identified Sensors .....	47
Table 9: User Authentication Test .....	67
Table 10: Tabular and Graphical Test .....	67
Table 11: SMS, AES Encryption and Report Generation Unit Testing .....	68
Table 12: pH Sensor Performance Test .....	69
Table 13: Turbidity Sensor Performance Test .....	70
Table 14: Dissolved Oxygen Performance Test .....	70
Table 15: Temperature Sensor Performance Test.....	71
Table 16: Single Board Computer Performance Test.....	71

## LIST OF FIGURES

Figure 1: Trend of Subscription on Mobile and Fixed Lines in Millions (TCRA, 2017) .....	5
Figure 2: Global Population of Improved Water Sources .....	9
Figure 3: Relation of Design Science Cycles (Adikari <i>et al.</i> , 2009).....	21
Figure 4: Map Showing Pangani River Basin (Palt, 2002).....	22
Figure 5: Workflow of QDA Lite Miner for Analysing Textual Data .....	25
Figure 6: Flow of Sensor Selection Method (Hirayama, 2016).....	27
Figure 7: Distribution of Water Quality Parameters as Monitored in Pangani Basin .....	31
Figure 8: Causes of Water Pollution in River Basin.....	32
Figure 9: Assessment of Challenges in Monitoring Water Quality in Pangani River Basin.	34
Figure 10: Conceptual Design Framework.....	38
Figure 11: Circuit Diagram for Data Sensing Unit.....	39
Figure 12: Use Case Diagram for ISWQMSRS .....	41
Figure 13: Data Flow Diagram for Innovative Secure Water Quality Monitoring System Using Remote Sensor. ....	42
Figure 14: Block Diagram Architecture for Innovative Secure Water Quality Monitoring Using Remote Sensor. ....	43
Figure 15: pH Sensor Module.....	48
Figure 16: Turbidity Sensor Module .....	49
Figure 17: Dissolved Oxygen Sensor Module .....	49
Figure 18: Temperature Sensor Module .....	50
Figure 19: Raspberry Pi 3 Model B Single Board Computer .....	51
Figure 20: ADS1115 Module .....	52
Figure 21: Connections of Sensing Components for Data Acquisition Unit.....	53
Figure 22: M028AT Wireless Module.....	54
Figure 23: Flowchart Diagram for Sensor Measurements and AES Encryption.....	55
Figure 24: Relation Schema.....	56
Figure 25: Flow Chart Diagram for Decision Support Module.....	58
Figure 26: User Authentication Interface .....	59
Figure 27: System Administration Interface.....	59
Figure 28: Administration Interface.....	60
Figure 29: Encrypted Sensor Measurements Interface .....	61

Figure 30: Sensor Measurements Displayed in Tabular Format .....	61
Figure 31: Real-Time Water Quality Information Displayed in Graphical Format .....	62
Figure 32: Water Quality Report in PDF Format .....	63
Figure 33: SMS Sent to Specific Officials After pH Value Exceed Standard Limit .....	63
Figure 34: pH Simulation Sensor Circuit .....	65
Figure 35: Liner Relationship Between pH as Output Voltage and Input Voltage .....	65
Figure 36: Temperature Sensor Simulation Circuit .....	66
Figure 37: Exponential Relationship Between Thermistor and Temperature .....	66

## LIST OF APPENDICES

Appendix 1 :	Django Python Code Innovative Secure Water Quality Monitoring System	84
	Using Remote Sensor Code .....	84
Appendix 2 :	Interview Guide.....	87
Appendix 3 :	Data Collection Introductory Letter .....	89
Appendix 4 :	The Research Approval Letter .....	90
Appendix 5 :	Java Script, HTML and Python Code For Web Application .....	91

## LIST OF ABBREVIATIONS AND SYMBOLS

ACRONYM	DEFINITION
1G	First Generation
3G	Third Generation
API	Application Programming Interface
BMI	Bright Modern Innovative
BOD	Biochemical Oxidation Demand
BSC	Base Switching Center
BTS	Base Transceiver Station
CCL	Creative Common Licence
CH	Chlorophyll
CMS	Central Management System
COD	Chemical Oxygen Demand
DAU	Data Acquisition Unit
DFD	Data Flow Diagram
DO	Dissolved Oxygen
DOC	Dissolved Organic Carbon
DSDM	Dynamic Science Design Methodology
DSR	Design Science Research
Fe	Iron
GIS	Geographical Information System
GMSC	Gateway Mobile Switching Center
GPRS	General Packet Radio Service
GSM	Global System for Mobile Communication
Hg	Mercury
HLR	Home Location Register
HTML	Hyper Text Markup Language
ICT	Information and Communication Technology
IEEE	Institute of Electrical and Electronics Engineers
ISC	International Switching Center
ISO	International Organization Standard



ISWQMSRS	Innovative Secure Water Quality Monitoring System using Remote Sensor
JS	JavaScript
K	Conductivity
LAN	Local Area Network
LTE	Long Term Evolution
MoWI	Ministry of Water and Irrigation
MSC	Mobile Switching Center
MVC	Model View Controller
Na	Sodium
NH <sub>4</sub> NO <sub>3</sub>	Ammonia Nitrate
NO <sub>3</sub> <sup>-</sup>	Nitrate
NTU	Nephelometric Turbidity Unit
OFDM	Orthogonal Frequency Division Multiplexing
OMC	Operation and Maintenance Centre
P	Phosphorus
Pb	Lead
PBWB	Pangani Basin Water Board
PLC	Programmable Logic Controller
PO <sub>3</sub> <sup>3-</sup>	Phosphate
Py	Python
RF	Radio Frequency
QDA	Qualitative Data Analysis
SCADA	Supervisory Control and Data Acquisition
SDG	Sustainable Development Goal
SMS	Short Message Service
SO <sub>4</sub> <sup>2-</sup>	Sulphate
TA	Total Alkalinity
TC	Total Caliform
TCRA	Tanzania Communications Regulatory Authority
TDS	Total Dissolved Solids
TEMP	Temperature

TMA	Tanzania Meteorological Agency
TOC	Total Organic Carbon
TS	ThingsSpeak
TSS	Total Suspended Solid
TURB	Turbidity
UN	United Nations
UNNWWD	United Nation World Water Development
VLR	Visitor Location Register
WAN	Wide Area Network
WBA	Water Basin Authorities
WCDMA	Wideband Code Division Multiple Access
WI-FI	Wireless Fidelity
WL	Water Level
WQMS	Water Quality Monitoring System
WQP	Water Quality Parameter
WSDP	Water Sector Development Programme
WSN	Wireless Sensor Networ

# CHAPTER ONE

## INTRODUCTION

### 1.1 Background of the Problem

The decline of water quality in rivers caused by toxic chemicals, domestic wastes and unnecessary nutrients subsequent to the combination of human activities has become an ever-growing problem worldwide (Chilundo, Kelderman & Ókeeffe, 2008). As outlined by many researchers, industrial activities, agriculture activities and population growth are the leading drivers in polluting water sources (Kulinkina *et al.*, 2017; Sotomayor, Hampel & Vázquez, 2018). Consequently, the contamination of water sources caused by the mentioned activities has caused a major concern in the health and environment of the involved individuals and the general public. The alarming rates of waterborne disease cases and scarcity of clean and quality water sources have caused many countries around the world to collaborate in programs that will ensure sustainable water management through an integrated approach in order to minimize the problems caused by poor water quality (United Nation Environment Programme, 2017).

In Tanzania, the Ministry of Water and Irrigation (MoWI) through Water Sector Development Programme (WSDP 2006-2025) is responsible to ensure that water sources including rivers, dams, lakes and groundwater are properly managed and monitored by providing the necessary resources. For instance, Water Basin Authorities (WBA) under the MoWI have established the network of monitoring stations mainly in major rivers to monitor meteorological, quality and quantity aspects of water in the respective river basins. As a result, the measurements obtained from stations have become a crucial part in assessing and protecting water sources in the basins (MoWI, 2016).

However, the main challenge faced by WBA is lack of modern and sophisticated equipment to measure physical, chemical and biological water parameters in a timely, accurate and reliable manner (Chapman *et al.*, 2016). The present water monitoring systems in the basins are divided into two categories, which are manual systems and data loggers. The process of monitoring water quality parameters through manual systems involves collection of water samples from various stations in the river basins and sending them to a laboratory where each sample is measured and results are obtained and recorded. Furthermore, data loggers installed in various stations record two type of measurements, which are water level and meteorological data,

whereby the experts from the WBA collect them through universal serial bus flash drive for assessment and analysis. Both systems are less efficient because they takes long time to obtain sample results and they are expensive in terms of manpower and finances required to facilitate the monitoring process. In addition, the storage and security of data collected from the stations are insecure because data are stored in manual books and paper files (Gholamzadeh & Nabovati, 2008; Ministry of Water, 2015).

## **1.2 Statement of the Problem**

Despite the efforts made by different stakeholders MoWI, WBA and Tanzania Meteorological Agency (TMA) in developing Information and Communication Technology (ICT) based water infrastructure, absence of a platform specifically for monitoring water quality parameters has remained a problem (United Nation Development Programme, 2013). Taking the Pangani river basin as a case study, the existing electronic monitoring systems can only provide meteorological and water quantity parameters while the water quality parameters are captured manually (Ministry of Water, 2015). According to MoWI, absence of real time water quality data collection causes the following challenges to basin authorities:

- (i) Lack of enough water quality data to guide the decision-making process since, data are collected only four times in a year.
- (ii) The existing manual procedures of collecting water quality data samples from various water stations and bringing them to laboratories for measurement and analysis is costly and time consuming.
- (iii) The collected water quality information in the basin is subjected to loss and untrustworthy since they are stored in paper files.
- (iv) Inaccurate data emanating from insufficient expertise for conducting measurements, experiments and analysis of water quality.

Therefore, this study aimed at developing water quality monitoring and management system for capturing Dissolved Oxygen (DO), Temperature (TEMP), Turbidity (TURB) and pH so as to overcome the mentioned challenges.

### **1.3 Rationale of the Study**

Management of water quality in rivers has become a major concern in many countries due to increase of waterborne diseases and scarcity of clean water. Both domestic and industrial activities are the major contributors in contaminating water bodies. The urgent need of safeguarding water quality in water bodies has propelled policy makers, researchers, scientists and governments to establish programmes that will ensure proper preservation of water sources. This study provide a secure method of monitoring and managing water quality parameters through :

- (i) Collecting real-time sensor measurements including DO, TEMP, TURB and pH from remote water stations to central office using sensitive, small size and low power sensor nodes.
- (ii) Secure transmission and storage of sensor measurements using Advance Encryption Standards (AES) from sensing unit to a remote database.
- (iii) Visulization of sensor measurements through tabular and graphical formats.
- (iv) Provision of alerts messages to basin officials once sensor measurements exceeds standard values.
- (v) Generation of report to basin officials for assessments and other official uses.

### **1.4 Research Objective**

#### **1.4.1 General Objective**

To develop an innovative secure remote sensing water quality monitoring system that would capture the pH, TURB, TEMP and DO to aid proper interventions and preservation of water sources in the basins.

#### **1.4.2 Specific Objectives**

The specific objectives of this research were:

- (i) To study and analyze existing water quality monitoring systems and identify the essential components for proper interventions and preservation of water sources.

- (ii) To design and implement a secured water quality information system that will be able to capture pH, TURB, DO and TEMP.
- (iii) To validate the water quality monitoring system for intervention and preservation of water sources.

### **1.5 Research Questions**

The research questions of this research were:

- (i) What attributes and components in the existing water quality monitoring and management systems are essential for decision making on water sources preservation and management?
- (ii) How could the secure water quality monitoring and management system be developed to capture the water quality data in the river basin and enhance real time monitoring and decision making?
- (iii) How could the functions, effectiveness and efficiency of the developed water quality monitoring system be determined when subjected to the study environment?

### **1.6 Significance of the Study**

This research provided a secure method of monitoring and managing physical water quality parameters. For instance, the WSDP and MoWI have initiated different ICT projects on water infrastructure, so as to increase performances of services offered by the water sector. These programmes encourage the use of ICT in water sector as a tool for making key decisions (MoWI, 2016). In addition, the report of United Nations Development Programme (2013) shows that there exists a large gap between monitoring and sharing of information among water and climate information users in Tanzania, the factor that has led to high cost of running infrastructure and duplication of data. This has consequently led to lack of credible sources in providing accurate data. Hence, this study ensured sharing of information among water sector and climate information users in order to have reliable data sources.

Furthermore, monitoring and management of water quality parameters is very important, as studies have shown that climate changes have effect on freshwater resources, such as changes in hydrological cycle, impact on run off, flood intensity and period of low flow in the water sources (Wu, Xiao, Lu & Chen, 2015). These changes apart from affecting water quality, they also have effects on water resources management and social economical activities.

According to the Bright Modern Innovative (BMI) (2016) report, the coverage of mobile communication services in Tanzania had reached 71% and the Tanzania Communications Regulatory Authority (TCRA) (2017) report estimates the number of mobile communication subscribers to be more than 40 million people as shown in Fig. 1. The penetration of telecommunication network in both rural and urban areas could be a useful tool of monitoring and managing water resources quality and for improvement of the systems performance.

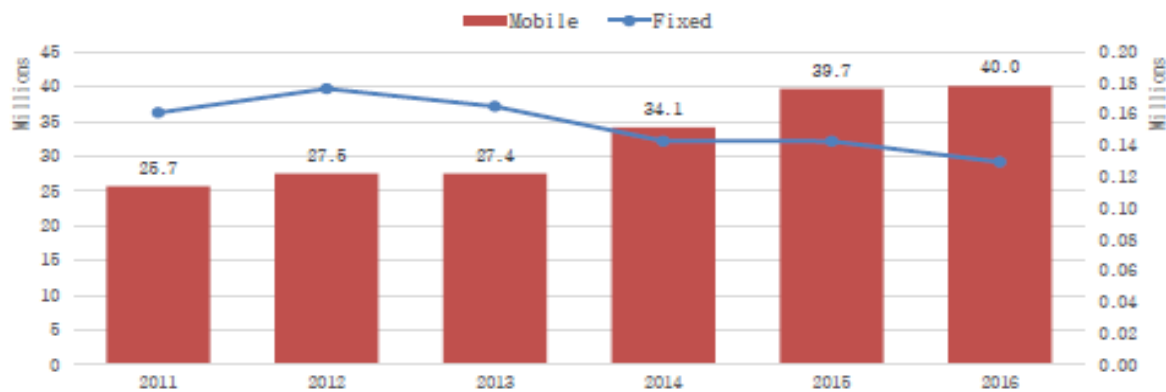

**Figure 1:** Trend of Subscription on Mobile and Fixed Lines in Millions (TCRA, 2017)

### 1.7 Delineation of the Study

Monitoring of water quality in river basin is a broad field. This research is not intended to cover the entire domain of water quality monitoring. Rather, it focuses on monitoring of four physical water quality parameters which are pH, DO, TEMP and TURB. In the part of monitoring these four water quality parameters, the focus is on the use of low cost, low power and high sensitive sensor modules whereas in transmission the focus is on the use of AES and cellular mobile networks to secure and transmit data to a central database. Presentational layer, focus is on the use of Hyper Text Markup Language (HTML), Javascript (JS) and Python (Py) to make graphs, tables and document reports files.

## **CHAPTER TWO**

### **LITERATURE REVIEW**

#### **2.1 Introduction**

This chapter provides the review of the main concepts that were used in developing the innovative secure water quality monitoring and management system in the river basin in Tanzania. It also describes how the study relates with prior researches, its originality and relevance to the research problem.

Specifically, the chapter focuses on the history of water quality of rivers in Tanzania by assessing: role of ICT in water sources management, scientific operations of sensors in measuring water quality parameters, overview of wireless transmission technologies in remote sensing and related water quality monitoring systems.

#### **2.2 The History of Water Quality Assessments Studies in Tanzania**

Historically, the studies on the status of water quality in Tanzania started in 1971, whereby several researches were conducted to determine main causes of water pollution in rivers found mostly in cities and town areas (Mohammed, 2014). However, recent studies conducted in Dar es salaam city on the effect of waste water discharge have revealed that, there is presence of large quantities of organic and non-organic materials covering the large part of Msasani River, which is caused by industrial, agriculture and environmental activities (Ahmad, 2015). Related studies on the concentration of heavy metals, organic and non-organic metals found that, there is a significant effect on the quality of water in Msasani river caused by metals such as lead, iron, manganese and cadmium (Chanzi, 2017; Mohammed, 2014). From these studies, researchers proposed construction of separate sewage systems around the city to reduce the disposal of unwanted materials in the Msasani river.

Another research study conducted in Zanzibar by Mato (2015) on the status of water quality parameters through analysis of pH, TEMP, Biological Oxidation Demand (BOD), Chemical Oxidation Demand (COD), DO, Conductivity (K) and Total coliforms (TC) recommended that, proper environmental policy should be formulated in order to prevent activities which cause continuous decline of water quality in water sources .



Furthermore, in the year 2014, Integrated Water Sanitation and Hygiene (IWASH) program under United State Agency for International Development (USAID) conducted a survey to assess the water quality of different sites along the Ruvu river basin in Tanzania. The survey used in-situ measurement techniques to measure DO, TEMP, K, sulphates ( $\text{SO}_4^{2-}$ ), ammonia nitrates ( $\text{NH}_4\text{NO}_3$ ), COD and TC. The survey revealed that, there were large variations of measurements recorded from site to site caused by different factors such as geographical area, human activities and industrial activities. Likewise, the study showed that human activities such as agriculture, domestic uses and livestock keeping are the major factors that contributed to the decline of water quality mostly in rivers situated in the rural areas. Moreover, economic activities such as industrial, construction, poor sewage systems and waste disposal were noted as the leading factors in polluting rivers existing in urban areas (GLOWS-FIU, 2014).

## **2.3 The Role of ICT in Water Sources Management**

### **2.3.1 Importance of Water Resource Management**

The importance of water resources management worldwide cannot be overemphasized. According to the United Nation World Water Development (UNWWD) Report, by 2050, at least one in four people is likely to live in a country affected by chronic or recurring shortages of freshwater (United Nations, 2015). The demand for water at personal, household and enterprise needs has increased the competition for water use and the world water resources are under increasing stress due poor management, climate change and pollution.

In addition, development activities such as hydropower constructions, industrial activities and infrastructure development contribute to decline of water quality through disposal of wastes in water sources. These wastes usually carry toxic chemicals such as lead (Pb), mercury (Hg), iron (Fe),  $\text{SO}_4^{2-}$ , nitrates ( $\text{NO}_3^-$ ) and other harmful chemicals, which are the main causes of deaths and diseases for the living organisms dependent on these water sources. Moreover, study shows that, freshwater is under serious threat caused by multiple stressors such as organic and inorganic pollutants, land degradation, pathogens and change of land uses (Navarro-Ortega *et al.*, 2015). Generally, the combination of multiple stressors results to formation of complex chemical compounds, which have impacts in quality of water bodies and other ecosystems in water.

The statement from the Sustainable Development Goal (SDG) No.6 notes that “Too many people still lack access to safely managed water supplies and sanitation facilities. Water

scarcity, flooding and lack of proper wastewater management hinder social and economic development” (World Bank, 2018, p. 7). Hence, United Nations (UN) calls for increasing water efficiency and improving water management in order to balance the competing and growing water demands from various sectors and users.

### **2.3.2 Water Quality Assessment Parameters**

In the field of water quality monitoring, remote sensors are used to estimate physical properties, organic properties and microbiological properties of water. The physical properties of water include parameters such as TEMP, pH, K, Total Dissolved Solids (TDS), Total Suspended Solids (TSS), TURB and Total alkalinity (TA). The organic properties includes parameters such as BOD, Total Organic Carbon (TOC), Dissolved Organic Carbon (DOC) and microbiological parameters which includes TC and chlorophyll (CH) (Abdelmalik, 2016; Gholamzadeh & Nabovati, 2008).

### **2.3.3 Application of ICTs in Water Resource Management**

The application of ICT is very important in ensuring proper management of water sources (Soto-Garcia, Del-Amor-Saavedra, Martin-Gorriiz & Martínez-Alvarez, 2013). Information and Communications Technologies have been used as enablers in the management of water as a natural resource. Information and Communications Technologies can facilitate the collection and analysis of data and information on water sources and potentially improve their management and enumeration (Leshan, 2017). In other countries, technologies such as remote sensing and geographical information systems have been used by water authorities to track water usage and forecast river levels. These technologies have also been applied in irrigation and water based early warning systems.

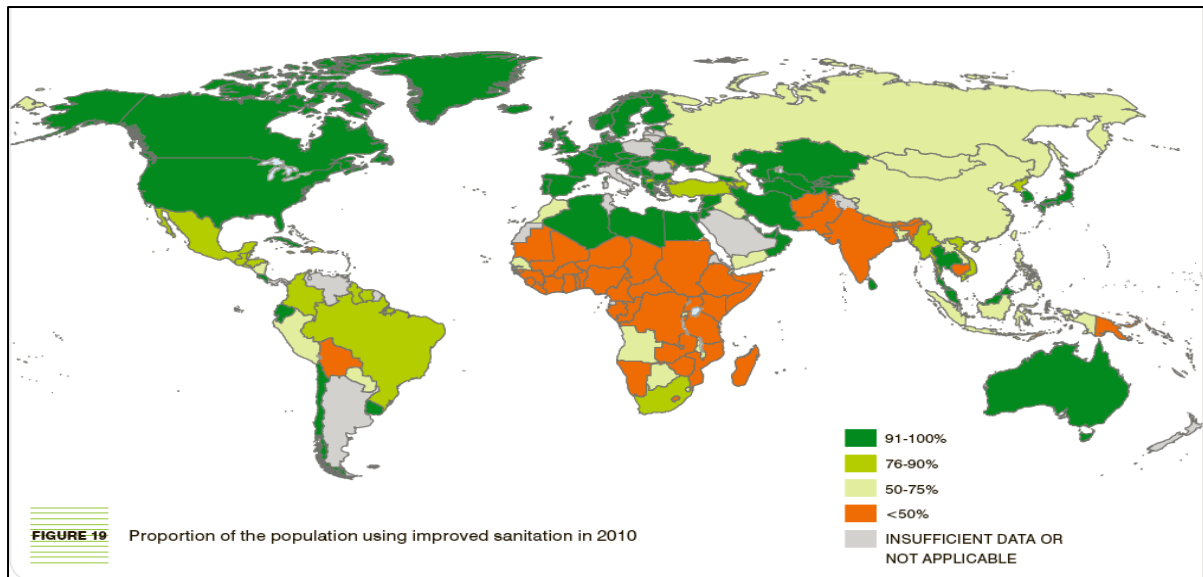

**Figure 2:** Global Population of Improved Water Sources (World Health Organization & United Nation International Children’s Emergency Fund, 2012).

Currently, in developing countries like Tanzania, the process of monitoring and analyzing water quality in water sources such as rivers, lakes and ground water is facing many challenges: lack of modern equipment that can be used to monitor water quality parameters accurately and reliably, relative high cost of conducting in-situ measurements in many sites located in distant and remote places, lack of expertise for conducting measurements, experiments and analysis of water quality since these activities need training as well as experience on achieving accurate results and existing manual processes of monitoring water quality parameters are not only time consuming but also cause loss of data because the information is kept in manual books and files (Ministry of Water and Irrigation, 2016; United Nation Development Programme, 2013).

However, in order to attain proper management of water and water quantity in river basins some key elements need to be considered including, identification of information needed, formulation of strategies that will be used to assess the information, developing programs that will be used to monitor the required information, data collection, data handling, data analysis and report generation (Oosthuizen, Hughes, Kapangaziwiri, Mwenge Kahinda & Mvandaba, 2018). These elements can be easily achieved through using ICT related tools such as Wireless Sensor Networks (WSN), Geographical Information System (GIS) and Supervisory Control and Data Acquisition (SCADA) (Soto-Garcia *et al.*, 2013). Generally, applying ICT tools in the field of water quality monitoring and management have proven beneficial compared to

traditional methods since, large amount of real-time information can be collected in many forms including text, video and images and protected with low cost (Cavazza, 2018). Hence, ICT could be reliable in remote areas and in tough conditions such as during rainy seasons. Also, the large amount of information collected from water sources can be easily analysed and manipulated to provide insight and performance of various water parameters using intelligent software tools (GoldSim, 2017). Moreover, ICT can provide security and storage of information so as to prevent them from loss and denial of service (Byeon, Choi, Maeng & Gourbesville, 2015).

## **2.4 Scientific Operations of Sensors in Measuring Water Quality**

### **2.4.1 In-Situ Remote Sensors Used for Measuring Water Quality**

Over the past few decades, application of remote sensing technologies have become a fundamental driver in providing information for environmental monitoring by improving the availability of measurements and systems observations (Zafar, Islam & Ahmed, 2014). Generally, the existence of large amount of earth observation-based information has become essential for making cost-effective, predictive and forward-looking decisions, which are applied basically in the environmental planning and risk mitigation.

The principal operation of sensors is to use the most commonly detectable phenomena such as chemical, biological, mechanical, optical, magnetic, electric, heat and radioactivity convert them to electrical signals (Prasad, Mamun, Islam & Haqva, 2015). These electrical signals are calibrated to provide measurements that are understandable by humans. In that perspective, Gordon, Callan & Vickers (2008) outlined several factors for choosing the water quality parameters to be used for remote sensing including effectiveness and easy control, capability to indicate performance when needed, easy measurement and provision of needed response. Therefore, based on the mentioned factors, five water quality parameters (pH, K, DO, TURB and TEMP) have been identified by water scientists as the most important parameters when analysing the status of quality in water sources (Gordon, Callan & Vickers, 2008).

### **2.4.2 Scientific Operation of pH Sensor**

pH is the measurement of alkalinity and acidity of sample solutions. It is used to provide information about test of water. The measurements of pH scale run from 0 to 14 is divided into

three categories: pH value less than 7 indicates acidic solutions, pH value greater than 7 indicates the alkaline solution and pH value equal to 7 indicates neutral solution.

pH is an important parameter that is measured in nearly every water quality application. In waste water treatment, pH is regulated as part of discharge permitting and many treatment processes are pH dependent. In environmental sampling and monitoring, high or low pH values can be indicative of pollution (Karastogianni, Girousi & Sotiropoulos, 2017).

A typical pH sensor consists of a complete electrical circuit, electrodes and chemical solutions. In its operation one of the electrodes is dipped into a solution of a known pH value usually potassium chloride, while the other electrode is dipped into another solution of unknown pH value. The different chemical properties of solutions create a potential difference, which allow the flow of charge in the circuit. By measuring potential difference between solutions, the hydrogen concentration ( $H^+$ ) can be calculated using the Nernst equation (Ammam, 2018).

$$E_{cell} = E_o - RT \ln (Q)$$

*E cell = potential difference at given Temperature, Eo = potential difference at standard Temperature and pressure (STP)*

*R=Universal gas constant, T = Temperature, Q = reaction quotient of cell reaction*

### **2.4.3 Scientific Operation of Dissolved Oxygen (DO) Sensor**

Dissolved Oxygen is the amount of oxygen which is freely available in water. Dissolved Oxygen is one of the most important indicators of water quality. It is essential for the survival of fish and other aquatic organisms. Oxygen dissolves in surface water due to the aerating action of winds. Oxygen is also introduced into the water as a by-product of aquatic plant photosynthesis (Beynon, Rasmequan & Russ, 2002). Hence, large amounts of DO is present in ground water sources, rivers, streams and water falls, which generally are referred to as moving water.

Electrochemical DO sensor is made up of anode, cathode, electrolyte solution and electric circuit. Electrodes and electrolyte solution are separated by semi-permeable membrane. When dissolved oxygen sensor probe is dipped into water the DO is diffused at a rate that is directly proportional to pressure of oxygen in water. The diffused oxygen is reduced and used by cathode electrode to form an electric current which is directly proportional to oxygen

concentration. The relation between current and pressure can be calculated by using the following equation (Fondriest, 2016).

$$I_d = (4 * F * P_m(t) * A * P_{O_2}) / D$$

*I<sub>d</sub>*= current produced, *F*= Faraday constant(*t*) *P<sub>m</sub>(t)*=Permeability of membrane, *A*= Area of cathode

*P<sub>o2</sub>*=Partial Pressure, *D*= Membrane thickness.

#### **2.4.4 Scientific Operation of Turbidity Sensor**

Turbidity is the measure of opacity present in water caused by small particles which can't be seen by naked eyes. It is among the important physical water parameters that is easy to measure through both in-situ measurement and through remote sensing devices (Pule, Yahya & Chuma, 2017). Turbidity can vary from a river full of mud and silt where it would be impossible to see through the water (high TURB), to a spring water which appears to be completely clear (low TURB). Turbidity can be caused by many factors including, silt, sand, mud, bacteria and chemical precipitates (Myre & Shaw, 2006). Human and weather activities such as mining, agriculture, soil erosion, construction and rain sediments can predispose Turb in water.

According to International Organization for Standardization (ISO) 7027, TURB is measured through the use of optic light whereby incident light that is scattered perpendicular is taken by a photodiode. The photodiode converts the light into electronic signals, which is decoded as Nephelometric Turbidity Unit (NTU). Basically, there are two approaches in measuring turbidity which are nephelometric principles and transmittance principles. Nephelometric principals is preferred to transmittance because it has greater accuracy since it uses forward scattering principles (ISO, 1999).

#### **2.4.5 Scientific Operation of Temperature Sensor**

Temperature is very critical measured quantity in the environment due to its property of causing effects to operations of electronic and non-electronic systems (Prithwiraj Purkait, Budhaditya & Biswas, 2013). There are different types of temperature sensors; however, the thermistor temperature sensor is reported as the most accurate sensor when compared to others (Aleksić & Nikolić, 2017). The Thermistor sensor changes resistance when changes and as opposed to other temperature sensors, thermistors produce a non-linearity property in which a large

resistance range can be produced by a small change in temperature (Paseltiner, Payagala & Jarrett, 2017). The relation between temperature and resistance is calculated by Steinhart-Hart equation.

$$\frac{1}{TEMP} = a + b \ln(R) + c (\ln R)^3$$

Where  $a$ ,  $b$ , and  $c$  = Steinhart-Hart parameters,  $TEMP$  = Temperature and  $R$  = Resistance

## **2.5 Overview of Wireless Transmission Technologies in Remote Sensing**

Wireless Sensor Networks comprises of radio frequency (RF) transceivers, microcontrollers, sensors and power sources (Islam, 2012). Currently advances in wireless sensor networking technology have enabled development of low cost, low power, multifunctional sensor nodes. Sensor nodes allow environment sensing together with data processing (Ruiz-garcia, Lunadei, Barreiro & Robla, 2009). Sensor networks are used for a variety of applications, including machine monitoring and maintenance, wireless data acquisition, smart buildings, highways, environmental monitoring, site security, automated on-site tracking of expensive materials, safety management and in many other areas (Loganathan, 2018).

A general WSN protocol comprises of Transmission Control Protocol/Internet Protocol (TCP/IP) layers and management planes for power, task and mobility. Currently two standard technologies are available for WSN which are ZigBee and Bluetooth. Both work inside the Industrial Scientific and Medical (ISM) band of 2.4 GHz, which permit licence free activities, immense spectrum and compatibility. However, it is additionally conceivable to make a WSN utilizing Wireless Fidelity (Wi-Fi) using the Personal Computer (PC)-based systems (Wang, Zhang & Wang, 2006).

In WSN operation, information obtained from remote sensors is transmitted to a Central Management Systems (CMS) for processing, analysis and decision making. However, in order to achieve that, remote sensing systems should be able to utilize existing wireless communication infrastructures because of its large-scale deployment in many places (Sohraby, Minoli & Znati, 2007). For that reason, most of the remote sensing systems developed in recent years have a capacity to use wireless communication technologies such as ZigBee, Bluetooth, Local Area Network (LAN), Wide Area Network (WAN), Global System for Mobile Communication (GSM), Third Generation (3G) and Long Term Evolution (LTE) (Jimenez &

Taha, 2018). There are different types of wireless communication technologies used in the field of remote sensing such as ZigBee, Wi-Fi and GSM (Barcelo-Ordinas, Chanet, Hou & Garcia-Vidal, 2016). However, the choice of wireless communication technologies to use depends on power consumption, range, security and performance (Sohraby *et al.*, 2007).

### **2.5.1 ZigBee**

ZigBee is an Institute of Electrical and Electronics Engineers (IEEE) 811.15.4 standard of wireless communication protocol, which has the capacity to transmit data at a maximum rate of 250 Kbps. Its operating frequency is 2.4 GHz ISM-Band with a bandwidth of 1.3 Mbps (Wang *et al.*, 2006). Zigbee devices is designed to use low power and short-range distance, the factors that make it suitable in the areas where there is a limited power resource and low bandwidth applications such as medical equipment, home automation and small-scale projects (Ramya *et al.*, 2011).

### **2.5.2 Wi-Fi**

Wireless Fidelity is an IEEE 802.11g standard of wireless communication protocol which has a capacity to transmit data up to 1 Gbps (Mendez *et al.*, 2011). It can operate both in 2.4 GHz ISM-Band and 5.8 GHz ISM-Band with a bandwidth of 83.5 MHz and 300 MHz respectively. Wireless Fidelity devices can connect to internet through Wireless Local Area Network (WLAN) and Wireless Access Points (WAP) which make it suitable for deployment in high densely areas (Yinbiao, Shu, Lanctot, Hao & Desbenoi, 2014). Furthermore, Wi-Fi supports roaming between different Wi-Fi networks and handoff with cellular network. It uses Orthogonal Frequency Fivision Multiplexing (OFDM) which make it able to withstand channel interference. However, Wi-Fi devices often are restricted its operating range (coverage) by obstacles, reflection and absorption since, it needs a line of sight to an access point. In addition to that, Wi-Fi devices are vulnerable to security attacks since, anyone with a Wi-Fi device has a capacity to access the network services (Mendez *et al.*, 2011). Wireless Fideleity supports numerous applications ranging from small projects to large ones including home automation, building and industrial applications (Sohraby *et al.*, 2007).

### **2.5.3 Global System for Mobile Communication (GSM)**

Measurement of water quality using GSM technology has been reported elsewhere (Patil, Patil, Patil & Patil, 2015). Global System for Mobile ccommunication is a second generation of



cellular communication developed by European Telecommunication Standards Institute (ETSI) to replace first generation (1G) of analog cellular communication systems (Sohraby *et al.*, 2007). Global System for Mobile communication uses digital communication system to support its services. In addition, it uses both Frequency Division Multiple Access (FDMA) and Time Division Multiple Access (TDMA) for transferring information from a transmitter to a receiver. Global System for Mobile communication offers numerous services such as voice, data, location-based services, Short Message Services (SMS) and call control services. Depending on the availability of bands of a certain country, GSM can operate in 900 MHz, 1800 MHz and 1900 MHz (Azeez, 2017). Since the architecture, protocol, mobility management and roaming are the same in all countries, GSM allows manufacturing and integration of different network devices of different companies worldwide (Eberspacher, Jorg & Hans, 2001). The GSM architecture is made up of the following components: User Equipment (UE), Base Transceiver Station (BTS), Base Switching Center (BSC), Mobile Switching Center (MSC), Gateway Mobile Switching Center (GMSC), International Switching Center (ISC) and Operation Maintenance Center (OMC) (Rahnema, 2009; Rigelsford, 2003).

In the field of WSN, GSM has largely improved the transfer of information from remote places through the use of data services, SMS and calls (Azeez, 2017). With its capacity to transfer data at rate of up to 472 Kbps, fast establishment of network and large coverage deployment, it ensures both reliability and availability of its network services (Eberspacher *et al.*, 2001).

## **2.6 Related Water Quality Monitoring Systems**

Hu, Wang, Yu, Liu and Qin (2008) developed a water quality monitoring system based Zigbee Based wireless sensor. The system was designed to measure pH level, TURB and TEMP using sensors which were integrated with 8051 microcontrollers. The sensor nodes were connected by high transmission ZMN240 5HP Zigbee module, which use CC2430 transceiver and IEEE 802.15.4 standard. According to the design the system was able to operate with power consumption of 0.00099 mAH and 14.4 mAH for active and sleep mode, respectively. From the measurement the system operated for 12 hours in active mode status. Also the system was able to cover a distance of 210 meter when collecting field data from sensor nodes to base station without obstacles in between. According to Hu *et al.* (2008), the system used 8051 microcontroller that had low processing speed and memory, which could lead to system failure.

In addition, the system had high power consumption rate; hence it lasted only for 12 hours using a battery with capacity of 170 mAH.

In another experiment Vijayakumar and Ramya (2015) developed a real time of monitoring system for water quality in Internet of Things (IoT) environment. The system used raspberry Pi B<sup>+</sup> as power controller integrated with pH sensor, TURB sensor, K sensor, TEMP sensor and DO sensor for the purpose of measuring quality of drinking water. The data collected from sensors was transmitted through USR-WIFI232-X-V4 IoT module. The IoT module sent data to cloud using Wi-Fi. In the experiment, the system was able to send data in the internet. However, the system focused only in collecting sensor data, with no further uses for decision making on water quality. For instance, the system could not generate useful data for pH, TURB, TEMP and DO which could be used to ensure water quality.

With the case of Tanzania, Faustine *et al.* (2014) designed a wireless sensor network prototype for monitoring water quality in Lake Victoria Basin (LVB). The system was designed to measure pH level (Env-40-pH), TEMP (DT18B20), K (Env-40-EC-K0.1) and DO (Env-40-DO) using sensors manufactured by Atlas scientific. ATmega 2560 microcontroller was integrated with all four sensors to form a data acquisition point. General Packet Radio Service (GPRS)/GSM - SIM900 gateway node was used to transmit data from the field to server in the office using the Zigbee module IEEE 802.15.4. The standard used a communication link between sensors modules and GSM/GPRS-SIM900 module. Data acquired from the field was displayed both in tabular and graphical forms using a web application. From the experimental results, the system was able to function well and provide the results as it was expected. However, researchers recommended further study to detect the areas that require fixing. For instance, the Zigbee modules, which were used in the experiment, are designed to use low power and short-range distance of 10 meter (Vijayakumar & Ramya, 2015). Hence, at the expense of low speed data rate and low transmitting and receiving range (< 30 meter) the Zigbee modules are not suitable in areas that have obstacles and distant from sensor nodes. Furthermore, the system usage of sleep mode to minimize the use of battery power consumption is a tricky method because estimating data sampling and data reporting is a complex operation especially for the system that has low data rate. Likewise, the use of clock in estimating waiting time (sleep) is still consuming battery power (Gholamzadeh & Nabovati, 2008).

An improved study was conducted by Max, Weiss and Hierz (2007) using a Smart Coast Multi Sensor System for Monitoring Quality of Water. The system measured pH, Water Level (WL), K, TURB, Phosphate ( $\text{PO}_4^{3-}$ ) and DO. As opposed to other studies, Max *et al.* (2007) used a wireless sensor platform developed by Tyndall that had plug-and-play capabilities to facilitate easy integration of sensor nodes. In addition, Zigbee/IEEE 802.15.4 wireless standard was used to facilitate communication between multi sensor devices using low power consumption. Basically, the system used the intelligent sensor devices, which incorporate transducer electronic datasheet techniques based on IEEE 1451 standard in order to help multi sensors devices to differentiate them from one another in the control and transceiver unit. Also the use of IEEE 1451 standard ensured fault tolerance, modularity and interoperability between sensor nodes. The data collected from the sensing point was transmitted to the central office using GPRS communication protocol whereby computer was utilised for data visualization and storage. Results from the experiment shown that the system was able to perform well (Max *et al.*, 2007).

A related study was conducted by Wang, Ma and Yang (2011) using an online water monitoring system to measure concentration of  $\text{NO}_3^-$ ,  $\text{PO}_3^{3-}$  and pH value in the water. As reported by Wang *et al.* (2011), most of studies in wireless sensor networks concentrate in theoretical approaches such as network life time, routing algorithms and energy resources. Hence, the system they developed paid much attention on the practical approach that used hierarchical organization of sensor nodes to achieve low cost, easy construction and maintenance. The system composed of data acquisition network, which was made up of monitoring sensor devices and sink nodes. Monitoring sensor devices sent data using Zigbee/IEEE 802.15.4 wireless standard to sink nodes, which in turn used GPRS network to send data to remote management system. Zigbee module was composed of MSP430 controller and CC2420RF chip, whereby sink node was made up of GPRS-DTU, Zigbee-module and Programmable Logical Controller (PLC) device. In this system, the PLC device was responsible for measuring concentration of  $\text{NO}_3^-$ ,  $\text{PO}_3^{3-}$  and pH value in the water. The data collected from sensor nodes was sent to remote management system through IP packet whereby it was passed through virtual port service and converted into serial data format. The remote management system consisted of LabVIEW software which was responsible for collecting serial data and converted it into readable form (float). Through Open Database Connectivity (ODBC) interface, all data in the LabVIEW software was stored into MySQL database. Results

from the experiment indicated that the system performed well (Wang *et al.*, 2011). However, the researchers suggested more studies on hidden terminal and packet sequencing to increase performance of the system.

Another study was conducted by Zakaria and Michael (2017) using an integrated cloud based water wireless sensor network for monitoring industrial waste water discharge into water sources. The system monitor pH, DO and K of waste water discharged into water sources. It uses ThingSpeak (TS) cloud to receive sensor data obtained from sensor device installed from water sources. In addition, TS cloud contains special application program for visualizing collected data from sensors in tabular and graphical views. Furthermore, the system uses Arduino uno controller to process signals obtained from sensor nodes and transmit them through GPRS module to the cloud. Moreover, the system send notification messages to community once measured water quality parameters is not up to standard values. However, researcher have not provide security mechanism that will be used to secure confidentiality of sensor measurements with accordance to law governing dissemination of government information since the use of TS cloud is under Creative Common Licence (CCL) hence it can subjected to changes without developer consent. Apart from that, TS cloud allows maximum of 8 data fields hence it limits the amount of other important information that can be collected from sensor nodes including device level information like signal level, signal quality and others which important in determining status of sensor nodes. High consumption of power by sensor nodes and gateway nodes can result to failure of the system since battery is used as the only source of power. The system architecture suggests that, the developed system fit communal use and not official use because it doesn't show the relationship between water quality data and information from water quality control authorities such as WBA and MoWI which are responsible in the management of water sources.

**Table 1:** Summary of Reviewed Water Quality Monitoring Systems

Title	Authors	Parameters	System Architecture	Power	Future work
Water quality monitoring system using Zigbee Based wireless sensor	Hu <i>et al.</i> (2008)	pH, TURB and TEMP	8051 Microcontroller, Zigbee (ZMN2405HP), IEEE802.15.4 wireless standard	5V, Battery Sleep mode,	Increase in processing speed and Power optimization
A real time of monitoring system for water quality in IoT environment	Vijayakumar and Ramya, (2015)	pH, TURB, K, TEMP and DO	Raspberry Pi B+ board, ARM microcontroller, IEEE 802.11. WIFI, USRWIFI232-X-V4 IoT module.	3V, Battery and Electricity	Security concern and Uses cases for decision making
A wireless sensor network prototype for monitoring water quality Lake Victoria Basin	Faustine <i>et al.</i> (2014)	pH, TEMP, K and DO	Env-40-pH, DT18B20, Env-40-EC-K0.1, Env-40-DO, ATmega 2560 microcontroller, GPRS/GSM - SIM900 gateway, Zigbee IEEE 802.15.4, Arduino board	5V, Battery Sleep mode	Low power consumption
Smart Coast Multi Sensor System for Monitoring Quality of Water	Max <i>et al.</i> (2007)	WL, K, TURB, PO <sub>3</sub> <sup>3</sup>	ARM controller, Zigbee/IEEE 802.15.4, IEEE 1451 standard, GPRS	5V Battery,	Increase in processing speed and Power optimization
An integrated cloud based water wireless sensor network for monitoring industrial waste	Zakaria and Michael (2017)	pH, K and DO	Arduino uno, GSM/GPRS module,	5V, Battery	Power optimization, Security enhancement

## CHAPTER THREE

### MATERIALS AND METHODS

#### 3.1 Introduction

This chapter explains materials and methods used in undertaking the study on development of an innovative secure water quality monitoring systems using remote sensors for Pangani river water basin. The study was conducted in bid to exploring simpler and effective solution for monitoring and managing river water quality. The chapter is arranged in such a way that it answers the research questions raised in chapter one by exploring the existing situation of monitoring water quality in the research study area, data collection methods, system requirements, architecture design, simulation methods and prototype requirements used in developments of sensing units. In addition, it comprises of the design of a web application system for monitoring and management of water quality.

#### 3.2 Research Design Approach

In achieving the general objective of the study on Innovative Secure Water Quality Monitoring System using Remote Sensors (ISWQMSRS), the Design Science Research (DSR) approach was selected. The approach was selected because of the following factors: DSR has root to engineering discipline and aims at defining real problem, it stress on delivering new products such as systems, concepts and models based on the real world problem from environment, collection of requirements for development of information system artefacts is based on existing systems and problem solution and it reflect on information system design theory thereby create a conceptual framework for the study of a given problem (Weber, 2012). In its architecture, the DSR is made up of three cycles which are relevance cycle, design cycle and rigor cycle as shown in Fig. 3. The relevance cycle has a character of capturing an innovative idea or a solution by identifying and representing a problem or opportunity presented in actual environmental. The design cycle is where the process of developing a solution or a product take place. It includes constructing, evaluating and using the feedback to provide an intended solution to the problem identified in relevance cycle. The rigor cycle is used to provide knowledge base to a researcher regarding an innovation or idea. This is achieved by referencing on the related works and scientific method in order to come up with a new solution which is different from existing designs. Figure 3 present, a relation of design science cycles (Adikari, Mcdonald & Campbell, 2009; Geerts, 2011).

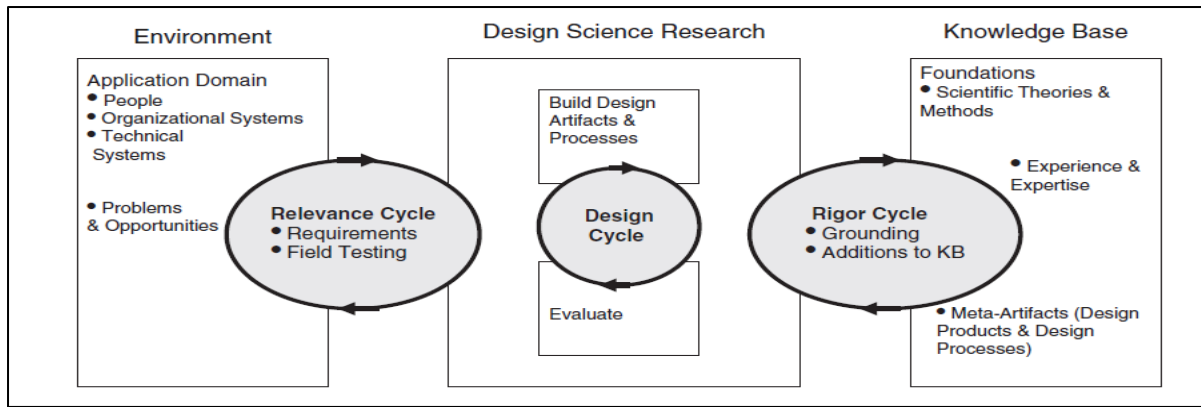

**Figure 3:** Relation of Design Science Cycles (Adikari *et al.*, 2009)

### 3.3 Relevance and Rigor Cycle

In this study, the relevance and rigor cycle principles were used to guide the process of gathering system requirements through identifying challenges present in the selected study area. This was achieved by collecting primary data and analyzing documented reviews as described in subsections below.

#### 3.3.1 Study Area

The research was conducted in the upper Pangani river basin located in the north east zone of Tanzania between latitude 3.3456° S and longitude 37.3464° E as shown in Fig. 4. The Pangani river basin is among the major river basins in Tanzania. It covers the area of about 43,650 square kilometres and is made of two main sources, Kikuletwa which originates from Mount Meru and Ruvu which come from the Lumi river in the Kilimanjaro region (Segers, 2018). The basin straddles in two countries, Tanzania (95%) and Kenya (5%) (Shaghude, 2015). In Tanzania, the basin falls over four administrative regions which are Manyara, Arusha, Kilimanjaro and Tanga whereby more than 3.7 million people depend on the basin for domestic and economic activities. Agriculture, fishing and livestock keeping are major sources of income for the people living along the basin. Moreover, the basin is used as a fundamental source of hydropower (8 MW) at the National level through Nyumba ya Mungu dam (Ngereza, 2005).

Population growth, industrial activities, urban growth and agriculture activities have intensified over exploitation of water resources, which have led to a decrease in both quantity and quality of water in the basin (Shaghude, 2015). A large part of the basin surface water is alkaline as characterized by low TDS ranging from 48 mg/L to 652 mg/L (Hellar-Kihampa, de Wael, Lugwisha & van Grieken, 2013). Also, low oxygen concentration has been a cause of concern

in some areas of the basin as it indicates the growth of algae caused by phosphorus (Brown *et al.*, 2010). Usually, the increase of phosphorus is due to disposal of industrial waste, private water treatment and decay of vegetation in water sources. In addition, the increase in the use of chemical fertilizers for agricultural activities has equally increased the amount of chemical compound (nitrogen, sulphates, phosphorous and nitrates) in basin (Selemani, Zhang, Muzuka & Njau, 2017). When it rains the chemicals are drained into the rivers and thus cause excess amount of chemicals in the basin. Furthermore, the effects of climate change might have led to decrease in the amount of rainfall during dry season, increase in the rainfall during wet season and increase in the amount of temperature in the basin. Therefore, these changes are likely to transform the entire characteristics of the basin (Hellar-Kihampa *et al.*, 2013).

Administratively, the basin is led by Pangani Basin Water Board (PBWB) which is responsible for managing water resources in the basin. In the role of monitoring water status of the basin, the board have installed a network of manual monitoring systems in some stations, which so far have been not able to provide regular and reliable information.

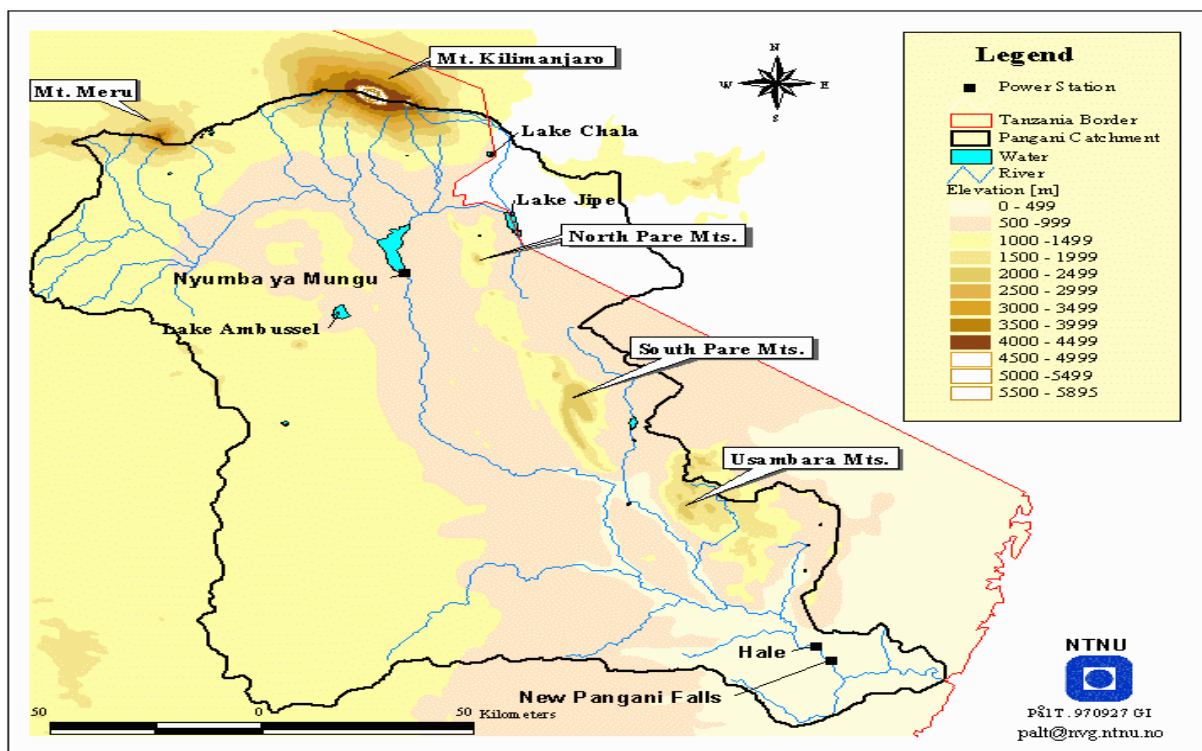

**Figure 4:** Map Showing Pangani River Basin (Palt, 2002)



### 3.3.2 Sampling Design

In this study, the sample was selected for the aim of identifying challenges encountered in using existing Water Quality Monitoring System (WQMS) in the Pangani basin. To achieve that, a non-probability purposive sampling technique was used to gather information from basin officials working in the Environmental department, Water Quality department, ICT department and Planning Department. Moreover, several institutional documents from the MoWI and annual basin reports from Pangani, Ruvu and Wami were used for getting information during the study. In addition, the research papers from Google scholar, Science direct and Elsevier websites covering the field of water quality monitoring, Hydrological, Hygiene and Environmental health were used to enrich information sources for the study.

**Table 2:** Number of Respondents in The Study Conducted in Pangani Water Basin

<b>Department</b>	<b>Respondent</b>
Environmental	14
Planning	6
Information and Communication Technology (ICT)	8
Water Quality department	10

### 3.3.3 Data Collection

In order to get sufficient and relevant information for designing the secure water quality monitoring system using remote sensors, a two-step data collection approach was employed. The first step focused on collecting existing information on water quality monitoring systems

and challenges encountered and the second step was to utilise the information obtained in step one to design and test the secure water quality monitoring system using remote sensors.

With regard to existing information on water quality monitoring systems and challenges encountered, the data was collected from the study area on 30<sup>th</sup> April and 7<sup>th</sup> May 2018. In doing so several data collection methods were employed including:

- (i) Personal Interviews whereby structured interview was used to ask face-to-face questions to officials, engineers and technical staff in Environmental department, Planning department, ICT department and Water Quality department. The interview focused on the official's experience on how they conduct the water quality monitoring and management operations.
- (ii) Questionnaire whereby self-administered questionnaire was prepared for officials of the basin who were not available for the interview. The questionnaire forms were left at the Pangani basin offices for other officials who were in the field during the interview period to fill in. The objective was to get sufficient number of people to provide information, for in-depth analysis of the challenges they face on the field during water monitoring activities.
- (iii) Content analysis whereby data was collected through extracting messages that related to studies of water quality monitoring and managements from different documentations. It involved use of books and research papers covering water quality monitoring, basin annual reports from the government institutions including MoWI, WBA and documentary videos on activities of the Pangani basin.

#### **3.3.4 Data Analysis**

Data analysis was achieved through the use a Qualitative Data Analysis (QDA) Lite Miner software. It is a qualitative software for coding textual and graphical, retrieving, annotating and reviewing coded data and documents. The software uses different analytical tools to identify patterns and relationships between codes and other properties (Provalis, 2018). In this study, the data collected from interviews, questionnaires and contextual analysis were imported to QDA Lite software and coded in the tree like structure (Provalis, 2018). The codes were divided into three categories which are water quality parameters measured in the river basins and its significance, causes of poor water quality in the rivers and challenges facing the existing water quality monitoring system. Thereafter, the coded results were retrieved using a textual analysis

module present in software whereby coding frequency submodule was used to provide the results in the form of charts and tables.

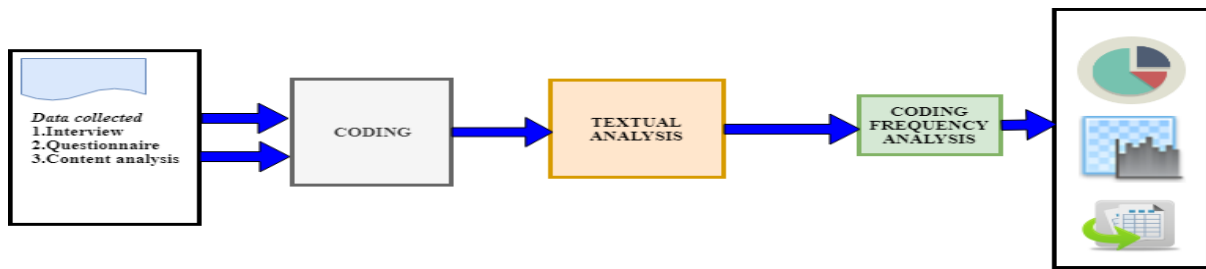

**Figure 5:** Workflow of QDA Lite Miner for Analysing Textual Data

### 3.4 Design Cycle

The design cycle on this study adopted four process lifecycles of Dynamic System Development Method (DSDM), which are system requirements analysis, functional model iteration, design and build and implementation. Dynamic System Development Method is a rapid application development method for dynamic information systems which is designed to eliminate large cost, poor quality and delay of the product deliver. The choice of using the DSDM in this study based on the following reasons: it emphasizes on the collaboration between users and developer, the entire development of system is driven by user needs and incremental and it encourages regular delivery and testing of working software (Voigt, 2004).

#### 3.4.1 System Modelling

In the development of the ISWQMSRS, modelling was used to represent the functions of the process while reducing complexity of the descriptions. Processes involved in the system development was analyzed in terms of how it works, interact with other processes and produce the required output. In this study the methods used in system modelling are as follows:

- (i) Circuit diagram is the pictorial representation of electric/electronic circuit. It shows how different electronic components are connected electrically. In this study, the circuit diagram was used during the design of a data acquisition unit or sensing unit which involve sensors, controller and analog to digital converter boards with different electrical characteristics. The circuit diagrams were designed using an orcad-capture software. The choice of using the orcad-capture software is based on the facts that, it is the most widely used electronic software for making schematic diagrams with large number of supporting libraries, it has large online support and highly supports engineering process design (Cadence, 2018).

- (ii) Flow chart is the representation of the algorithms in the form of pictorial diagrams whereby steps are presented in shapes while logical flows are presented by arrows (Granfelt, 2017). In this study, the flowchart diagrams were mainly used to design decision algorithms, which were used during reading and transfer of sensor data over the network but also during analysis of sensor information to check if they adhere to predefined standard values.
- (iii) Use case diagram is the description of system operations from the user point of view. It is used to show diagrammatically how system actors interact with system to achieve functional requirements. The decision to adopt the use case diagram as a design method in this study was prompted the facts that: it helps to ensure that the system functional requirements are captured correctly, it is easy to understand and can be used to communicates easily with system users, it is used to provide a verification for higher system models and validation of system requirements, it is used to manage complex applications and provide timing requirements for real-time applications (Firesmith, 2014).
- (iv) Data Flow Diagram is the method of representing the logic underlying the system. It shows the movement of data from the source to process and to data storage. The main purpose of using the DFD to the proposed system was to model the inter relationships between systems and sub systems.

### **3.5 System Implementation**

In this section we present methods used for the development of innovative secure water quality monitoring system. It includes the methods used for sensor selection, web application development using django model view controller, database management systems, pycharm editor and template development as presented in the following subsections:

#### **3.5.1 Sensor Selection Method**

The selection of sensors for development of a Data Acquisition Unit (DAU) for the proposed system was achieved by using seven steps: identification of the sensing target by considering system requirements and information to be sensed, determination of viewpoint of sensing target which is achieved through analyzing the suitable way to get sensing information from the human sense perspectives, identification of a list of possible sensors to be used for system development by considering sensor type and physics behind it, identification of the sensor

detection level when compared to a real physical phenomenon, examination of sensor conditions when compared to the system requirements, listing sensor's constraints and selection of the qualified sensors to be used for developing the system .

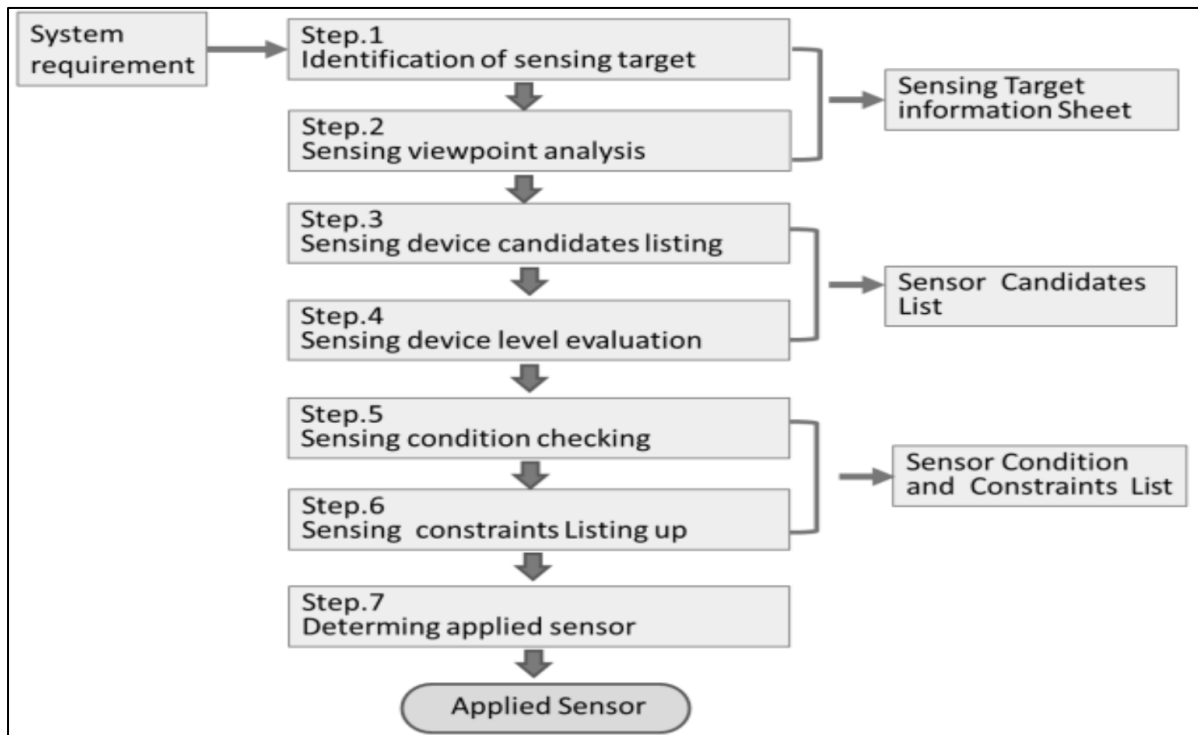

**Figure 6:** Flow of Sensor Selection Method (Hirayama, 2016)

### 3.5.2 Django Model View Controller

The web application was designed to ensure it provides data visualization, decision support, user authentication and data storage. To achieve that, both user and server-side applications were developed using django 2.0.5 framework. A django framework is a free python web framework which uses Model View Controller (MVC) approach to develop a web application in a fast, secured and easy way (Amballi & Mahanta, 2018). It is designed in such a way that it reduces module complexity, facilitate code reuse and easy application maintenance. Like other MVC framework, django comprises of three main layers, which are view, model and controller layers. The controller layer is used for processing the logic, which originates from the user request and providing the response accordingly. The model layer is used for organising and manipulating data used by an application. The view layer is used for rendering the information from user's requests in the web page (Zhang, Wei & Yang, 2013). The choice of using django mvc over flask and pyramid was due to the following reasons: its flexible usage

for both large and small application, in-built function for routing, database administration, templating and authentication and it has numerous plugins and libraries which are suitable for web application system developments in a fast-paced environment (Plekhanova, 2009).

### **3.5.3 JetBrains PyCharm Editor**

During development phase of the ISWQMSRS the JetBrains PyCharm editor was used as a platform for writing codes. The JetBrains PyCharm editor is a software for developing Python applications. As among the leading editor in developing enterprise applications, JetBrains PyCharm editor brings so many benefits when compared to traditional editor due to the following factors: it saves development time since it is fast in automating tasks and debugging, it has auto suggestion services for program library packages and program variables and it has large online support from the system developers. In addition, it is compatible with Django framework thus making it easier to use (Karen, 2015). Therefore, the aforementioned factors lead to the selection of JetBrains PyCharm editor as a code editor for system development.

### **3.5.4 MySQL Database**

MySQL is an open source relational database management system that uses standard structured query language for data definition and manipulation (Letkowski, 2014). The choice of using MySQL was due to the following reasons: it is free and runs on many platforms including Windows, Linux and others, it is easy to customize, it has large technical support and easily to operate and support large size database (Letkowski, 2014).

### **3.5.5 Hypertext Markup Language, Cascading Style Sheet and Java Script**

Hypertext Markup Language, Cascading Style Sheet and JavaScript are standard languages for making both dynamic and static web applications (Srikanth, 2014). In this study, these markup languages were used for making graphical user interfaces for the ISWQMSRS.

## **3.6 System Testing and Validation**

In this section methods used for testing and validation of ISWQMSRS were presented. Both simulation and white and black box methods were adopted to ensure the developed system adheres to requirements as presented in the next subsections.

### **3.6.1 MATLAB Simulink**

Simulink is a software developed by MathWorks to simulate, model and analyzing dynamic systems (Abu-aisheh, 2014). It uses block diagrams with defined mathematical functions to produce system outputs. In this study, the Simulink software was used to simulate sensor responses when subjected into different variables and conditions using mathematical equation defined from sensor manufactures. Selection of the Simulink for simulating the sensing unit was based on the following factors: it contains libraries for supporting multiple systems, it is easy to use and highly accurate, it can be used to model simple and complex system and it supports modelling and design of systems using both block diagrams and coding (MathWorks, 2018).

### **3.6.2 White Box and Black Box Testing**

Both white box and black box testing technique were used for validating the system functionalities against the system requirements (Nidhra & Dondeti, 2012). In black box the software was tested to check if it worked according to the functional requirements, while in the white box the focus was to check if the algorithms were structured in the logical order to produce intended output. In this study, the testing the ISWQMSRS was done in the following order: unit testing which involved testing each module if it provides the desired, integration testing was done to test interaction between modules developed in the system, performance testing was done to check performance of each module was tested and analyzed to assess if it worked according to the system requirements. We used performance testing to determine the speed, latency and stability of the developed application.

## **CHAPTER FOUR**

### **RESULTS AND DISCUSSION**

#### **4.1 Introduction**

This chapter presents the findings and discusses the results obtained from study. In addition, it presents the results of the design and implementation of Innovative Secure Water Quality Monitoring Systems using Remote Sensors. Further, the results obtained from simulation and testing system are presented and discussed.

#### **4.2 Results and Discussions from Study Area and Related Document Review**

In a bid to understand the existing water quality monitoring systems and identify the essential components for proper interventions and preservation of water sources, interview with Pangani river basin officials was conducted. The key information solicited comprised of water quality parameters that are measured, causes of Pangani river water pollution and existing challenges in water quality monitoring system.

##### **4.2.1 Water Quality Parameters Monitored in Pangani River Basin**

With regard to water quality parameters that are mostly measured in the Pangani river basin and the reasons for the same, the study found out that 48.1% of all measurements collected from Pangani River basin involve physical water quality parameters including, pH, K, TURB and DO. Measurements on chemical water parameters such as BOD, COD, Phosphorus (P) and Sodium (Na) accounted for 34.6% of all measurements. The remaining 17.3% involved measurement of biological water quality parameters such as TC, CH and organic nutrients as shown in Fig. 7.

The high percentage of physical water quality parameters when compared with others could be due to availability of measuring equipment called Wagtech Maji-meter. The equipment is extensively used by water quality engineers to determine the quality of water in various stations along the basin. In addition, the study revealed that, in monitoring water quality parameters high priority was given to physical water parameters because the parameters have fast response during monitoring, the entire process of measuring physical water parameters is easy, accurate and these parameters are generally used as indicator of performance for both chemical and biological water quality parameters. Similar reasons were reported by the environmental flow assessment report in Ruvu river basin (GLOWS-FIU, 2014). On the other hand, both chemical



and biological water quality parameters measurements indicated low percentage 34.6% and 17.3% respectively because the process of monitoring these parameters appeared long and complex due to the fact that, all samples collected were to be taken to special labs located in Moshi. Other special measurements were taken to laboratories found only in Dar es Salaam for analysis.

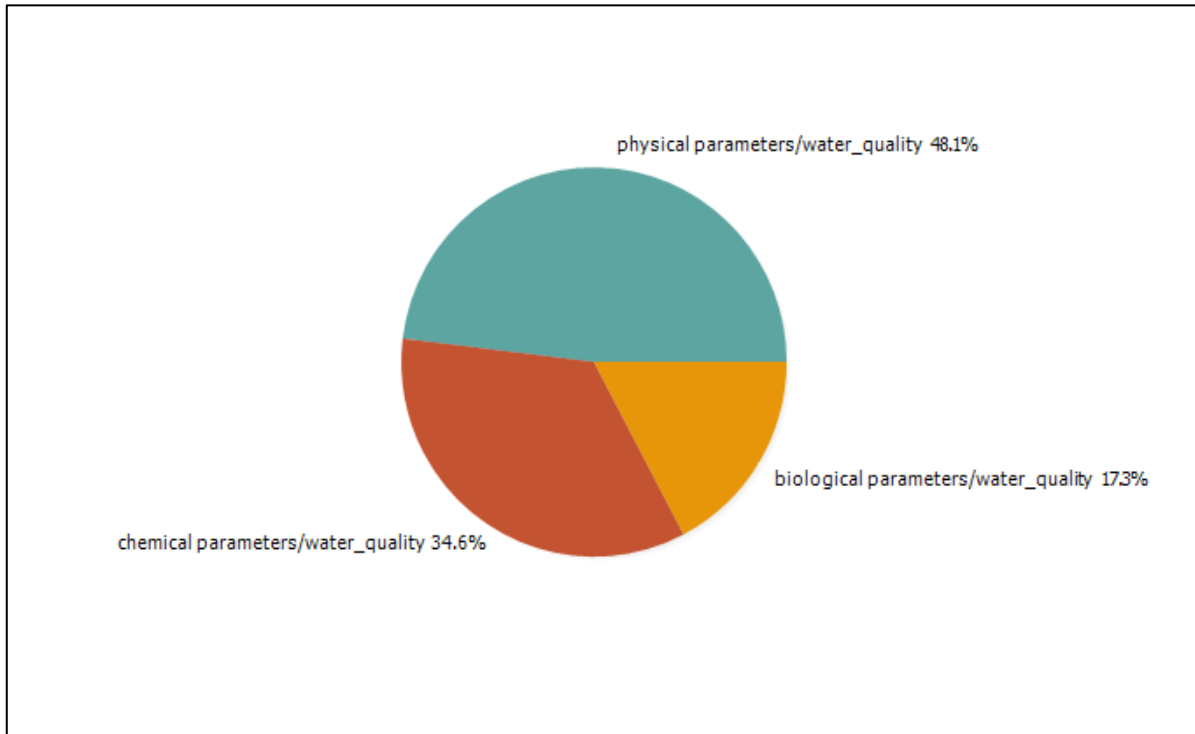

**Figure 7:** Distribution of Water Quality Parameters as Monitored in Pangani Basin

#### **4.2.2 Assessments of Causes of Water Pollution in Pangani River Basin**

Regarding the causes of pollution of water within the upper Pangani river basin, the study found out that industrial and construction wastes contributed to 35.5% of all water pollution factors in the basin. The reasons could be due to discharge of waste water in the water sources by the manufacturing industries located nearby the river basin. Industrial waste water tends to contain toxic chemicals, some of which being harmful to humans and other living organisms depending on that water source. In addition, the study has revealed that agricultural activities contribute 29% of all factors causing water pollution in the basin. Generally, majority of the people living in the basin and other surrounding areas depend on agriculture for food and business activities. Hence, during dry seasons farmers continue cultivating their crops using nearby water sources through irrigation and also by using wetland residual moisture to maximize their production. In undertaking the farming activities and chemical fertilizers are mostly used to enhance

productivity. Therefore, during the rain seasons these chemicals fertilizers are washed away and eventually ending up polluting the water sources.

Furthermore, the information collected from the Pangani river basin staff indicated that population growth contributes 22.6% of the water pollution factors. The increase in population also increases economic activities such as industrial, construction and agriculture all them contributing to water pollution. Further analysis of information from Pangani river basin staffs and related documents indicated that climate change contributes 12.9% of water pollution factors. In some cases the influence of climate change results in increase in the amount of rainfall in the basin, which also results to floods and soil erosion in the basin, thereby causing water pollution.

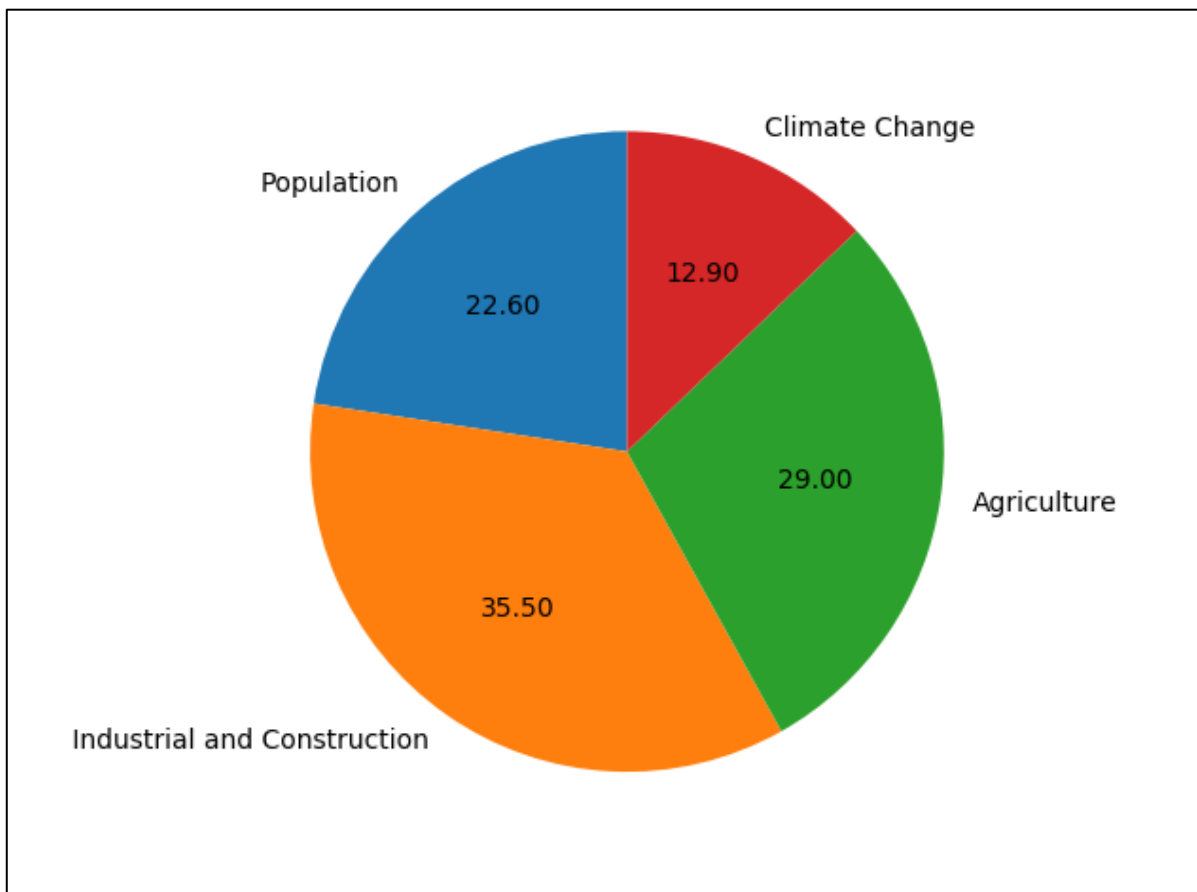

**Figure 8:** Causes of Water Pollution in River Basin

#### **4.2.3 Challenges of Existing Water Quality Monitoring System in The Pangani Basin**

Information aggregated from the Pangani river basin staffs and documentations regarding the challenges facing water quality monitoring system revealed that, manual methods and

processes of monitoring and managing water quality are the major challenges because they are inefficient and time consuming. Figure 9 provides percentage of respondents regarding specific challenges of the manual methods of water quality monitoring system including:

- (i) Time consuming (100%), because measurements involve collecting water samples from the field areas (water stations) and taking them to the laboratory or to some water stations that have Wagtech Maji meter equipment.
- (ii) Costly (73%), because every time field measurements are to be conducted, the basin authorities must prepare a team of water quality engineers including allowances, equipment maintenance costs and laboratory chemicals.
- (iii) Not reliable (82%), because the measurements of water quality in the river basin are taken only three times in a year (quarterly). In this case the total number of measurements obtained are not enough to provide sufficient information of the status of water quality in the basin.
- (iv) Measurements processes need trained personnel (100%) for operating equipment such as data loggers, Wagtech Maji meter and proper analysis of water samples in the laboratory for accurate results.
- (v) Lack of confidentiality of data collected (64%) from measurement activities. While unauthorised use of water measurement data is legally prohibited the same are stored in the manual books and files.
- (vi) Insufficiency measurements (45%) since the data is collected only three times in the year, therefore cannot provide enough information for planning and evaluation decision making purposes.
- (vii) Lack of power sources (9%) in the water stations due to absence of electricity and solar power in water stations.

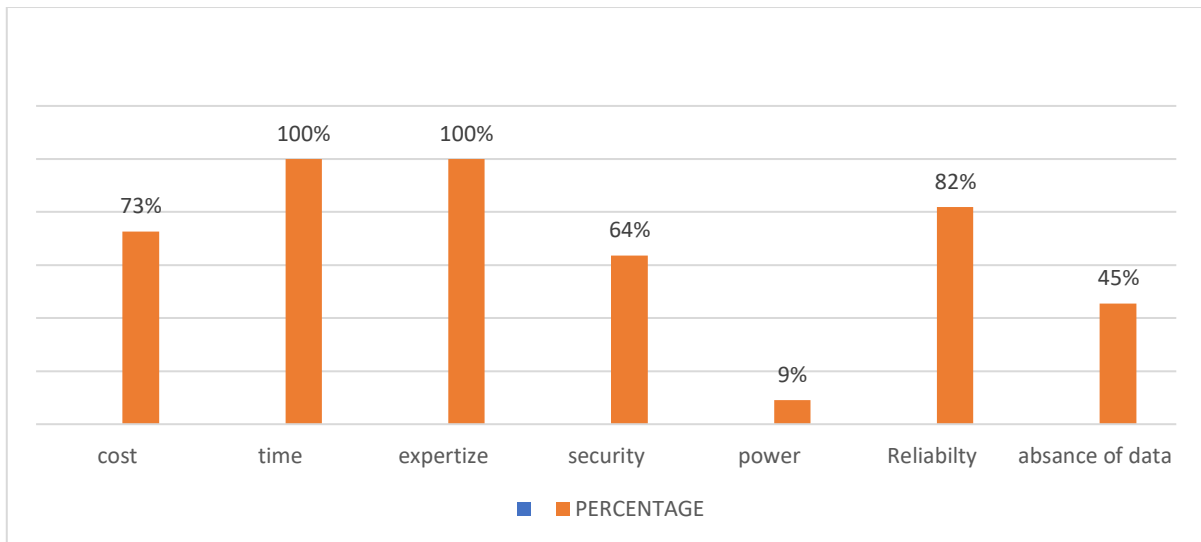

**Figure 9:** Assessment of Challenges in Monitoring Water Quality in Pangani River Basin

### **4.3 Design of An Innovative Water Quality Data Monitoring System For The River Basin**

Before the system design, the data collected from interviews, questionnaires and document review were used as a key factor in describing clearly services and constraints that should be enclosed in the system. To achieve this, both services and constraints were divided into functional and non-functional requirements.

#### **4.3.1 Functional and Non-functional Requirements**

A functional requirement is defined as the functions that the system must be able to perform without considering physical constraints (Alsaleh & Haron, 2016). It describes input and output behaviour of the system. Non-Functional Requirements is defined as the properties in which the end product the system must possess and describes non-behaviour property of the system (Alsaleh & Haron, 2016). In this study, there are seven functional requirement of the system and five non-functional requirements. Table 3 provides a description of the functional requirement and non-functional requirements used in the system design.

**Table 3: Functional Requirements**

<b>Functional Requirements</b>	<b>Description</b>
The system shall monitor automatically pH, TURB, DO and TEMP.	The data required by the users of the system should be real-time and updated
Only basin officials are required to login into the system.	The system should be used only by registered officials from the Pangani Water Basin Authority
The system shall display data in graphical form.	The system shall provide data in graphical format: pH (y-axis) vs time (x-axis), Turbidity (y-axis) vs time (x-axis), DO (y-axis) vs time (x-axis), Temperature (y-axis) vs time (x-axis).
The system shall display data in tabular form and tabular form.	The system shall provide data in tabular format with the inclusion of the following attributes: site name, site ID, sensor ID, location, pH, TURB, DO and TEMP, time and date.
The system shall calculate the average values of measured parameters and display the results after a specified time	The system shall calculate the average values of pH, TEMP DO and TURB and display the results.
The system shall redistribute information timely to specified officers once parameters exceeded a standard value.	The system shall send alert SMS to officers when sensors detect that the accepted values of either pH, TURB, DO or TEMP have been violated.
Add staffs, departments and stations	The system administrator registers staffs, departments, stations and users into the system.

**Table 4:** Non-Functional Requirements

<b>Non-Functional Requirements</b>	<b>Description</b>
Security	The system shall be secure since the measurements taken in the stations are only required to be disclosed by MoWI, which is responsible for the sector. Moreover, only authorized users are permitted to access and use the system
Accessibility	The system shall be accessed at any time. Since the system will be installed in remote places that are basically far from the central offices, then the use of a mobile network for communication and transmission of data is required. Incorporation of mobile network in the design considered high penetration of mobile network in remote places.
Usability, Reliability and Portability	Users with different levels of computer literacy shall be able to operate easily the proposed system. Therefore, both user interfaces and system operation have been designed in such a way that users with different levels of computer literacy shall be able to operate easily the proposed system. Therefore, both user interfaces and system operation shall be designed in such a way that it can be manipulated easily by its users.

### 4.3.2 System Modelling

The design of an innovative secure water quality monitoring system using remote sensors relied upon the following principles: low cost, scalability, security, efficient, availability and easy to

use. Low cost element has been achieved through use of cheap sensing unit devices for measuring the status of water quality in the basin. Scalability stand for the ability of the system to store and retrieve the sensor measurements at any time. Security account for the ability of the system to provide confidentiality, integrity and availability of the information transferred and stored in the database server. Efficient accounts for the ability of the system to provide the intended output with low power, energy and time. Availability stands for the quality of the system to be obtained at any time when needed while usability accounts for ability to be operated easily by its users.

### **4.3.3 System Design Architecture**

The system design architecture consists of a remote sensor unit and web application system. The description of system conceptual design and block diagram is presented below.

#### **(i) Conceptual System's Framework**

In addressing the challenges facing the Pangani river basin staffs in using the existing water quality monitoring systems, including high cost of running monitoring activities, lack of expertise, absence of quality data, security and reliability of the information collected and time. The study envisaged the use of IoT architecture to eliminate the mentioned challenges. In view the above, the design of an ISWQMSRS conceptualized the following four stages:

- (i) Sensor devices be installed in the river basin areas to monitor water quality parameters which includes pH, TURB, DO and TEMP. Information collected will be processed and secured through the use of controller.
- (ii) All the information processed in the first stage be transferred through the use of cellular network communication, which is accessible in the large part of the Pangani basin office for processing and storage.
- (iii) Pangani basin officials'ability to monitor, view, analyse and receive notification messages on the status of water quality in the river basin through the use of a web application and SMS services.
- (iv) Data collected from sensor nodes be stored in the database present in the Pangani basin office for further processing and decision making.

Figure 10 presents a conceptual frame work for the Innovative Secure Water Quality Monitoring System using Remote Sensors.

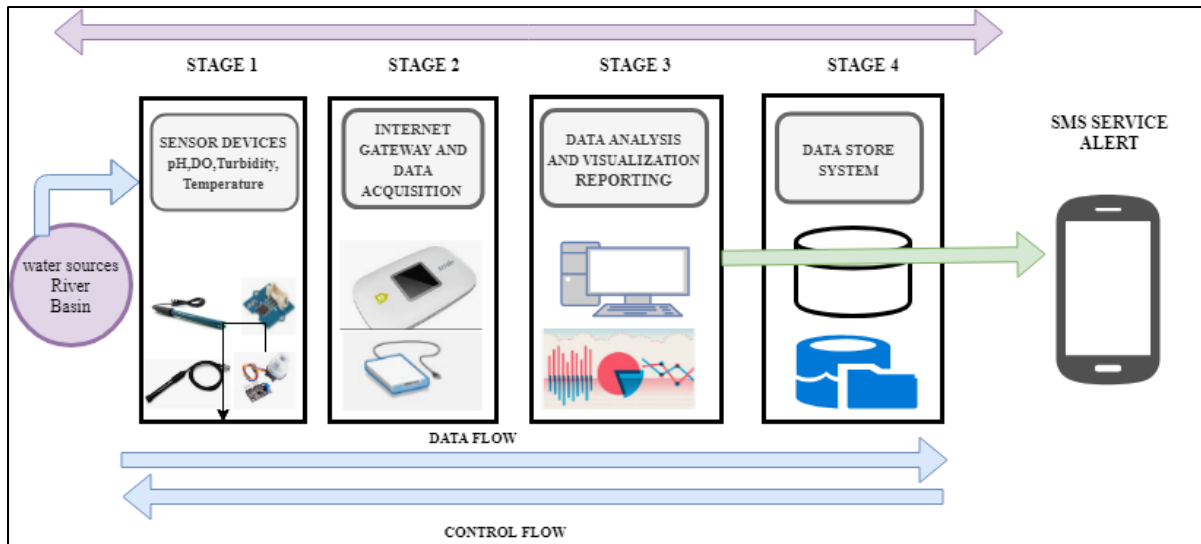
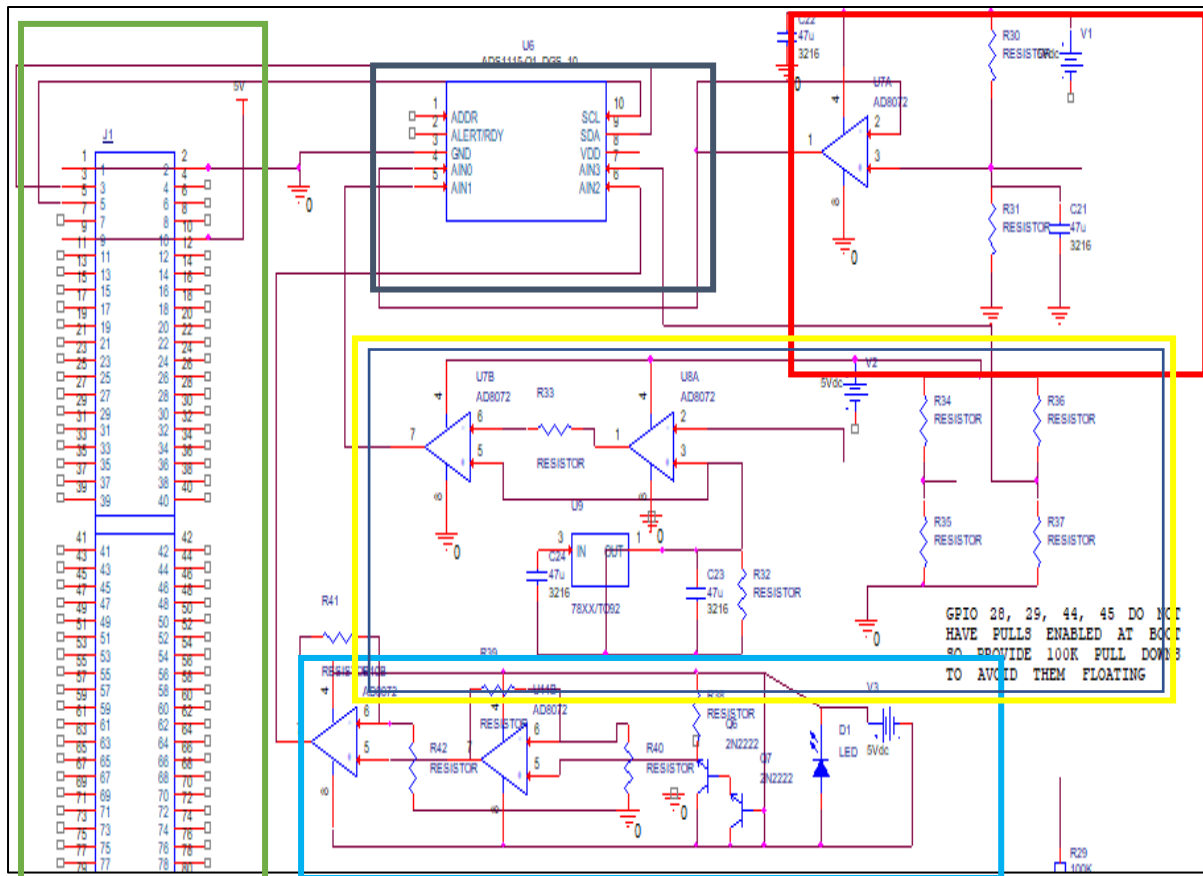

**Figure 10:** Conceptual Design Framework

**(ii) Circuit Diagram Design**

During design of the ISWQMSRS, the circuit diagram was used to describe the way components are electrically connected. The circuit diagram was made of single board computer enclosed in the green rectangle, ADS1115 converter enclosed in dark blue rectangle, pH sensor enclosed in red rectangle, TURB sensor enclosed in light-blue rectangle, DO enclosed in a yellow rectangle and TEMP sensor enclosed in black rectangle as shown in Fig. 11. The circuit was designed to use 5 VDC supply voltage for each electronic component in the circuit. It also uses an Inter Integrated Communication Protocol (I2C) to connect sensor devices and controller unit. Therefore, single board computer used pin 3 and pin 5 for SCL and SDA respectively to transfer and receive data from the ADC components. The analog to digital converter components consisted of four channels (AIN0, AIN1, AIN2 and AIN3), which received analogy signals from sensors outputs and converted them to digital signals. The digital signals were transferred to single board computer through I2C protocol.





**Figure 11:** Circuit Diagram for Data Sensing Unit

### (iii) Use Case Diagram

To appreciate the importance of following software engineering principles, the use case for the ISWQMSRS was designed using the Visual Paradigm UML 10.0 software. To achieve that, the resulting use case diagram passed into three stages of design. The first stage was to define the main system components of the use case diagram whereby components like actors, relationship (associations, extend, include and generalization), system boundaries and use case were described. The second stage was to draw the use case diagram and the final stage was to provide the description the way each actor interacts with the use case.

#### *Use Case Components*

Use case diagram is the description of system operations from the user's side. It diagrammatically show how system actors interact with system to achieve functional requirements (Firesmith, 2014). Table 5 provides the descriptions of various components of the use case which were used during development of ISWQMSRS.

**Table 5:** Use Case Components

<b>Component</b>	<b>Descriptions</b>
System boundary	It is presented as a rectangle whereby it is used to differentiate internal and external environmental of the system
Relationship	Association: a line showing relationship between user and system  Extends: one use case indirectly incorporates the behaviour of another Use case at a certain point in time. Include: Insert other actions into base use case and Generalization: is the relationship between general case and specific use case
Actors	Includes human, automated system which has ability to interact with the system.
Use Case	The sequence of actions taken by users to get the required target.

Figure 12 shows the use case diagram used in design of the ISWQMSRS web application system. The system has three actors named: basin officials, information and communication administrator and sensor nodes.

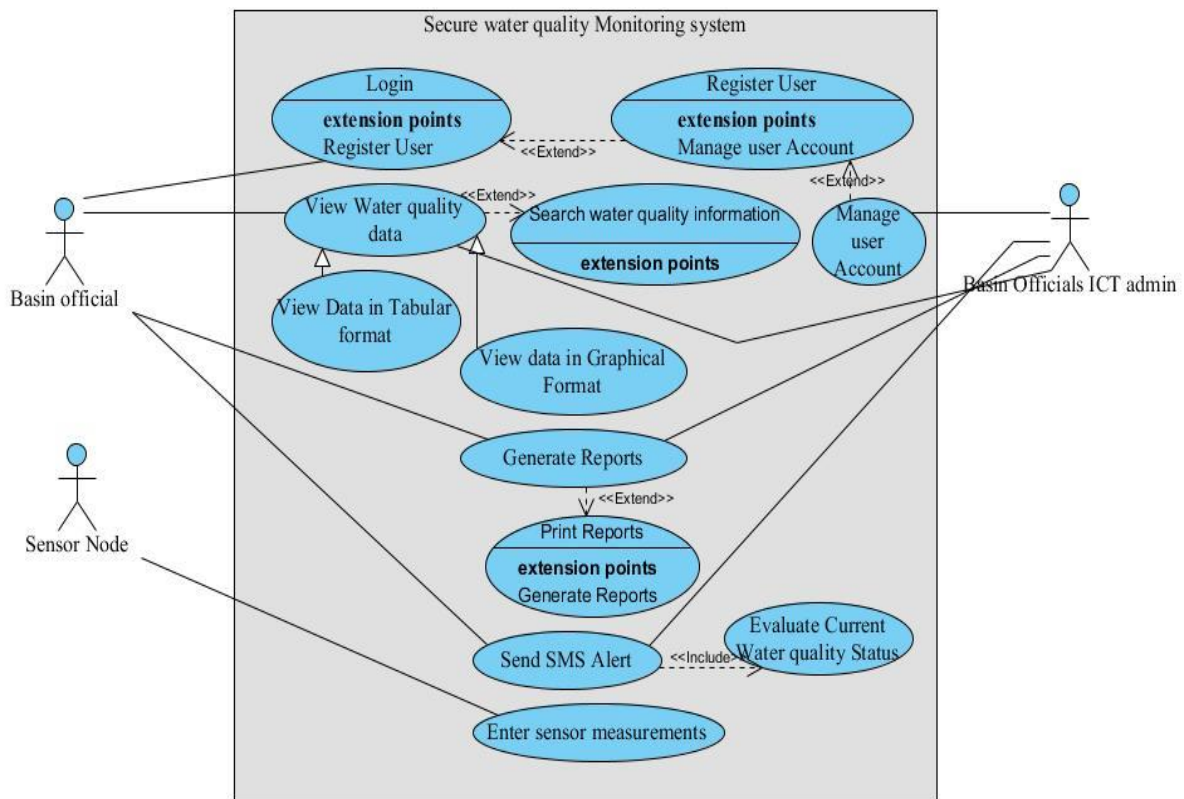

**Figure 12:** Use Case Diagram for ISWQMSRS

In order to properly construe the functioning of the ISWQMSRS, each use case is described in the following sub-sections.

***Manage Accounts (Register User and Login)***

The ISWQMSRS system allows only basin information and communication system administrator to register system users while the registered users (in this case basin officials only) to login in the system. This control ensures authentication and monitoring of systems to be executed by basin officials only.

***View of Water Quality Information and Reporting***

Through a view and water quality information use case, basin officials and basin information and communication technology administrator can view real-time information of water quality from the basin, both in tabular and graphical format and hence generate reports summaries from the system.

### ***Input Sensor Measurements***

The system receives sensor information from sensor nodes and decrypting them through the AES module developed in the system.

### ***Send SMS***

Apart from viewing water quality status in basin, the system sends SMS to the basin officials once the water quality parameters in the basin exceed the pre-defined standard values.

### **(iv) Data Flow Diagram (DFD)**

Figure 13 presents, the DFD that was effectively used in the design of the ISWQMSRS system for enhancing communication between user requirements and system development. It was also a foundation for developing the ISWQMSRS system, which is used to manage and monitor water quality in the Pangani river basin.

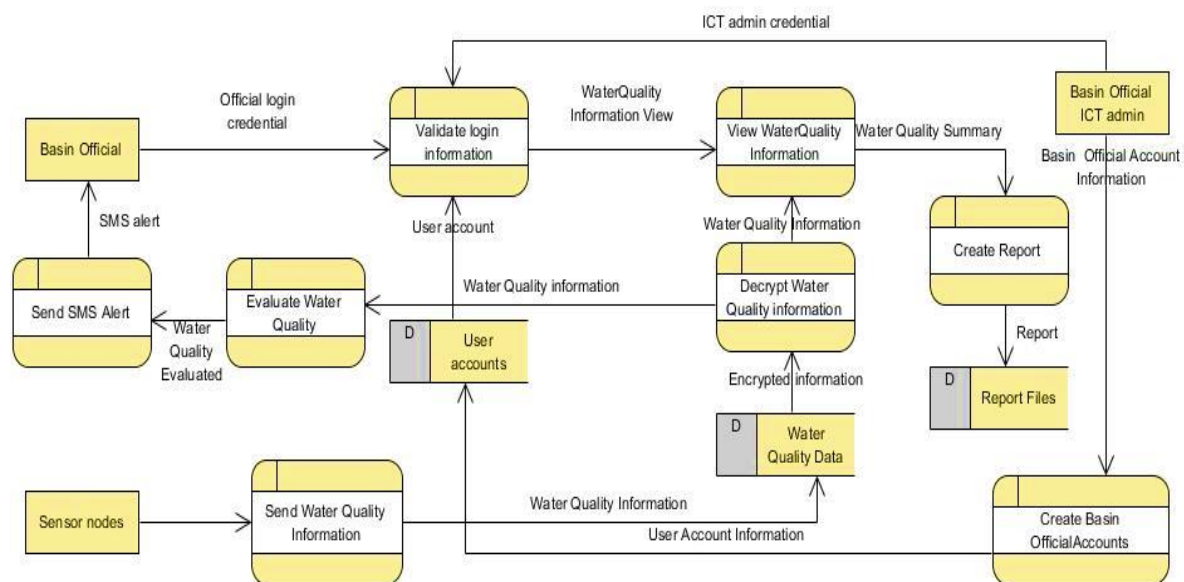

**Figure 13:** Data Flow Diagram for Innovative Secure Water Quality Monitoring System Using Remote Sensor.

The system receives data from remote sensor nodes in the form of cipher text whereby it decrypts the received information into plaintext using AES. The decrypted information is then processed for visualization by registered basin officials. The system allows basin information and communication technology administrator to manage user accounts and overall system operation in the basin. On the other hand, basin officials will be able to receive real time

information regarding status of water quality, generate report of water quality status and receive SMS once the quality of water is beyond predefined standards values.

**(v) Block Diagram Architecture**

The block diagram architecture design of the ISWQMSRS adopted the IoT architecture the way it store and manage information. Therefore, this system consisted of three layers of architecture design. The lower layer was made up of four sensor devices for pH, TURB, TEMP and DO parameters taking respectively. The lower layer also consisted of a single board computer unit and analog to digital converter for digital signal processing. The middle layer was made up of wireless network module, which was responsible for connecting sensor nodes with internet to allow transfer of data from single board computer unit to a remote database. The upper layer was made up applications software for visualizing real-time water quality data, generating water quality status reports, providing alerts in the case of poor water quality in the basin and ensured storage and security of data. Figure 14 presents block diagram architecture for the innovative secure water quality monitoring using remote sensor.

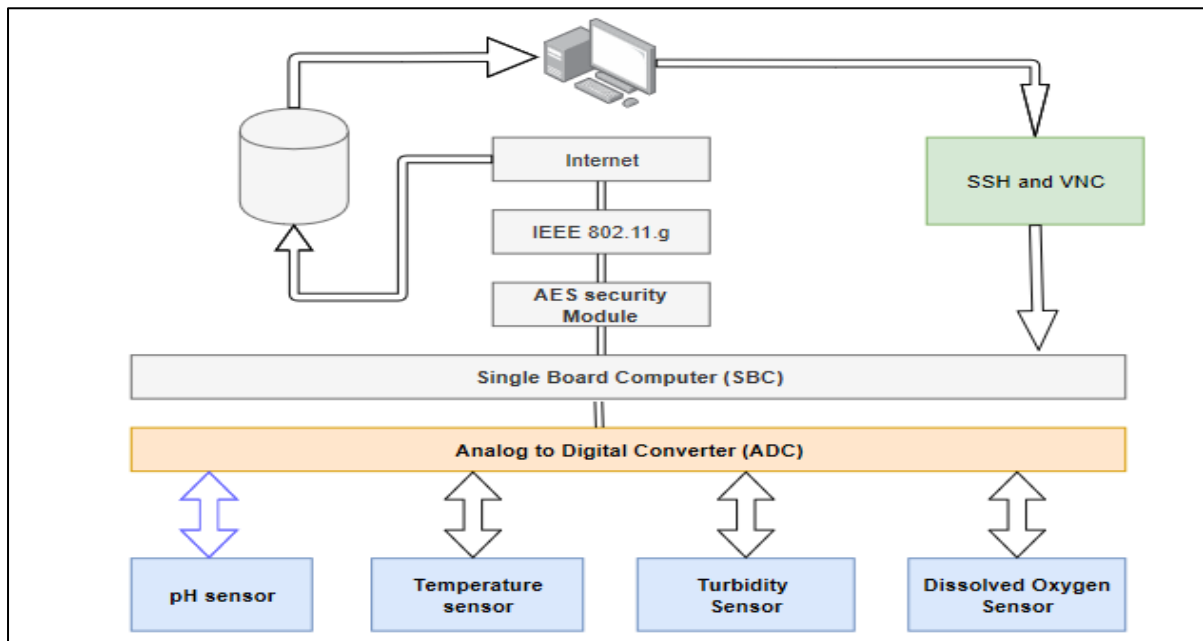

**Figure 14:** Block Diagram Architecture for Innovative Secure Water Quality Monitoring Using Remote Sensor.

#### **(vi) Selection of Sensing Unit Components For Development of ISWQMSRS**

In order to achieve proper functioning of the ISWQMSRS, a variety of sensors were carefully chosen. As shown in Fig. 14, the sensing unit, which is responsible for the collection of water quality measurements from water source /water sites and sends them to central office system is located on the lower layer of the block diagram architecture. Therefore, the choice of sensing unit components that includes sensors, single board computer and analog to digital converter board was based on sensor-selection method described in the methodology section.

In the first phase of sensing unit design, the sensors were identified and assessed for its capability to sense specified target. In the second phase, the sensing components were evaluated for their level of performance. In the last phase, the conditions and constraints of sensors were evaluated. Hence, a total of seven sensors (motes), three single board computers and three wireless modules were identified as candidates for selection as shown in Table 6 and Table 7.

**Table 6:** Candidate Sensors' Specifications

<b>Device Category</b>	<b>Device type / Device model</b>	<b>Accuracy</b>	<b>Sensing limit</b>	<b>Operating Voltage</b>
Physical degree sensor	pH sensor/ SIN-PH6010-ae14	±0.1	0-14	5V
Physical degree sensor	pH sensor/ SKU: SEN061	±0.1	0-14	5V
Physical degree sensor	Dissolved Oxygen sensor/ SKU: SEN0237-A	Not specified	0-20 mg/l	3.3-5V
Physical degree sensor	Dissolved Oxygen sensor/ EZO-DO	±0.05	0.01-100mgL	3.3-5V
Physical degree sensor	Temperature Sensor/ TMP100-SKU: TOY0045	±2	-55-125 °c	3.3-5V
Physical degree sensor	Temperature Sensor/ Grove Temperature V1.2	±1.5	-40°C-+125°C	3.3—5V
Physical degree sensor	Turbidity sensor/ SKU: SEN0189	Not specified	5°C-90 °C	5V

**Table 7:** List of Identified Single Board Computers

<b>Model</b>	<b>Raspberry Pi 3 model B</b>	<b>Nucleo-F410re</b>	<b>ODROID-XU4</b>
Power	5V,3.3V,2A (grid and battery)	5V, 800mA	5V,4A
Microcontroller	ARM quad-core	STM-32-ARM	Samsung Cortex
Cost	Low cost	Low cost	High cost
Memory	1GB	512KB	2GB
Support	High	Low	Low

Following identification of candidate sensors, datasheet was used to assess their conditions and constraints so as to finally select the proper sensors for system development as shown in Table 8. The selected sensors were procured for design of the ISWQMSRS.



**Table 8:** Sensing Condition and Constraints For Identified Sensors

<b>Model</b>	<b>Sensing type Data</b>	<b>Response Time</b>	<b>Limitation</b>	<b>cost</b>	<b>support</b>	<b>Availability</b>
SIN- PH6010- ae14	Analog	Not specified	corrosion	Low	Low	High
SKU: SEN061	Analog	1min	No corrosion	Low	High	High
SKU: SEN0237- A	Analog	90s	0-50PS	High	Low	Low
EZO-DO	Analog/Digital	1s	Any pressure	Medi um	High	High
TMP100	Analog	Not specified	TEMP > 125°C	Low	High	High
Grove TEMP	Analog/Digital	Not specified	TEMP > 125°C	Low	High	High
SKU: SEN0189	Analog/Digital	500ms	maintenanc e	Low	High	High

## 4.4 System Implementation

### 4.4.1 Selection of Sensor Components for Development Data Acquisition

In the previous section, the list of candidate sensor for development of the ISWQMSRS was identified. Furthermore, the conditions and constraints of each sensing components was listed and analysed. Therefore, this section describes qualities of each selected sensor that was used for the development of the data acquisition.

### (i) pH Sensor Module

SKU: SEN0161 shown in Fig.15 is an analog pH sensor module with high response time (1 min) and a capacity to measure pH in all range (0-14). The SKU: SEN0161 sensor provides the output with high accuracy of  $\pm 0.1$  pH and operates with an input voltage of 5 VDC hence it can be easily integrated with both Raspberry Pi 3 model B and ADS1115 boards (DFRobot, 2018). Moreover, it has low-cost with a vast technical support and freely available on the internet. Therefore, it from the aforementioned factors led to the selection of SKU: SEN0161 for the prototype development.

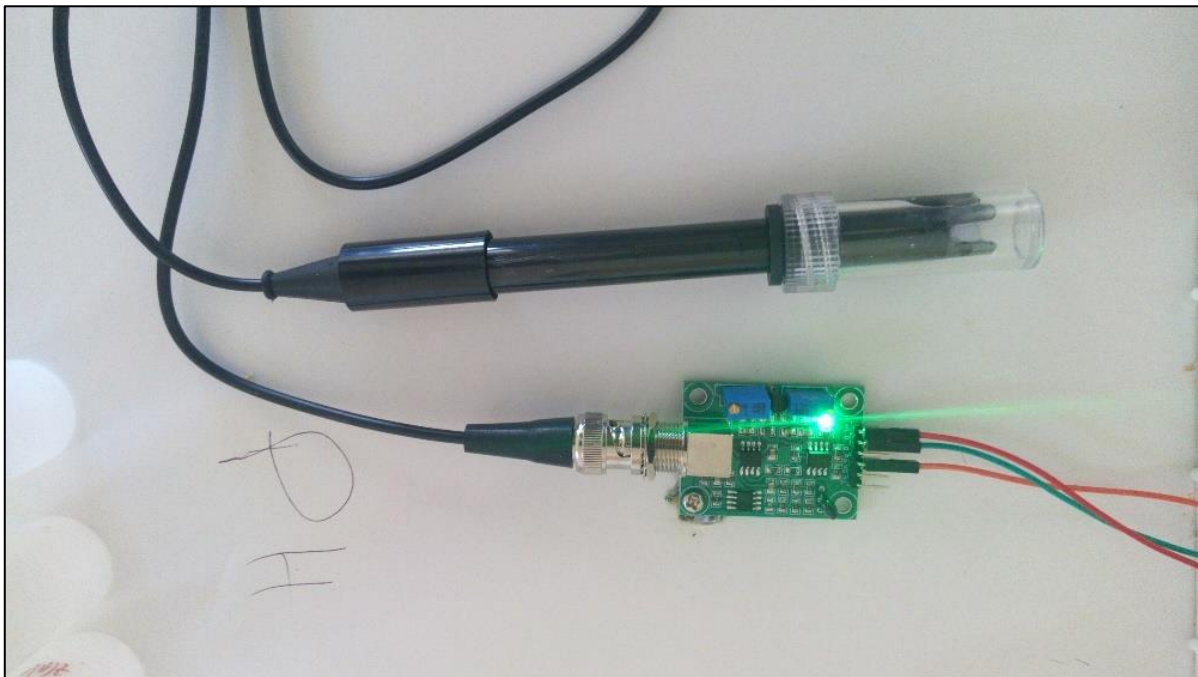

**Figure 15:** pH Sensor Module

### (ii) Turbidity Sensor Module

Figure 16 provides a picture of the SKU: SEN0189 turbidity sensor module. The SKU: SEN0189 is an analog/digital turbidity sensor module, which uses nephelometric principle to measure turbidity of water and provide output with high accuracy and high response time (500 ms) (DFRobot, 2018). It expresses the measurements results in terms of NTU and it has the ability to operate in the temperature range of 5 °C - 90 °C. In addition, the SKU: SEN0189 sensor uses 5 VDC and 40 mA input voltage and input current respectively for its operations. It is less expensive and easily available in the market (DFRobot, 2018). It is all these factors led to the choice of SKU: SEN0189 for the prototype development.

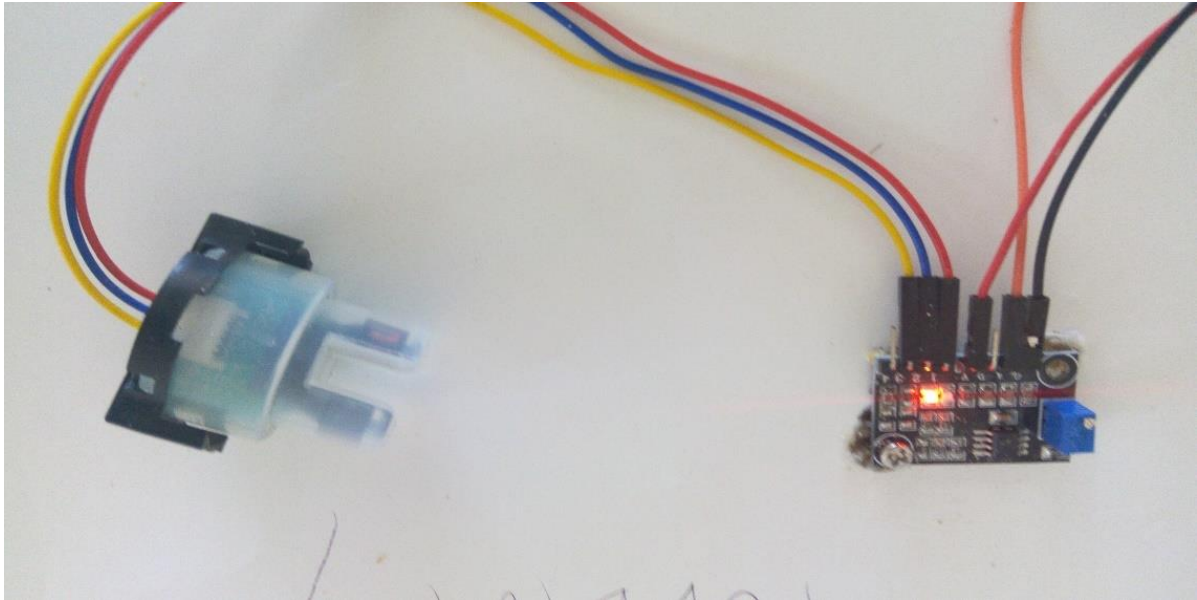

**Figure 16:** Turbidity Sensor Module

**(iii) Dissolved Oxygen Sensor Module (EZO-DO)**

The EZO-DO is a family of Atlas sensors for measuring dissolved oxygen in water. It uses a probe which contains polytetrafluoroethylene membrane, cathode and anode, whereby oxygen molecules are diffused into membrane and measured (Atlas, 2018). It is a well-calibrated sensor and provides output measurements with high accuracy of about  $\pm 0.05$  mg/L. It has a response time of one second and a capacity to measure a range of 0.01-100 mg/L amount of DO in water. The EZO-DO sensor supports two data protocols I2C and UART (Universal Asynchronous Receiver Transmitter), which can be easily interfaced with Raspberry Pi model B. Its operating voltage and current are either 5 V/13.5 mA or 3.3 V/12.1 mA. Therefore, it is from these reasons that the EZO-DO was selected as a perfect sensor for the envisaged system.

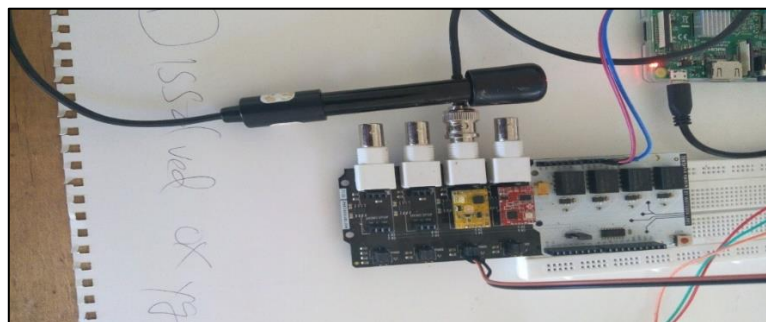

**Figure 17:** Dissolved Oxygen Sensor Module

#### (iv) Grove-Temperature Sensor V 1.2 Module

Grove Temperature V1.2 is an analogue sensor module, which use thermistors to measure the ambient temperature. It provides output measurements with an accuracy of +/- 1.5 °C and operates within the temperature range of -40 °C to +125 °C. Its operating voltage is 3.3 V-5 V, zero R of 100K and Nominal B constant of 4250 K-4299 K (Seeed, 2018). The Grove temperature v1.2 is easy to calibrate and it is supported by many platforms including Arduino, Raspberry Pi, Beagle bone, Wio and Linklone. It is from these reasons that the grove-temperature sensor v1.2 was selected as the perfect sensor for the proposed system.

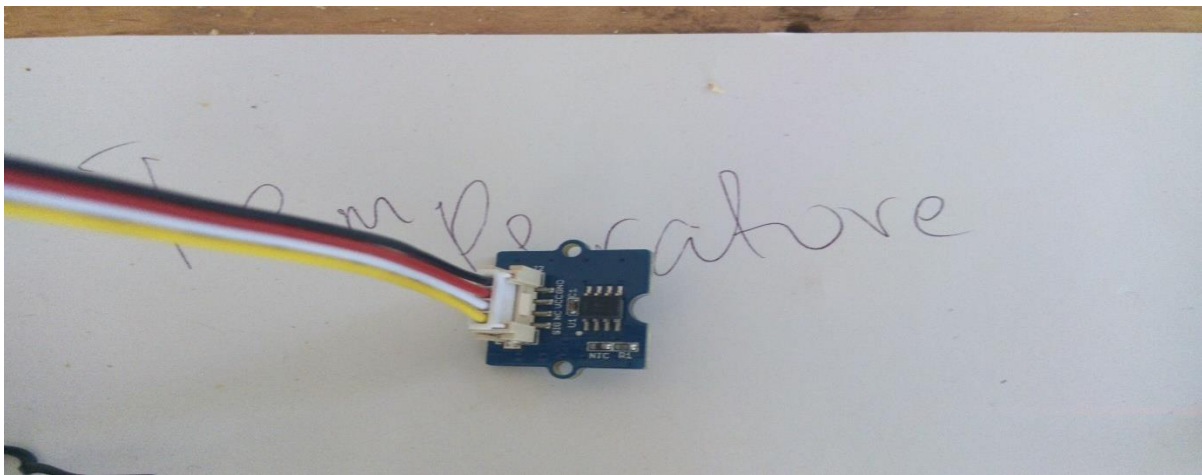
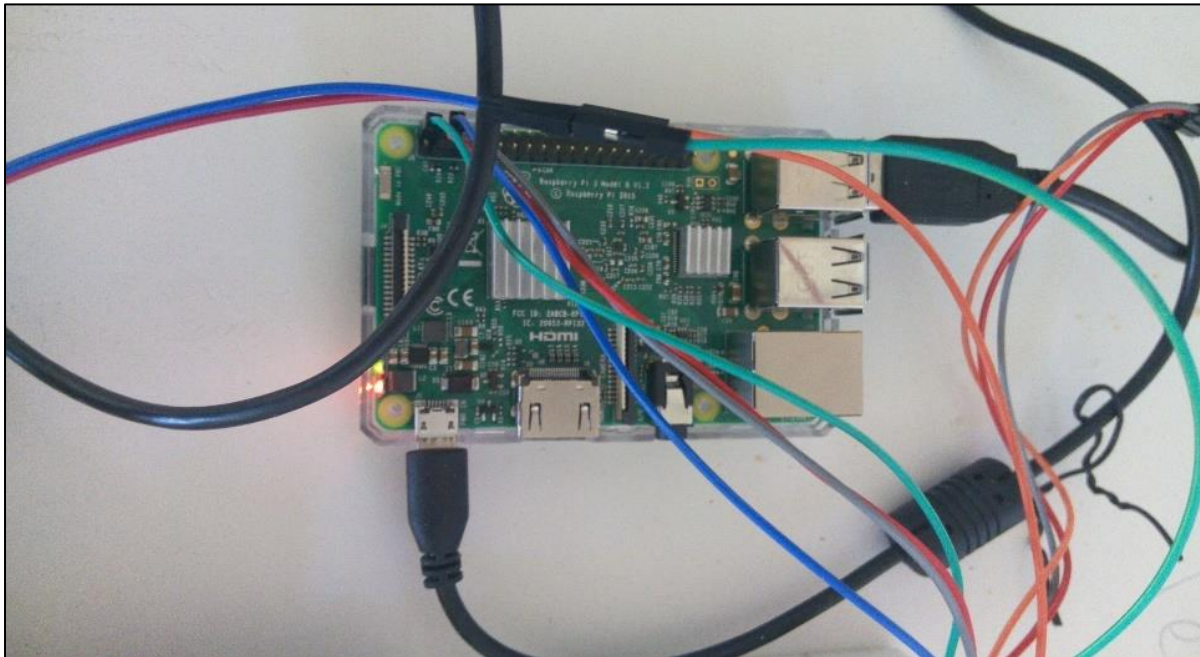

**Figure 18:** Temperature Sensor Module

#### (v) Single Board Computer

The Raspberry Pi 3 model B in Fig. 19 was selected among other single board computers to be used for development of DAU by considering many important features it possesses. Some of its features that are important for proper development of ISWQMSRS include use of python as a core programming language hence bringing simplicity, scalability, portability and richness of libraries (Li & Li, 2010). The Raspberry Pi 3 model B has a processing speed of 1.4 GHz, memory (RAM) 1 GB, supports external storage up to 32 GB (micro SD), low power consumption 5 V, 2 A and less expensive (\$ 35). Furthermore, it can be accessed remotely

using Secure Shell (SSH) and Virtual Network Computing (VNC) interfaces thus simplify its operation.



**Figure 19:** Raspberry Pi 3 Model B Single Board Computer

**(vi) Analog to Digital Converter Board (ADC)-ADS1115**

ADS1115 is a chip used to convert analog signals to digital signals. It has high precision since it provides 16-bit with 800 samples/second over I2C data protocol (Dicola, 2018). The ADS1115 chip has 4 input channels, which make it easy to accommodate 4 analog sensors in one chip. In addition, it uses a programmable amplifier with up to 16x, which makes it easier to amplify signals with smaller values. The chip operates with the voltage range from 2 V-5 V and current of 150  $\mu$ A. Also, it is easy to configure and interface with controllers. Among other analog to digital converters, the ADS1115 as shown in Fig. 20 is selected to be suitable to the proposed system.

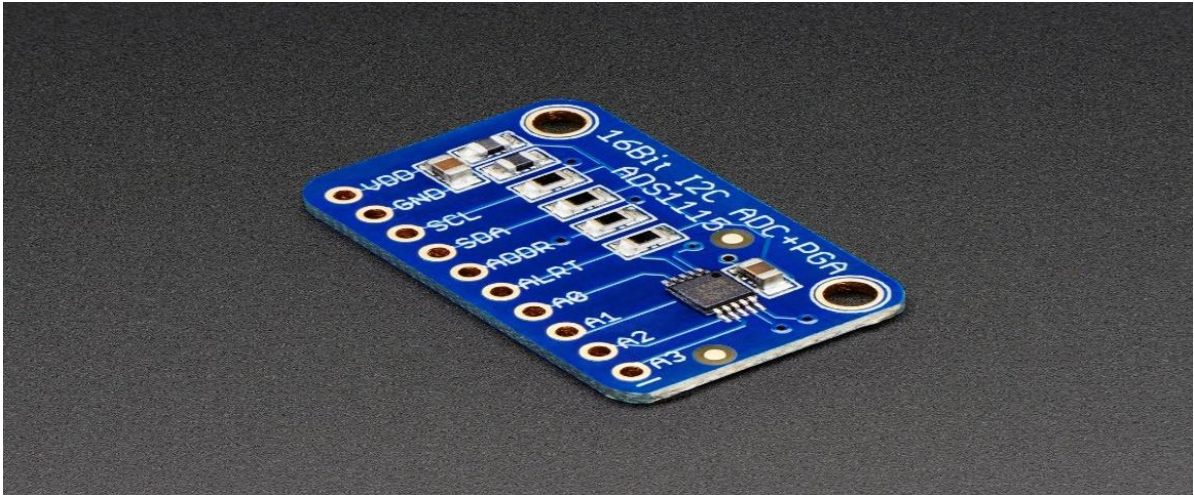

**Figure 20:** ADS1115 Module

#### **4.4.2 Connections of Sensing Components for Data Acquisition Unit**

SKU: SEN0169 pH sensor module in Fig. 21 is made up of 5-pins (V+, G, G, P and Po). V+ and G was connected to GPIO 5 V pin and Ground (GND) of Raspberry Pi 3 model B respectively. The Po pin was connected to A1 pin of the ADS1115. The ADS1115 is supplied with a 5 V pin of Raspberry Pi 3 model B and the same applied to GND pin. The I2C protocol pins SCL and SDA of ADS1115 were connected to SCL (GPIO2) and SDA (GPIO3) pin of Raspberry Pi 3 model B. The SKU: SEN0189 turbidity sensor module consisting of 4 pins (G, A, D, V). The V-pin was connected to 5V supply voltage and G-pin was connected to GND pin. A-pin was connected to A2 of ADS1115.

The EZO-DO sensor module consists of 6 pins (GND, TX/SDA, RX/SCL, Vcc, PRB and PGND). The Vcc pin was connected to voltage supply pin-5V and GND-pin was connected to GND-pin of Raspberry Pi 3 model B. TX/SDA-pin and also the RX/SCL-pin was connected to SDA-pin and SCL-pin of Raspberry Pi 3 model B board. The temperature sensor module consisted of 4 pin (SIG, NIC, VCC and GND). The SIG-pin was connected to Ao-pin of ADS1115, while VCC and GND pin was connected to the voltage supply source. The I2C interface was configured to allow communication between sensors and Raspberry Pi 3 model

B. It was configured under raspian operating system through command line interface, whereby the ADS1115 board was on address 0x48 and EZO-DO was on address 0x63.

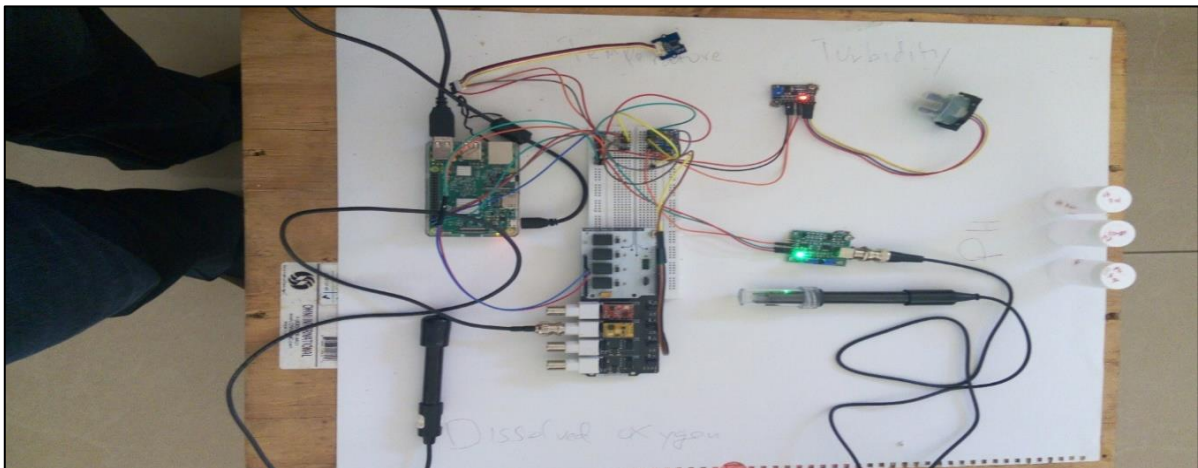

**Figure 21:** Connections of Sensing Components for Data Acquisition Unit

#### 4.4.3 Reading and Calibrating Data From Sensors

The data from sensors are retrieved from Raspberry Pi 3 model B - I2C pins using a program written in python3. The python3 was incorporated within raspian operating system. To read data from I2C pins and AdaFruit ADS1x15 python library was imported to a program in order to enable the process of reading of digital signals coming from ADS1115 channels. The digital signals from sensors were identified according to the assigned channel name of ADS1115 board. According to the design of this system the channel was assigned as follows: Ao-channel to temperature sensor, A1-channel to pH sensor, A2-channel to turbidity sensor. The measurements retrieved from the channels are expressed in a 16-bit format, which is within the range of -32768 to 32767. In decoding the results to analog value the equation  $VTB = (VADC \div 32767) \times 6.144V$  was used as recommended by ADS1115 board datasheet, whereby VTB refers to the analog voltage, VADC the digital voltage value and 6.144 V the reference voltage set when using a programmed gain of 2/3.

The calibration of sensors readings was done using both graphical methods and datasheet provided formulas. For that case, the temperature reading was determined by using mathematical relationship presented in equation (2), whereby thermistor constant (B), VPH is R of temperature sensor at 0° C and the voltage reading of analog to digital converter channel and the pH reading were obtained using graphical methods.

$$temperature\ reading = \frac{1.0}{\log\left(\frac{VTB}{B} + \frac{1}{298.15}\right)} - 273.15 \quad (2)$$

Multiple points were collected using six pH solutions with known values against sensor reading expressed in terms of voltage. The reading of the turbidity sensor was determined by applying the equation (4), which consists of the relationship between voltage and turbidity values. While the dissolved oxygen reading was obtained through the datasheet provided values.

$$pH\ reading = -14.3031\ VPH + 60.3142 \quad (3)$$

$$turbidity\ reading = -90.57VTB^2 + 123.1VTB + 1020 \quad (4)$$

#### 4.4.4 Data Transmission and Security Unit

##### (i) Wireless Module M028AT

In this system, the transfer of sensor measurements from data acquisition unit to a remote database server was facilitated using M028AT wireless module shown in Fig. 22. To achieve that, a network connection was established in two phases. In the first phase, the Raspberry Pi 3 model B single board computer was connected to M028AT through IEEE 802.11.g wireless standard. While, in the second phase, the M028AT wireless module was connected to the internet through a cellular network. To access the internet connection through the cellular network, the M028AT uses built-in SIM card module with a capacity to access multiple cellular network technologies such as Frequency Division Duplex (FDD)/LTE-1800/2100 MHz, Wideband Code Division Multiple Access (WCDMA) 1800 MHz/2100 MHz and GSM 900MHz /1800MHz. The M028AT is very useful when used in remote places since it uses a low-power rechargeable battery and it has high transmission range (Smile, 2018)

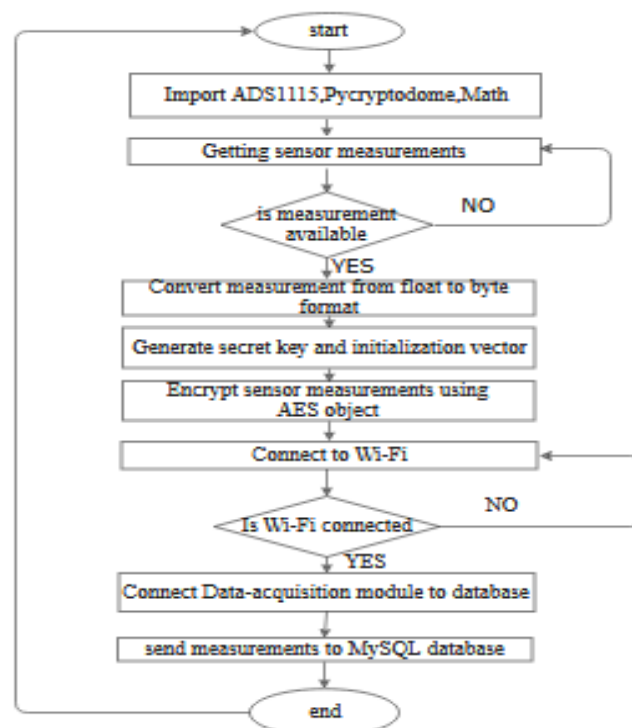

**Figure 22:** M028AT Wireless Module



## (ii) Implementation of AES in The Proposed System

In this system, the AES module was written in the Raspberry Pi 3 model B using python programming language. To achieve this, the pycryptodome package was installed in the single board computer. The pycryptodome package contains AES encryption algorithms libraries, which are used to facilitate the process of encrypting sensor measurements data. Thereafter, the implementation of the encryption module was as follows: generating of 16-bytes secret key and 16-bytes initialization vector, creating an AES cipher which is used to encrypt the data, converting the sensor measurements from float to a string data type, passing the sensor measurements to AES cipher algorithms to produce ciphertext, creating another ciphertext by concatenating ciphertext and initialization vector and sending ciphertext to a remote database. Figure 23 shows the flow diagram for AES encryption process.



**Figure 23:** Flowchart Diagram for Sensor Measurements and AES Encryption

To convert the measurements to plaintext the AES decryption module was created inside the web application. Again, the pycryptodome package is installed to facilitate the process of decryption. After installing pycryptodome package, the procedures to implement the decryption module were: generating the secret key and initialization vector which resemble to that of encryption module, creating AES decryption algorithms, passing the ciphertext to AES decryption algorithms, getting the plaintext and display the results in a web application.

#### 4.4.5 Database Implementation

The ISWQMSRS database was used to store both users' and application information. To achieve that, the design process started by analyzing the requirements which resulted in the formulation of four classes, attributes and methods used for data processing. The classes of this system are sensor, site, employee and site description. In this system, mysql database management system was selected because of the following factors: it is free and run in many platforms including windows, linux, mac os, it has large technical support and easily operated. The connection between django framework and mysql was done through settings.py file whereby database credentials including host, port, user and name were clearly defined and set. The django model.py file was used to create sensor, site, employee and site description classes that were mapped to the database tables. The fields of each class are mapped as table columns.

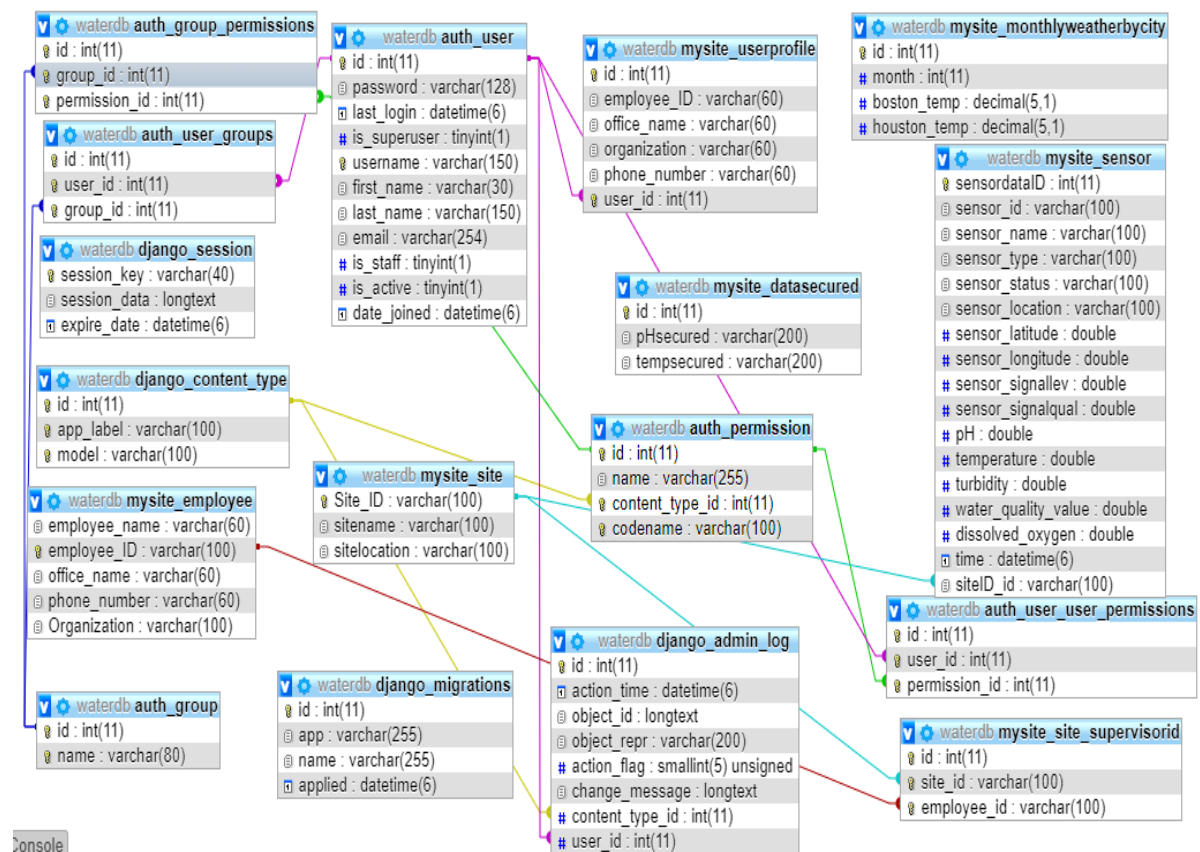

Figure 24: Relation Schema

#### 4.4.6 Decision Support Module Implementation

In its design, the module was developed purposely to provide the decision on the quality of water in Pangani river basin. It summarizes the water quality parameter data from the database,

which receives real-time measurements (pH, TURB, DO and TEMP) from remote sensors and compares them with pre-defined standards values defined by Tanzania Water Standards (Tanzania Bureau Standards, 2009). Thereafter, the SMS alerts would be sent to a water site supervisor for the immediate actions once measurements exceed the standard values, which are pH 6.5-8.5, DO 3-15 mg/l, TEMP 20-35 °C and TURB < 300 NTU (Tanzania Bureau of Standards, 2009)

The SMS module was developed inside a web application using nexmo-application interface . The nexmo-application interface is a set of cloud-based communications services that are designed to reduce the complexity caused by mobile carriers. The choice of SMS cloud-based application interfaces was based in the following: availability of its services on given location (country) based on mobile phone policies, cost of SMS services and support provided by the product's developers. Due to these factors, nexmo-application interface was deemed most suitable for the system among other SMS application itefaces such as textmagic and twilio (Clark-Dickson, Pamela, Neha & Angel, 2016).

In the ISWQMSRS, nexmo-application interface was installed and imported to the django framework through a class named nexmo. A client method from the nexmo class was then set with a secret token and key as input parameters. Thereafter, the alert message was set to be sent to a responsible site supervisor once the parameters exceed the pre-defined standards.

The implementation process of decision support module was: querying pH, TEMP, DO and TURB measurements from database present on the previous three hours using query slicing techniques present in python list, evaluating the average values of each parameters provided by the previous process, comparing the average values of each parameter to pre-defined standard value, conditionally send the SMS alert to responsible site supervisors once the value of water quality parameter exceed the standard values and display the results for visualization.

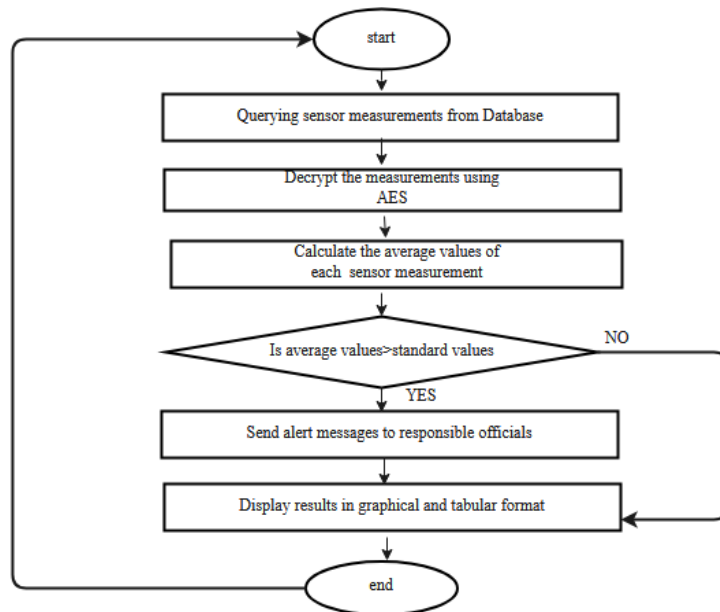

**Figure 25:** Flow Chart Diagram for Decision Support Module

#### 4.4.7 Web Application Implementation

The web application named Water Quality Monitoring System (WQMS) was developed to ensure it provides data storage, data visualization, data security, user registration and authentication, report, decision support and system administration. As presented in the block diagram in Fig. 14, the web application is located in the upper layer of the system architecture in order to facilitate the interactions of users with the system. Through this system, the basin information system administrator can not only be able to register, delete and edit user accounts but also create groups for systems users. In addition, the basin officials can login and view the real-time water quality information collected from sensor nodes located in the remote water sources both in tabular and graphical formats. Moreover, the WQMS is able to generate reports on the status of water quality and send SMS alerts to site supervisors once the quality of water is not up to standard values.

Consistent with this perspective, the next subsections provide description on the interfaces developed in this system.

##### (i) User Authentication

Figure 26 shows the user authentication interface whereby only registered users (basin officials) will be allowed to enter in the system by filling correct username and password fields. Using this interface, basin officials will be provided with a default password and username to login in the system for the first time, thereafter they will be allowed to change their username

and password credentials anytime they want. This system ensures security of the user's password by using Password-Based Key Derivation Function (PBKDF) algorithm and Secure Hash Algorithm (SHA256).

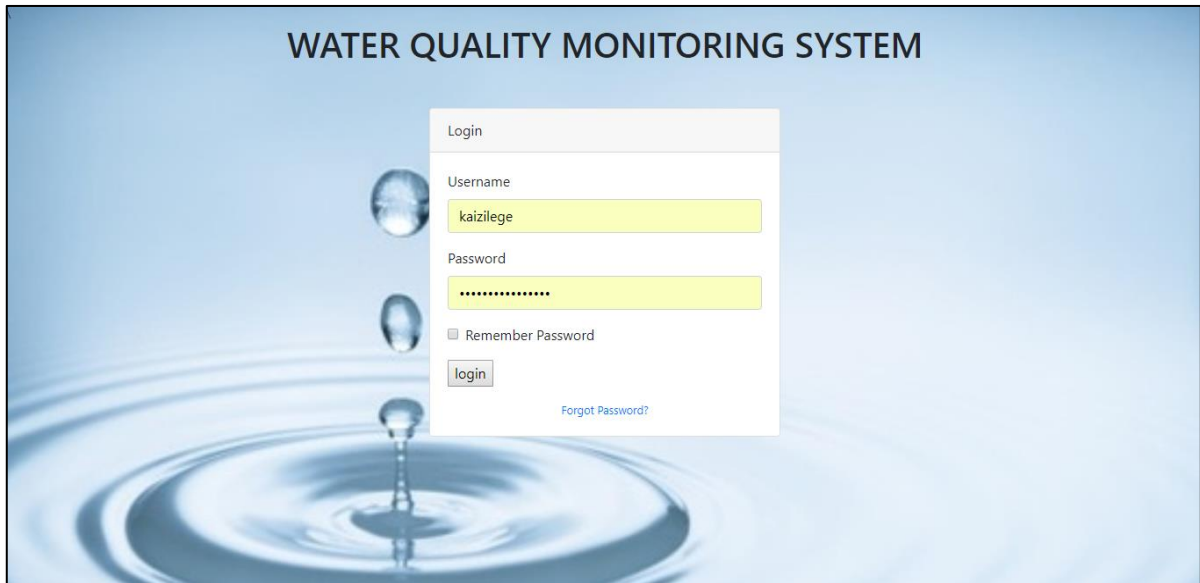

**Figure 26:** User Authentication Interface

### (ii) System Administration

For administration purpose, the WQMS system provides an interface as shown in the Fig. 27, which allow system administrator to create, delete and edit user accounts. Also the system administrator is responsible for creating default username and password for basin officials. Apart from that, the system administrator shall be responsible for creating managing database information for proper operation.

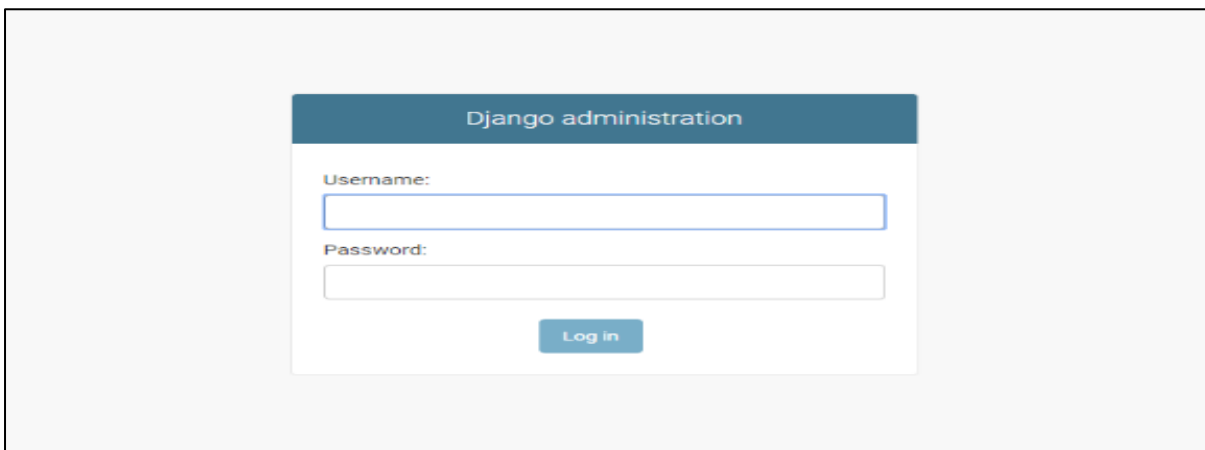

**Figure 27:** System Administration Interface

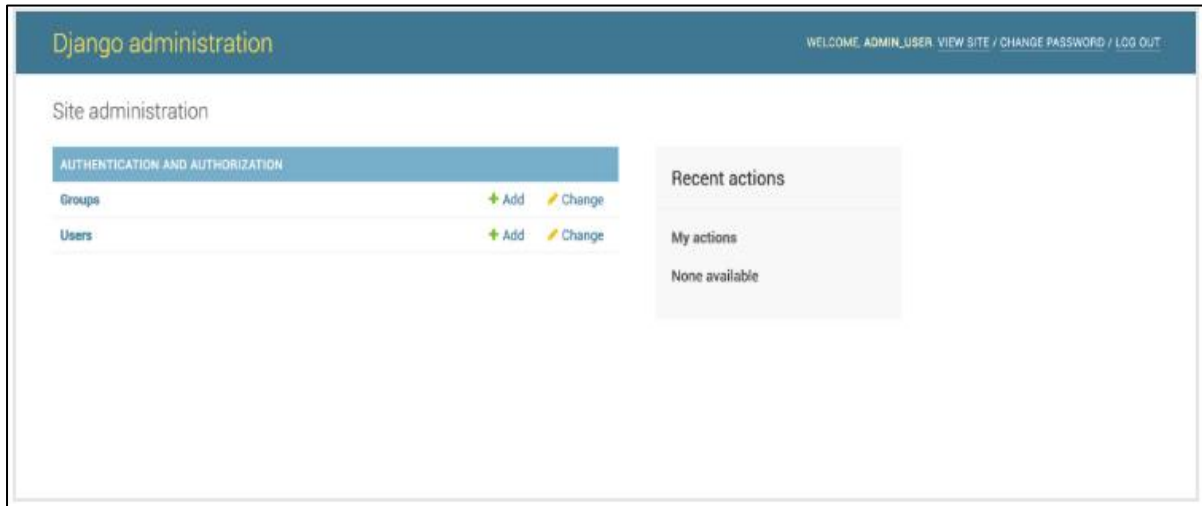

**Figure 28:** Administration Interface

### **(iii) Encrypted Sensor Measurements as Stored in Database**

Figure 29 shows a web page interface of encrypted sensor measurements including pH, TURB, DO and TEMP received from five sample sites. Using AES, these sensor measurements were encrypted in DAU level before transmitted over Wi-Fi and WCDMA to a central database system. To ensure security, these measurements were passed over 10-rounds of transformations before it produced a ciphertext. Applying AES encryption standards to the developed prototype ensured prevention of a sensor network attacks such as interruption attacks, interception attacks, fabrication and modification attacks. Both of these attacks may result in false errors message, denial network traffic and control of information if security measures are not in place.

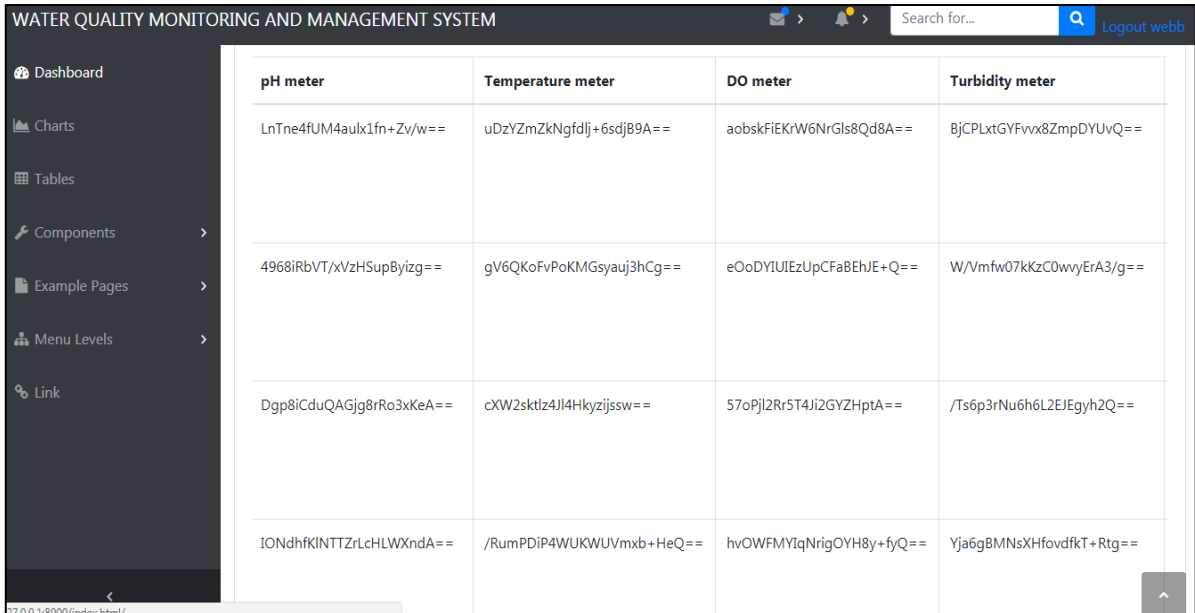

**Figure 29:** Encrypted Sensor Measurements Interface

**(iv) Displaying Sensor Measurements in Tabular View**

Figure 30 presents, a web interface displaying water quality information collected from remote sensors in tabular format. Firstly, the information collected from sensor nodes are queried from database and passed in AES decryption algorithms before displayed on the interface. The aim of having security procedures when displaying this information is to ensure data integrity is maintained. The information displayed include site name, location, time and date, pH, temperature, turbidity and dissolved oxygen ensure provision of a clear description on the status of water quality in a given area.

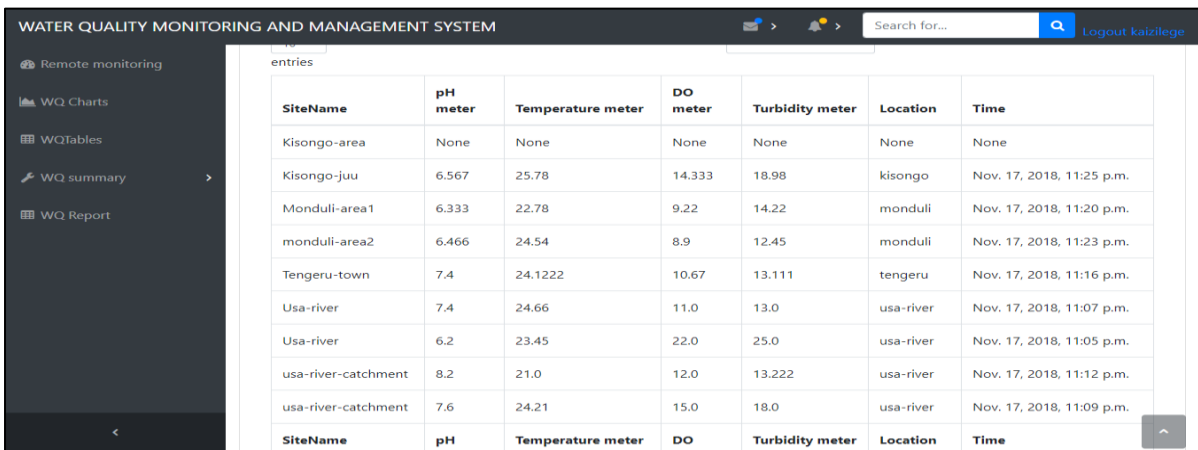

**Figure 30:** Sensor Measurements Displayed in Tabular Format

### (v) Displaying sensor measurements in Graphical View

In Fig. 31, the real-time water quality information is displayed in graphical format. These graphs were achieved through the use of chartit python library, highcharts, jQuery and JavaScript. Mainly, the use of graph in this system is to show trends of water quality information presented in time series whereby datapoints in Y-plane are pH, turbidity, temperature and dissolved oxygen while the datapoint at X-plane is time.

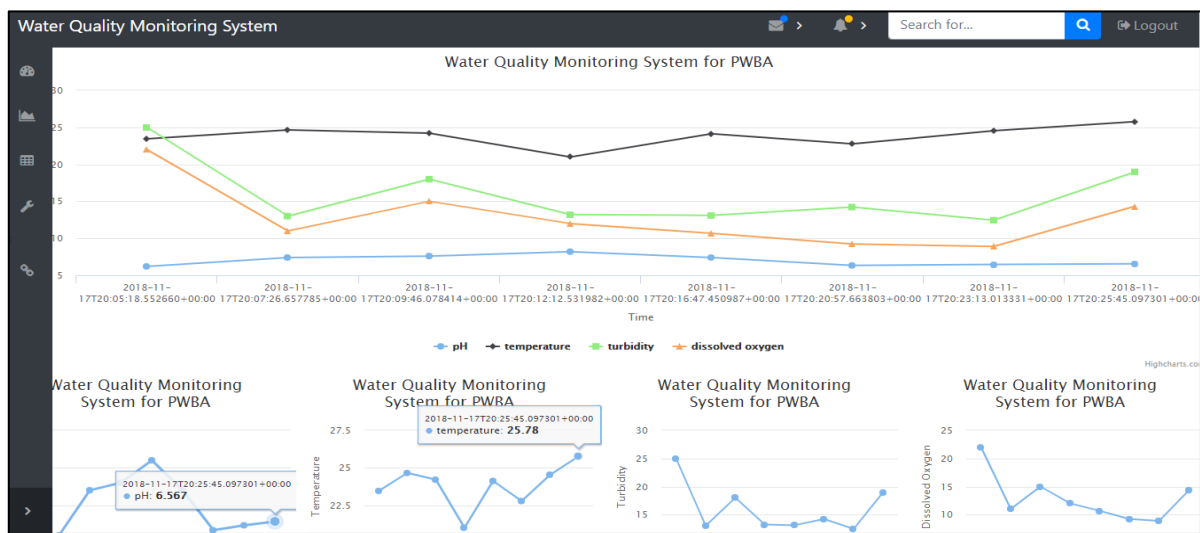

**Figure 31:** Real-Time Water Quality Information Displayed in Graphical Format

### (vi) Generating Water Quality Reports

The Water Quality Monitoring System (WQMS) consisted of a designated module for generating reports on the status of water quality information in the basin. Using this module basin officials can generate and print reports. As described earlier in functional requirements, the reports are needed by basin officials for decision making and for planning of different activities concerning water quality monitoring. Apart from that, the reports can be used as an alternative way of storing information in the printed format. In this system, the implementation of report generation module was achieved through the use of xhtml2pdf.pisa and BytesIO python libraries. Figure 32 present, sample pdf file reports generated by WQMS system.



Sales Report 1 / 1

Water Quality Report - 18/11/2018

Name:

Sitename	pH	Temperature	Dissolved_Oxygen	Turbidity	Location	Time
Kisongo-juu	6.567	25.78	14.333	18.98	kisongo	Nov. 17, 2018, 11:25 p.m.
monduli-area2	6.466	24.54	8.9	12.45	monduli	Nov. 17, 2018, 11:23 p.m.
Monduli-area1	6.333	22.78	9.22	14.22	monduli	Nov. 17, 2018, 11:20 p.m.
Tengeru-lown	7.4	24.1222	10.67	13.111	tengeru	Nov. 17, 2018, 11:16 p.m.
usa-river-catchment	8.2	21.0	12.0	13.222	usa-river	Nov. 17, 2018, 11:12 p.m.
usa-river-catchment	7.6	24.21	15.0	18.0	usa-river	Nov. 17, 2018, 11:09 p.m.
Usa-river	7.4	24.66	11.0	13.0	usa-river	Nov. 17, 2018, 11:07 p.m.
Usa-river	6.2	23.45	22.0	25.0	usa-river	Nov. 17, 2018, 11:05 p.m.
Kisongo-area	None	None	None	None	None	None

**Figure 32:** Water Quality Report in PDF Format

**(vii) Notification Alert**

Figure 33 present, the sample SMS sent to a site supervisor after the pH of 9 was measured at Nambala site in upper Pangani river basin. This pH value exceeded the standard value range (6.5-8.5), hence the notification message was triggered for intervention. Consequently, through the decision support module developed in this system the average values of water quality parameters (pH, TEMP, TURB and DO) are evaluated after every hour and if the average values of water quality parameters exceed either of these ranges: pH > 8.5 and pH < 6.5, DO > 3 and DO < 6, TEMP > 20 and TEMP < 35 and TURB < 300 NTU, then the notification message is automatically sent to the responsible site supervisor.

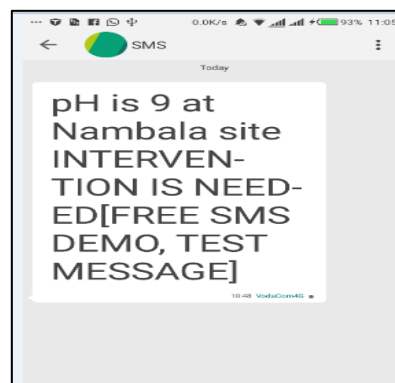

**Figure 33:** SMS Sent to Specific Officials After pH Value Exceed Standard Limit

## **4.5 System Testing and Validation**

After ISWQMSRS design and implementation completed, each unit that was used in the development of the same was tested to evaluate the way it performed and its compliance with the system requirements. Both the white box and black box methodologies were adopted during testing and validation of this system. In the white box methodology whereby, the internal working of the system is tested, the matlab simulink was used for simulating pH and TEMP sensor characteristics. On the other hand, unit testing and integration testing was applied in the authentication unit, graphical and tabular display unit, decision support unit, SMS unit, Data Acquisition unit, report generation unit and AES encryption and decryption unit. The results obtained after testing the systems units are presented and discussed proceeding sections.

### **4.5.1 Simulation of Sensor Circuits**

Circuit simulation for sensor nodes was conducted to gain insight on how sensors operate when subjected to different conditions. The reason of using circuit simulation in this study was to avoid permanent damage to the devices if testing was done directly. Therefore, the simulation testing was performed using simulink-matlab software tool as described in the next subsections.

#### **(i) pH Sensor Simulation Circuit**

The SKU:0161 pH sensor circuit as shown in the Fig. 33 was simulated using matlab-simulink environment. The pH sensor circuit consists of analog input source with the range of -430 mV to 430 mV. According to manufacturer datasheet the SKU:0161 sensor range of pH value (0-7) is within the range of input voltage range of -430 mV to 430 mV. The voltage follower (Op-Amp) circuit was used as an isolator between input and output circuit, while the potential divider circuit (R1/R2) was used to provide reference voltage between electrodes. The simulation results are as shown in the Fig. 34 and Fig. 35. The results show that, there is a liner relationship between pH as output voltage and input voltage, indicating coherence with the Nernst Equation.

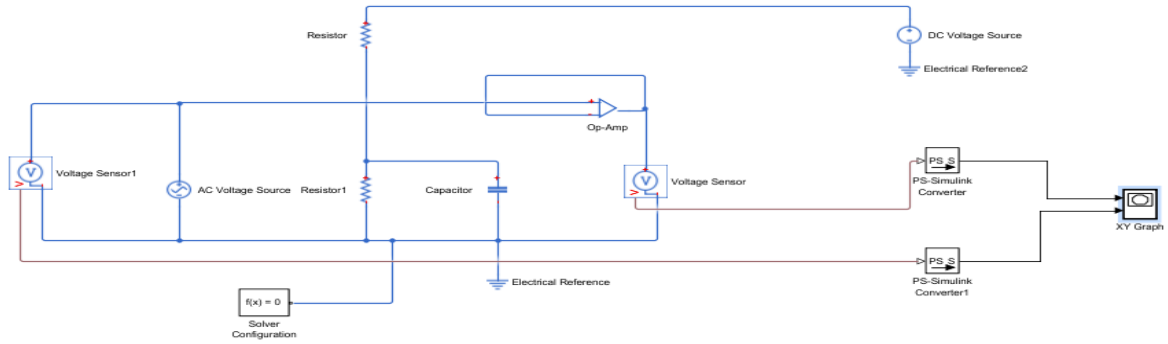

**Figure 34:** pH Simulation Sensor Circuit

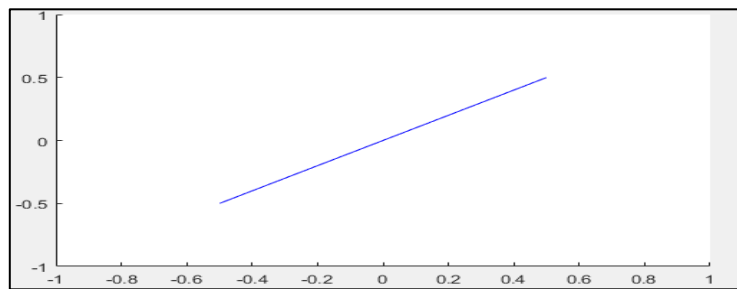

**Figure 35:** Liner Relationship Between pH as Output Voltage and Input Voltage

**(ii) Temperature Sensor Simulation Circuit**

The glove-temperature sensor v 1.2 circuit was simulated using matlab-simulink environment as presented in Fig.36. The temperature sensor circuit consist of 5 V DC input source. A Negative Temperature Coefficient (NTC) thermistor (R4) with nominal value of 100 K was used as a temperature sensor, while the potential divider circuit  $R1 = R2 = R3 = 100\text{ K}$  was used to provide reference voltage between electrodes. The simulation results in Fig. 37 indicate an exponential relationship between thermistor and temperature as recommended by stein-chart equation and sensor manufacture data sheet.

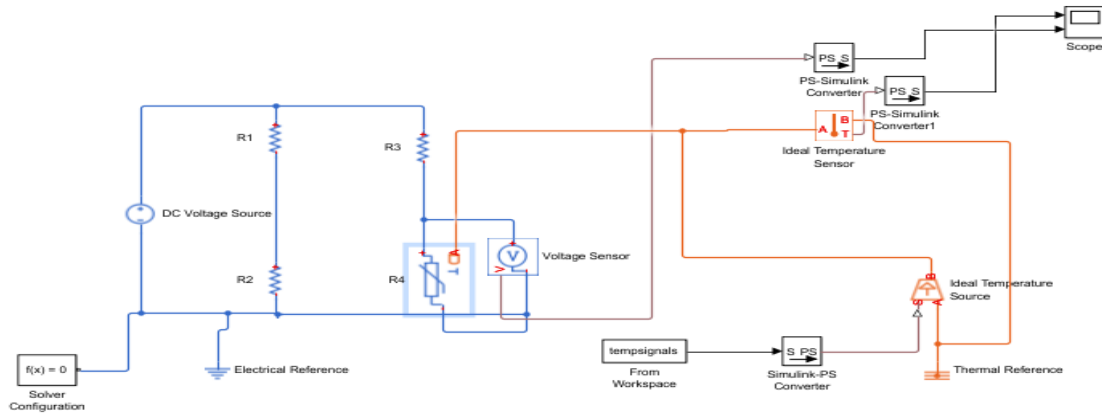

**Figure 36:** Temperature Sensor Simulation Circuit

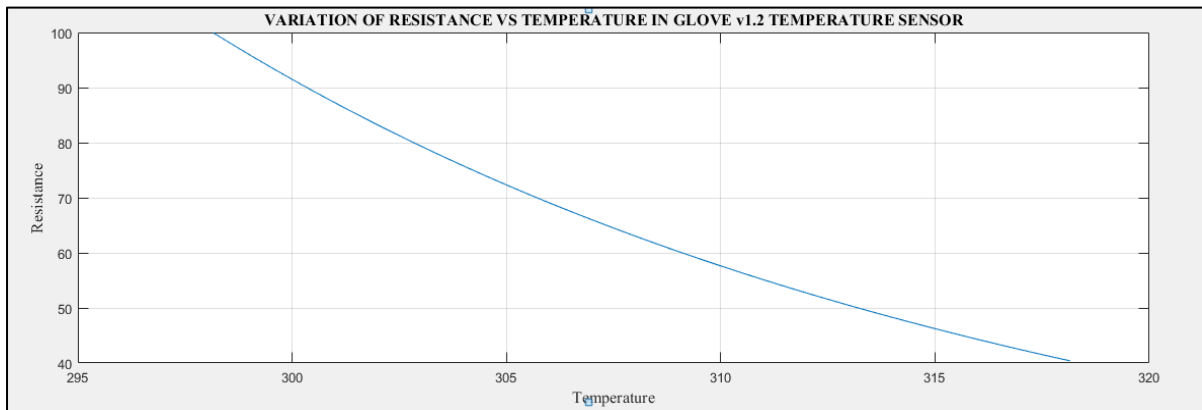

**Figure 37:** Exponential Relationship Between Thermistor and Temperature

#### 4.5.2 Web Application System Unit Testing

For the water quality monitoring web application to become truly responding to functional requirements, a number of unit tests was performed in the authentication unit, graphical and tabular display unit, decision support unit, SMS unit, Data Acquisition unit, report generation unit and encryption and decryption unit. The results obtained for individual test as described the following sub-sections.

##### (i) User Authentication Testing

The objective was to check if users can login and logout of the system. Table 8 shows that the system performed as expected.

**Table 9:** User Authentication Test

<b>Test</b>	<b>Input</b>	<b>Output</b>	<b>Results</b>
Login page	Enter username and password	Remote monitoring Page	Pass
Logout Page	Click logout button	Login Page	Pass

**(ii) Testing Tabular and Graphical View**

The objective was to check if users can view water quality results in the web page. Table 9 shows that the system performed as expected.

**Table 10:** Tabular and Graphical Test

<b>Test</b>	<b>Input</b>	<b>Output</b>	<b>Results</b>
Remote Monitoring Page	Click WQTables button	Water Quality Table Page	Pass
Remote Monitoring Page	Click WQCharts button	Water Quality Charts page	Pass

**(iii) System Administration Testing**

The objective was to test if system administrator can manage user accounts. Table 10 shows that the system performed as expected.

**Table 11:** System Administration Testing

<b>Test</b>	<b>Input</b>	<b>Output</b>	<b>Results</b>
Administration Page	Enter administrator username and password	Site Administration Page	Pass
Site Administration Page	Click User Button	User Form Page	Pass
Site Administration Page	Click User Group Button	User Group Page	Pass
Site Administration Page	Click User Profile Button	User Profile Page	Pass

**(iv) Testing SMS, AES encryption and Report Generation Unit**

The objective was to test if the system can send SMS, secure water quality data using AES encryption and decryption unit and generate reports. Table 11 shows that the system performed as expected.

**Table 11:** SMS, AES Encryption and Report Generation Unit Testing

<b>Test</b>	<b>Input</b>	<b>Output</b>	<b>Results</b>
SMS	Message and User contacts	Message and Sent and received	Pass
AES encryption	Water Quality Data	Encrypted data transmitted	Pass
AES decryption	Water Quality Data	Decrypted viewed information	Pass
Remote Monitoring Page	Click Report Generation Button	PDF report generated	Pass

**4.5.3 System Performance Test**

System performance test was conducted to assess the responsiveness of ISWQMSRS when subjected to different types of real time environment. Since, this system operate under Internet

IoT based framework, whereby sensor devices generate large amount of data from remote areas which are stored, analyzed and visualized by users of the system, then there was a need for achieving high system performance with regard to sensor accuracy and sensitivity, network connection, data transmission, network bandwidth and signal reception. The results obtained are discussed in the following sub-sections.

**(i) Sensor Performance Test**

In conducting sensor performance test the objective was to measure accuracy and response of sensor devices when measuring different samples of water solution. For instance, during measurement of pH, three samples of known pH values measured by A221 pH meter was compared with measurements obtained by SKU: SEN061 pH sensor, when measuring the same samples. The results obtained are as shown in Table 12.

**Table 12:** pH Sensor Performance Test

<b>Parameters</b>	<b>pH meter (A221)</b>	<b>pH sensor (SKU: SEN061)</b>	<b>Error = pHsensor-pHmeter</b>
Reading 1	7.01	7.087	0.077
Reading 2	4.00	4.001	0.001
Reading 3	10.00	10.062	0.062

The results show that the SKU: SEN 061 pH sensor was able to measure samples solutions of known pH values with minimum average error of about 0.046 indicating that it was suitable for the intended operation. Apart from that, test results show the SKU: SEN 061 sensor response time was less than 2 minutes implying that the system can provide the needed data in real time environment.

Furthermore, the SKU: SEN0189 turbidity sensor was tested using samples of known turbidity values measured by H2100Q turbidity meter. The results obtained are as shown in the Table 13.

**Table 13:** Turbidity Sensor Performance Test

<b>Parameters</b>	<b>Turbidity meter(H2100Q)</b>	<b>Turbidity sensor SKU: SEN0189</b>	<b>Error=Turbidity_sensor-Turbidity_meter</b>
Reading 1	17.5NTU	16.93NTU	0.57
Reading 2	7.71 NTU	8.43 NTU	0.72
Reading 3	5.42 NTU	6.08 NTU	0.66

Overall test results show that the performance of turbidity sensor was good despite having some incorrect reading to some few samples. In addition, test results show an average response time for the turbidity sensor SKU: SEN089 was 3 minutes, implying that the turbidity data can be obtained in short time.

With regard to dissolved oxygen sensor and temperature sensor tests, both EZO-DO and Glove V1.2 demonstrated high degree of accuracy after series of tests as presented in Table 14 and Table 15. In the case of Glove V1.2, measurements were taken at same time as thermometer readings and compared. While in the case of EZO-DO, measurements were compared to readings of a known dissolved oxygen values of a solutions.

**Table 14:** Dissolved Oxygen Performance Test

<b>Parameters</b>	<b>Dissolved Oxygen (DO)meter (EXDO210)</b>	<b>Dissolved Oxygen sensor (DO): EZO-DO</b>	<b>Error=Dissolved Oxygen Sensor-Dissolved Oxygen meter</b>
Reading 1	6.08	6.14	0.06
Reading 2	5.97	6.59	0.38
Reading 3	6.60	6.94	0.34



**Table 15:** Temperature Sensor Performance Test

<b>Parameters</b>	<b>Thermometer</b>	<b>TEMPerature sensor: Glove TEMPerature sensor V1.2</b>	<b>Error=TEMPerature Sensor-Thermometer</b>
Reading 1	24	23.42	0.58
Reading 2	26	24.77	1.23
Reading 3	28	29.35	1.35

**(ii) Single Board Computer Performance Test**

In conducting single board computer, the the Raspberry PI 3 model B single board computer was used. The Raspberry PI 3 model B was responsible for reading and transmitting data collected from sensors to a remote server unit, establishing network connection between sensor nodes and server and ensuring secure transmission of data. Hence, the performance test was designed such that each single board computer function described above are correctly measured. Table 16 presents the test results of the single board computer functions.

**Table 16:** Single Board Computer Performance Test

<b>Test</b>	<b>Output</b>
Reading sensor data	Single Board Computer reads sensor data after every five (5) minutes. Although it read data after every second. The five (5) minutes was set to ensure correct sensor measurements are taken from sensors
Establish network connection	Single Board Computer successfully connect to a Wi-fi network. Depending on the access point transmission power, the Single Board Computer access network up to 200 m
Secure transmission of data	Single Board Computer successfully provide AES encryption service to transmitted data

### **(iii) Evaluation of Water Quality in Pangani River Basin as per collected data**

These measurements are obtained from Nambala, Tengeru catchment, Tengeru Juu, Usa catchment and Usa town. The pH values recorded are 6.4 , 6.7, 8.4 and 6.8, DO values recorded 6.0, 8.2, 14.0, 11.2 and 15.0, TURB the recorded measurements are 7.5, 41.0, 23, 24.0 and 27.0, while water TEMP recorded are 23.0, 23.6, 22.45, 21.0 and 24.45. Both of these measurements are within the standard value of safe water uses except for Tengeru catchment whereby there was an act of feeding livestock during the collection of samples. Furthermore, the results are obtained within a short time duration as opposed to the existing manual systems which take about 6 hours to complete measurements of five sites.

## CHAPTER FIVE

### CONCLUSION AND RECOMMENDATIONS

#### 5.1 Conclusion

The concerns about preserving water quality in river basins due to increase in water pollution and waterborne diseases worldwide has been an agenda in years. In developing countries like Tanzania where there is substantial decline of water quality in rivers caused by toxic chemicals, domestic wastes and unnecessary nutrients have necessitated the government through WBA to establish networks of stations for monitoring meteorological, quality and quantity aspects of the water in the river basins. However, the main challenges faced by water basin authorities is lack of modern and sophisticated equipment to measure physical, chemical and biological water parameters timely, accurately and reliably. The findings obtained from qualitative study conducted to Pangani river basin staffs indicate that at present water monitoring systems are inefficient since it takes a long time to obtain measurements results and also it is costly in terms of man power and finances required to facilitate the monitoring process. In addition, the results have revealed that the storage and security of data collected from different stations are insecure because the collected data is stored manually in books and files. Hence, this study aimed at designing an improved water quality monitoring and management system that could respond to impending challenges observed in water quality measurement based on existing literature, communication and sensor technology. Specifically, the study capitalised on use of wireless sensor technology to enhance the flow of information from the remote water stations to central office management system.

The developed system consists of three layers, lower layer, middle layer and upper layer. The lower layer consisted of four sensor devices which are pH sensor, turbidity sensor, temperature sensor and dissolved oxygen sensor. It also consisted of single board computer unit and analog to digital converter for digital signal processing. The middle layer consisted of wireless network module, which was responsible for connecting sensor nodes with internet to allow transfer of data from single board computer unit to a remote database. The upper layer was made up of application software for visualizing real-time water quality data, generating water quality status reports, providing alerts in the case of poor water quality in the basin and ensuring storage and security of data at low cost.

Unlike the existing water quality measuring systems, the ISWQMSRS ensured secure transmission and storage of sensor measurements using AES algorithms. In addition, the system was able to be accessed remotely for status check and re-programming using SSH and VNC network interfaces. Moreover, ISWQMSRS was also able to use a web application to provide real-time visualization of the sensor measurements in tabular and graphical formats. It also proved to facilitate decision support by sending SMS alerts to specific officials once measured values were above predefined standard values. Furthermore, the developed system was able to generate reports on the status of water quality present in the basin using report generation module.

Based on the results, it was evident that current advances in communications blended with sensor technology, could improve the quality of water monitoring systems in river basins in Tanzania, provided that the authorities are open to embrace the available technology in their development plans.

## **5.2 Recommendations**

From the views expressed by the Pangani river basin staffs and the resultant outcome of the ISWQMSRS were developed to address the existing challenges of water quality management, this study recommends the following:

- (i) The use of secure water quality monitoring and managements system like ISWQMSRS could be adopted by WBA to ensure reliable collection and monitoring of water quality data in the river basin in Tanzania.
- (ii) The existing water quality monitoring practices in the river basin have proven to be inefficient and costly. Therefore, the Tanzania government should allocate the portion of its budget to deploy ICT related system to manage its natural resource since, it has proved to be effective in decision support, planning and future prediction but also less costly.
- (iii) This has entrenched only on physical water quality parameters determination and monitoring. Therefore, more research work on efficient ways of monitoring chemical and biological parameters of water quality in basins is of utmost importance, because they still pose a big danger on human health.

## REFERENCES

- Abdelmalik, K. W. (2016). Role of statistical remote sensing for Inland water quality parameters prediction. *Egyptian Journal of Remote Sensing and Space Science*. <https://doi.org/10.1016/j.ejrs.2016.12.002>
- Abu-aisheh, A. (2014). The Application of Psim & Matlab / Simulink In Power Electronics Courses, 7(10), 3–7. <https://doi.org/10.3991/ijoe.v7i3.1647>
- Adikari, S., Mcdonald, C., & Campbell, J. (2009). Little Design Up-Front : A Design Science Approach to Integrating Usability into Agile Requirements Little Design Up-Front : A Design Science Approach to Integrating Usability into Agile Requirements, (July). <https://doi.org/10.1007/978-3-642-02574-7>
- Ahmad, A. M. (2015). *Effects Of Wastewater Discharge On Fresh Water Quality*. Dar es Salaam: Open University Tanzania. Retrieved from <http://ccs.infospace.com/>
- Aleksić, O. S., & Nikolić, P. M. (2017). Recent Advances In Ntc Thick Film Thermistor Properties And Applications, 30(September), 267–284. <https://doi.org/10.2298/Fuee1703267a>
- Alsaleh, S., & Haron, H. (2016). The Most Important Functional and Non-Functional Requirements of Knowledge Sharing System at Public Academic Institutions : A Case Study, 4(2). <https://doi.org/10.7763/LNSE.2016.V4.242>
- Amballi, A. R., & Mahanta, V. (2018). Django The Python Framework. *International Journal of Computer Science and Research*, 6(2), 59–63. <https://www.researchpublish.com>.
- Ammam, M. (2018). Applications of Nernst Equation. Chemistry LibreText (January). Retrieved from <https://www.chem.libretexts.org>.
- Atlas. (2018). EZO-Dissolved Oxygen. Retrieved September 15, 2018, from [https:// www.atlas-scientific.com/\\_files/\\_datasheets/\\_circuit/do\\_EZO\\_datasheet.pdf](https://www.atlas-scientific.com/_files/_datasheets/_circuit/do_EZO_datasheet.pdf)
- Azeez, T. (2017). Impact of Global System for Mobile Communications (GSM) on Employment and Earnings in Ilorin, Nigeria, (August).
- Barcelo-Ordinas, J. M., Chanet, J. P., Hou, K., M., & Garcia-Vidal, J. (2016). A survey of wireless sensor technologies applied to precision agriculture. *Precision Agriculture*, 13

(7), 801–808. <https://doi.org/10.3920/978-90-8686-778-3>

- Beynon, M., Rasmeyan, S., & Russ, S. (2002). A new paradigm for computer-based decision support. *Decision Support Systems*, 33(2), 127–142. [https://doi.org/10.1016/S0167-9236\(01\)00140-3](https://doi.org/10.1016/S0167-9236(01)00140-3)
- BMI. (2016). Tanzania Telecommunications & Wireless Market Research Report. BMI Research Q3. Retrieved september 2017 from <http://www.awex-export.be/files/library/Fiches-pays/AFPMO/Tanzanie/Etudes/BMI-Tanzania Telecommunications.pdf>.
- Byeon, S., Choi, G., Maeng, S., & Gourbesville, P. (2015). Sustainable Water Distribution Strategy with Smart Water Grid, 4240–4259. <https://doi.org/10.3390/su7044240>
- Strategy with Smart Water Grid, 4240–4259. <https://doi.org/10.3390/su7044240>.
- Brown, J., Turpie, B., Clark, A., Duffel-Graham, G., Lugomela, H., Sadiki, B. L., & Benno, A. (2010). *Pangani River System: State of the Basin Report*. Retrieved November 3, 2018 from <https://www.portals.iucn.org/library/files/documents/2007-002.pdf>.
- Cadence. (2018). OrCAD Capture Fast, intuitive PCB schematic design solution. Retrieved November 4, 2018, from <https://www.orcad.com/products/orcad-capture/overview>
- Cavazza, F. (2018). The Role of ICT in Improving Sequential Decisions for Water Management in Agriculture. <https://doi.org/10.3390/w10091141>
- Chanzi, G. (2017). Heavy Metal Pollution Assessment along Msimbazi, 17(5), 1–8. <https://doi.org/10.9734/JSRR/2017/38526>
- Chapman, D. V., Bradley, C., Gettel, G. M., Hatvani, I. G., Hein, T., Kovács, J., Várbíró, G. (2016). Developments in water quality monitoring and management in large river catchments using the Danube River as an example. *Environmental Science and Policy*, 64, 141–154. <https://doi.org/10.1016/j.envsci.2016.06.015>
- Chilundo, M., Kelderman, P., & Ókeeffe, J. H. (2008). Design of a water quality monitoring network for the Limpopo River Basin in Mozambique. *Physics and Chemistry of the Earth*, 33(8–13), 655–665. <https://doi.org/10.1016/j.pce.2008.06.055>
- Clark-Dickson, P., Pamela, N. D., Neha, A. D., & Angel. (2016). Application-to-Person Messaging Helping enterprises to respond to consumers ' changing.

- DFRobot. (2018). PH meter manual. Retrieved September 17, 2018, from <https://www.dfrobot.com/product-1110.html>
- Dicola, T. (2018). ADS1115. Retrieved August 31, 2018, from <https://learn.adafruit.com/raspberry-pi-analog-to-digital-converters/ads1015-slash-ads1115>
- Eberspacher, J. & Hans-JoÈ, V. (2001). *GSM Switching, Services and Protocols*. (J. Wiley, Ed.) (second). Germany.
- Faustine, A., Mvuma, A. N., Mongi, H. J., Gabriel, M. C., Tenge, A. J., Kucel, S. B., & Faustine, A. (2014). Wireless Sensor Networks for Water Quality Monitoring and Control within Lake Victoria Basin: Prototype Development Wireless Sensor Networks, Lake Victoria Basin, Gateway, Sensor Nodes. *Wireless Sensor Network*, 6(6), 281–281. <https://doi.org/10.4236/wsn.612027>
- Firesmith, D. G. (2014). Use Cases: the Pros and Cons. Retrieved December 17, 2018, from <https://www.cs.hmc.edu/~mike/courses/mike121/readings/reqsModeling/firesmith.htm>
- Fondriest. (2016). Dissolved Oxygen Measurement Methods. Retrieved November 16, 2018, from <https://www.fondriest.com/environmental-measurements/equipment/measuring-water-quality/dissolved-oxygen-sensors-and-methods/>
- Geerts, G. L. (2011). International Journal of Accounting Information Systems A design science research methodology and its application to accounting information systems research. *International Journal of Accounting Information Systems*, 12(2), 142–151. <https://doi.org/10.1016/j.accinf.2011.02.004>
- Gholamzadeh, B., & Nabovati, H. (2008). Concepts for Designing Low Power Wireless Sensor Network. *World Academy of Science, Engineering and Technology*, 45, 2(9), 559–565.
- GLOWS-FIU. (2014). *Environmental Flow Recommendations for the Ruvu River Basin*. <https://doi.org/10.1017/CBO9781107415324.004>
- GoldSim. (2017). Using GoldSim and Dynamic Simulation to Support Integrated Water Resources Management. Retrieved from <https://www.goldsim.com/Downloads/WhitePapers/IntegratedWaterResourcesManagement.pdf>
- Gordon, B., Callan, P., & Vickers, C. (2008). WHO guidelines for drinking-water quality. *WHO Chronicle*, 38(3), 564. [https://doi.org/10.1016/S1462-0758\(00\)00006-6](https://doi.org/10.1016/S1462-0758(00)00006-6)

- Granfelt, S. A. (2017). *Process Flow Documentation A Flowchart Guide For Micro & Small Business*.
- Hellar-Kihampa, H., de Wael, K., Lugwisha, E., & van Grieken, R. (2013). Water quality assessment in the Pangani River basin, Tanzania: Natural and anthropogenic influences on the concentrations of nutrients and inorganic ions. *International Journal of River Basin Management*, *11*(1), 55–75. <https://doi.org/10.1080/15715124.2012.759119>
- Hu, X., Wang, J., Yu, Q., Liu, W., & Qin, J. (2008). Water Quality Monitoring System Using Zigbee Based Wireless Sensor Network. *International Journal of Engineering & Technology*, *9*, 24–28.
- Islam, M (2012). Overview of Wireless Sensor Network. <https://doi.org/http://m/dx.doi.org/10.5772/49376>
- ISO. (1999). THE ISO 7027, 10–11.
- Jimenez, J. M., & Taha, M. (2018). Wireless Technologies for IoT in Smart Cities, (April). <https://doi.org/10.5296/npa.v10i1.12798>
- Karastogianni, S., Girousi, S., & Sotiropoulos, S. (2017). *pH: Principles and Measurement. Encyclopedia of Food and Health* (1st ed.). Elsevier Ltd. <https://doi.org/10.1016/B978-0-12-384947-2.00538-9>
- Karen. (2015). PyCharm Free for Teaching, Learning, and Academic Research. Retrieved November 10, 2018, from <https://my.vanderbilt.edu/softwarestore/2015/06/pycharm-free-for-teaching-learning-and-academic-research/>
- Kulinkina, A. V., Plummer, J. D., Chui, K. K. H., Kosinski, K. C., Adomako-Adjei, T., Egorov, A. I., & Naumova, E. N. (2017). Physicochemical parameters affecting the perception of borehole water quality in Ghana. *International Journal of Hygiene and Environmental Health*, *220*(6), 990–997. <https://doi.org/10.1016/j.ijheh.2017.05.008>
- Leshan, J. (2017). *Case Study on the Use of Information and Communication Technology in the Management of Rural Groundwater in China*.
- Letskowski, J. (2014). Doing database design with MySQL. *Journal of Technology Research*. Retrieved November 6, 2018, <https://www.researchgate.net/publication>.



- Li, J., & Li, L. (2010). Comparative research on Python speed optimization strategies. *Proceedings - 2010 International Conference on Intelligent Computing and Integrated Systems, ICISS2010*, 57–59. <https://doi.org/10.1109/ICISS.2010.5655011>
- Loganathan, J. (2018). Wireless sensor network applications: A study, (January). <https://doi.org/10.12732/ijpam.v118i11.47>
- MathWorks.(2018). MATLAB/SIMULINK. Retrieved November 20, 2018, from <http://www.mathworks/products/simulink.html>
- Mato, R. R. A. M. (2015). Groundwater quality degradation due to salt water intrusion in Zanzibar Municipality, 9(9), 734–740. <https://doi.org/10.5897/AJEST2015.1931>
- Max, S., Weiss, E., & Hierz, G. R. (2007). Analysis of WiMedia-based UWB Mesh Networks. *Proceedings - Conference on Local Computer Networks, LCN*, 919–926. <https://doi.org/10.1109/LCN.2007.34>
- Mendez, G. R., Yunus, M. A., & Mukhopadhyay, S. C. (2011). A WiFi based Smart Wireless Sensor Network for an Agricultural Environment, (April 2015). <https://doi.org/10.1109/ICSensT.2011.6137009>
- Ministry of Water. (2015). *Water Sector Status Report*. Tanzania Water and Sanitation Network. Retrieved March, 2017, <http://www.tzdpd.or.tz>
- Ministry of Water and Irrigation. (2016). *United Republic of Tanzania Ministry of Water And Irrigation Water Sector Development Programme Water Sector Status Report 2016*
- Mohammed, S. (2014). A Review of Water Quality and Pollution Studies in Tanzania, (January 2003). <https://doi.org/10.1579/0044-7447-31.7.617>
- Mohammed, S. M. (2014). The Assessment of Water Quality and Pollution in Tanzania. *University of Dar es Salaam, Institute of Marine Science*. Retrieved September, 2018, <http://www.oceandoc.org>.
- Myre, E., & Shaw, R. (2006). The Turbidity Tube : Simple and Accurate Measurement of Turbidity in the Field. *University of Virginia*. Retrieved April, 2018, <https://www2.virginia.edu>

- Navarro-Ortega, A., Acuña, V., Bellin, A., Burek, P., Cassiani, G., Choukr-Allah, R., & Barceló, D. (2015). Managing the effects of multiple stressors on aquatic ecosystems under water scarcity. The GLOBAQUA project. *Science of the Total Environment*, 503–504 (April 2014), 3–9. <https://doi.org/10.1016/j.scitotenv.2014.06.081>
- NBS. (2009). National Environmental Standards Compendium .National Bureau of Statics.Retrieved September 8, 2018.<https://www.nbs.go.tz>.
- Ngereza, A. (2005). Water and Environment in Tanzania: A Case of Pangani River Basin. *FWU Topics of Integrated Watershed Management Proceedings - Ngereza Summer School*, 3(10), 109–115.
- Nidhra, S., & Dondeti, J. (2012). Black box and white box testing techniques – a literature review. *International Journal of Embedded Systems and Applications*, 2(2), 29–50.Retrieved December 10,2018, <http://www.pdfsemanticscholar.org>.
- Oosthuizen, N., Hughes, D., Kapangaziwiri, E., Mwenge Kahinda, J., & Mvandaba, V. (2018). Quantification of water resources uncertainties in the Luvuvhu sub-basin of the Limpopo river basin. *Physics and Chemistry of the Earth*, (April 2017), 1–7. <https://doi.org/10.1016/j.pce.2018.02.008>
- Paseltiner, D., Payagala, S., & Jarrett, D. (2017). Design, Construction, and Calibration of a Temperature Monitoring System for Resistance Standards, *122(45)*, 1–9.
- Patil, K., Patil, S., Patil, S., & Patil, V. (2015). Monitoring of Turbidity, PH & Temperature of Water Based on GSM, (3), 16–21.
- Plekhanova, J. (2009). Evaluating web development frameworks: Django, Ruby on Rails and CakePHP. *Institute for Business and Information Technology*, (September), 20.
- Prasad, A. N., Mamun, K. A., Islam, F. R., & Haqva, H. (2015). Smart Water Quality Monitoring System, (December). <https://doi.org/10.1109/APWCCSE.2015.7476234>
- Prithwiraj, P., & Budhaditya, B. (2013). *Electrical and Electronics Measurements and Instrumentation*. McGraw Hill Education (India) Private Limited. Retrieved from <http://lrf.fe.uni-lj.si>
- Provalis. (2018). QDA Miner Tutorials and Demos. Retrieved November 3, 2018, from <https://provalisresearch.com/resources/tutorials/>

- Pule, M., Yahya, A., & Chuma, J. (2017). Wireless sensor networks: A survey on monitoring water quality. *Journal of Applied Research and Technology*, 15(6), 562–570. <https://doi.org/10.1016/j.jart.2017.07.004>
- Rahnema, M. (2009). *UMTS Network Planning, Optimization, and Inter-Operation with GSM. UMTS Network Planning, Optimization, and Inter-Operation with GSM.* <https://doi.org/10.1002/9780470823033>
- Ramya, C. M., Shanmugaraj, M., & Prabakaran, R. (2011). Study on ZigBee technology. *International Conference on Electronics Computer Technology*, 297–301. <https://doi.org/10.1109 /ICECTECH.2011.5942102>
- Rigelsford, J. (2003). *GSM Networks: Protocols, Terminology and Implementation. Sensor Review* (Vol. 23). <https://doi.org/10.1108/sr.2003.08723bae.001>
- Ruiz-garcia, L., Lunadei, L., Barreiro, P., & Robla, J. I. (2009). A Review of Wireless Sensor Technologies and Applications in Agriculture and Food Industry: State of the Art and Current Trends, (June). <https://doi.org/10.3390/s90604728>
- Seed. (2018). Grove - Temperature Sensor. Retrieved September 12, 2018, from [http://wiki.seeed studio.com/Grove-Temperature\\_Sensor\\_V1.2/](http://wiki.seeed studio.com/Grove-Temperature_Sensor_V1.2/)
- Segers, L. (2018). Study of Mount Meru, Internal Drainage Basin And Upper Pangani Basin, Tanzania, 2017–2018.
- Selemani, J. R., Zhang, J., Muzuka, A. N. N., & Njau, K. N. (2017). Seasonal water chemistry variability in the Pangani River basin, Tanzania Seasonal water chemistry variability in the Pangani River basin, Tanzania, (September). <https://doi.org/10.1007/s11356-017-0221-x>
- Shaghude, Y. W. (2015). Review of Water Resource Exploitation and Landuse Pressure in the Pangani River Basin Review of Water Resource Exploitation and Landuse Pressure in the Pangani River Basin, (March). <https://doi.org/10.4314/wiojms.v5i2.28510>
- Smile. (2018). Nition MiFi M028AT. Retrieved September 15, 2018, from <https://smile.co.tz/product/10gb-mifi-free-sim>
- Sohraby, K., Minoli, D., & Znati, T. (2007). *Technology Protocols and Applications.* <https://doi.org/10.1002/047011276X>

- Soto-Garcia, M., Del-Amor-Saavedra, P., Martin-Gorriz, B., & Martínez-Alvarez, V. (2013). The role of information and communication technologies in the modernisation of water user associations' management. *Computers and Electronics in Agriculture*, 98, 121–130. <https://doi.org/10.1016/j.compag.2013.08.005>
- Sotomayor, G., Hampel, H., & Vázquez, R. F. (2018). Water quality assessment with emphasis in parameter optimisation using pattern recognition methods and genetic algorithm. *Water Research*, 130, 353–362. <https://doi.org/10.1016/j.watres.2017.12.010>
- Srikanth, K. S. V. K. (2014). Research on HTML5 in Web Development, 5(2), 2408–2412.
- TCRA. (2017). *April- June 2017 Quarter*. Dar es Salaam.
- UNDP. (2013). United Nations Development Programme Country Tanzania. Strengthening climate information and early warning systems in Tanzania for climate resilient development and adaptation to climate change. UNDP Outcome ( s ) 1 ) C.
- UNEP. (2017). United Nations Environment Programme The Committee of Permanent Representatives to UNEP Briefing Session – Time : 10 : 00am – 12 : 00pm Gigiri , UN Office at Nairobi Conference Room 4 United Nations Environment Programme 15 March 2017 The Committee of Per, (March), 10–13.
- Vijayakumar, N., & Ramya, R. (2015). The real time monitoring of water quality in IoT environment. *International Conference on Circuits, Power and Computing Technologies*, 1–4. <https://doi.org/10.1109/ICCPCT.2015.7159459>
- Voigt, B. J. J. (2004). Dynamic System Development Method. Retrieved January 15, 2018
- Wang, N., Zhang, N. & Wang, M. (2006). Wireless sensors in agriculture and food industry Recent development and future perspective, 50, 1–14. <https://doi.org/10.1016/j.compag.2005.09.003>
- Wang, X., Ma, L., & Yang, H. (2011). Online water monitoring system based on ZigBee and GPRS. *Procedia Engineering*, 15, 2680–2684. <https://doi.org/10.1016/j.proeng.2011.08.504>
- Weber, S. (2012). Comparing Key Characteristics Of Design Science Research As An Approach and Paradigm.

- Wu, Z., Xiao, H., Lu, G., & Chen, J. (2015). Assessment of climate change effects on water resources in the yellow river basin, China. *Advances in Meteorology*, 2015, 8–12. <https://doi.org/10.1155/2015/816532>
- Yinbiao, S., Lanctot, P., Hao, H. & Desbenoi, L. H. (2014). Internet of Things : Wireless Sensor Networks Executive summary. Retrieved from <https://www.iec.ch/whitepaper/pdf/iecWP-internetofthings-LR-en.pdf>
- Zafar, A., Islam, N., & Ahmed, Z. (2014). Computer Standards & Interfaces A review of wireless sensors and networks applications in agriculture. *Computer Standards & Interfaces*, 36(2), 263–270. <https://doi.org/10.1016/j.csi.2011.03.004>
- Zakaria, Y., & Michael, K. (2017). An Integrated Cloud-Based Wireless Sensor Network for Monitoring Industrial Wastewater Discharged into Water Sources, 290–301. <https://doi.org/10.4236/wsn.2017.98016>
- Zhang, D., Wei, Z., & Yang, Y. (2013). Research on lightweight MVC framework based on spring MVC and mybatis. *International Symposium on Computational Intelligence and Design*, 1, 350–353. <https://doi.org/10.1109/ISCID.2013.94>

## APPENDICES

### Appendix 1 : Django Python Code Innovative Secure Water Quality Monitoring System Using Remote Sensor Code

```
from mysite.models import Sensor,Site,UserProfile,Employee,MonthlyWeatherByCity
from mysite.table import SensorTable
from django_tables2 import RequestConfig
from graphos.sources.model import ModelDataSource
from graphos.renderers import flot
from graphos.sources.simple import SimpleDataSource
from graphos.renderers.gchart import LineChart,AreaChart,BarChart,PieChart
#from water.water import settings
from googlevoice import Voice
#from googlevoice.util import input
import nexmo
from base64 import b64decode
from base64 import b64encode
from Crypto.Cipher import AES
from Crypto.Util.Padding import pad
from Crypto.Random import get_random_bytes
import base64
from Crypto.Util.Padding import unpad
from chartit import DataPool, Chart
from mysite.render import Render
def login_redirect(request):
    return redirect('login.html')
def DashboardView(request):
    # client = nexmo.Client(key='77250fc4', secret='U0xOkm3xkQHjY6iQ')
    # client.send_message({
    #     'from': 'IWQMSRS',
    #     'to': '255753770765',
    #     'text': 'pH is 9 at Nambala site INTERVENTION IS NEEDED',
    # })
```

```

queryset =
Site.objects.all().values('sitename','sensor__pH','sensor__TEMPerature','sensor__turbidity','se
nsor__dissolved_oxygen','sensor__sensor_location','sensor__time').order_by('-sensor__time')
try:
    queryset_pH = Site.objects.all().values_list('sensor__pH').order_by('-sensor__time')
    # queryset_TEMP = Site.objects.all().values_list('sensor__TEMPerature').order_by('-
sensor__time')
    queryset_DO= Site.objects.all().values_list('sensor__dissolved_oxygen').order_by('-
sensor__time')
    tiqueryset_turb = Site.objects.all().values_list('sensor__turbidity').order_by('-
sensor__time')
    list_PH=[]
    list_TEMP=[]
    list_DO=[]
    list_turb=[]
    for pH in queryset_pH:
        key = get_random_bytes(16)
        cipher = AES.new(key, AES.MODE_CBC)
        iv = b64encode(cipher.iv).decode('utf-8')
        iv = base64.b64decode(iv)
        cipher_queryset2= base64.b64decode(pH)
        cipher = AES.new(key, AES.MODE_CBC, iv)
        plaintext_queryset2 = unpad(cipher.decrypt(cipher_queryset2), AES.block_size)
        real_plaintext = (plaintext_queryset2.decode('utf-8'))
        list_PH.append(real_plaintext)
    for TEMP in queryset_TEMP:
        key = get_random_bytes(16)
        cipher = AES.new(key, AES.MODE_CBC)
        iv = b64encode(cipher.iv).decode('utf-8')
        iv = base64.b64decode(iv)
        cipher_queryset_TEMP= base64.b64decode(TEMP)
        cipher = AES.new(key, AES.MODE_CBC, iv)
        plaintext_queryset_TEMP = unpad(cipher.decrypt(cipher_queryset_TEMP),

```

```
AES.block_size)
    real_plaintext_TEMP = (plaintext_queryset_TEMP.decode('utf-8'))
except:
    incorrect= 'incorrect description'
context={
    'displaylist':queryset
}
```



## **Appendix 2 : Interview Guide**

### **THE NELSON MANDELA AFRICAN INSTITUTION OF SCIENCE AND TECHNOLOGY (NM-AIST)**

#### **INTRODUCTION OF RESEARCH**

Our research focuses on developing remote sensing systems that will monitor quality of water in the river basin. To achieve the research objectives, we need to study and understand the existing systems in the river basins and identify crucial challenges on monitoring the quality of water in river basins in Tanzania. Understanding the challenges will help in proposing and developing a new system for monitoring the quality of water in river basins in Tanzania.

This research is under supervision of Nelson Mandela African Institution of Science and Technology (NMAIST) and will be used as a requirement to fulfil Master's degree.

#### **WATER SOURCES PANGANI RIVER BASIN**

1. What are the types of water sources in Pangani River basin?
2. Can you provide the documents/maps regarding locations of different water sources in Pangani river basin?
3. Can you provide the quantity of water (volume) saved by water sources?
4. How old are the water sources infrastructures in Pangani river basin?
5. What are the methods do you use to maintain the water sources to ensure quality of water are not compromised?
6. How do you deal with variations of quality of water sources?
7. How do you maintain the safety of water sources?
8. Mention other challenges faced by water sources in the basin?

#### **MONITORING AND MANAGEMENT OF WATER SOURCES IN THE BASIN**

1. What are important water quality parameters monitored in the water sources?

**Please share documents or collected data if available**

2. What are the types of Equipments used in measurement of mentioned parameters?

If **Equipments** are **Digital**, please list which parameters are measured.

If **Equipments** are **Analog**, please list which parameters are measured.

3. What are the parameters used in measuring quality of water in the sources?
4. Do you have water resources information system in the basin?

If yes

5. What are the functional blocks of the mentioned system?

**Please provide the conceptual design of the existing system**

6. What are the technical specifications of Water resources information system?

Considering task, operating environment, human machine interaction, sensors and others?

7. How is the mentioned information system integrated with Equipment in the water sources?
8. Is the system capable of monitoring real-time information from the water sources?
9. Mention challenges faced by water resources information system in the basin?

### **DECISION MAKING PARAMETERS ON AVAILABILITY AND QUALITY IN THE BASIN**

1. What are the key performances indicators of quality of water sources in the basin both long- and short-term basis considering environmental flow management and climate?
2. Mentioned the boundary values allowed or disallowed when measuring quality and quantity of water in the basin?

### Appendix 3 : Data Collection Introductory Letter

Kaizilege Mwemezi,  
P.O.Box 7109,  
Dar es Salaam,  
Tanzania.  
12<sup>th</sup> February 2018.

Dean School of CoCSE,  
NM-AIST,  
P.O. Box 447,  
**Arusha.**

Dear Sir/Madam

**RE: REQUEST FOR INTRODUCTORY LETTER TO COLLECT DATA AT  
PANGANI LOWER BASIN**

My name is Kaizilege Mwemezi, studying Master of Information and communications engineering and science (ICSE) with registration number (M.348/T16).

I am requesting for introductory letter to collect data at Pangani Lower basin as case study of my research entitled **Innovative Secure Water Quality Monitoring System using Remote Sensors.**

I hope my request will be accepted.

Yours sincerely .....

**Kaizilege Mwemezi  
Student.  
Email:mwemezika@nm-aist.ac.tz  
Mob:0753280921**

## Appendix 4 : The Research Approval Letter

THE NELSON MANDELA  
AFRICAN INSTITUTION OF SCIENCE AND TECHNOLOGY  
(NM-AIST)

School of Computational and Communication Science and Engineering

Direct Line: +255 272970001  
Fax: +255 272970016  
E-mail: joseph.mwangoka@nm-aist.ac.tz



Tengeru  
P.O. Box 447  
Arusha, TANZANIA  
Website: [www.nm-aist.ac.tz](http://www.nm-aist.ac.tz)

OUR Ref. No. NM-AIST/M. 348/T.16/5

Date: 13<sup>th</sup> February, 2018

To Whom It May Concern,

Dear Sir/Madam,

**RE: INTRODUCTION TO KAIZILEGE MWEMEZI**

Kindly refer to the above heading.

I wish to introduce Kaizilege Mwemezi with Registration No. NM-AIST/M.348 who is a Masters student at Nelson Mandela African Institution of Science and Technology, School of Computational and Communication Science and Engineering. As part of the requirement for Master's degree, Kaizilege is undertaking a research with title "*Water Monitoring System for Decision Support*"

In order to accomplish the research objectives, he would like to collect some information from your Institution/Organization. The information collected will be used only for research purposes and will give a picture on the issue of **Water Monitoring System**" in Tanzania as it states in the research objectives.

It is my sincere hope you will assist the student in accomplishing his study.

Looking forward to your cooperation.

Yours Sincerely,

Dr. Michael Kisangiri  
Ag. Dean COCSE

Nelson Mandela African Institute  
of Science and Technology  
(NM-AIST - ARUSHA)  
P. O. Box 447  
Tengeru  
Tel: +255 27 2555070  
Fax: +255 27 2555070

## Appendix 5 : Java Script, HTML and Python Code For Web Application

```
{% load static %}
<!DOCTYPE html>
<html lang="en">
<head>
  <meta charset="utf-8">
  <meta http-equiv="X-UA-Compatible" content="IE=edge">
  <meta name="viewport" content="width=device-width, initial-scale=1, shrink-to-fit=no">
  <meta name="description" content="">
  <meta name="author" content="">
  <title>SB Admin - Start Bootstrap TEMPlate</title>
  <!-- Bootstrap core CSS-->
<link href="{% static 'vendor/bootstrap/css/bootstrap.min.css'%}" rel="stylesheet ">
  <!-- Custom fonts for this TEMPlate-->
  <link href="{% static 'vendor/font-awesome/css/font-awesome.min.css'%}" rel="stylesheet"
type="text/css ">
  <!-- Page level plugin CSS-->
  <link href="{% static 'vendor/datatables/dataTables.bootstrap4.css '%}" rel="stylesheet'
%}">
  <!-- Custom styles for this TEMPlate-->
  <link href="{% static 'css/sb-admin.css'%}" rel="stylesheet ">
  <link href="{% static 'css/wql.css' %}" rel="stylesheet">
</head>
<body class="clogin">
  <!-- Navigation-->
  <nav class="navbar navbar-expand-lg navbar-dark bg-dark fixed-top" id="mainNav">
    <a class="navbar-brand" href="{% url 'index' %}">WATER QUALITY MONITORING
AND MANAGEMENT SYSTEM</a>
    <button class="navbar-toggler navbar-toggler-right" type="button" data-toggle="collapse"
</li>
    <li class="nav-item" data-toggle="tooltip" data-placement="right" title="Tables">
    <a class="nav-link" href="{% url 'pdf' %}">
```

```

        <i class="fa fa-fw fa-table"></i>
        <span class="nav-link-text">WQ Report</span>
    </a>
</li>
user-row {
    margin-bottom: 14px;
}
.user-row:last-child {
    margin-bottom: 0;
}
.dropdown-user {
    margin: 13px 0;
    padding: 5px;
    height: 100%;
}
.dropdown-user:hover {
    cursor: pointer;
}
.table-user-information > tbody > tr {
    border-top: 1px solid rgb(221, 221, 221);
}
.table-user-information > tbody > tr:first-child {
    border-top: 0;
}
.table-user-information > tbody > tr > td {
    border-top: 0;
}
.toppad
{margin-top:20px;
}
* MIT license */
var colorNames = require(5);

```

```
module.exports = {
  getRgba: getRgba,
  getHsla: getHsla,
  getRgb: getRgb,
  getHsl: getHsl,
  getHwb: getHwb,
  getAlpha: getAlpha,
  hexString: hexString,
  rgbString: rgbString,
  rgbaString: rgbaString,
  percentString: percentString,
  percentaString: percentaString,
  hslString: hslString,
  hslaString: hslaString,
  hwbString: hwbString,
  keyword: keyword
}
function getRgba(string) {
  if (!string) {
    return;
  }
}
```