

2009

Innovations and Sustainability: The Case of Improved Biomass Stoves' Adoption and Use in Tanzania

Rwiza, Mwemezi

Lund, Sweden – Spring

<http://dspace.nm-aist.ac.tz/handle/123456789/327>

Provided with love from The Nelson Mandela African Institution of Science and Technology



LUMES Lund University International Master's Programme
in Environmental Studies and Sustainability Science

Innovations and Sustainability: The Case of Improved Biomass Stoves' Adoption and Use in Tanzania



Author:

Mwemezi Rwiza

Magistratvägen 55 U 111

226 44 LUND

Sweden

Email: [@yahoo.com](mailto:rwiza@yahoo.com)

Submitted for partial fulfillment of the requirements for LUMES, Lund University International Master's Programme in Environmental Studies and Sustainability Science

Supervisor:

Sara Brogaard

LUCSUS, Lund University Centre for Sustainability Studies

Geocentrum 1, Sölvegatan 10, P.O. Box 170

SE-221 00 LUND Sweden

Tel +46 46 2220512,

E-mail: [.brogaard@lucsus.lu.se](mailto:sbrogaard@lucsus.lu.se)

Lund, Sweden – Spring 2009.

Abstract

The adoption and continued use of improved stoves in the developing countries is of social, economic and environmental concern. In most developing countries, biomass-based energy accounts for more than 90% of all household energy consumption. It is estimated that each year indoor air pollution is responsible for the death of 1.6 million people in dwellings that are poorly ventilated – approximately one death in every 20 seconds. Recent studies are increasingly showing that black carbon, mainly from open and residential burning of biomass, is altering the reflective ability of the atmosphere and ice surfaces hence exacerbating global warming. The invention and diffusion of improved stoves in developing countries is therefore perceived as instrumental in the efforts to combat the negative effects related to the use of traditional hearths. The overall aim of this study was to explore the problems that stove users face after adoption of improved stoves and to suggest what could possibly be done to overcome those problems.

In this study a total of 26 stove users, non-users and promoters in Tanzania were interviewed using *semi-structured*, *unstructured* and *focused interview* methods. Results indicate that, at the field level; lack of appropriate projects' evaluation, inadequate grassroots (end-users) involvement, capability problems, as well as stoves' own technical faults and inflexibility are highly undermining the diffusion efforts. In practice; women who are the primary users of stoves are either passively or partially involved in the diffusion process. At the policy-making level; the government is yet to make stove programs a priority and has settled for the NGO-led dissemination efforts. Results from this study will be a useful contribution for researchers, policy makers, NGOs and groups involved in promoting the adoption and use of more sustainable innovations.

Keywords: Adoption, indoor air pollution, sustainable innovations, improved stoves, Tanzania, energy, firewood, TaTEDO

TABLE OF CONTENTS

1. Introduction.....	6
1.1. Wood-burning technologies and sustainability.....	6
1.2. Analytical framework and aim.....	7
1.3. Relevance and intended contribution.....	8
2. Background.....	8
2.1. The situation of the energy sector in Tanzania	8
2.2. Stove programs, development and the environment.....	10
2.3. Tanzania Traditional Energy Development Organization	13
2.4. The setting.....	13
3. Theory and methodological considerations	15
3.1. Theoretical framework.....	15
3.2. Methodological considerations	20
4. Results	21
4.1. Interview results.....	21
4.2. Field observation.....	24
4.3. Documentary search.....	24
5. Findings and discussion	24
5.1. Stove adoption – the system drivers	24
5.2. User’s perception of the benefits	26
5.2.1. Wood-saving	26
5.2.2. Economy rather than the environment.....	27
5.2.3. Easier and faster cooking	27
5.2.4. Heat conservation.....	27
5.3. Technological capabilities, technical and institutional aspects.....	28
5.3.1. Not improvement but alternative	28
5.3.2. Improved but not clean?.....	29
5.3.3. Improved but not smokeless	29
5.3.4. Housing type versus stove used	31
5.4. Parallel use of both – reasons.....	31
5.5. The gender side of improved stoves	34
5.6. Conceptualizing abandonment: The Bridge to Abandonment.....	34
6. Conclusion and recommendations.....	35
7. Bibliography	39
Internet/Web resources:	43
8. Appendices.....	44
A: Interview schedule for improved stove users.....	44
B: Interview schedule for former users who abandoned the stove	44
C: Interview schedule for non-users:	44
D: Sample of interviews with key questions and answers from respondents	45

List of tables

1: Summary of the interview results.....	22
--	----

List of figures

1: The proportion of the population with and without access to electricity in Tanzania.....	9
2: Combustion sources of black carbon	12
3: Map of Tanzania showing the villages where the study was conducted	14
4: Schein’s “group problem solving” model: the role of stakeholder involvement in technology diffusion	18
5: The Energy Ladder or Pyramid.....	19
6: Two types of stoves commonly encountered in the field: A = Low-cost stove found in rural areas; B = High-cost stove found in peri-urban and urban areas	23
7: Factors affecting the stove adoption and use system	25
8: The two types of chimney: metal and brick in Sanya-juu village.....	30
9: Maize hanging over the traditional stove in Kuze-Kibago village	33
10: The bridge to improved stove abandonment.....	35

Acknowledgements

I would like to express my gratitude to the institutions and people who made my field and thesis work a great success. My heart-felt vote of thanks goes to my supervisor, Sara Brogaard at Lund University who has been always there when I needed help. My thanks also extend to the Swedish International Development Cooperation Agency (SIDA) without whose financial assistance and support it would have been impossible to study in Sweden and conduct my research in Tanzania. Many thanks also to Wang Jiehui for her encouragement and relentless efforts in proofreading the text to ensure coherence.

I would also like to thank TaTEDO as an organization and its staff in particular for all the support I received from them since the day I expressed my ambition to study about improved stoves in Tanzania. I would, specifically, want to say a thank-you to Witness Bwenge who tirelessly did whatever she could to make sure my endeavour becomes a success. I am also thankful to Mr. Thomas Patrick Mkunda and Mr. Emmanuel Benjamin at TaTEDO Northern Zone office who offered me a lot more than I expected as a support from them. Special thanks to Exper Pius, a friend and colleague at Muheza township who was not only willing to open the doors for me to stay at his house while I was in Muheza but who also opened doors to enable me go to Kuze-Kibago village and conduct my interviews in Muheza District. Andrew Ferdinands: your cooperation and assistance to come up with the map of

Tanzania showing my three villages was invaluable. It is difficult to mention each and everyone who supported me in this quest, in one way or another, but these few words are a token of my sincere gratitude to all of you.

List of acronyms and abbreviations

AWC	Angaza Women Centre
CBOs	Community-based Organizations
EAMCEF	Eastern Arc Mountains Conservation Endowment Fund
ELCT	Evangelical Lutheran Church of Tanzania
IFS	Improved Fuelwood Stove
LPG	Liquefied Petroleum Gas
MDC	Muheza District Council
MDGs	Millennium Development Goals
MEWM	Ministry of Energy, Water and Minerals
NBS	National Bureau of Statistics
NGOs	Non-governmental Organizations
NSGRP	National Strategy for Growth and Reduction of Poverty
R&D	Research and Development
SIDA	The Swedish International Development Cooperation Agency
TAS	Tanzania Shillings (currency)
TaTEDO	Tanzania Traditional Energy Development Organization
TFCG	Tanzania Forest Conservation Group
US\$	United States dollar (currency)
WHO	World Health Organization
WSSD	World Summit on Sustainable Development

“Urging these villagers to make roti in a solar cooker meets the same mix of rational and irrational resistance as telling an Italian that risotto tastes just fine if cooked in the microwave.”

[*New York Times*’ (Rosenthal, 2009)]

1. Introduction

1.1. Wood-burning technologies and sustainability

Issues concerning technologies that use biomass for cooking, heating and lighting have been on the global scientific and political agenda for many years. Traditional wood-burning technologies are known to cause harm to both the environment and humans. To solve the problems related to inefficient wood-burning technologies many approaches have been put into action. In developing countries the common approach has been the introduction of improved stoves. Proponents of improved woodstove technologies claim that improved stoves offer social, environmental and economic benefits (Barnes *et al.*, 1993; Barnes *et al.*, 1994). Improved stoves are said to reduce indoor air pollution and hence save lives of women and children who would otherwise suffer respiratory problems and other infections by using traditional stoves (Bruce *et al.*, 2000; WHO, 2005). Improved stoves are also promoted for their alleged increased energy efficiency hence reducing fuelwood consumption. Berrueta, in his study in Mexico, for example, gives an average reduction in fuelwood consumption of 67% (Berrueta *et al.* 2008).

The World Summit on Sustainable Development (WSSD) pointed out access to affordable and reliable energy as key to halving poverty by 2015. WSSD laid down several strategies through which this access can be achieved. One among these strategies was to “*promote a sustainable use of biomass by encouraging more efficient use of fuelwood and new or improved products and technologies*” (see United Nations, 2002, p.11). But as Spalding-Fecher *et al* say, promoting access to energy, while making a transition to a cleaner energy future at the same time is a challenge (Spalding-Fecher *et al.* 2005, p.100). Lack of access to affordable, reliable and cleaner energy is also known to have a negative impact on the social well-being in most developing countries (United Nations, 2009). For development to be sustainable the needs of the present generation should be met without compromising the ability of future generations to meet their own needs. However, energy needs of the developing world have to be met in a sustainable manner. The sustainability of the current path which involves traditionally accessing and using energy sources in most developing countries is highly questionable. The social and

environmental impacts related to traditional energy practices are negatively affecting the efforts to alleviate poverty. Disease burden posed by indoor air pollution, for example, is costing many governments in the developing countries billions of dollars which could be used on other developmental projects hence hampering their efforts to bring about development (PCIA, 2009). In countries like Tanzania for instance, reliance on solid fuels is one of the 10 most important threats to public health (Rehfuess, 2007). Evidence linking solid fuel use in developing countries to climate change is slowly but strongly building up and there are growing concerns that inefficient biomass burning may be contributing significantly to global warming (Crutzen & Andreae, 1990; Smith *et al.*, 1993; Sagar, 2005; Venkataraman *et al.*, 2005; Johnson *et al.*, 2008; Worldwatch Institute, 2009). Adoption and continued (sustained) use of improved biomass stoves in developing countries is therefore a sustainable development case.

1.2. Analytical framework and aim

Through a qualitative strategy, this study aims to analyze and discuss phenomena that surround the adoption and continued use of more sustainable technologies by focusing on one of these technologies – improved woodstoves. Underneath this analysis is the ambition to deepen the existing knowledge and understanding of post-adoption dynamics in the diffusion of such innovations. The aim and questions guiding the analysis are stated out below.

The overall aim of my study was to explore the problems that stove users face after adoption of improved stoves and to suggest what could possibly be done to overcome those problems. A lot of success stories have been published with regard to the use and advantages of improved fuelwood stoves (IFS). What we do not hear much about, however, are failure stories – problems encountered during and after the dissemination. This study sets out to examine both the successes and the limitations of the adoptive use of improved stoves, and to draw some lessons from the analysis. The overall research question is: Why is the widespread adoption of improved stoves in Tanzania so limited despite their social, economic and environmental benefits? Based on this question, I have formulated the following more specific research questions:

- i. Why do people adopt improved stoves?
- ii. Do people continue to use improved stoves after adoption?
- iii. Why do adopters continue to use improved stoves?

iv. Why do some users abandon improved stoves after adoption?

These questions will be used to guide the entire study. They will gauge the benefits of improved stoves and act as a framework through which adoption and post-adoption issues can be measured.

1.3. Relevance and intended contribution

This study intends to broaden the knowledge on issues and factors that may positively or negatively affect the adoption and continued use of improved stoves. Some of the information and findings gathered through this study can be a contribution in the field of diffusion of (more) sustainable innovations. Through this study, I expect to identify some factors that could be a hindrance to widespread adoption of improved stoves in the context of Tanzania. Data and findings presented in this work can be of help to individuals, organizations, policy makers and institutions as they endeavor to disseminate the technology. Although there are many stove programs in developing countries, there are however not many evaluation studies on those stove programs. This study, therefore, will also be a contribution to the growing body of research in the area of stove programs evaluation.

2. Background

2.1. The situation of the energy sector in Tanzania

Tanzania, the largest country of East Africa, covers 940,000 square kilometers. According to the National Bureau of Statistics (NBS) and the information on the government website¹, by the year 2002 the population of Tanzania was 34.4 million of which 23.1 percent lived in urban areas. As Figure 1 below depicts the percentage of the population with access to electricity in Tanzania is only 7%, the rest depend on biomass as their main source energy (NBS , 2005; Odhiambo, 2009, p.618). In their 1995 study on the dissemination and use of improved stoves in the Eastern Africa region, Karekezi and Turyareeba give a relatively similar figure of the percentage of the population which depends on biomass energy in Tanzania – 92% (see Karekezi & Turyareeba, 1995, p.12).

¹ The Tanzania Government website: <http://www.tanzania.go.tz/>

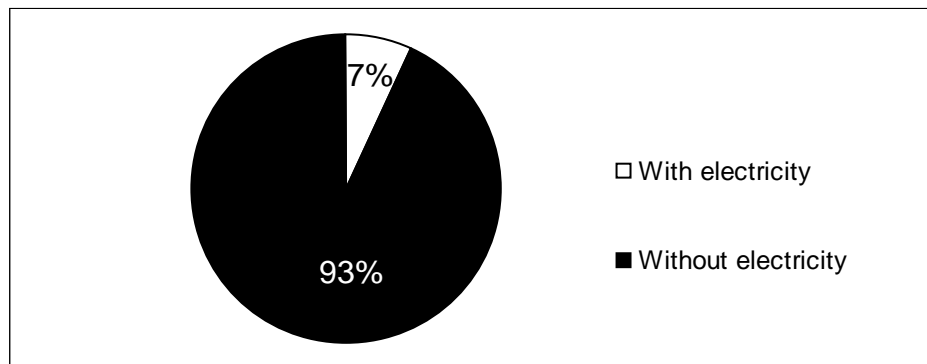

Figure 1: The proportion of the population with and without access to electricity in Tanzania
(Source: Adapted from NBS 2005)

Of the population that live in urban areas in Tanzania, only 38.4 percent have access to electricity whereas only 1.3% of the rural population have access to electricity (NBS 2005, *ibid*). Biomass energy can be used in its various forms: firewood, charcoal, crop residue and animal dung. Irrespective of the form used, users need a stove in which to burn the biomass. Therefore there are different shapes and sizes of biomass stoves depending on: 1) the type of biomass used and 2) the efficiency of the stove. It is therefore not unusual to encounter several types of biomass stoves in the field – firewood, charcoal, residue, dung, traditional stove and/or improved stove.

There have been attempts by the government, local and international NGOs, and donor agencies to try and remedy the energy situation in the country. But these strategies either ended up being as files in shelves in the ministers’ offices or as well-meaning projects that never took off. The 1992 National Energy Policy document (reviewed in 2003) recognizes biomass as the main energy source for the majority of the country’s population. It is postulated, however, in the same document that continued reliance on biomass is not sustainable in the long run as “*the forest areas are harvested at a rate faster than the regeneration of forests*” (MEWM, 1992, p.4). This policy document set nine overall goals of the Tanzanian National Energy Policy of which one was “*to arrest woodfuel depletion by evolving more appropriate land management practices and more efficient woodfuel technologies*” (MEWM 1992, p.5, *ibid*). The goals were, however, seen to be long-term and so the document also set out several short- and medium-term strategies. These included: “*generation and distribution of electricity at affordable prices and commensurate with demand, and development and dissemination of efficient*

woodfuel conversion and utilization technologies and introduction of coal stoves for domestic purposes in order to reduce the depletion of wood” (p.6). Thirteen years after the energy policy document was published, neither the goals nor the strategies stipulated in the document were anywhere close to being reached. So in 2005 the government in collaboration with the donor community launched the National Strategy for Growth and Reduction of Poverty (NSGRP).

NSGRP just like the documents that preceded it identifies access to reliable energy as the engine of economic growth. It also goes further to stipulate how unreliable and high-cost energy has undermined the country’s efforts to reach the Millennium Development Goals (MDGs). The document points out that to achieve the MDGs access to reliable energy is a prerequisite (NSGRP, 2005, p.8). A highly ambitious target is set to reduce the proportion of rural and urban “*population depending on biomass energy for cooking from 90 percent in 2003 to 80 percent in 2010*” (*ibid*: p.41). Only time will reveal whether these targets to achieve energy reliability and eradicate poverty will be reached.

For the urban population in Tanzania, the preferred type of biomass as energy source is charcoal. Rural people, depending on their availability, will use firewood, crop residues, animal dung or a combination of those (*personal experience*, MEWM 1992, p.15, *ibid*). The above mentioned biomass types can be used either in a traditional or in an improved stove. The core subject of this study was to investigate the adoption and use of improved biomass stoves in Tanzania regardless of the type of biomass they use. The use of improved stoves in Tanzania is not a new phenomenon. Some records show that improved biomass stoves have been in use in Tanzania as far back as 1984 (Sneiders 1984 in Gill 1987). The 1991 data indicates that only 54000 urban households were using improved stoves at that time (Karekezi & Majoro, 2002, p.1025).

2.2. Stove programs, development and the environment

In a World Bank technical paper on stove programs, Barnes *et al* assert that the use of improved stoves could lead to improvement in people’s livelihoods. By using improved stoves the paper points out that users’ time could be saved. Because of the stove’s improved efficiency, it is alleged, time used to perform cooking activities is reduced. It is also argued that the use of improved stoves could lead to reduced workload on women and children in developing countries as less amount of firewood is needed

when using an improved and more efficient stove (Barnes *et al.* 1994, p.vii; also see Barnes *et al.* 1993).

The two classes of benefits that are at the core of most improved stoves programs are their environmental/health and socioeconomic impacts. Reduced firewood consumption also positively impact the environment as less wood resources will be harvested thereby reducing pressure on these natural resources. This was actually the push behind stoves programs in the 1970s. The agenda of improved stoves programs of the 1970s and early 1980s was the concern about the environment – to combat deforestation and desertification. Accordingly, improved stove projects at that time were run by forestry experts with no (or little) interest in the kitchen or end-users (Barnes *et al.*, 1994; Barnes *et al.*, 1993; Nyström, 1994; Report3, 1993; Karekezi & Turyareeba, 1995).

The late 1980s and the 1990s saw a change in the focus of improved stoves programs. There was a shift in emphasis towards the socioeconomic impacts and benefits of improved stoves. Improved stoves became a social as well as an economic issue. It was postulated that, because improved cookstoves saved time used in cooking and consumed less firewood, they had the potential to improve users' livelihoods. Women, it was said, would spend less time in the kitchen and out in the woods collecting firewood. Accordingly the time saved could be used to engage in other income-generating activities. As improved stoves consumed less firewood, it was also thought that the local people could save money by using an improved stove, especially in areas where wood resources were scarce (Nystrom 1994; Report3 1993; Barnes *et al.* 1994; Gill 1987; Berrueta *et al.* 2008).

Another important shift in focus that has been seen with regards to improved stoves programs is the emphasis on the health benefits and health impacts of stoves. The (potential) health benefits of using improved stoves has, in recent years, been instrumental in bringing back the stoves as an item on the global sustainability agenda. The World Health Organization (WHO) estimates that more than half of the world's population depend on dung, wood, charcoal, crop residues or coal to meet their most basic energy needs. WHO continues to say that heating and cooking with these solid fuels on inefficient stoves has led to highly staggering indoor air pollution (IAP) figures. It is estimated that indoor smoke can exceed acceptable levels for small particles in outdoor air 100-fold in poorly ventilated dwellings. The number of deaths of women and children in developing countries caused by exposure to IAP in

developing countries is enormously high. Each year, exposure to IAP claims 1.6 million lives – that is one death in every 20 seconds. What is even more surprising is that despite the magnitude of the problem, “*the health impacts of exposure to indoor air pollution have yet to become a central focus of research, development aid and policy-making*” (WHO, 2005). Proponents of improved stoves assert that the use of the stoves could lead to a substantial decrease in indoor air pollution and hence save the lives of millions (Barnes *et al.* 1994, *ibid*).

Very recently, we have seen a new shift. There has been a renewed concern about stoves and cooking practices in developing countries. Scientists are finding a strong link between black carbon (soot) emissions and global warming (Worldwatch Institute, 2009). It is estimated that black carbon may rank second to CO₂ as a contributor to global warming. Furthermore it is postulated that reducing black carbon emissions could produce an almost immediate effect in lessening global warming as black carbon’s life-time in the atmosphere ranges between hours to a few days. It is apparently becoming more reasonable to encourage the use of efficient cookstoves as this may have an impact on the amount of black carbon emitted to the atmosphere. As figure 2 below shows, the main sources of black carbon are open burning of biomass, diesel engines, and the residential burning of solid fuels such as coal, wood, dung, and agricultural residues (Johnson *et al.*, 2008; Smith *et al.*, 1993; Crutzen & Andreae, 1990).

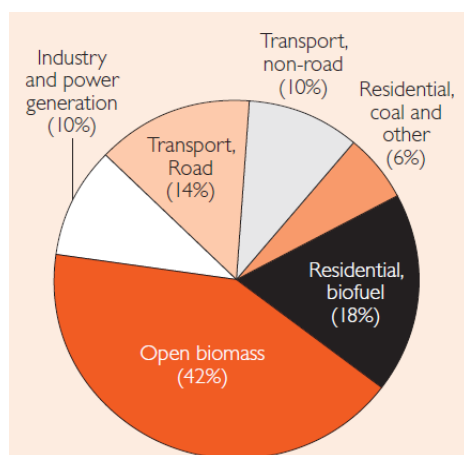

Figure 2: Combustion sources of black carbon
(Source: Worldwatch Institute, 2009)

2.3. Tanzania Traditional Energy Development Organization²

To accomplish my research ambition I partly worked with the Tanzania Traditional Energy Development Organization (TaTEDO) because the organization has for years dealt with sustainable energy-related works in the country. Currently, their activities cover 19 districts in eight regions in mainland Tanzania. Based in Dar es salaam, TaTEDO works with the government, other local and international NGOs, and donors in up-scaling access to sustainable modern energy and services in both rural and urban areas in Tanzania. Plans are underway to open more branches upcountry that will cover a wider area of the mainland Tanzania. The organization's overall objective is to contribute to poverty reduction and environmental conservation. Through its personnel, TaTEDO organizes training sessions and arranges awareness raising campaigns. Through these activities TaTEDO experts share and disseminate knowledge of various sustainable technologies to local artisans, technicians, churches, other local NGOs and the public at large.

2.4. The setting

I did my study in three villages in Tanzania. Two villages were in the peri-urban setting and one village was in a rural setting. A total of 26 respondents were interviewed using semi-structured and unstructured interviews. My respondents included stove users, non-users, stove technicians and experts (see Table 1 below).

I started by liaising with the Tanzania Traditional Energy Development Organization (TaTEDO) officials at their headquarters in Dar es salaam. My initial plan was to visit and do my study in villages, preferably in a typical rural setting, where improved stoves have been in use for ten years or more. But I was told that the 1990 stove projects were done in collaboration with other organizations and most of them were cross-border projects. This posed a difficulty in terms of logistics and so I had to alter my plans. My field visit objectives were 1) to see (observe) improved stoves at work 2) to interview users and non-users and learn from their experience, and 3) to interview innovation proponents of improved stoves, especially technicians and experts (stove designers). Thus TaTEDO, after considering my study objectives, suggested villages that I could work on. After that they sent me to their Northern Zone offices in Moshi, Kilimanjaro region. Here I met the staff who had been working in the villages which were suggested.

² The organization's website is: <http://www.tatedo.org/>

After the meeting in Moshi we came up with a plan of my village visits. Two villages were proposed: Sanya-juu and Magadini. These two villages are located about 40 kilometres from Moshi town (see the map, Figure 3 below), about an hour's drive away.

My set of interviewees in these two villages comprised of at least five types of stove users: (1) institutional stove users e.g. in schools, (2) household level stove users, (3) business stove users, (4) village stove technicians, and (5) TaTEDO officials/staff (expert). A total of 13 respondents were interviewed: seven household level stove users (home), three respondents used their stoves for business purposes, one school (institutional), one group meeting with village stove technicians and one TaTEDO official/staff (see table 1 below).

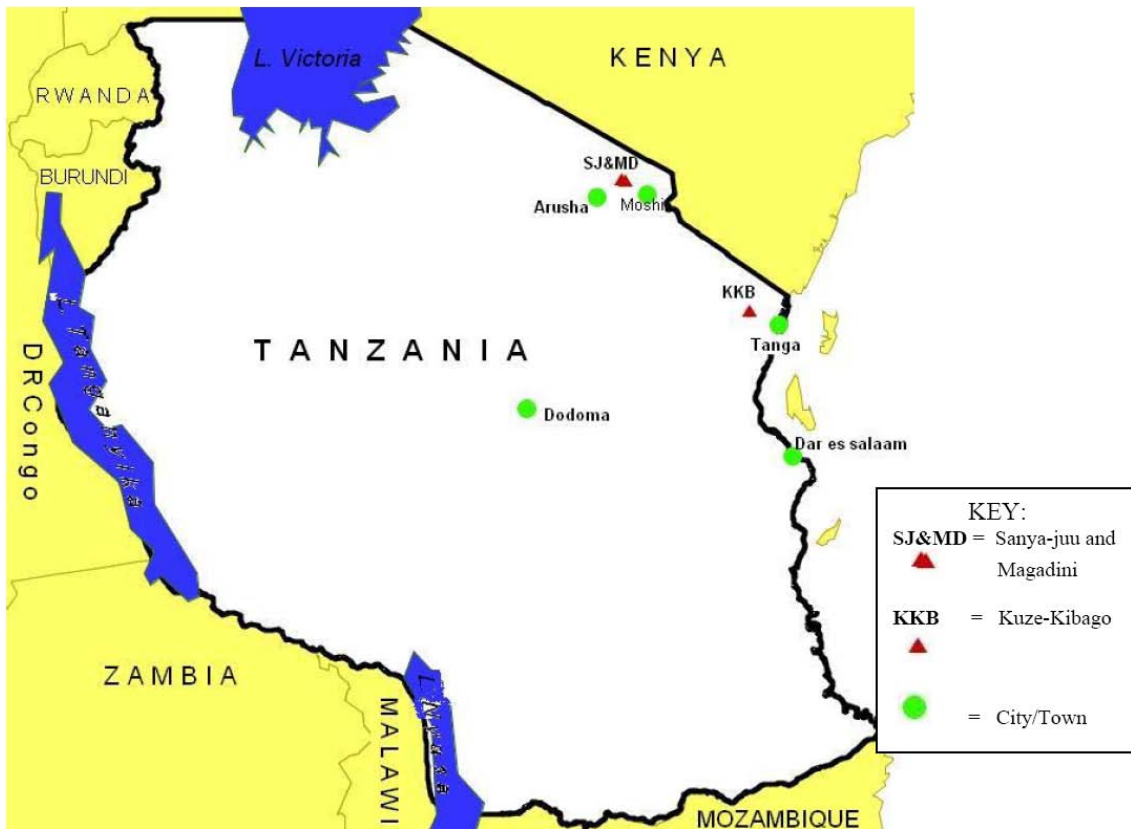

Figure 3: Map of Tanzania showing the villages where the study was conducted (Source: Rwiza, 2009³)

The data I gathered in Sanya-juu and Magadini villages was, however, characteristic of what could be termed as a typical *peri-urban* setting. Almost all the households I visited were relatively well-off

³ Acknowledgements to Andrew Ferdinands, a friend who assisted me with creating the map from my GPS points

families, not very rich but not poor either. They had good housing and it seemed they could afford almost all their basic life necessities. Demographic data of Sub-Saharan Africa indicate that this kind of households/people (living at or above the poverty line) represent only about 20% of the total population. The rest 80% are people who live in poor rural settings (Torero & Chowdhury, 2004; Birol, 2007, p.3). I was interested in making sense of this data in the context of a typical rural setting. So I made plans to extend my study to one more village.

Kuze-Kibago is a village located in Muheza District, about 100 kilometres away from the coastal city of Tanga and 60 kilometres from Muheza township (see the map above). This was a village in a typical rural setting. From its outlook it was not difficult to tell that at least 90% of its inhabitants lived below one dollar a day. Accompanied by a friend from Muheza township, we went to the village offices and introduced ourselves and our mission. We were also introduced to a guide who took us around to meet people who used improved stoves.

A total of thirteen people were interviewed in this location. The following is the categorization of users who were interviewed: one interviewee (village guide), one local stove expert, a group of local artisans/technicians, six home stove users, two interviewees used their stoves for business purposes and two respondents who did not use improved stoves at all – non-user (see table 1 below). The rural improved stove initiative in this village was not facilitated by TaTEDO. It was rather an initiative by the Muheza District Council (MDC) facilitated (funded) by the Eastern Arc Mountains Conservation Endowment Fund (EAMCEF) and the Tanzania Forest Conservation Group (TFCG).

3. Theory and methodological considerations

3.1. Theoretical framework

This study will be guided by three main theories: *diffusion of innovations* (Rogers, 1995), *stakeholder participation* in sustainable development projects (Bell & Morse, 2005; Bell & Morse, 2004) and sustainable *transitions* (Kemp et al., 2006; Nill & Kemp, 2009). Rogers defines diffusion as the process by which an innovation is communicated through certain channels over time among the members of a social system. According to Rogers, innovation diffusion follows a certain trajectory – the S-Curve – where a small group of people in a society adopts the technology first then followed by the majority

until adoption reaches saturation. Rogers asserts that the diffusion of innovations is a social process, as well as a technical matter. The cultural and norm aspects related to stoves adoption and use should not be neglected if diffusion has to take roots (Rogers, 1995).

A literature review on the diffusion of innovations reveals speculations about the slow diffusion process of clean technologies. Factors that may have influence on the dispersion of improved stoves include: size of the stove (Wallmo & Jacobson, 2002) i.e. size could be too small or too large compared to the owner's cooking environment and utensils. Also another factor is the ease in usage (U. Kumar *et al.* 2008, p.18) i.e. how variable or changeable the new technology is (*versatility*). *Technology capability of users* i.e. ability not only to use the technology but also to interact with and (when necessary) change the technology will also affect adoption likelihoods. In Murphy's words, technological capability encompasses: "The information and skills—technical, organizational, and institutional—that allow productive enterprises to utilize information and equipment efficiently" (Murphy, 2001, p.189). Another factor which has a bearing on the diffusion of innovations and sustained adoptions is *information transfer* (Wozniak, 1993) which basically refers to the constant flow of information about the new innovation to users. The economic life time (Kemp & Volpi, 2008, p.15) of the product such as stove i.e. its durability will not only affect existing users but also potential adopters. Last but not least is *R&D* (Smits & Boon, 2008) by implementing organizations (e.g. TaTEDO). This includes interaction with users (feedback – users as source of innovation), surveying and monitoring of stove performance.

Stakeholder participation is central to sustainability and sustainable development. Participation can in itself be a desired end of a project but it can as well be a means to an end. In the former, learning and working on experiences become more important than the project outcomes. In the latter, however, outcomes become the focus of a project (see Figure 4 below). Consumers or users of more sustainable products should not be taken as mere receivers of technology but rather as active participants whose role in innovation is central to sustained adoption and use of new products and services. There is usually a tendency to treat organizations and companies as active and constructive while regarding end-users as passive and reactive. However, one must not forget that knowledge is acquired through the use

of a new product after its adoption, so that users and adopters of improved stoves may prove to be valuable participants in the dissemination of such technology.

Users of newly invented products go through a process of discovery as they use and interact with their new products. Communication between developers and users is therefore crucial if innovation is to diffuse sustainably (Hoffmann, 2007). Users' participation can however be costly and hence needs to be planned before hand. Participation and monitoring costs should be involved in projects' budget. In some cases users may have to be empowered to participate in product development and diffusion. As shown by the figure below, consumer participation is both a reflexive and iterative process (see Figure 4 below) whereby information gathered during outcomes evaluation are fed back to either the problem formulation (loop numbered 3 in Figure 4 below) or to action planning (loop 2) in a refresh-and-restart fashion (Stone, 2006; also in Rogers, 1995). Before planning any intervention action it is also imperative that project consequences are forecasted and action proposals are adequately tested. The forecasted consequences and results from testing should then be fed back to the problem formulation stage and when necessary the problem reformulated accordingly (loop numbered 1 in Figure 4 below).

Sometimes companies and organizations prefer what Bell and Morse refer to as *pseudo-participation* approaches (Bell & Morse, 2004) with a representative included but with no real power. Conventionally and traditionally most projects or at least project owners have their focus on the outputs even before the project begins. Expected outputs are clearly stated out in the project proposals prior to project deployment. This can be a hindrance to most sustainability (or sustainable development) projects as they tend to embrace progressive learning along the course of project implementation. In sustainability science, learning is in itself an output. Simply put: in practice, projects in sustainability science are circular rather than linear and seem to have no 'end' (Bell & Morse, 2005).

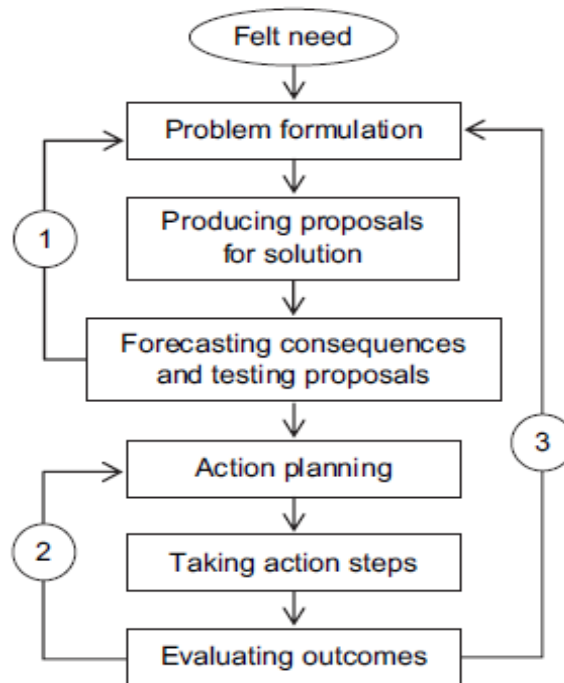

Figure 4: Schein’s “group problem solving” model: the role of stakeholder involvement in technology diffusion
 (Source: adapted from Stone 2006)

Other factors central to adoption and continued use of more sustainable technologies include: *price per unit* (Huh & Kim, 2008) of an item e.g. stove. This refers to the economic purchasing power of the user. It follows that if a stove is too expensive, adoption decisions will be negatively affected. Also, *uncertainty* about the solutions offered by new technology and the future might raise the question: does adoption involve any risks? (Kemp & Volpi 2008, *ibid*). Compatibility with food taste, culture, cooking environment, etc is another area that should be carefully taken into account when dealing with diffusion of products such as improved stoves. Another important factor that may hamper the diffusion of innovations is what Rose-Anderssen *et al*, Hall and Vredenburg refer to as radical innovations (or discontinuous products). Discontinuous products may be received with skepticism by users. Discontinuous innovation may, during its inception stage, not have taken into account (or less rigorously done so) the users' input. The result is a technology-driven (as opposed to demand-driven) development because most users prefer *simple improvement[s]* rather than *radical innovation[s]* (Hall & Vredenburg 2003, p.63; Rose-Anderssen *et al*. 2005, p.63, *ibid*; Barnes *et al*. 1994, p.63, *ibid*).

Sustainable energy transitions, however, seem more complicated in practice than what is portrayed in many theories (Nill & Kemp, 2009).

There is a model that attempts to describe the dynamics of energy transitions – the *energy ladder* model (Arnold et al., 2006, p.599). The central claim of the energy ladder model is that household income has a unidirectional, linear relationship with the household’s type of fuel used as energy source. This theory asserts that there is a clear transition from lower “traditional” to higher “modern” and cleaner fuels as the household income increases. At the lower end of the ladder are dung, residues and wood; and at the higher end are LPG, electricity and renewables. But the results from this study and from Masera’s study in Mexico seem to defy the central tenet of the “energy ladder” (Masera et al., 2000). The ‘truths’ in the energy ladder/pyramid model (see Figure 6 below) seem to hold in some circumstances and time but the model become highly “*pervasive*” in other different settings (Arnold *ibid*). It therefore turns out that the energy ladder approach should not be regarded as universal but rather contextual as there other non-monetary factors that influence the transition from one fuel type to another. Also as Masera puts it; this transition is never a clear-cut because most users seem to prefer a partial switch rather than a complete switch to a new type of fuel (Masera *ibid*). This study and several others show that people in rural areas prefer to keep their (old) traditional stoves even after installing an improved stove (Hiemstra-van der Horst & Hovorka, 2008; Martins, 2005).

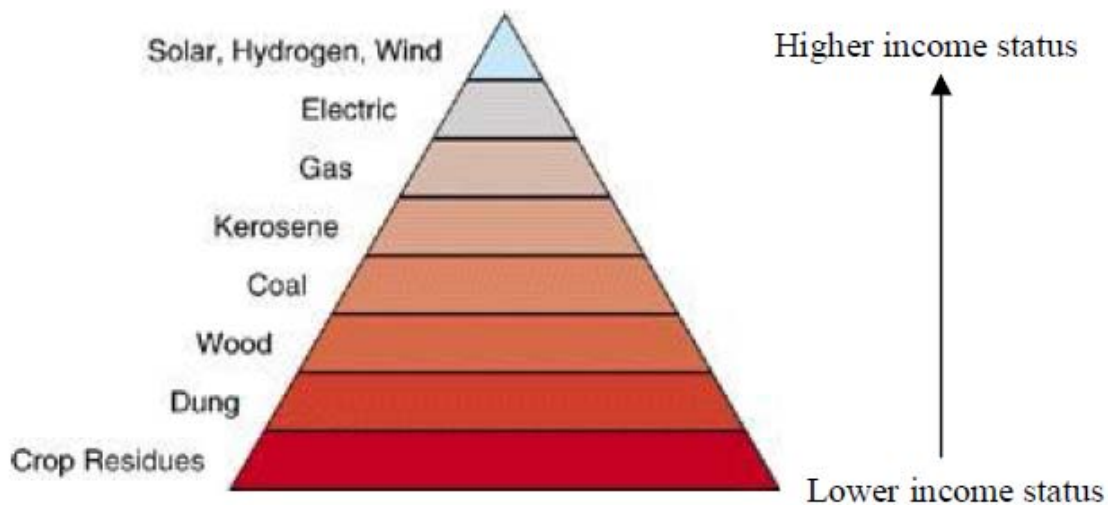

Figure 5: The Energy Ladder or Pyramid⁴

⁴ Accessed, modified and adapted from: <http://www.burningissues.org/car-www/science/Energy-ladder.html> on April 28, 2009

3.2. Methodological considerations

In order to answer my research questions above, I chose to use a qualitative research strategy. My epistemological and ontological considerations are interpretivism and constructionism respectively. With regards to the connection between research and theory, my study will follow an inductive approach. I chose my design to be in the form of a case study, my case in question being post-adoption problems that face stove users (Yin, 2003). Methods used in this study are: semi-structured interviews, unstructured interviews, focus/focused interviews, field observation and literature search. Bryman (2004) defines the three types of interviews used in this study as follows:

- i) Semi-structured: It typically refers to a context in which the interviewer has a series of questions that are in the general form of an *interview schedule* but is able to vary the sequence of questions. The interviewer usually has some latitude to ask further questions in response to what are seen as significant replies.
- ii) Unstructured: Here the interviewer has only a list of topics or issues, often called an interview guide or *aide mémoire*, that are typically covered. The style of questioning is usually informal. Also the phrasing and sequencing of questions will vary from interview to interview.
- iii) Focused interview: This refers to an interview using predominantly open questions to ask interviewees questions about a specific situation or event that is relevant to them and of interest to the researcher (Bryman, 2004).

Apart from conducting interviews my study also benefited from direct field observation and literature search. Field observations were done concurrently with interviews. Observable features in the field such as chimney types, stove design and smoke effects were noted. Documentary search was done prior to and after the field trip. This mixture of methods was used in order to accomplish what Yin and Bryman refer to as *triangulation* – the use of multiple sources of evidence as well as seeking for convergence between the sources (see Yin, 2003, pp.7-13; and Bryman, 2004).

I chose both the interpretivism and constructivism approaches and hence the qualitative strategy because my basic subject matter was not “*data to be quantified, but meaningful relations to be interpreted*” (Kvale, 1996).

As writing down of all the interviews in a notebook may be both cumbersome and time-consuming, a voice recorder was deployed throughout my interviews. I used Olympus™ Digital Voice Recorder VN-5500. After discussing with TaTEDO staff about the use of recording device, I realized that its use could be a distraction to some respondents (also see Bryman, 2004, pp.329-331). My respondents were, however, comfortable and did not appear to be affected by the notion that they were being recorded. The language that was used throughout the interviews was Swahili. Since I am a native Swahili speaker, I did not need a company of an interpreter. A transcript sample of questions and key responses from the interviews are in the Appendices section at the end.

4. Results

As Table 1 (below) indicates, my interview exercise yielded a combined total of 26 interviewees: 13 in Sanya-juu and Magadini villages, and 13 in Kuze-Kibago village, Muheza District. That concluded my interview exercise with stove users, non-users, experts and technicians. It was also an end to the field/direct observation part of my study and the beginning of my post-field documentary enquiry.

4.1. Interview results

People in the *peri-urban* category were characterized by their vicinity to nearby urban areas. People who lived in the area could neither be classified as urban dwellers nor could they be called rural dwellers. Their activities and the kind of lifestyles they live fall in between rural and urban settings. My interviewees in the peri-urban were relatively wealthy families. They had somewhat better housing conditions compared to their rural counterparts. They would also be classified as average-income earners.

Respondents in the *rural* setting, on the other hand, were characterized by their remoteness from the nearby urban areas. Their main economic activity is subsistence farming. They have a lower income when compared with their peri-urban and urban counterparts. Their housing conditions as well as their access to social services are relatively poor.

Table 1: Summary of the interview results

No.	Area	*Area classification	*Category of use	*Type of stove	*Interviewee category	Interviewee's gender
	<i>i. Kilimanjaro region</i>					
1.	Sanya-juu village	Peri-urban	Business	High-cost	User	F
2.	Sanya-juu village	Peri-urban	Business	High-cost	User	F
3.	Sanya-juu village	Peri-urban	Business	High-cost	User	M&F (couple)
4.	Sanya-juu village	Peri-urban	Home	High-cost	User	M
5.	Sanya-juu village	Peri-urban	Home	High-cost	User	F
6.	Sanya-juu village	Peri-urban	Home	High-cost	User	F&M
7.	Sanya-juu village	Peri-urban	Home	High-cost	User	F
8.	Sanya-juu village	Peri-urban	Home	High-cost	<i>Abandoned</i>	M
9.	Sanya-juu village	Peri-urban	Home	High-cost	User	F
10.	Magadini village	Peri-urban	Institutional	High-cost	User/school	F
11.	Magadini village	Peri-urban	Home	High-cost	<i>Abandoned</i>	F
12.	Magadini village	**NA	NA	NA	Technicians	3 M (group)
13.	Moshi town	NA	NA	NA	Expert	M
	<i>ii. Tanga region</i>					
14.	Kuze-Kibago village	Rural	NA	NA	Village guide	M
15.	Kuze-Kibago village	Rural	Home	Low-cost	User	F
16.	Kuze-Kibago village	Rural	Home	Low-cost	User	F
17.	Kuze-Kibago village	Rural	Non-user	NA	Non-user	M
18.	Kuze-Kibago village	Rural	Non-user	NA	Non-user	F
19.	Kuze-Kibago village	Rural	Home	Low-cost	User	M
20.	Kuze-Kibago village	Rural	Business	Low-cost	User	F
21.	Kuze-Kibago village	Rural	Business	Low-cost	User	F
22.	Kuze-Kibago village	NA	NA	NA	Expert	M
23.	Kuze-Kibago village	Rural	NA	NA	Technicians	3 M (group)
24.	Kuze-Kibago village	Rural	Home	Low-cost	User	F
25.	Kuze-Kibago village	Rural	Home	Low-cost	User	F
26.	Kuze-Kibago village	Rural	Home	Low-cost	User	F

*See the clarification below, **NA = Not applicable

Depending on the construction material used and the stove outlook TaTEDO classifies a stove as either institutional or low-cost. Most stoves I have classified as ‘High-cost’ (see below), for instance, would fall under TaTEDO’s institutional category (*interview with TaTEDO staff*). For clarity sake I have come up with a simpler categorization. Institutional stoves in this work refer to stoves used in institutions such as schools and churches.

Improved fuel wood stoves used in Tanzania could also further be divided into two main types: High-cost stoves and low-cost stoves (see Figure 6 below). *High-cost* stoves (Figure 6 B below), as the name implies, are made of more costly materials such as bricks, cement and metal (rings, bars, skirts, grates, and/or pipes). That is why most of these types of stoves are used in urban and peri-urban areas where the population has slightly higher incomes. They are, however, either non-existent or rare in remote rural areas. *Low-cost* improved stoves (Figure 6 A) on the other hand are made of relatively cheaper and locally available materials and easier to construct by users themselves. These are mainly found in remote rural areas. Their major shortcoming, however, is that they do not have a chimney or a smoke hood.

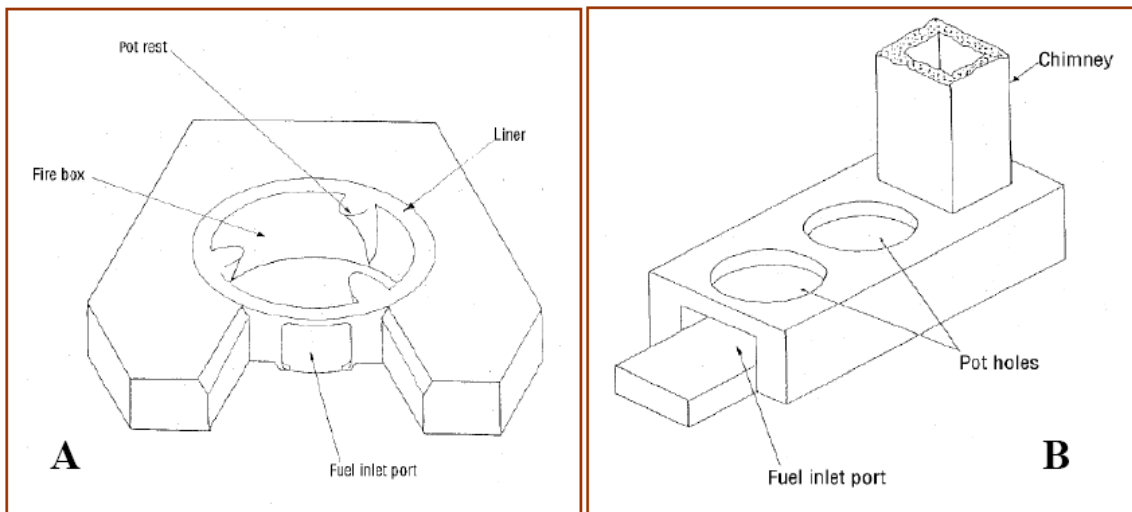

Figure 6: Two types of stoves commonly encountered in the field: A = Low-cost stove found in rural areas; B = High-cost stove found in peri-urban and urban areas
 (Source: Adapted from Karekezi & Turyareeba 1995)

In my study I interviewed about five different types of respondents. Each interviewee category had their own views about the use of improved stoves. The following were the categories of my interviewees. *User* as used in the table above refers to interviewees who own and still use an improved stove. They might be using the stove for home, business or institutional purposes. Also the type of stove they own could be either high- or low-cost one. *Non-users* were people who, for different reasons, do not use improved stoves. Instead they still use the traditional three-stone fires. Their views on the use of both the traditional and improved stoves were important as a way to tentatively weigh and judge the views from users, experts and technicians.

The *abandoned* category of interviewees was the most special one. It includes people who once adopted and used an improved stove but, for some reasons, decided to abandon the improved stove and went back to use traditional three-stone fire.

The *expert* category included promoters of the improved stove technology. They are the designers and disseminators of information about the technology. They do field visits, campaign for the use of improved stoves and train technicians how to replicate stove designs. To put it in one expert's (in interview) words, they are "facilitators" (see more on this in the discussion section). *Technician* refers to the person who acquires the knowledge on how to construct stoves from the experts. They are the ones responsible for construction and actual dissemination of the innovation in the field. Technicians are expected not only to disseminate the stoves but also to generate income out of it (see more in the discussion).

4.2. Field observation

This was concurrently done with interviews. As I interviewed my respondents I was, at the same time, getting note of all the observable features. Users of improved stoves who, for example, complained about the problem of smoke could show me how stained their kitchen walls were. Things such as the presence of both the traditional and improved stove in a single kitchen could also be observed.

4.3. Documentary search

This was done before fieldwork started, during field work and after field work. Apart from the university libraries and online sources, some other documentary sources were obtained from the TaTEDO library. Access to the organization's library was helpful as it gave me more in-depth information about stoves, their dissemination, adoption and use in Tanzania. My use of their library proved to be useful because I had access to their records containing detailed information about the situation of improved stoves in the country.

5. Findings and discussion

5.1. Stove adoption – the system drivers

To guide the discussion, I have made a conceptual diagram (Figure 7 below) that depicts the factors that I found to be important in influencing stoves adoption and use in my study. These factors include, but are not limited to: perceived benefits, available assets (cash, time plus other resources), biomass

availability and availability of information (awareness). Other factors include the kitchen type and the influence existing users exert on potential users.

Organizations that facilitate the diffusion of improved stoves act as the source of information and through sensitization campaigns they create awareness about the benefits of using the improved stoves. Potential users in turn have their own perception of improved stoves. After weighing the benefits of an improved stove against those of a traditional one, the potential user can make a decision to adopt the stove or not. The link between information and adoption is a weak one (shown by the dotted line in the diagram) – not many users will decide to adopt the stove without going through the benefit weighing step first. Some users I found in the field, however, can be a typical example of the ones represented by the dotted line. These are users who adopted the stoves for demonstration purposes. Their stoves were used as showcases for potential users in the community.

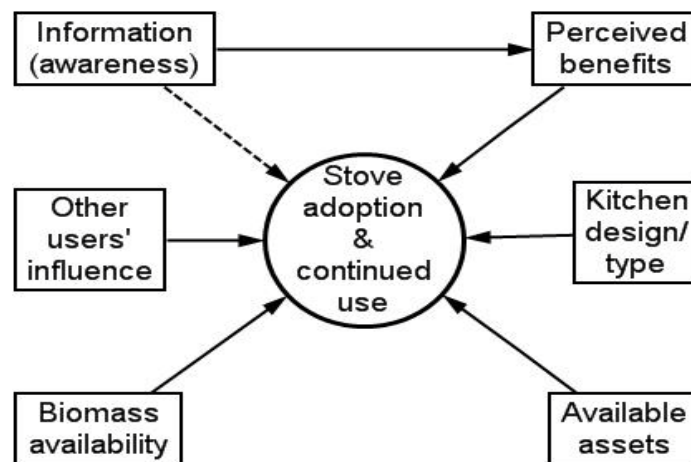

Figure 7: Factors affecting the stove adoption and use system
(Source: Rwiza, 2009)

The available assets factor does not necessarily have to be in monetary terms. Some of my respondents revealed that all they had to contribute was their time, manpower and construction material. In the event that the user has neither the time to provide the needed manpower nor the construction material required, he/she will subsequently have to pay for the stove in monetary terms. For the high-cost type the cost to construct the stove was between TAS 75000 to 100000 (approx. US\$ 90). For the low-cost stove the cost was less than TAS 10000 (approx. US\$ 10). For some adopters their adoption was a result of observing and being influenced by existing users. Other factors in the diagram above are explained in more details below.

There were three main categories of stove users I investigated on: home user, business users and institutional users. Different ways through which users were persuaded to adopt improved stoves were pointed out. Some users saw the technology at work places (e.g. schools and restaurants) and they decided to adopt the technology at home. There are users who said that they were visited by experts and/or technicians who told them about improved stoves before they made the adoption decision. Other users claimed that they adopted improved stoves after they had attended training sessions where they were taught the benefits of using improved stoves. While others said that they made the decision to adopt improved stoves after they saw awareness creation campaigns. Most users, however, made a decision to adopt improved stoves after seeing the stoves in their neighbours and friend's homes.

When asked about how they got to know about improved stoves, respondents in Sanya-juu and Magadini villages mentioned the Angaza Women Centre (AWC) as their source of information. Interviewees told me how they attended workshops, training sessions and seminars to learn about sustainable energy for rural livelihoods at the centre. I also did my research on AWC and informally interviewed the women who run the centre. This is a group of women affiliated to the Evangelical Lutheran Church of Tanzania (ELCT). Through collaboration with various stakeholders; they organize sensitization campaign for rural people who come to their centre to learn about sustainable rural energy and livelihoods practices. Their funding comes from the hostel they run, the church and partners. They have been successful in 'spreading the word' about sustainable rural energy practices. TaTEDO has been working with AWC to reach rural communities with the message of improved stoves. Intermediate groups such as AWC could act as points of entry to communities in disseminating innovations.

5.2. User's perception of the benefits

5.2.1. Wood-saving

Unlike what is portrayed in the literature about the benefits of improved stoves, users I interviewed had a slightly different perception of the stoves' benefits. In the literature the account of how improved stoves could play a role in reducing deforestation is clearly pointed out. The reasoning behind this claim is as follows: since improved stoves are more efficient, people who adopt the stoves can reduce the amount of firewood collected for their daily needs, hence lifting the burden on forest wood

products. This is the classic environmental conservation argument for improved stoves. While respondents pointed out the wood-saving feature of improved stoves, they hardly linked this to deforestation. Actually improved stove users did not mention the environment at all when they were asked about what they consider as the benefits.

I had a question where I asked stove users to rank the improved stove in terms of the number of firewood pieces used as compared to traditional three-stone stove. I asked them if, say, they were using 10 pieces of firewood per day with the traditional stove, how many pieces out of those 10 they thought the improved stove used. Interestingly the answer was 3 to 5 pieces a day. For other users I asked the same question in a different way. I asked them if, say, a bunch of firewood lasted for 3 days with traditional three-stone stove, then how many days they thought the same bunch of firewood would last using the improved stove. The answer to this was 5 to 7 days per bunch of firewood. Although it is not statistically proven, and my study was not a quantitative one, users perceive the improved stoves to be 50% more efficient than the traditional stove.

5.2.2. Economy rather than the environment

Users' views of the benefits rendered by improved stoves were mainly economical. They pointed out that by using improved stoves they did not use as much firewood as they used to when they were using traditional stoves. Those who used improved stoves for business purposes linked wood-saving to financial savings. They pointed out that they did not use as much money to buy firewood as they used to do.

5.2.3. Easier and faster cooking

Another claim, probably the most frequently encountered, was that cooking was easier and quicker/faster using improved stoves than it was when one used a traditional stove. The respondents, mainly women, pointed out that when using improved stoves they were saving time. Time saved could be used in other activities.

5.2.4. Heat conservation

Heat conservation was also pointed out as a benefit the improved stove has over the traditional one. Respondents claimed that improved stoves kept food warm for a longer period of time. In areas, like Kilimanjaro, where the weather is colder users claimed that they would leave water on the improved

stove after they have cooked the evening meal and find the water still warm when they wake up in the morning. Others said that heat was not wasted by being blown by wind. They claimed that when they were using traditional three-stone stoves, wind would blow the fire sideways and lead to heat losses.

5.3. Technological capabilities, technical and institutional aspects

For the diffusion of innovations to be successful adopters need to develop the required technical and technological capabilities. A state has to be reached whereby the user feels at ease to manoeuvre, control and own the technology. Most peri-urban respondents did not feel free to modify or attempt to do repairs on the improved stoves, no matter how minor those modification and repairs seemed. They either waited or called for the technician whenever they encountered a problem in using the technology.

Some respondents said they could not clean the stove's chimney when it got clogged – although they were taught how to. Users in the rural setting however did repairs to their stoves when damage occurred. The reason for this disparity may be that most urban and peri-urban stoves are not as simple as those found in rural areas. The urban 'high-cost' stove is constructed using materials such as cement, bricks and metal and may not be easy to manoeuvre. Unless stove experts come up with simpler design it may prove difficult for users to develop the required technological capabilities needed for diffusion of innovations to flourish.

5.3.1. Not improvement but alternative

When I asked one of my respondents what his views on improved stoves programs were, his response was: *“Conservation authorities have now restricted access to forestry resources including the collection of firewood. So maybe designing stoves that use firewood is no longer a good idea.”* He continued to point out that it would be even a better idea to design stoves that use waste. He said their village was near to sawmill factories and that there was a great deal of potential to use sawdust for cooking. This is a challenge for improved stove designers. Perhaps reconnaissance surveys should be done to identify the readily available and more sustainable resources before certain designs are disseminated. Stove designs need not be uniform across the country; designs should align with the locally available resources.

5.3.2. Improved but not clean?

I asked a woman who was using the improved stove at a restaurant she owned what would her reason be if she wanted to abandon the improved stove. Her response was: *“I don’t know but maybe if my status (living standard) changes and I have more money I may get tired of ashes and decide to use an electric stove instead.”* Her message was clear – although she praised the improved stove, she did not see it as a clean technology. She was not satisfied with mere improvement; she saw a possibility of upgrading.

5.3.3. Improved but not smokeless

Stove adopters, it seems, believe or have been made to believe that improved stoves are smokeless while they are actually not. From my observations and interviewing households where they used improved stoves in enclosure, exorbitant exudation of smoke and its immediate effects were obvious. Unfortunately these users are made to believe that they have only themselves to blame – for not cleaning up the chimneys. Most technicians cite chimney blockage as the main reason responsible for smoky stoves. What I realized though was that, the stoves themselves were not designed to be used in a totally enclosed space. I tried to give a piece of advice to one of my respondents that she should open all the windows during cooking, her response was: *“When we start cooking at night we have to make sure all the doors and windows are open but this is also a problem because when you open windows and doors, mosquitoes start getting in to the house.”*

Although they did not point out the link between indoor air pollution and maternal/child health, my respondents in the semi-urban area reported failure to get rid of smoke as the major downside of improved stoves. Data from my interviews and observation indicate that five factors contribute to improved stoves’ smokiness: chimney cleanliness, chimney type, poor kitchen ventilation, moisture content of firewood used, and pan/pot size.

Technicians and experts pointed out the accumulation of soot in chimneys as the main reason why users might experience the smoke problem. They assert that users should clean their chimneys at least twice a week. But as we have already seen above, taking into account the fact that main users of stoves are women and small children, this might not be an easy task.

Technicians also pointed out the type of chimney used as a factor that may influence chimney performance and hence smoke removal efficiency. In the households that I visited, two types of chimney were encountered: metal pipes and brick-made (see Figure 8 below). Technicians asserted that metal-based chimneys were more problematic than brick-made ones. The metal ones had smaller diameters as compared to the brick ones. It also seemed that the accumulation process of the products of incomplete combustion was faster in the metal pipes than in brick-made chimneys. Technicians admitted to receiving more smoke complaints from users who used metal chimneys than from those who used brick chimneys.

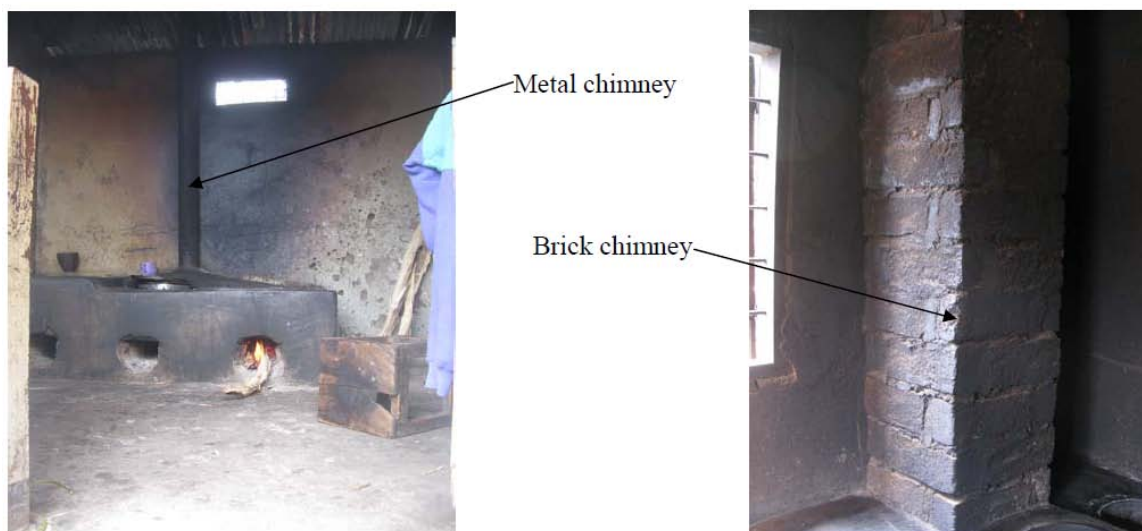

Figure 8: The two types of chimney: metal and brick in Sanya-juu village
(Source: *Rwiza, 2009*)

Kitchen ventilation was another factor pointed out that seemed to affect smoke removal. Allowing sufficient incoming air flow into the kitchen facilitates both the combustion process and the removal of smoke from the stove's fire chamber (see also in Nyström, 1994; and Report3, 1993). Users who had their stoves in an almost completely enclosed environment complained more about the smoke problem than those whose kitchens were sufficiently ventilated.

Wood moisture content also affects the amount of smoke from improved stoves. Dry firewood burns more easily than wet firewood. Because of this 'smooth' combustion process, users who use well dried firewood will experience less products of incomplete combustion than those who use relatively wet pieces of firewood.

Using a pan whose diameter is less than that of the pot holder will allow smoke to escape through unfilled gaps. Stove technicians recommend stove users to use pans whose sizes match the size of pot holders. This, again, can be a difficult task. A technician in Magadini village encountered a user who remarkably asked: “*What if I want to make porridge for my baby? Do I still have to use the same family-size pan?*”

5.3.4. Housing type versus stove used

There was a widespread notion among my respondent that one had to have a particular type of kitchen or housing to adopt an improved stove. Some non-users said, “*I am waiting until I construct a better kitchen*” when I asked them why they did not have an improved stove. This thinking may have arisen because stove campaigners had approached people with certain housing types in a bid to attract other people to follow suit. Rogers (1995) explains the problem of an ‘outsider’ in the diffusion of innovations. He asserts that innovation propagators have to be careful because people who are deemed influential may sometimes be viewed as outsiders in certain communities. Local people might reject a technology simply because early adopters were of an ‘outsider’ type. Most people with good housing in rural areas are usually immigrants – extension officers, nurses, teachers, etc. There is usually a temptation to exert the adoption campaigning efforts to the ‘high status’ group of people thinking that they are an example that can be followed by the rest of the society. Unfortunately it doesn’t always work that way. Because indeed “*the diffusion of innovations is a social process, as well as a technical matter*” (see Rogers, 1995, pp.1-5).

5.4. Parallel use of both – reasons

If we thought that introducing improved stoves would help to reduce the burden on forest resources and reduce indoor air pollution, we probably need to pause and think again. It is not uncommon to find people in rural and in some urban households using both the improved stove and the traditional three-stone fires together. Below are some reasons why users may decide to keep the traditional stove alongside the improved one.

Some users may feel insecure in putting their absolute trust in a new and unfamiliar technology. They keep their old stoves as backups. Some unforeseen fault or damage may occur that may render the new

technology unsuitable for use. So they keep their old stoves to safeguard against risk and uncertain future events.

At a school in Magadini village, for example, they used both the improved and the traditional technology. Their reason was that the improved stove had pot holders of specific diameter. They could not use the improved stove when they wanted to use a pot whose diameter was larger than the holder's. The improved stove at this school was installed when the number of pupils was less than the current number. To solve the problem of holder-pot incompatibility they re-deployed the traditional three-stone fires. Therefore incompatibility between a stove and utensils may lead some users to keep their traditional stove as it does not have this problem.

In remote rural areas three-stone fires are used for other purposes besides cooking. My interviews with rural peasant households revealed that three-stone fires are used for space heating, crop drying and preservation, and lighting. Users in Kuze-Kibago, for example, claimed that improved stoves confine heat rather than allowing it to spread out. When I interviewed technicians in Magadini village about any (negative) perceptions local people had on improved stoves, one technician said: "*Wanadai hawawezi kuota moto kwenye jiko-sanifu*" Swahili meaning "*People claim that an improved stove cannot serve as a fireplace.*"

In Kuze-Kibago village, a household that used both the improved and traditional stove had a bunch of corn/maize hanging over the traditional stove. Heat from the traditional stove was used to dry corn (see Figure 9 below). Rural small-holder farmers also believe that smoke from three-stone stoves can act as insect repellent and hence protect crops from damage (also see a critique by Gill, 1987, p.138).

Another reason why some respondents used both the traditional and improved stoves was because of what I would call the *inversatility* (inflexibility) or *immaneuverability* nature of improved stoves. One woman in Kuze-Kibago village said she only had one pot holder on her improved stove and sometimes she had two pots to cook. So to cook two pots of food simultaneously she had to make fire on the traditional stove as well. Others, however, regarded the multi-pot function of improved stoves as a disadvantage and they reverted to their traditional stove when they had only one pot to cook. To some users, therefore, improved stoves were viewed as rigid and non-versatile. Another aspect of

inversatility is the one pointed out by Gill; when the adopter needs to use other types of biomass but her stove is designed to use firewood. Rural poor households use a range of biomass fuels on their traditional three-stone stoves – crop residues, animal dung. Adopters of improved stoves may find it inconvenient to use these other biomass types on a stove that was designed to use a particular type of biomass – wood (Also see Gill, 1987, p.138).

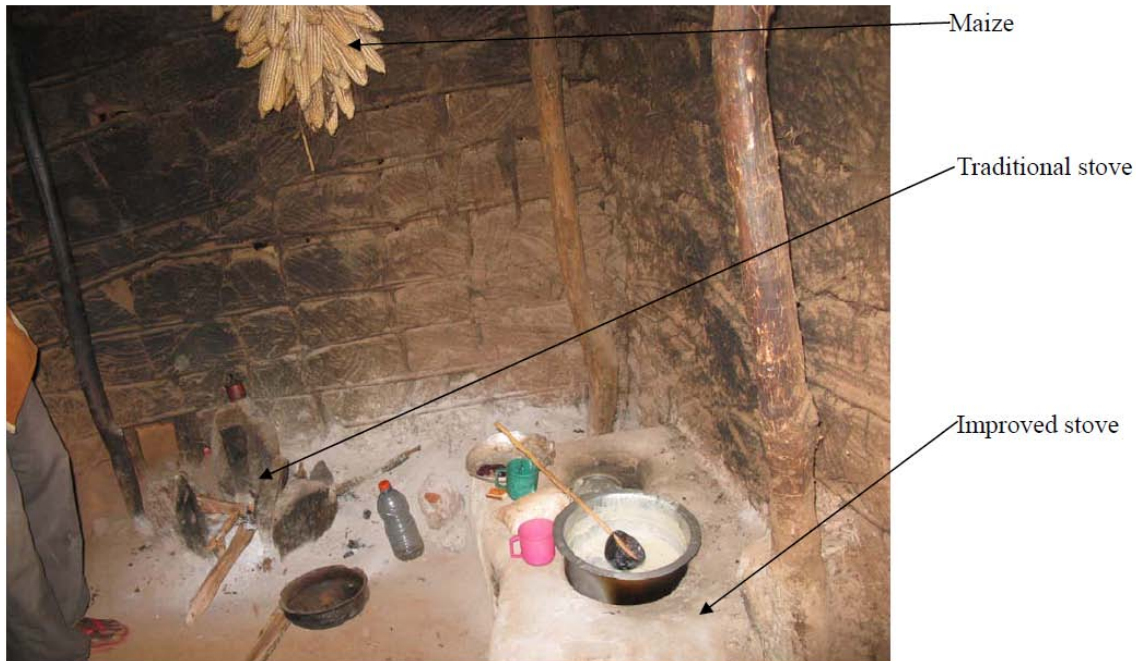

Figure 9: Maize hanging over the traditional stove in Kuze-Kibago village
(Source: Rwiza, 2009)

Lastly on dual use of stoves, in Sanya-juu village, I interviewed a household that had two kitchens with a different type of stove in each. I wanted to know why they had two kitchens instead of one. The reason I was given was that it was a taboo for a daughter to share the same kitchen with her mother-in-law. So while the daughter used the improved stove in her kitchen, her mother-in-law used the traditional three-stone stove in the other kitchen. Karekezi and Turyareeba referred to some of the above discussed issues as “*wrong assumptions at the design stage*” (see Karekezi & Turyareeba, 1995, p.13). These issues, therefore, need to be taken into careful consideration right from the design stage of any improved stove program.

5.5. The gender side of improved stoves

One of the questions that I asked my respondents was about the cost of constructing an improved stove. The majority of my respondents, most of them being women, did not know how much it cost to construct a stove. Women told me that it was their husbands who paid for and supervised the construction work. One woman in Kuze-Kibago village told me that she had gone to the field and found the stove constructed in her kitchen upon her return. That raised the question about women's participation in the adoption of stoves. It is a known fact that most men in the developing countries, and especially in rural poor communities, do not (or rarely do?) cook. It is also known that in most developing countries, cooking and taking care of children is almost done entirely by women. How then can a man, who does not cook, be trusted to decide where to locate the stove and determine how the stove should look like? Any improved stove dissemination endeavours that do not prioritize women are prone to failure (Barnes *et al.*, 1994). Studies indicate that women have a central stake when it comes to the adoption and use of improved stoves. But as Karekezi says it; issues that pertain to gender-energy interrelationship in Africa south of Sahara “*are yet to be addressed substantially in macro-level policies*” (Karekezi & Kithyoma, 2002, p.1074). Unfortunately whatever happens at the macro-level policy-making will inevitably affect decisions made at the lower micro-levels.

5.6. Conceptualizing abandonment: The Bridge to Abandonment

When we were discussing with technicians about the abandonment of the improved stoves by some users, I conceptualized it as a process rather than an instant occurrence. For me it sounded more like a bridge, a wood bridge, with horizontal beams and supporting suspenders (see the diagram below, Figure 10). The horizontal beams represent the steps the user will take to reach the decision to abandon or keep the improved stove. Suspenders on the other hand are those steps taken by the user in her attempt to involve other stakeholders before she arrives at the decision to abandon or keep the improved stove.

Steps to abandoning an improved stove begin with discovering a problem or fault of the stove. This can be anything – smoke, a crack, firewood does not catch fire, cooking inconvenience etc. After the user discovers a problem she can either decide to report it or rectify it on her own. The reason why she may report the problem is to get more support to solve the problem. If she fails to rectify the problem, she will be curious and would want to know if her neighbors face similar problems. Subsequently, her

neighbors' stove performance will have a direct impact on her perception of the improved stove. This will be followed by the discouragement step. Finally if the problem is not solved, she will abandon the stove but if the problem is solved, she will keep the stove.

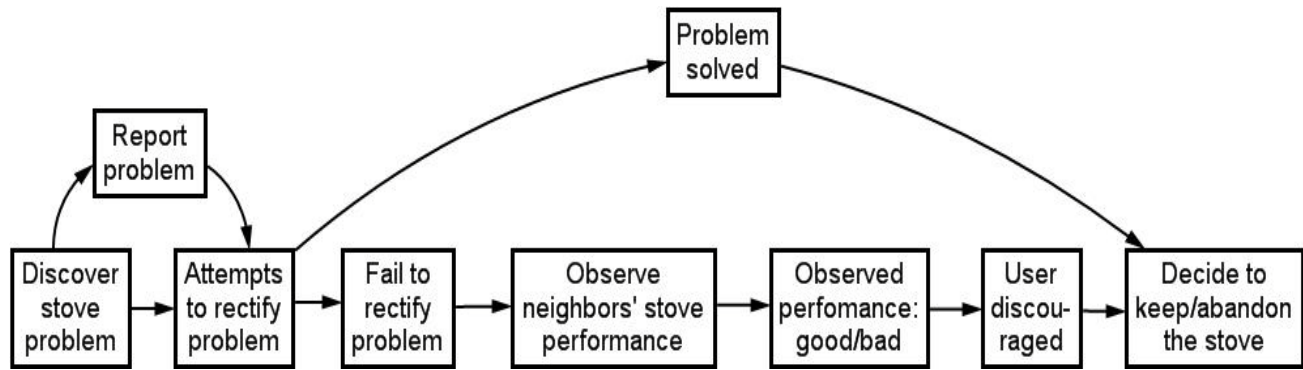

Figure 10: The bridge to improved stove abandonment
(Source: Rwiza, 2009)

6. Conclusion and recommendations

The strong correlation between access to reliable energy and sustainable development cannot be overemphasized (United Nations, 2009). The more access people have to sustainable energy options, the more probable it is for them to move up the development ladder. In the context of developing countries, to realize socioeconomic development of rural communities, the scale of energy projects is important. In the past, governments and donors have focused on huge mega-watt hydropower projects and overlooked the potential of small-sale projects such as improved stoves which could have direct positive impacts on people's livelihoods (Kanagawa & Nakata, 2007; Odhiambo, 2009, p.617; Gururaja, 2003).

Improved stoves programs in Tanzania, like in many other developing sub-Saharan Africa countries, have not been given sufficient priority by policy makers. Efforts to diffuse this technology are fragmented and hence the proportion of the population reached is still very small. There is still a great need of awareness creation in the areas that have not been reached. As Jaffe *et al* suggest; lack of information can have a negative impact on the diffusion process of environmental goods (Jaffe *et al*. 1994, p.98). Implementing organizations, the government and donors should also emphasize on reconnaissance surveys (research) prior to deployment of any stove projects. There are areas in the country with plenty of forest resources, where firewood is either relatively cheap or free of charge.

Communities in areas such as this require a different approach. Mere verbal encouragement or information on the ability of improved stove to save firewood may prove to be futile (see more on this in Karekezi & Kithyoma, 2002, pp.1074-1075).

Apart from recognizing what the needs of people are, reconnaissance will also give the implementing organizations (e.g. TaTEDO) an idea of what biomass resources are locally available and hence come up with stove designs that suit local situations. If, for example, chaff or debris is the readily available and easily accessible form of biomass, a stove that uses waste biomass would be more suitable than a wood-using one (Ezzati, 2009; Wamukonya, 1995). Thorough contextual research prior to project deployment will also give implementing bodies (NGOs, CBOs, or government) a thorough understanding of the local people's culture. This is important because cultural aspects seem to have a bearing on what people will choose to adopt (Murphy 2001, p.181 also in Karekezi 2002, *ibid*).

This study also reveals that many stove users were ignorant of the health benefits of using improved stoves. A community sensitizing approach that carries a message about the health benefits of improved stoves could make a difference on people's acceptance, perception and likelihood to adopt and use the technology. The recipient of the message proves a vital factor as to whether the program succeeds, much more so than the message itself – women should be the primary targeted audience. Scientific evidence and studies show a direct correlation between indoor air pollution and several health ailments. The use of inefficient traditional biomass stoves has been pointed out as the major contributor of indoor air pollutants in developing countries. Also studies show that it is women and children who suffer the most (Bailis et al., 2005; Ezzati & Kammen, 2001; Gordon et al., 2007; Edelstein et al., 2008; Bruce et al., 2000; Mbinda & Kammen, 2000). Women would therefore be more concerned about their own and their children's health than about saving firewood.

Promoters of improved stoves should also recruit the help of other groups such as community-based organizations (CBOs), churches and even (for the case of TaTEDO) other NGOs who operate in the same local area. Building a network of partnership within a locale e.g. a district or region would prove to be more fruitful than embarking on a unilateral endeavor. TaTEDO has already started on this. In Sanya-juu and Magadini villages for example I found out that TaTEDO was working with the Angaza

Women Center (AWC), a church-affiliated association. Such collaborative efforts are required to reinforce the message successfully.

In Kuze-Kibago village and Muheza the Eastern Arc Mountains Endowment Fund (EAMCEF), this study found, is currently working with the Muheza District Council (MDC) on several environmental and livelihoods projects with the dissemination of improved stoves as one among the projects. I also found that the Tanzania Forest Conservation Group (TFCG) had been facilitating the dissemination of improved stoves in Kuze-Kibago and other villages in Muheza district.

Forming a network of stakeholders with the common interest in improved stoves to work together could help avoid duplication of efforts and resources. There is another special group of stakeholders that I noticed that could be very useful in stoves propagation programs – people who have imitated, modified and in a way improved (more) the technology. Although they were not many but in all the three villages there were people who, by imitating, constructed improved stoves in their own style and design. These creative and innovative individuals could provide the much needed inputs in designing improved stoves which suit local environments.

One of the major hindrances related to the adoption and use improved stoves that I identified was the stoves' technical problems. It seemed like people adopt improved stoves with very high expectations only to find out that stoves cannot meet all their pre-conceived expectations. It also could be that artisans and technicians who construct the stoves deliver an improper message to their potential stove users. As indicated in the discussion section above; there were many problematic technical aspects of improved stoves that I observed and heard from my respondents. Most of these problems could however be avoided if thorough participation and communication with stakeholders were sought prior to and during project deployment. Also as shown in Schein's group problem solving model, evaluation of projects outcome and feeding the findings from evaluation back to 'action planning' and 'problem' formulation steps could be useful (Stone, 2006). If for example the smoke problems were clearly pointed out before people made decision to install improved stoves, many users may have decided to locate their stoves in a ventilated environment. The message about stoves' limitations has either not been pitched or misunderstood. Therefore my recommendation with regard to stove's technical limitations would be threefold: 1) to sufficiently involve stakeholders right from projects inception to

their implementation; 2) deliver a proper and adequate message to prospective and existing stove users and 3) through evaluation of the projects, use the information gathered from users to act accordingly. One aspect of technology diffusion which has been underutilized by stove promoters is the importance of users as a source of information and innovation (Stone, 2006). As Gamser reveals; tapping from this knowledge base could facilitate the propagation and adoption of improved stoves to a greater extent (Gamser, 1988). Consumer integration (Hoffmann, 2007) and stakeholder involvement (Bell & Morse, 2004) is therefore central to sustained and successful diffusion of innovations.

In conclusion and from what I learned and presented in this work, the following observations should contribute to more successful dissemination of improved stoves:

- There are more uses (benefits) of traditional hearths than simply cooking
- Traditional stove users may use other forms of biomass besides firewood
- Users' households use pots/pans of different sizes at different occasions
- There are many cultural aspects related to stoves use
- Other aspects such as ease (fast or quick) in cooking are sometimes regarded by users as more important than fuel saving (see the Appendices). Last but not least:
- End-users can play a more important role in the diffusion of innovations than being passive and reactive recipients.

There is still a lot to be done and learned with regards to the dynamics of improved stoves adoption and use in developing countries and further research in this area is still highly needed.

7. Bibliography

- Arnold, J.E.M., Köhlin, G. & Persson, R. (2006) Woodfuels, livelihoods, and policy interventions: changing perspectives. *World Development*, 34 (3), pp.596-611.
- Bailis, R., Ezzati, M. & Kammen, D.M. (2005) *Mortality and greenhouse gas impacts of biomass and petroleum energy futures in Africa*. American Association for the Advancement of Science.
- Barnes, D.F., Openshaw, K., Smith, K.R. & van der Plas, R. (1993) The design and diffusion of improved cooking stoves. *The World Bank Research Observer*, 8 (2), pp.119-141.
- Barnes, D.F., Openshaw, K., Smith, K.R. & van der Plas, R. (1994) What makes people cook with improved biomass stoves. *A comparative international review of stove programs*. Washington, DC: *The World Bank*.
- Bell, S. & Morse, S. (2005) Delivering sustainability therapy in sustainable development projects. *Journal of Environmental Management*, 75 (1), pp.37-51.
- Bell, S. & Morse, S. (2004) Experiences with sustainability indicators and stakeholder participation: a case study relating to a 'Blue Plan' project in Malta. *Sustainable Development*, 12 (1), pp.1-14.
- Berrueta, V.M., Edwards, R.D. & Maser, O.R. (2008) Energy performance of wood-burning cookstoves in Michoacan, Mexico. *Renewable Energy*, 33 (5), pp.859-870.
- Biol, F. (2007) Energy economics: a place for energy poverty in the agenda? *ENERGY JOURNAL-CAMBRIDGE MA THEN CLEVELAND OH-*, 28 (3), p.1.
- Bruce, N., Perez-Padilla, R. & Albalak, R. (2000) Indoor air pollution in developing countries: a major environmental and public health challenge. *Bulletin of the World Health Organization*, 78, pp.1078-1092.
- Bryman, A. (2004) *Social Research Methods*. Oxford University Press.
- Crutzen, P.J. & Andreae, M.O. (1990) Biomass burning in the tropics: Impact on atmospheric chemistry and biogeochemical cycles. *Science*, 250 (4988), pp.1669-1678.
- Edelstein, M., Pitchforth, E., Asres, G., Silverman, M. & Kulkarni, N. (2008) Awareness of health effects of cooking smoke among women in the Gondar Region of Ethiopia: a pilot survey. *BMC International Health and Human Rights*, 8 (1), p.10.

- Ezzati, M. (2009) Indoor Air Pollution and Africa Death Rates [Internet]. Available from: <http://www.rff.org/Publications/WPC/Pages/09_15_08%20Indoor%20Air%20Pollution%20and%20Africa%20Death%20Rates.aspx> [Accessed 23 May 2009].
- Ezzati, M. & Kammen, D.M. (2001) Quantifying the effects of exposure to indoor air pollution from biomass combustion on acute respiratory infections in developing countries. *Environmental Health Perspectives*, 109 (5), pp.481-488.
- Gamser, M.S. (1988) Innovation, technical assistance, and development: The importance of technology users. *World Development*, 16 (6), pp.711-721.
- Gill, J. (1987) Improved stoves in developing countries: a critique. *Energy policy*, 15 (2), pp.135-143.
- Gordon, J.K., Emmel, N.D., Manaseki, S. & Chambers, J. (2007) Perceptions of the health effects of stoves in Mongolia. *Journal of health organization and management*, 21 (6), pp.580-587.
- Gururaja, J. (2003) Energy for sustainable development: Review of national and international energy policies. In: *Natural Resources Forum*. Blackwell Publishing Ltd, pp.53-67.
- Hall, J. & Vredenburg, H. (2003) The challenges of innovating for sustainable development. *MIT Sloan Management Review*, 45 (1), pp.61-68.
- Hiemstra-van der Horst, G. & Hovorka, A.J. (2008) Reassessing the “energy ladder”: Household energy use in Maun, Botswana. *Energy Policy*, 36 (9), pp.3333-3344.
- Hoffmann, E. (2007) Consumer integration in sustainable product development. *Business Strategy and the Environment*, 16 (5), pp.322-338.
- Huh, Y.E. & Kim, S.H. (2008) Do early adopters upgrade early? Role of post-adoption behavior in the purchase of next-generation products. *Journal of Business Research*, 61 (1), pp.40-46.
- Jaffe, A.B. & Stavins, R.N. (1994) The energy paradox and the diffusion of conservation technology. *Resource and Energy Economics*, 16 (2), pp.91-122.
- Johnson, M., Edwards, R., Alatorre Frenk, C. & Masera, O. (2008) In-field greenhouse gas emissions from cookstoves in rural Mexican households. *Atmospheric Environment*, 42 (6), pp.1206-1222.
- Kanagawa, M. & Nakata, T. (2007) Analysis of the energy access improvement and its socio-economic impacts in rural areas of developing countries. *Ecological Economics*, 62 (2), pp.319-329.
- Karekezi, S. & Kithyoma, W. (2002) Renewable energy strategies for rural Africa: is a PV-led renewable energy strategy the right approach for providing modern energy to the rural poor of sub-Saharan Africa? *Energy Policy*, 30 (11-12), pp.1071-1086.

- Karekezi, S. & Majoro, L. (2002) Improving modern energy services for Africa's urban poor. *Energy Policy*, 30 (11-12), pp.1015-1028.
- Karekezi, S. & Turyareeba, P. (1995) Woodstove dissemination in Eastern Africa--a review. *Energy for Sustainable Development*, 1 (6), pp.12-19.
- Kemp, R., Loorbach, D. & Rotmans, J. (2006) Transition management as a model for managing processes of co-evolution towards sustainable development. *Perspectives on Radical Changes to Sustainable Consumption and Production (SCP)*, 20, pp.387-405.
- Kemp, R. & Volpi, M. (2008) The diffusion of clean technologies: a review with suggestions for future diffusion analysis. *Journal of Cleaner Production*, 16 (1S1), pp.14-21.
- Kumar, U., Kumar, V. & de Grosbois, D. (2008) Development of technological capability by Cuban hospitality organizations. *International Journal of Hospitality Management*, 27 (1), pp.12-22.
- Kvale, S. (1996) *Interviews: An Introduction to Qualitative Research Interviewing*. Thousand Oaks, SAGE.
- Martins, J. (2005) The impact of the use of energy sources on the quality of life of poor communities. *Social Indicators Research*, 72 (3), pp.373-402.
- Masera, O.R., Saatkamp, B.D. & Kammen, D.M. (2000) From linear fuel switching to multiple cooking strategies: a critique and alternative to the energy ladder model. *World development*, 28 (12), pp.2083-2103.
- Mbinda, B. & Kammen, D. (2000) Comparison of emissions and residential exposure from traditional and improved cookstoves in Kenya. *Environ. Sci. Technol*, 34, pp.578-583.
- MEWM (1992) The Energy Policy of Tanzania. Available from:
<<http://www.tzonline.org/pdf/theenergypolicyoftanzania.pdf>> [Accessed 5 April 2009].
- Murphy, J.T. (2001) Making the energy transition in rural East Africa: Is leapfrogging an alternative? *Technological Forecasting and Social Change*, 68 (2), pp.173-194.
- NBS (2005) Tanzania Demographic and Health Survey 2004–2005. *Dar es Salaam and Calverton, MD: National Bureau of Statistics and ORC Macro*.
- Nill, J. & Kemp, R. (2009) Evolutionary approaches for sustainable innovation policies: From niche to paradigm? *Research Policy*, 38 (4), pp.668-680.
- NSGRP (2005) The National Strategy for Growth and Reduction of Poverty. Available from:
<<http://www.tanzania.go.tz/pdf/nsgrptext.pdf>> [Accessed 31 March 2009].
- Nyström, M. (1994) *FOCUS Kitchen Design: A study of housing in Hanoi*. Lund, Sweden.

- Odhiambo, N.M. (2009) Energy consumption and economic growth nexus in Tanzania: An ARDL bounds testing approach. *Energy Policy*, 37 (2), pp.617-622.
- PCIA (2009) About PCIA | The Partnership For Clean Indoor Air [Internet]. Available from: <<http://www.pciaonline.org/node/2>> [Accessed 23 May 2009].
- Rehfuess, E. (2007) United Nations Commission on Sustainable Development—a missed opportunity for action on indoor air pollution? *Energy for Sustainable Development*, 11 (2), pp.82-83.
- Report3 (1993) *Kitchens, Living Environment and Household Energy in Vietnam*. Lund, Sweden, BTJ Tryck AB.
- Rogers, E.M. (1995) *Diffusion of innovations*. 4th ed. New York, Free Press.
- Rose-Anderssen, C., Allen, P.M., Tsinopoulos, C. & McCarthy, I. (2005) Innovation in manufacturing as an evolutionary complex system. *Technovation*, 25 (10), pp.1093-1105.
- Rosenthal, E. (2009) Third-World Stove Soot Is Target in Climate Fight. *The New York Times*. Available from: <http://www.nytimes.com/2009/04/16/science/earth/16degrees.html?_r=3&ref=global-home> [Accessed 15 April 2009].
- Sagar, A.D. (2005) Alleviating energy poverty for the world's poor. *Energy Policy*, 33 (11), pp.1367-1372.
- Smith, K.R., Khalil, M.A.K., Rasmussen, R.A., Thorneloe, S.A., Manegdeg, F. & Apte, M. (1993) Greenhouse gases from biomass and fossil fuel stoves in developing countries: A Manila pilot study. *Chemosphere*, 26 (1), pp.479-505.
- Smits, R. & Boon, W.P.C. (2008) The role of users in innovation in the pharmaceutical industry. *Drug discovery today*, 13 (7-8), pp.353-359.
- Sneiders, H.H. (1984) Jiko la Dodoma' – the UTAFITI field test of an improved charcoal stove. *GATE Quarterly*, 2, p.16.
- Spalding-Fecher, R., Winkler, H. & Mwakasonda, S. (2005) Energy and the World Summit on Sustainable Development: what next? *Energy Policy*, 33 (1), pp.99-112.
- Stone, L.J. (2006) Limitations of cleaner production programmes as organisational change agents II. Leadership, support, communication, involvement and program design. *Journal of cleaner production*, 14 (1), pp.15-30.

Torero, M. & Chowdhury, S. (2004) Increasing access to infrastructure for Africa's rural poor. In: *2020 Vision Initiative of the International Food Policy Research Institute*. Kampala, Uganda, International Food Policy Research Institute (IFPRI), pp.1-6.

United Nations (2009) DSD: Areas of Work: Energy for Sustainable Development [Internet]. Available from: <http://www.un.org/esa/dsd/dsd_aofw_ene/ene_index.shtml> [Accessed 23 May 2009].

United Nations (2002) *Report of the world summit on sustainable development*. Johannesburg, South Africa. Available from:
<http://www.un.org/jsummit/html/documents/summit_docs/131302_wssd_report_reissued.pdf> [Accessed 29 April 2009].

Venkataraman, C., Habib, G., Eiguren-Fernandez, A., Miguel, A.H. & Friedlander, S.K. (2005) *Residential biofuels in south Asia: Carbonaceous aerosol emissions and climate impacts*. American Association for the Advancement of Science.

Wallmo, K. & Jacobson, S.K. (2002) A social and environmental evaluation of fuel-efficient cook-stoves and conservation in Uganda. *Environmental Conservation*, 25 (02), pp.99-108.

Wamukonya, L. (1995) Energy consumption in three rural Kenyan households: A survey. *Biomass and Bioenergy*, 8 (6), pp.445-451.

WHO (2005) Indoor air pollution and health [Internet]. Available from:
<<http://www.who.int/mediacentre/factsheets/fs292/en/print.html>> [Accessed 30 March 2009].

Worldwatch Institute (2009) *State of the World 2009: Into a Warming World*. 26th ed. London, WW Norton & Company.

Wozniak, G.D. (1993) Joint information acquisition and new technology adoption: late versus early adoption. *The Review of Economics and Statistics*, pp.438-445.

Yin, R.K. (2003) *Case study research: Design and methods*. London, Sage.

Internet/Web resources:

Burning Issues: [://www.burningissues.org/car-www/science/Energy-ladder.html](http://www.burningissues.org/car-www/science/Energy-ladder.html) accessed on the 28th of April, 2009

TaTEDO: [://www.tatedo.org/](http://www.tatedo.org/)

The Tanzania Government website: [://www.tanzania.go.tz/](http://www.tanzania.go.tz/)

8. Appendices

A: Interview schedule for improved stove users

1. When did you acquire the improved stove?
2. How did you know about the improved stoves?
3. What made (motivated) you decide to adopt the new technology?
4. Was/is it difficult to use the new technology?
5. Are there any benefits of the new technology over the old one?
6. Are there any differences between the old technology and the improved one?
7. If you were to ask for improvement of this (new) technology which features would you ask for?
8. Have you made any modifications to the new technology to suit your liking since you acquired it?
9. Have you been visited by stove experts since you acquired the stove?
10. What are the things you don't like about the improved stove?
11. What do you like the most about it?
12. Do you know of anyone else in this village using a similar stove?
13. If you were to abandon the stove, what would your reasons be?
14. On a scale of 1 to 10; ten being the worst and one being the best, how would you rank the new stove's efficiency regarding fuel wood use?

B: Interview schedule for former users who abandoned the stove

Key issues discussed were based and centered on the following basic questions:

1. When did you acquire your improved stove?
2. What made you abandon the stove?
3. What did you do about the problem before you reached the decision to abandon it?

C: Interview schedule for non-users:

Key issues discussed were based and centered on the following basic questions:

1. Have you ever heard about improved stoves?
2. Where was it that you heard about the stoves?
3. Why are you not using an improved stove?

D: Sample of interviews with key questions and answers from respondents

- Notes: 1. For ethical reasons all respondents are anonymous
2. Due to space limitations not all questions and answers are included

SN	Date	Area	Representative question, answer and comments (if any)
1.	29.01.2009	Sanya-juu	Question: Was it difficult for you to use the new technology? Answer: It was difficult. We did not know that once the stove has been constructed it needed time to get dry. Using it straight away without waiting for it to dry up was troublesome. But this difficulty lasts for about 2 – 3 days and once the stove has dried up; everything is fine.
2.	29.01.2009	Sanya-juu	Question: If you were to offer an advice to the designers of these stoves, what improvements would you suggest? Answer: I think it should remain as it is because when we were using the old technology we needed a lot of firewood but this stove does not need as much firewood.
3.	30.01.2009	Sanya-juu	Question: What exactly made you switch from the old technology to the improved one? Answer: we switched because of wood shortages, we saw this as a good alternative because it could save wood, natural resource authorities kept restricting the amount of wood we could get from the forest.
4.	30.01.2009	Magadini	Question: Why are you using both the improved and traditional stove Answer: The pan, as you can see, is too big to fit into the holes. When we constructed this stove, the number of pupils was less than we have now. So the stove was designed for smaller pans. That is why we have to use the old technology – to be able to meet the needs of the number of pupils we now have.
5.	31.01.2009	Sanya-juu	Question: Where or how did you get the information about improved stoves? Answer: Since the 1990s, in fact in 1995, people came from Germany through our church and they were educating us on basic health. Then later on, around the year 2000, came the organization called TaTEDO through Angaza (Women Center) and they taught us about the stoves. My son attended TaTEDO sessions and after that he constructed this stove.
6.	31.01.2009	Sanya-juu	Question: How much did it cost you to construct the stove? Answer: I don't know. My husband was the one supervising the work. I think he knows.
7.	02.02.2009	Sanya-juu	Question: How did you get informed about improved stoves? Answer: It is not about getting informed. I think this is like a fashion. Nowadays people who are building good houses are also installing these modern stoves.

SN	Date	Area	Representative question, answer and comments (if any)
8.	02.02.2009	Sanya-juu	<p>Question 1: What do you think is so good about an improved stove?</p> <p>Answer: this one is more durable; it is easy to use and cooks faster</p> <p>Question 2: If you were to suggest any feature for improving this technology even more, what would your suggestion be?</p> <p>Answer: I think smoke is still a problem. Something should be done about chimneys. As you can see; the walls and roof are stained with soot. Another thing is, if possible, they should construct it in such a way that it is possible to cook while standing (<i>elevate it more</i>).</p>
9.	03.02.2009	Sanya-juu (Note: <i>abandoned stove</i>)	<p>Question: Did you ever use the improved stove at all?</p> <p>Answer: Yes, we used it for a while before it started giving us problems. It was too smoky and more difficult to light and make fire. I think you should come with me and see it. I am no longer using it.</p>
10.	03.02.2009	Sanya-juu	<p>Question: Who built this improved stove for you?</p> <p>Answer: My husband. He is a contractor/mason; he saw these stoves in other people's homes and he decided to construct this but in a slightly different way.</p>
11.	04.02.2009	Magadini (<i>another abandoned case</i>)	<p>Question 1: What is the problem here?</p> <p>Answer: It seems like the chimney is blocked/clogged, a lot of smoke in the kitchen</p> <p>Question 2: Does it bother you and what do you do?</p> <p>Answer: Yes, it bothers me very much. I am currently not using it</p>
12.	04.02.2009	Magadini (<i>with artisans</i>)	<p>Question: What are some of your experiences in disseminating improved stoves?</p> <p>Answer: There are some people here in the village who do not accept this new technology very easily. When you tell them about it they claim that these new stoves are not as suitable for indoor heating as the open fire from three-stone stoves. Some of them, like my father, will even tell us to go and disseminate this technology in households with learned and richer people. He thinks installation of improved stoves is wastage of money.</p>
13.	05.02.2009	Moshi (<i>with TaTEDO expert</i>)	<p>Question 1: How difficult or easy is it to clean chimneys of improved stoves?</p> <p>Answer: It is fairly easy: one has to climb up the roof, pour water into the chimney and brush the accumulated carbonic material down the chimney.</p> <p>Question 2: Do you think that is easy for women and children to do?</p> <p>Answer: It might be somewhat difficult for women and younger children. They probably could get help from husbands, older children or technicians.</p>

SN	Date	Area	Representative question, answer and comments (if any)
14.	19.02.2009	Kuze-Kibago (<i>village guide</i>)	Question: So why is it that not everyone in this village has the improved stoves considering all the benefits these stoves have? What do you think is the problem? Answer: We (most people in the village) wait for the technicians to come to us and construct the stove. We think it is their job to go from house to house constructing the stoves. So if we don't have the stoves, it is because no technician has showed up yet.
15.	19.02.2009	Kuze-Kibago	Question: Have you ever been visited by the people who constructed the stove to see how you are using it? Answer: No. You are the first visitor to come asking about the stove.
16.	19.02.2009	Kuze-Kibago	Question: If you are no longer using the traditional stove, then why is it still there? Answer: Well if I have more than one pan that I need to cook my food in; I have to make use of both the traditional and the improved stove. But if I have only one pan I prefer to use the improved stove. Now I'm so used to using the new stove that I get difficulties handling the traditional one.
17.	20.02.2009	Kuze-Kibago (<i>non-user</i>)	Question: Why are you not using an improved stove in your household? Answer: I will have/get one soon. I want to build a good kitchen first.
18.	20.02.2009	Kuze-Kibago (<i>non-user</i>)	Question: If you know that an improved stove saves firewood, why then you don't get one? Answer: I will get one soon. It is just that I haven't seen the technician yet.
19.	21.02.2009	Kuze-Kibago	Question: I see you also still have your traditional stove. Any reasons? Answer: Emergency, but also extra. You sometimes need to cook in more than one pan/pot so you make use of the other stove as well. But also incase of damage to the new stove, and then we can use the traditional one. (<i>But as I look around I realize there is a bunch of maize hanging right above the traditional stove – dryer</i>).
20.	21.02.2009	Kuze-Kibago	Question: How much did you pay for the stove? Answer: No, I did not pay him as such. I just gave him 500 shillings as a thank you.
21.	23.02.2009	Kuze-Kibago	Question: When the stove gets damaged, what do you do? Answer: I repair it myself. It is easy. You take a small portion of ashes; mix it with soil and water. You then apply that mixture to the damaged part of the stove. (<i>This is another difference between these users and those in Sanya-juu and Magadini – the ability of users to repair stoves when they get damaged</i>).

SN	Date	Area	Representative question, answer and comments (if any)
22.	23.02.2009	Kuze-Kibago (<i>stove technician and expert</i>)	Question: What is the situation of stoves dissemination like? Answer: Most people who use firewood live either in rural villages or in the fringes of the town. They don't live in the town centre. Most of the people in the town center prefer to use charcoal. I would say that we will start feeling the difference when stove users will start seeking stove makers. But now it is mainly us stove makers who go out looking for stove users and telling them about this technology. There is some progress though: I would say we are slowly starting to see the mixture of the two: sometimes potential users come looking for us and at some other time we go out looking for them. The market is not yet totally demand-driven.
23.	24.02.2009	Kuze-Kibago (<i>a group of charcoal stove makers</i>)	Question: Who is the targeted user of this type of stove? By its outlook it doesn't seem to be durable. What can you guys comment on that? Answer: Anybody can use this stove. It does not have many differences from the traditional charcoal stove. The only difference is that instead of being entirely metallic, this one has clay on the inside to conserve heat. The more a user continues using the stove, the stronger it becomes because the user will be heating this clay and heat makes clay stronger.
24.	24.02.2009	Kuze-Kibago	Question: Apart from firewood saving, what other benefits do think this improved stove has over the traditional one? Answer: When it is windy, fire does not spread out. If you are using the traditional three-stone stove and wind comes, fire is blown sideways and you don't get the same heating effect.
25.	25.02.2009	Kuze-Kibago	Question: I believe before you got your improved stove you were using a different stove. What made you switch from using your old stove to the improved one? Answer: This is more economical. There is only one firewood inlet. But with the old stove There were three firewood inlets. So I was using more firewood. You see, with this stove I have two fire holes (<i>or potholes</i>) while I insert firewood into only one inlet. So I can cook on two pans at once.
26.	25.02.2009	Kuze-Kibago	Question: Had you heard about improved stoves before you got one? Answer: I come from Lushoto (<i>another different district</i>) and in Lushoto these improved stoves are very common. So I used it before we migrated to here. When I came here I found that it was not common. So I started using three-stone and charcoal stove. I was very happy when the technician came and said he would construct an improved stove for me.