

2022-07

Design of an automatic escaped animal detection and monitoring system: a case study of Volcanoes National Park (VNP)

Zirakwiye, Innocent

NM-AIST

<https://doi.org/10.58694/20.500.12479/1594>

Provided with love from The Nelson Mandela African Institution of Science and Technology

**DESIGN OF AN AUTOMATIC ESCAPED ANIMAL DETECTION AND
MONITORING SYSTEM: A CASE STUDY OF VOLCANOES
NATIONAL PARK (VNP)**

Innocent Zirakwiye

**A Project Report Submitted in Partial Fulfilment of the Requirements for the Degree of
Master of Science in Embedded and Mobile Systems of the Nelson Mandela African
Institution of Science and Technology**

Arusha, Tanzania

July, 2022

ABSTRACT

The results have been shown that the people especially farmers living at the edge of Volcanoes National Park (VNP) practiced agricultural business due to the fertile soil found in the region. The rising number of agronomies in the zone, number of tourists, and illegal forest users such as poaching, and deforestation cause wild animals to get out of their habitats. Therefore, their crops are raided by forest animals which present a likely risk to damage crops whenever they get out of the forest. The current systems such as “Buffer Wall also known as wall of stones” was manually operated; electric fence systems resulted in death and pain to wild animals. Due to the development of automatic systems for detecting and monitoring all moving wild animals and intruders, it was stated that using automation at Buffer wall could be helpful for both wild animals and farmers keep safe. Security is an importance in the VNP whereby detection and monitoring wildlife would determine the needs by park officials. The objectives of developing an Automatic Escaped Animal Detection and Monitoring System were to reduce the probability of crop raids, death and injuries between wild animals and farmers, warning the wild animals through the use of buzzer, speaker with a recorder voice of lion and block of LEDs to remain in their habitats and the notifications sent to the park officials related to the forest animals getting out of the forest. Since wild animals and intruders found in buffer zone targeting to pass by the buffer wall for crop raiding and poaching activities; this system should primarily use sensing devices to detect and monitor their presence. On the other hand, for buffer wall security, warning equipment’s such as block of LEDs, Buzzer, SIREN Alarm and speaker should all together be activated. Whenever wild animals and trespassers would search to pass by another part would be activated the same way as the previous. The specialty of this technological system developed was to automate manual and improve the current systems by using Arduino NANO Microcontroller to execute system’s operations, GPS NEO 6M for locating moving wild animal, Ultrasonic sensor for detecting wildlife and calculating its speed, PIR sensor to detect intruders, GSM SIM900 to notify park rangers, reduction of crop raiding, and finally reducing death and pain of wild animals caused by current systems.

DECLARATION

I, Innocent Zirakwiye, do hereby declare to the Senate of Nelson Mandela African Institution of Science and Technology that this project report is my original work and that it has neither been submitted nor being concurrently submitted for degree award in any other institution.

Innocent Zirakwiye



20.07.2022

Name of Candidate

Signature

Date

The above declaration is confirmed by:

Prof. Kisangiri Michael



22.07.2022

Name of Supervisor 1

Signature

Date

Dr. Jema David Ndibwile



22.07.2022

Name of Supervisor 2

Signature

Date

COPYRIGHT

This project report is a copyright material protected under the Berne Convention, the copyright Act of 1999 and other International and National enactments, in that behalf, an intellectual property. It should not be reproduced by any means, in full or in part, except for short extracts in fair dealing, for research or private study, critical scholarly review or discourse with an acknowledgement and without a written permission of the Deputy Vice Chancellor for Academic, Research and Innovation, on behalf of both the author and the Nelson Mandela African Institution of Science and Technology.

CERTIFICATION

The undersigned certify that they have read and hereby recommend for acceptance by The Nelson Mandela African Institution of Science and Technology, a project report titled, “*Design of Automatic Escaped Animal Detection and Monitoring System: A Case Study of Volcanoes National Park (VNP)*”, in partial fulfillment of the requirements for the degree of Master of science in Embedded and Mobile Systems of the Nelson Mandela African Institution of Science and Technology.

Prof. Kisangiri Michael



22.07.2022

Name of Supervisor 1

Signature

Date

Dr. Jema David Ndibwile



22.07.2022

Name of Supervisor 2

Signature

Date

ACKNOWLEDGEMENTS

First of all, I would like to thank The Almighty God for his blessings, grace and guidance during our time as a student in Embedded and Mobile Systems at NM-AIST Arusha Tanzania. The Almighty God helped me to successfully accomplish whatever I have been just planned

Secondly, I would like to express my sincere gratitude to our supervisors Prof. Kisangiri Michael and Dr. Jema David Ndibwile, who have been with us throughout the process of conducting this project for their assistance, advice, constructive and practical feedbacks. They were with me for all time during online and offline meetings and discussions which helped to improve and produce my project report.

I would sincerely like to thank our sponsors CENIT@EA that supported the finances and other valuable materials on completing this project and profound gratitude also goes to lecturers and the EMoS class 2020/2021 for their immense support during this project. I would like to give my thanks to HOBUKA Ltd community for their inputs and their insightful comments.

Finally, I would like to express my sincere gratitude to the entire family and guardians for their support, prayers, and blessings during my graduate studies.

God bless you all!

DEDICATION

I devote this work to my esteemed wife Ms. Jacqueline UZAMUKUNDA for her committed time, ideas and encouragement that strengthened me during the entire academic journey.

TABLE OF CONTENTS

ABSTRACT.....	I
DECLARATION	II
COPYRIGHT.....	III
CERTIFICATION	IV
ACKNOWLEDGEMENTS.....	V
DEDICATION.....	VI
TABLE OF CONTENTS.....	VII
LIST OF TABLES.....	XI
LIST OF FIGURES	XII
LIST OF APPENDICES.....	XIII
LIST OF ABBREVIATIONS AND SYMBOLS	XIV
CHAPTER ONE.....	1
INTRODUCTION	1
1.1 Background of the Problem	1
1.2 Statement of the Problem.....	2
1.2.1 Poachers	3
1.2.2 Forest Rangers.....	3
1.2.3 Crop Foraging	3
1.2.4 Agricultural Encroachment	3
1.2.5 Scarcity of their Food in the Park.....	4
1.2.6 Unprotected/weak Protections between Fields and Forests	4
1.2.7 Natural Factors	5
1.3 Rationale of the Study.....	5
1.4 Objectives	5
1.4.1 Main Objective.....	5
1.4.2 Specific Objectives.....	5
1.5 Research Questions	6
1.6 Significance of the Study	6

1.7	Delineation of the Study	6
CHAPTER TWO		8
LITERATURE REVIEW		8
2.1	Overview of Volcanoes National Park	8
2.2	Case Study	9
2.3	Agricultural Practices.....	9
2.4	Digital Forestry	9
2.4.1	Sensors	9
2.4.2	Safety at Buffer Wall (Buffer Zone)	10
2.5	Importance of ICT in Conservation Monitoring and Control.....	11
2.5.1	Significance of Buffer Wall Detection and Monitoring.....	11
2.6	Design of an Automatic Buffer Wall/Fence Block.....	12
2.7	Related Works.....	13
CHAPTER THREE		15
MATERIALS AND METHODS.....		15
3.1	Study Area	15
3.2	Project Design.....	15
3.2.1	Agile Methodology	16
3.3	Wild Animals Detection Devices.....	16
3.4	Classification of Warning Devices	17
3.4.1	Movement Detection Sensors.....	17
3.4.2	Light Emitting Diodes (LEDs).....	18
3.4.3	Buzzer.....	19
3.4.4	Siren Sound Alarm	19
3.4.5	Speaker	20
3.4.6	Liquid Crystal Displays (LCD).....	20
3.4.7	Potentiometer	21
3.4.8	GSM SIM900 Module.....	21
3.4.9	Relay.....	23
3.4.10	Global Positioning System (GPS NEO 6M)	23
3.5	Microcontrollers.....	24
3.5.1	Arduino NANO	24

3.5.2	Advantages of Arduino NANO.....	26
3.5.3	Errors Correction Methods and System Maintenance.....	26
3.6	Power Consumption.....	26
3.7	Data Transmission	27
3.7.1	Fiber Optic Cables (FOC)	27
3.7.2	Wireless Communications (Wi-Fi) Technology	28
3.8	System Requirements.....	28
3.9	Functional and Non-Functional Requirements	28
3.9.1	Functional Requirements.....	29
3.9.2	Non-Functional Requirements	29
3.10	Project Area	29
3.11	System Implementation	30
3.11.1	Sensing Part.....	30
3.11.2	Actuation Part.....	31
3.11.3	Selecting Sensors.....	31
3.11.4	Arduino Integrated Development Environment (IDE)	31
3.11.5	Fritzing	32
3.11.6	EasyEda.....	32
3.12	System Testing.....	32
CHAPTER FOUR.....		34
RESULTS AND DISCUSSION		34
4.1	Results of the System Design Process	34
4.1.1	The Major Causes of Crop Raiding	34
4.1.2	Existing Buffer Wall System at VNP.....	36
4.1.3	Challenges of Existing Buffer Wall Systems.....	36
4.1.4	Description of the Designed and Developed System.....	37
4.1.5	Design of System Block Diagram.....	38
4.1.6	Parameters for Systems	38
4.1.7	Circuit Diagram Design	39
4.1.8	Block Diagram Architecture	40
4.1.9	Data Flow Diagram	41
4.1.10	Choosing Sensing Components.....	42
4.1.11	Sensors and Actuators Connections	43

4.1.12	System Testing and System Validation.....	43
4.1.13	System Performance Test.....	44
4.2	Discussion.....	45
4.3	Limitations.....	46
CHAPTER FIVE		47
CONCLUSION AND RECOMMENDATIONS		47
5.1	Conclusion	47
5.2	Recommendations.....	47
REFERENCES		49
APPENDICES		54

LIST OF TABLES

Table 1: Negative impacts of wildlife to the community	11
Table 2: Advantages of ultrasonic and PIR sensors.....	18
Table 3: Characteristics of Arduino NANO	25
Table 4: Types of Respondents.....	34
Table 5: Data sensed and sent to notify park officials	44

LIST OF FIGURES

Figure 1:	Buffer wall (NBSAP, 2016) and Gorillas in potato field (NBSAP, 2016)	4
Figure 2:	Accidents of animals trying to pass an electric fence (Division & Fish, 2008)	5
Figure 3:	Volcanoes National Park map (NBSAP, 2016).....	7
Figure 4:	An automatic buffer wall.....	12
Figure 5:	Agile Methodology.....	16
Figure 6:	(a) Ultrasonic Sensor and (b) PIR Sensor	17
Figure 7:	Block of LEDs.....	18
Figure 8:	Buzzer device	19
Figure 9:	SIREN Alarm device.....	19
Figure 10:	Speaker	20
Figure 11:	LCD Display.....	21
Figure 12:	GSM SIM900 Module.....	22
Figure 13:	Relay.....	23
Figure 14:	GPS NEO 6M.....	24
Figure 15:	Arduino NANO	25
Figure 16:	VNP (Park, 2019).....	30
Figure 17:	Type of crops found in VNP	35
Figure 18:	Distance (in metrics) between the park and farming fields.....	35
Figure 19:	Distance (in metrics) from the park to the house/community	36
Figure 20:	Proposed System	37
Figure 21:	The schematic diagram for the automatic buffer system	40
Figure 22:	The building block of the system architecture design.....	40
Figure 23:	Data flow diagram of events and controls for the system designed.....	41
Figure 24:	Connection of sensors and actuators	43
Figure 25:	SMS Notifications: (a) IN ALERT! And (b) OUT ALERT!	45

LIST OF APPENDICES

Appendix 1: Datasheet of Ultrasonic (Indoware, 2013)	54
Appendix 2: Arduino IDE Datasheet (Farnell, 2013).....	55
Appendix 3: GSM SIM900 (Shield, 2014).....	56
Appendix 4: GPS NEO 6M (Neil, 2010).....	57
Appendix 5: Automatic Buffer Wall Setup	58
Appendix 6: LCD Display Outputs.....	59
Appendix 7: PIR Sensor datasheet (Description, 2011)	60
Appendix 8: The Automatic Escaped Animal Detection and Monitoring System codes.....	61
Appendix 9: Poster Presentation.....	70

LIST OF ABBREVIATIONS AND SYMBOLS

AC	Alternative Current
AI	Artificial Intelligence
ANP	Akagera National Park
BPS	Byte per Second
COM	Common
DC	Direct Current
EAC	East African Community
EMoS	Embedded and Mobile Systems
FOC	Fiber Optic Cables
Frw	Rwandan Francs
GDP	Gross Domestic Product
GPS	Global Positioning System
GSM	Global System for Mobile communication
I/O	Input Output pins
ICT	Information and Communication Technology
IDE	Integrated Development Environment
IoT	Internet of Things
IR	Infra-Red sensor
LCD	Liquid Crystal Display
LEDs	Light Emitting Diodes
LoRa	Long Range
MHz	Megahertz
MTN	Mobile Telephone Network

NBSAP	National Biodiversity Strategy and Action Plan
NC	Normally Closed
NISR	National Institute of Statistics of Rwanda
NM-AIST	Nelson Mandela African Institution of Science and Technology
NO	Normally Open
ORTPN	Rwanda's Office of Tourism and National Parks
PCB	Printed Circuit Board
PDF	Portable Document Format
PIR	Passive Infrared
RCNN	Region Based Convolutional Neural Network
RDB	Rwanda Development Board
RFID	Radio Frequency Identification Device
Rx	Receiver
SIM	Subscriber Identity Module card
SMS	Short Message Service
TCP/IP	Transmission Control Protocol/Internet Protocol
Tx	Transmitter
UART	Universal Asynchronous Receiver Transmitter
USB	Universal Serial Bus
VPN	Volcanoes National Park
Wi-Fi	Wireless Fidelity
WSN	Wireless Sensor Network

CHAPTER ONE

INTRODUCTION

1.1 Background of the Problem

The Republic of Rwanda is a country of thousand hills. Rwanda is also a landlocked country located in the East African Community (EAC) and it has no oil and petroleum products except its population and attracting tourists to earn money for its development. Rwanda is surrounded by forests: Akagera National Park (ANP), Nyungwe National Park and Volcanoes National Park (VNP) which expands in the Northern and Western Provinces with a distance of 60 Km (Hurni, 1986).

Volcanoes National Park (VNP) consists of five volcanoes such as Karisimbi, Sabyinyo, Muhabura, Gahinga and Bisoke. Volcanoes National Park is full of animals which attract tourists; notably gorillas, golden monkeys, buffalos, chimpanzees, black-front duiker, bushbuck, elephants and so more. The Republic of Rwanda earns USD 498 million in tourism according to the 2019 report (Annual Report, 2019). This is very soil fertility that mixture of crops including potatoes, beans, sorghum, wheat, peas, pyrethrum, and maize are used as food; the pyrethrum is founded along the western part of the park.

In Rwanda, like other countries with wildlife, forest animals lead to their economic development, whereby the Government of Rwanda has got approximately USD 1.7 million (Munanura *et al.*, 2016).

The farmers around the National Park practice agricultural activities to get the highest and the best yields. Many times, the wildlife gets out of the forest to raid the crops of the population and they return home in vain.

The Republic of Rwanda through its Wildlife policy (Kigali, 2017) and Forestry policy (Government of Rwanda, 2018) tried to protect not only the population around the VNP but also the wild animals found in VNP by using Buffer wall at edges of the VPN as the barriers of wildlife getting out of the forest for crop raiding. However, farmers reported that despite the efforts of building a wall around the boundaries of the park, wild animals still render their farming products.

In the Coffa forest eastern zone of Tigray Ethiopia, there was a human-wildlife conflict an interaction between humans and animals resulting negative impacts on human social, economic or cultural life. Because 47.5% confirmed crop raiding and cattle damage was the main form of damage in the area even if walls were used and the local residents suffered for hunger while Ethiopia tried to combat poverty reduction by investing in agriculture, and the result was the crops raid by wildlife (Girmay & Teshome, 2015).

Virtual fencing was developed to break cows during rotational grazing systems. It was used to control the localization of animals daily and can be defined as the barrier, or boundary of a grazing zone without a physical wall or fence. This technology was a complex grazing system used to monitor cattle in the area, during grazing they cannot approach and raid crops in the fields around. To use virtual fence localization, Global Positioning System (GPS) was developed (Langworthy *et al.*, 2021) but the issues of breaking out of animals remained constant.

However, the conflict among forest animals and farmers continues unsolved. Weak barriers at the buffer zone resulted in crop raiding and the people experienced food shortage in their families and there remain the issues of compensating the residents whose crops are damaged by animals, it is not an adequate cater method and people whose relatives were killed by animals have not been compensated by Rwanda Development Board (RDB). The farmers get their harvest if and only if they make patrols day and night over their crops and it is still a big problem to record the crops raided, houses destroyed, paying hospital's bills for residents injured by wild animals and people killed by wild animals.

1.2 Statement of the Problem

There are multiplicities of reasons why crop raiding occurs. Most of them take place at Buffer wall when wild animals try to move out of the forest.

Next to VNP, farmers practice agricultural business. Animals getting out of the forest for crop raiding, buffalos kill people and people kill them. Thus, there is a conflict between farmers and the Government on how they will be compensated for the damage of their crops raided by forest animals.

Whereas every case is unique, the most common causes of crop raiding include poachers, forest rangers among others as discussed below:

1.2.1 Poachers

Poaching is an illegal activity and hunting and killing wildlife done in the forest by unauthorized people. Poachers do poach in order to get food, illegal wild animal's trade, and the Money. Poaching caused by population growth and poverty both resulted in numerous problems for the wild animals; people increased while lands remained the same, lack of food to the community; people migrated from rural areas to urban areas and they created markets for bushmeat (Obour *et al.*, 2016). From 2006 to 2018, poaching activities are shown by 84 poachers arrested and 17 130 Snares were removed by park rangers during their patrol only in Musanze District, the Government established the policy to share 10% of the tourism's revenue to the community living at the edges of the park (Uwayo *et al.*, 2020). Those animals fled from poachers and hunters; they often crossed the forest and reached the fields of the farmers and raided their crops (Obour *et al.*, 2016).

1.2.2 Forest Rangers

The park rangers are the special people protecting wildlife and environment and protecting parklands in a limited boundary. Whenever rangers make little mistakes of their responsibility and look sideways, wild animals get out of the forest and destroy the crops of farmers.

1.2.3 Crop Foraging

People around the do farming activities including the plants related to the region-soil in which wild animals get different types of food. The wildlife gets out of the forest for damaging crops of the farmers. The crop raiders can crop the half and/or whole field for food and the farmers return home without yielding. Wild animals engaged in foraging are at higher dangerous risk of being killed by farmers (Hill, 2019).

1.2.4 Agricultural Encroachment

The growth of people in some countries pushes them to encroach the forest land illegally and the cutting down of the forests causes animals to flee and lose food. These agricultural activities make wild animals to starve for food and then wildlife return to the farmers' fields for crop raiding.

When neighbors of the forest make encroachment, the animals lose their habitats and food and they come back to raid the crops of farmers.

1.2.5 Scarcity of their Food in the Park

The forest animals' Hunger is caused by the shortage of food because of unauthorized activities done aside of the forest such as deforestation, environmental factors such as climate change, natural disasters such as flood, fire, volcanic eruption and so more all resulted the crisis of food in the park and animals migrate into farmers' fields for raiding their crops (Fawole *et al.*, 2017).

1.2.6 Unprotected/weak Protections between Fields and Forests

The edges of Volcanoes National Park are surrounded by the built traditional walls of stones and ditches; however, buffalos and monkeys, Gorillas and other wild animals jump the wall for crop raiding.

The neighborhood of VNP residents knows well that there are lots of unprotected fences across the edges of the forest. Crop raiding at unprotected fence is most often originated by:

- (i) Traditional methods such as buffer wall and ditches
- (ii) Poor visibility;
- (iii) The plants are closer to the forest;
- (iv) Farmers plant likely plants by wild animals.



Figure 1: Buffer wall (NBSAP, 2016) and Gorillas in potato field (NBSAP, 2016)

Weak Protections between Fields and Forests favor forest animals to get out of the forest and raid crops.

Technology such as electric fences, used for protecting crops has a negative impact on the animals which are getting in and out of the forest (Hanophy, 2009).



Figure 2: Accidents of animals trying to pass an electric fence (Hanophy, 2009)

1.2.7 Natural Factors

Unpredictable hazards such as fire in the forest, climate change, forest droughts and so on, cause the wildlife to lose their habitats and escape the forest toward the community and raid their crops (Paper, 2008).

1.3 Rationale of the Study

The Republic of Rwanda is recently pacing the development of tourism and conservation such that the “Kwita izina” Gorilla naming ceremony is known all over the World (Izina *et al.*, 2018). Daily announcements via Televisions, local journals and Radio’s herald accidents happening at VNP, crop raiding, complaints of farmers for compensation of their crops, people in hospitals, deaths and so on. Significant number of casualties, injuries, destruction of infrastructures such as buffer wall, ditches, buildings and plans. Now the buffalo fence is being reactivated, this system would serve a huge purpose in improving the buffalo fence infrastructure to help the farmers and the population around the edges of the forest to make stronger safety.

1.4 Objectives

1.4.1 Main Objective

The main objective of this project was to develop an Automatic system for detecting and monitoring escaped animals getting out of the VPN for crop raiding.

1.4.2 Specific Objectives

- (i) To review and analyze the requirements for developing an Automatic Escaped Animal Detection and Monitoring System.

- (ii) To design and develop an Automatic Escaped Animal Detection and Monitoring System.
- (iii) To validate the developed system.

1.5 Research Questions

All harming done at VNP are unfortunately reasons which prove the loss of life, crop raiding, destruction of infrastructures and a lot of injuries in the zone.

The proposed Automatic Escaped Animals Detection and Monitoring system is the solution of queries asked by all forest users such as the Government, people around the edges of the forest and Tourists and to assess the gap and risks to better reduce wild animal crop raiding in the VNP zone:

- (i) Are the buffer walls, fences and ditches currently used still relevant for securing and notifying farmers and park rangers?
- (ii) How much budget is spent by the government to repair and compensate all damaged infrastructures, deaths, and injuries?
- (iii) How to ensure the developed system meet the specified requirement?

1.6 Significance of the Study

The developed system helps to prevent crop raiding for animals getting out of the forests to raid maize, Irish potatoes, plants and more; to reduce destruction of land, fence, and buildings; to avoid deaths of animals and human beings; to raise awareness to the community about conservation; notifying all concerned people to the wildlife; there would be no workforce required; and to automate operation prevents errors from manual operation.

1.7 Delineation of the Study

The project delineates in Rwanda, purposely VNP. According to RDB, the VNP has a big number of visitors and tourists whereby 1.7 million tourists visited VNP for the 2018 year. VNP, it has a surrounding good land for many crops which are likely by wild animals.

That big number of wild animals, tourists and abundant plants in the region resulted in the movements of wild animals and passed the buffer zone for crop raiding. The goals and

objectives of this project are to produce an automatic Buffer wall block to reduce damages happening when wild animals cross the buffer zone to raid crops.

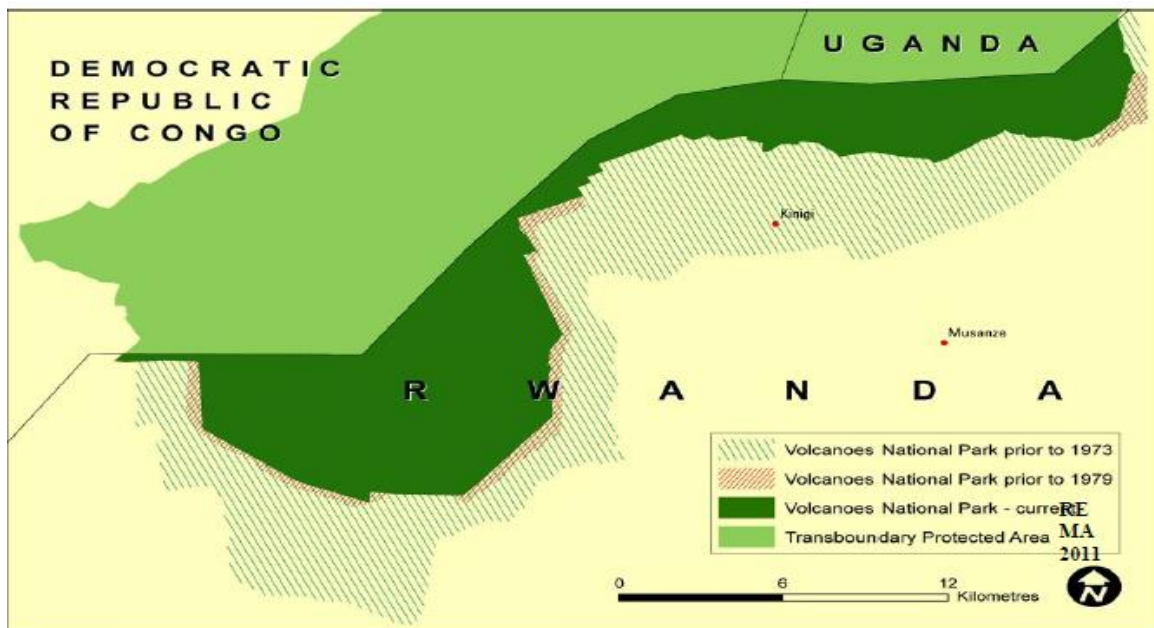

Figure 3: Volcanoes National Park map (NBSAP, 2016)

CHAPTER TWO

LITERATURE REVIEW

2.1 Overview of Volcanoes National Park

The need for an automatic system at the Volcanoes National Park at the buffer zone has created a center of attention of the scholars for the preceding few years for conservation security.

Volcanic soil is considered as the one of the most suitable for plants in the World. Such soil attracts farmers to produce agricultural business but unfortunately their crops are raided by wild animals. Engineers and researchers from all over the World are trying to construct intelligently supervised automatic fence block control systems (Division & Fish, 2008)

The Volcanoes National Park located in Northern and Western Provinces spans a total distance of 60 Km (Hurni, 1986) with a huge number of wildlife. From 2008 to 2012, 27 885 foreigners visited VNP (NISR, 2015). Rwanda Development Board (RDB), have recorded 36 000 visitors visited VNP (RDB, 2020). Concerning National Parks, from 2013-2018, RDB received 7 659 claims with different cases such as crops raided by forest animals, livestock killed, death and injured people whereby a total of FRw 580 106 575 million was established to compensate the above claims (Park & Oort, 2020). Therefore, the farmers around parks are not happy with insufficient value credited to their properties, as shown by only 16.1% of the farmers have received financial compensation for their raided crops by wild animals (Park, 2019).

Therefore, when it comes to buffer zone functions across the VNP, whereby wild animals pass for crop raiding, safety is one of the most central considerations. With the ever-increasing number of farmers, the buffer zone always encounters many problems due to technological and wild animals starving in the forest.

The buffer zone started with a ditch that is a separation section between the forest and farmers' fields. In most cases, the stone wall tends to show little protection against wildlife. Hence, such a wall needs constant forest rangers for coordinating and monitoring on an every day and night basis. In particular, a significant preponderance of buffer wall events occurs when wild animals are crossing the buffer zone. In the majority of cases, raiding crops and accidents occurred as a consequence of weak and unprotected buffer walls, animals' starved or plants most likely by wild animals (Fish & Service, 2001).

2.2 Case Study

The Republic of Rwanda has a lot of parks such as Akagera National Park (ANP), Nyungwe National Park, Volcanoes National Park (VNP) and Gishwati National Park; all together contain wild animals which damage crops of the farmers, kill people around the edges of the forest and vice-versa and at ANP they used Electric fence which ethically resulted negative impact with wild animals. This study was carried out in the Volcanoes National Park (VNP).

2.3 Agricultural Practices

The Rwandan Agricultural business is the key economic activity that is practiced in the whole country especially the Northern Province which is the richest volcanic soil. Rwanda is a small country with 26 338 km² and with 11 809 295 people in 2017 (MINALOC, 2018). The economy is based primarily on agriculture whereby 91.1% of the Rwandese are farmers and this sector supplies 36% of the Gross Domestic Product (GDP) (IPAR, 2009).

2.4 Digital Forestry

Forests are plants created naturally with no involvement of human being. They may contain planted trees, water, animals, the soil rich in mineral salts on its edges (Carle & Holmgren, 2003).

The digital forests are described by planting, managing and helpful for forest. The use of digitalization technology in the forests, it is to offer real-time monitoring of the forests that takes account of the creation of interlinking with animals and virtual reality (Singh *et al.*, 2021).

2.4.1 Sensors

The sensors identify and react to events from the physical surroundings. They are positioned at one and/or both ends of buffer zone trips and sense the coming of the moving animals. The input sensor could be movement, a light, heat, moisture, pressure. Sensing technology is differentiated by identifying digital information and accurately process communication concerning the present state of the physical atmosphere (Singh *et al.*, 2021).

Types of Sensors that detect the coming of wild animal at the buffer wall could be characterized by the following (Lev *et al.*, 2017):

- (i) PIR sensor. This sensor uses the energy received to detect the presence of both intruder and wild animal objects;
- (ii) Infra-Red (IR) sensors functions on the standard of heat being produced by the object; IR Sensor is used to sense wild animal hidden in the crops;
- (iii) Accelerometers. It is a sensor used to study the behavior of animals for measuring its posture and motion of the body; and
- (iv) Vibration sensor: It is a sensor that uses the piezoelectric effect of the vibration in the pathway and detects the wild animal coming to the buffer wall. The vibration sensor output is given into the micro-controller which operates the buffer wall.

2.4.2 Safety at Buffer Wall (Buffer Zone)

Buffer walls started by ditches are special areas around parks built to sustain environmental integrity for the public and their participation in conservation and Tourism and are used to ensure the security among humans and wild animals' conflicts (Lamichhane *et al.*, 2019) and they intersect parks and farmers' fields. They are the areas set up for the security of a precise conservation region. They are used to secure wild animals, population and their crops from wildlife getting out of the forest. Transitional zones are used to reduce the impact of humans and conservation areas (Ebreg & Greve, 2000). Transitional zones used mostly at National Parks are positioned inside the delineated frontier of the park.

For these motives listed above, buffer zones should be studied independently because they comprise a key root of safety, accidents and crop raiding; this is the reasons to utilize a system to handle the security level provided to population and farmers around the park and their properties.

The Automatic fence block management signifies the entire process and methodology fence developers have to follow through the design process, construction process, operation process and maintenance process, all include:

- (i) Warning wild animals searching to get out of the forest;
- (ii) Securing the passage of wild animals through the buffer wall and buffer zone;
- (iii) Reducing the chance of accidents at electric fence to the least point as possible;
- (iv) To warn the peoples' access to the area; and

- (v) Keeping up the cost of process of the fence Block and the protection of its equipment at tolerable stages.

Table 1: Negative impacts of wildlife to the community

Causes of Incidents	Consequences
Buffer wall operation	(i) Liability of the park rangers
	(ii) Liability of ditches
Infrastructure of the Buffer wall	(i) Destruction of buffer wall
	(ii) Destruction of buildings
	(iii) Failure of the Buffer wall
	(iv) Weak and Poor construction of the stones
Scarcity of food in the park	(i) Hunger
	(ii) Crop raiding
	(iii) Death of wild animals and people
Faulty wall construction	(i) Improper and insufficient safety
	(ii) Violation of buffer wall rules
	(iii) Wrong plan and maneuver

2.5 Importance of ICT in Conservation Monitoring and Control

Information and Communication Technology (ICT) is used to make a smart conservation of parks' animals by gathering them, investigating data, and to assess illegal poaching. By using sensor technologies, park rangers could detect and monitor huge amounts of information concerning wildlife and warn illegal activities (Berger-Tal & Lahoz-Monfort, 2018).

2.5.1 Significance of Buffer Wall Detection and Monitoring

Buffer wall is a fence of stones built in a specific zone to separate housing zones and/or farming zones and the park.

Buffer wall is used to monitor, control and to alert unauthorized people entering in the park for illegal poaching; and animals getting out of the forest. This wall blocks all the in and out movements in order to reduce accidents and crop raiding (Ebreg & Pol de Greve, 2000). Automating the fence block is connecting Sensors and actuators joined mutually with Microcontrollers as the computed system to actuate the buffer wall operations.

Currently, ICTs have been developed and they play an important function in conservation systems. Tourism companies whose primary mission is to expand tourism as major societal and economical activities for making foreign cash and caring Tourists; this sector uses ICT to develop safety communication in the parks, to provide admission to the voyage information and to design automatic systems in order to provide better services.

ICTs have major evidence that show in extremely the ways to which conservation systems are used; for example, ICT has the potential to monitor wild creatures from being sensed, detected, and tracking poachers, to raise the public awareness in the population especially Youth by using social media and to form conservation ambassadors, the use of WildScan App to get wild animals illegal trade. In Rwanda, park rangers use iPhones for monitoring mountain gorillas. Geographic Information System (GIS) technology was developed with a multiple functions such as managing parks, reserves, environmental and conservation, warnings, forestry, atmosphere, and more (Parkash, 2017).

2.6 Design of an Automatic Buffer Wall/Fence Block

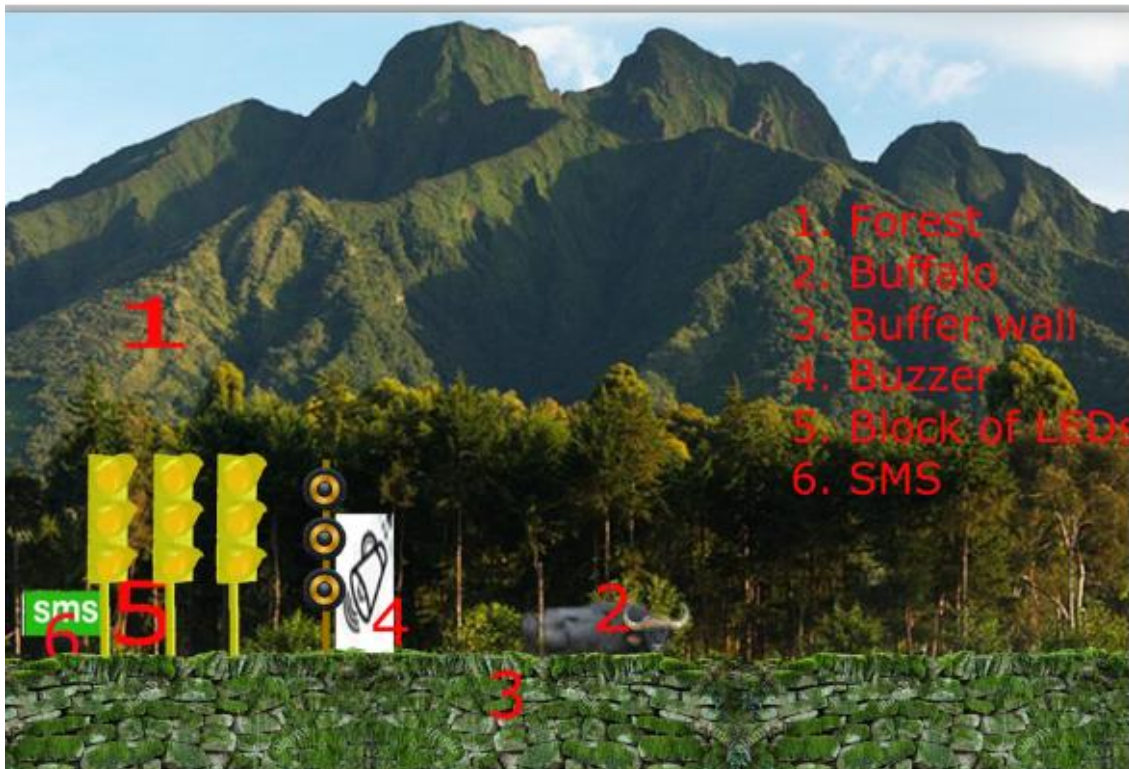

Figure 4: An automatic buffer wall

2.7 Related Works

The Automated Wild-animal intrusion Detection and Repellent System in India was designed to come up with the solution of reducing human-wildlife conflicts. Poaching and Hunting have obliged wild animals to leave their environments. The average of one person killed daily, and approximately 1 300 animals were passed away for the 2010-2020 years. The unlawful solutions of installing electric fencing are unsafe methods on each side. Many people around the zone lost their life and/or their crops. The Automated repellent System which used Artificial Intelligence (AI) and Internet of Things (IoT) and Raspberry pi was used to detect poachers and motion of moving animals and report them without delay. The Faster RCNN that was used as an Object Detection Architecture, it took many times to process, and it showed poor performance. The system used You Look Only Once (YOLO) which has low recall and remembering and localization error and not easy to detect smaller moving objects (Patil & Ansari, 2021).

Prof. Divya and Prof. Usha Kiran developed the Internet of Thing (IoT) Based Wild Animal Intrusion Detection System inside the buffer zone to monitor continuously wildlife which repeatedly penetrates in the fields for crop raiding. The conflicts among Humans and animals are caused by agricultural encroachment, illegal poaching and industrial activities all together cause scarcity in the park, and dryness in the forest. The system developed which used PIR HC-SR501 sensor, WebCam, Arduino Uno, Light Emitting and image processing, it was worked when it was positioned on the peak of the tower and the results was always monitored by developers, means the developed system was not automatic (Divya & Usha, 2018).

The Animal Intrusion Alert System was designed to work together with Wireless Sensor Network (WSN) and image capturing procedure for warning wild animals and notifying landowner and park rangers. The System was used to solve problems found in Agricultural fields in India. Due to deforestation and rapid growth of industrialization in forest zones, forest animals lack food and powerlessness, their habitats and move forward into farmers' fields for crop raiding. The Alert Systems used to warn and block wildlife stopping raiding crops included electric fences in which, Wheatstone bridge was developed. The watershed algorithm is used to capture the image of wildlife and make a barrier between them. The WSN used had limitations such as bandwidth, the charge and prices of nodes, deployment models into the cloud, Hardware and/or software designing limitations (P *et al.*, 2018).

The Crop Prevention and Animal Intrusion Detection System were developed. The Raspberry Pi, Radio Frequency Identification Device (RFID) and fogging machine were used to make Smart Farmland. Forest rangers got notifications holding forests zones in which wildlife are found. The system used RFID injector and LF tag is injected in the animal's kin for better detection. Whenever the wildlife crosses the passing buffer zone, the system detects it and sends messages to the authorized users and uses a fog machine by providing smoke in the area. Solar Electric fence system used to protect crops; it also provided some limitations such as power outage during weather conditions and extreme rainy seasons, loss of life (Journal & Priya, 2018).

The uniqueness of the Automatic Escaped Animal Detection and Monitoring System was to increase safety and security in the area by automating manual systems and improving the current systems, reduction of crop raiding, early warning defenseless people for vacating the route, reduction of injury, death and pain of wild animals caused by electric fence systems and finally equipment would be commanded by the system to turn on or off based on the movements sensed.

CHAPTER THREE

MATERIALS AND METHODS

3.1 Study Area

The design of an automatic buffer wall system, sensors and actuation instruments; we setup up buffer zone, which is the special area of wildlife, the development of the system should be agreed by the park rangers and general management (RDB) to test whenever the system meets all the requirements in accordance with their values and regulations

3.2 Project Design

The project design is a framework that consists of procedures and methods that researchers use in order to achieve the desirable project goals. In this project, we made use of Agile methodology as a project design approach.

The designing and prototyping processes of agile methods include different phases grouped into at least three phases: namely the phase of conceptual creation and requirements analysis, system design and system development and lastly system testing and performance validation (Nasehi, 2013).

The operations of an automatic buffer wall are understandable through the phase of creation, then the existing practices and availability of tools used for analysis. The validation phase used to test the performance; it involves computation of the design and system refinement processes. The project refinement is necessary and key judgment that form the beginning of a successful project and ensure the model would function successfully based on the requirements (Decisions & Refinement, 2013). This development has been repeated until the performance measure was fulfilled. The design needs to be implemented and evaluated.

The Arduino NANO board as our Microcontroller was used to develop the prototype which requires all parts and processes to implement the concept based on the design. The board also keeps and houses the codes. Indoor Ultrasonic sensor was used for detecting the motion of forest animals approaching the buffer wall and outdoor PIR sensor was used to detect and monitor intruders wanted to enter into the park illegally; LEDs were used for signaling and making block, GSM SIM900 Module was used for connectivity of the designing blocks at the buffer wall and to send messages related to wild animals and intruders approaching the buffer

wall, the Buzzer was used on the system/gate to give an alert to security guards and park rangers in order to check message displayed on the LCD such as in and out alert messages and the speed wild animal was using, the Global Positioning System (GPS NEO 6M) was used to give the coordination of the wildlife approaching the wall and finally, the SIREN sound alarm and speaker were used to warn intruders and wildlife respectively.

3.2.1 Agile Methodology



Figure 5: Agile Methodology

Agile System Development was chosen because it helped to make a continuous improvement and to get high quality outcomes. It was used to maximize customers' needs (Sharma *et al.*, 2012). The most popular type of agile methodology used to develop this project was Scrum model; it helped us to break the project into phases with a fixed period of time and developers could productively and creatively deliver the highest outcomes with higher performance.

3.3 Wild Animals Detection Devices

The Passive Infrared (PIR) sensor and Ultrasonic sensors are used to sense the motion of presence of wildlife and intruders and interfere with hearing respectively (Yusman *et al.*, 2018). Wild animal detection and monitoring systems have an important functionality in terms of

safety, detection, control, and warning operations while wild animals get out of the forest for crop raiding. Detection devices were chosen based on the precise parameters such as application, data transmission, speed, charge and maintenance. Due to the increases of wildlife in the VNP such around 1 063 mountain gorillas (Numbers, 2019) and illegal poaching activities and unethical electric fencing, it requires higher technologies to protect buffer zone and reduce human-animal conflicts happening on the edges of the forest .

3.4 Classification of Warning Devices

The Ultrasonic and PIR sensors after detecting the movements of presence of wildlife and intruders, Buzzer , LEDs, speaker and SIREN Sound alarm work together in order to produce alarms and warnings to the wild animals (Rani, 2017) and intruders. This automatic buffer wall system, the warning devices were unified to detect the motion of wild animals. The Passive Infrared (PIR) sensors are in use for detection scenarios.

3.4.1 Movement Detection Sensors

The cheapest and best choice sensors are PIR sensors which have detection components characterized by a large lens range; they play an important function in current industries over the world for the purpose of movement detection (Ada, 2020). In this study, PIR sensor detected the moving intruders approaching the buffer wall coming from the community while the Ultrasonic sensor detected wild animals approaching the buffer wall, the speed and the distance it used. Both the Ultrasonic sensor and the PIR systems are jointly connected with a microcontroller that is installed in an organized box along the buffer wall lines. The Arduino NANO (microcontroller) generates signal controls found on the detection of the presence of wildlife and notify that there are wild animals attempting to go out of the forest.

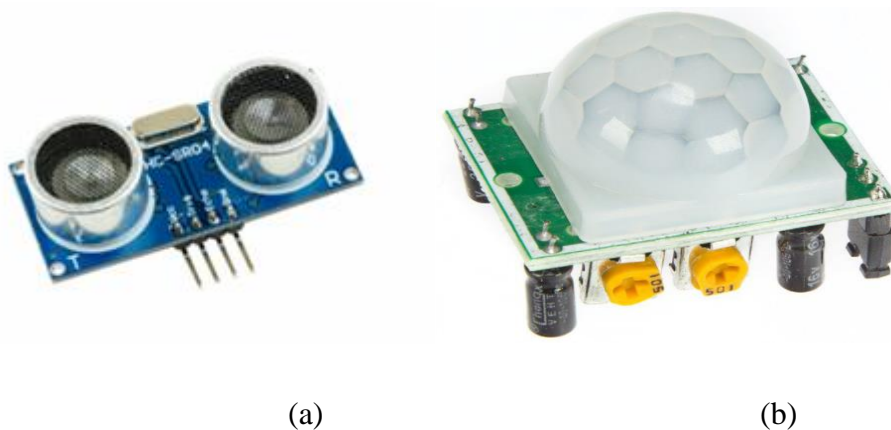

Figure 6: (a) Ultrasonic Sensor and (b) PIR Sensor

Advantages of Ultrasonic and PIR sensors

Table 2: Advantages of ultrasonic and PIR sensors

Specifications	Ultrasonic Sensor	PIR Sensor
Detection process	It is always and has the ability of detecting moving objects even in the darkness.	It is the detection motion sensor that works daily and/or in darkness
Power consumption	It has a wide range power supply of: 3.0V and 5.5V	It consumes low energy compared to other sensors: 0.8 to 1.0 watts
Installation	Very simple to connect and integrate the sensor with other components such as Arduino NANO	Very simple to connect and integrate the sensor with other components such as Arduino NANO
Scalability	Developers could increase the number of sensors to sense motions in different directions	Developers could increase the number of sensors to sense motions in different directions

3.4.2 Light Emitting Diodes (LEDs)

The LEDs components are generally used to warn everything in movements with such kind of safety. LEDs are composed of colors such as Red, Green, Blue, and Yellow. The Lights at Buffer wall which appears in red color only will flash whenever the wild animal is sensed in the buffer area targeting to get out of the forest. At the buffer wall, there will be a block of LEDs accompanied by the buzzer in order to give dynamic visual warning to the wild animals. Red LEDs will turn on whenever wild is still sensed, otherwise LEDs will be off. LEDs used when designing this project consume low energy, they will live a long time and they are directional (Singh, 2014).



Figure 7: Block of LEDs

3.4.3 Buzzer

The Buzzer component was used as the audible alarm warning equipment to produce a buzzing sound, it has two pins used to exchange audio models into sound signals and it operates with 5V DC. In this project, the buzzer would be used to warn the public living nearby the edges of the VNP Park for enabling them to evacuate and to notify the local authorities in charge of forest to quickly act and take necessary actions. It is necessarily used to notify wild animals approaching buffer walls, park rangers, and people around edges of the park (Datta *et al.*, 2016). The buzzer's alarm is activated whenever the LEDs are on since an object is sensed, otherwise it is still off. The buzzer device is used to add voice sound and beeps to the system.



Figure 8: Buzzer device

3.4.4 Siren Sound Alarm

SIREN alarms are mechanical and/or electronic components used to capture the attentions of human-beings and alert them to better react on the right urgency circumstances (Hansson, 2018). The SIREN would be used to report the Safety and notify farmers neighboring to the park and park officials that there are intruders approaching the buffer wall attempting to get inside of the park.



Figure 9: SIREN Alarm device

3.4.5 Speaker

The speaker used to play the recorded voice of a lion in order to warn wild animals approaching the buffer wall. The device has the space in which you inserted the memory card that stored the analog voice. The speaker is always in play music mode by means to be on all the time (Portable Bluetooth ® Speaker Thank You).



Figure 10: Speaker

3.4.6 Liquid Crystal Displays (LCD)

The 16x2 LCD module consists of two rows where each row can only print 16 characters. According to the Automatic buffer wall system, the information to be displayed on LCD would be messages saying that “The IN-ALERT message that includes the distance and the speed the wild animal is using by approaching the buffer wall, on the other hand, it includes the OUT-ALERT message to notify an intruder’s attempt”, whereby the message will automatically be sent to park rangers. The basic information would be displayed on the screen including time to which wildlife getting out the buffer zone, location and message sent to all people in charge of the VNP.

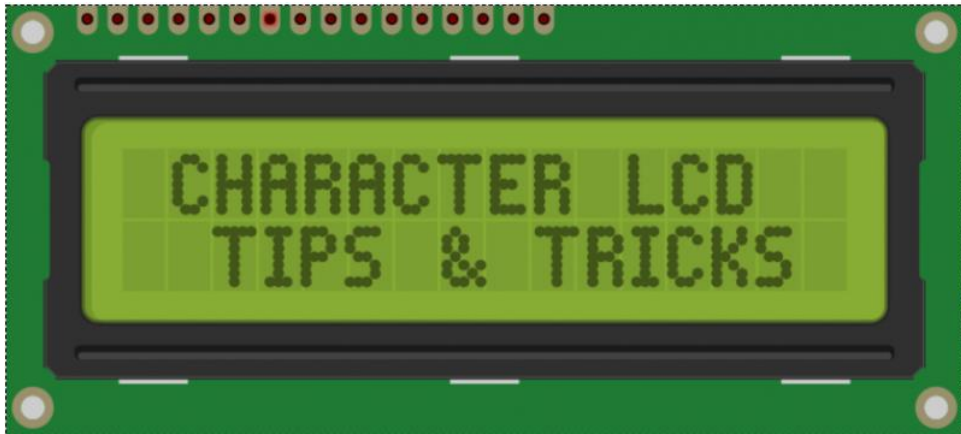

Figure 11: LCD Display

3.4.7 Potentiometer

Potentiometers are electronically used to control and to adjust the contrast and brightness of Liquid Crystal Display (LCD). The visibility of texts and messages displayed on the LCD are regulated with the presence of a Potentiometer. It is used as an interface between Arduino board and LCD (Dallas Semiconductor).

3.4.8 GSM SIM900 Module

The Global System for Mobile Communication (GSM) SIM900 Module used in this Automatic Escaped Animal Detection and Monitoring project. The GSM SIM900 chip operates between 4.5V to 12V and it comes with a high electricity and accuracy. It uses a Universal Asynchronous Receiver Transmitter (UART) protocol to communicate with the Arduino NANO via an antenna for message, voice, or data communication. It accepts the baud rate starting from 1 200bps to 115 200bps. It uses software Serial such as D8 (Rx) and D7 (Tx) (Manual, 2011), to talk to the shield. It is a notification device that accepts serial data and broadcasts to the specified park officials the text SMS. It has the ability of continuously transmitting SMS to mobile phones remotely. The developed system would contain the SIM card coupled with enough balance for working a long time (Datta *et al.*, 2016).

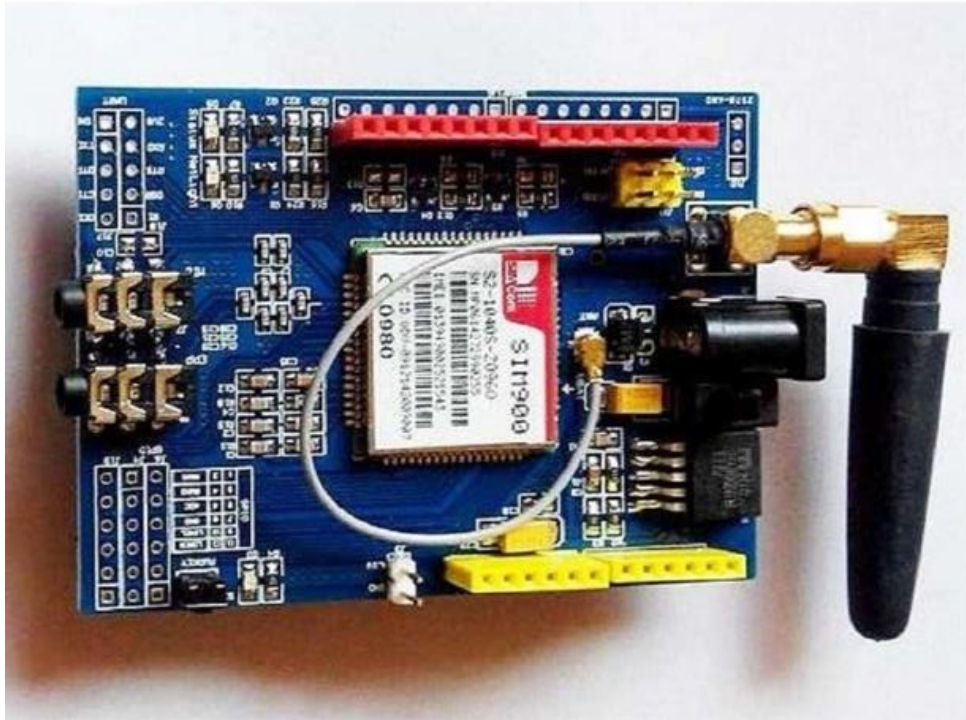

Figure 12: GSM SIM900 Module

GSM SIM900 Module is characterized by the following features such as:

- (i) High quality and durable products;
- (ii) Sending and receiving text messages, and calling and receiving voices;
- (iii) It could support any type of GSM Frequency bands used in the majority countries all over the World: 850/900/1800/1900 MHz; MTN Rwanda, TIGO-Airtel Rwanda, Vodacom and Halotel Tanzania. Specifically, SIM900A works on frequencies 900/1800 MHz;
- (iv) SIM Card owner;
- (v) Power is ranged in between 4.5V to 12V;
- (vi) Hotness temperature ranged in from negative 20°C to positive 55°C;
- (vii) Built in LED and TCP/IP protocols;
- (viii) Baud rate ranged between 1200bps to 115200bps, and more.

3.4.9 Relay

The switching components such as relays are used to open and close contacts the circuit. In this automatic buffer system, relays manage low voltage signals by means, the power of the Arduino NANO does not supply all devices connected to it such as speakers. Relays refresh the signal coming in from the 12V supplier and transmitting it on the speaker.

The speaker has two buttons such as play and pause. The two wires of play and pause buttons were inserted in the relay which has three outputs such as Normally Open (NO), Common (COM) and Normally Close (NC). Whenever the Arduino NANO does not send a signal, the relay would be in NC, otherwise the NANO sent the signal, the relay would wire the two wires NO and NC in less than one second and automatically play the voice of lion.



Figure 13: Relay

3.4.10 Global Positioning System (GPS NEO 6M)

The GPS NEO 6M is the device used to provide the position, time and speed information of moving objects. GPS together with Ultrasonic sensors were exactly and accurately recognized locations of each wild animal approaching the buffer wall by measuring the distance from the wildlife's habitats and providing the exact coordination. GPS NEO 6M consists of twenty-four satellites orbiting the Earth at twelve thousands miles in altitude which permit the signal to cover the greatest region; such signal is identified with the unique code by the receiver (Doberstein, 2012). The park rangers would be able to capture locations where to meet such wildlife getting out of the park and cross-pass the buffer wall as well as latitude and longitude.

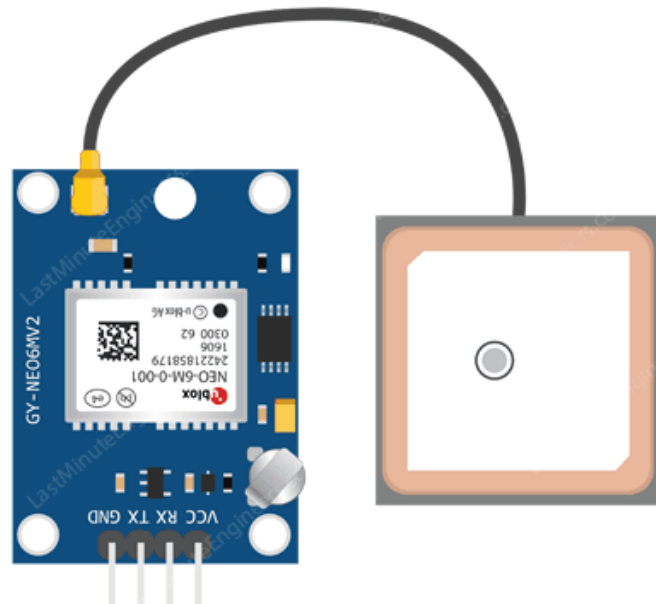

Figure 14: GPS NEO 6M

3.5 Microcontrollers

3.5.1 Arduino NANO

As long as wildlife trips monitoring is increased worldwide, the buffer wall also requires management. All the Safety and efficient and skillful methods concerning the Automatic buffer wall system could guarantee the operational management. To monitor all the mentioned uses of an automatic buffer wall and its status, the microcontroller Arduino NANO was used at the buffer wall with LEDs for flashing, Buzzer, SIREN, speaker, Ultrasonic and PIR sensor to warn and alert park's wildlife.

This type of Microcontroller Arduino NANO board is based on ATmega168 with twenty-four I/O pins whereby 22 pins are connected with input and output. Fourteen pins numbered from D0 to D14 are true digital I/O pins configured using `pinMode()`, `digitalWrite()` and `digitalRead()` functions.

Table 3: Characteristics of Arduino NANO

S/N	Specification	Arduino NANO
1	Digital I/O pins	22 (Six pins could be used as Pulse Width Modulation PWM)
2	Input voltage	7V to 12V
3	Clock speed	16MHz
4	Flash Memory	32
5	Analog I/O pins	8/0
6	Digital I/O PWM pins	14/6
7	Processor	ATmega328P
8	Power consumption	19mA
8	Weight	8g
9	Connection	USB

The Arduino NANO board facilitates the communication of other Microcontrollers by using UART serial communication available on Digital pin 0 (Rx) and 1 (Tx). The Arduino NANO has a simpler design with low cost and requires a low user-friendly programmable system. To program it, we used an analog and digital pins joined together with logical applications using C programming languages where inputs at sensing part are taken by Ultrasonic and PIR sensors, and produces outputs at actuation part by block of LEDs, LCD display and the buzzer, SIREN and speaker, the GSM SIM900 Module to send messages to all forest officials (Uno & Front, 2010). We selected Arduino NANO Microcontroller to develop an Automatic Buffer wall system, for the above-mentioned reasons.

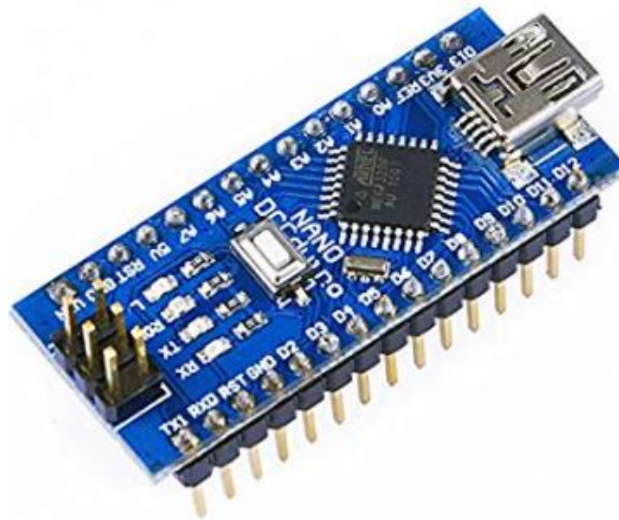
**Figure 15: Arduino NANO**

3.5.2 Advantages of Arduino NANO

- (i) To allow the connection of many devices (sensors) and their functionalities;
- (ii) To allow the scalability of the system;
- (iii) To allow data storage capacity;
- (iv) To be used to make public online information meant by remote monitoring;
- (v) Moreover, of its size, Arduino NANO executes C/C++ codes according to the received signals from the Ultrasonic and PIR sensors and it sends outputs to the LEDs, LCD, Buzzer;
- (vi) Arduino NANO was developed for fail and safe operations;
- (vii) Arduino NANO board, the stand-alone automatic buffer wall system could be developed, whereby the system would be powered by hybrid power either DC power and by using chargeable batteries used as power backup and/or grid powers (AC-DC inverters).

3.5.3 Errors Correction Methods and System Maintenance

An Automatic buffer wall system must be analyzed, repaired, and corrected on a daily basis to raise its efficiency. The developed system would work 24/7 which means to prevent its failing, the normal and regular check up to make the system for easy maintainability is required. Sensors would be checked up from middle service zones. Notification components, sensing and actuators and warning devices would be connected to be sure that the automatic buffer wall system is working properly. The developed system is fault tolerance to mean the system operates only in a fixed direction. Whenever wild animals attempt to pass the buffer wall without being detected, warning and notification, means the system does not work correctly caused by the circuit and connected devices. The trained park officials would be responsible and control each buffer wall to check and to generate the report of all errors shown by the system.

3.6 Power Consumption

The automatic buffer wall system would work daily, by means the system needs power for functioning with no interruption. The power supply must have different power sources such as power grid and an additional source of energy such as chargeable batteries. They should have enough power for permanently ensuring operations of the system and they would be used as

the backup energy due to power grid fluctuations and interruptions which may delay the system for responding.

The system would be deployed in a jungle distanced by 3km in width. The use of chargeable batteries would be the benefits not only of the Automatic buffer wall system but also the environment, there would be zero pollution during the operations of the system, and it could be used in remote zones. The additional use of batteries is cheaper compared to other sources of energy; easy to install and to maintain; reliability and efficiency are flawless.

3.7 Data Transmission

Newly, the world has turned into a village. Internet users communicate with each other from everywhere all over the World. The information detected by the system devices at the buffer wall to be shared with park officials is controlled, managed, stored, processed, and retrieved in a computer and could be accessed through both wired and/or wireless data transmission to reach the intended destination.

3.7.1 Fiber Optic Cables (FOC)

The system would be installed at the buffer wall to sense the movements of wild animals. The position, the time break among the information sensed and processed, operations, installation cost, the highest data transmitted, and maintenance of the system would be an issue factor; so that Fiber Optic Cable (FOC) medium is needed. In addition, the sensed wild animal information must be transmitted to all park officials. Fiber Optic Cable is the best and best medium used in data transmission compared to other media such as Twisted Pair and Copper cables because of its higher data transmission rate, low cost, and simple installation. Fiber Optic Cable could not be affected by the hazards of the weather environment. In addition, the automatic buffer wall system would be installed in the jungle and remote zones where the Radio network could be used as an alternative. Fiber Optic Cable would be used to monitor large zones for the benefits of decreasing the compensation to people and properties. Among the two types of FOC, Single-Mode Fiber Optic cable is favored among the detection zones of signals to twelve Single Mode Fiber twenty-four Single Mode Fiber General Installation standards (Mishra, 2014; Gemelli *et al.*, 2010).

3.7.2 Wireless Communications (Wi-Fi) Technology

The sensed data concerning wild animals would be transmitted to all park officials remotely. To do so, Wireless Fidelity Technology would be used. The use of Wireless communication components which are used in different domains such as to monitor the moving objects, electronic-Health, Electronic-learning, Electronic-transportation and more would keep track on to be developed in huge numbers and mobility. Wi-Fi technology is basically used on the Internet of Things (IoT) which is connected wirelessly and adds extra communication to our daily life. Whenever wild animal pass by the buffer zone, the system could be triggered automatically whereby wild animals would be detected and monitored and be active. Nowadays, the Wi-Fi capabilities are built in Microcontroller boards for easy functioning (Zeng *et al.*, 2013).

3.8 System Requirements

The development and designing of the system, we have to consider and meet the next requirements in order to make sure that the designed project would react to the need of RDB and Local farmers who live at the edges of the park. Those needs include:

- (i) To design the prototype which should sense the approaching wild animal and intruders to the buffer wall, therefore notifies park rangers;
- (ii) Warning devices such as Buzzer, SIREN and the speaker would be activated whenever the wild animals and intruders are in the buffer zone and are attempting to approaching the buffer wall;
- (iii) The block of LEDs would be on as the movements of wild animals are detected in the buffer zones;
- (iv) Whenever wild animal or intruder is approaching the buffer wall; the IN Alert or OUT Alert Messages (SMS) would be sent to the park rangers whose phone numbers are registered in the system.

3.9 Functional and Non-Functional Requirements

The automatic buffer wall system was developed based on functional and non-functional requirements whereby functional requirements described functions that a buffer wall system

should do and non-functional requirements described how it works, it may include system reliability, low cost, and low maintenance (Chung *et al.*, 2012; Vetter, 2017).

Both functional and non-functional requirements were responded in order to validate the designed automatic buffer wall.

3.9.1 Functional Requirements

- (i) The designed system should automatically sense approaching wild animal from its habitats, the distance, calculate the speed of the wild animal and the coordinates such as latitude and longitude;
- (ii) The system should send alert messages to park rangers to notify them a hazardous happening in the buffer zone;
- (iii) The system should activate the buzzer when there is a movement of either wild animal or intruder;
- (iv) The system should automatically activate the block of LEDs, SIREN and speaker whenever both wild animals and intruders approach the buffer wall.

3.9.2 Non-Functional Requirements

Non-functional requirements of our system include performance, economic and operating requirements.

- (i) The system should work all the time;
- (ii) The system should be able to control the movements of wild animal and intruders approaching the buffer wall;
- (iii) The system would be economically efficient;
- (iv) The system should involve low maintenance.

3.10 Project Area

To design and to develop this automatic buffer wall system, we took the case study of the Volcanoes National Park (VNP) located in Northern-Western Provinces, Rwanda. In the Republic of Rwanda, there are a lot of National Parks such as Akagera National Park (ANP), Nyungwe National Park and Volcanoes National Park (VNP); they have used electric fences at ANP which are ethically bad to wild animals. The use of the developed system had taken an

innovative system closer to the Volcanoes National Park (VNP). The VNP covers four administrative Districts such as Musanze, Burera, Nyabihu and Rubavu and twelve Sectors bordering Volcanoes National Park as indicated by the Fig. 16.

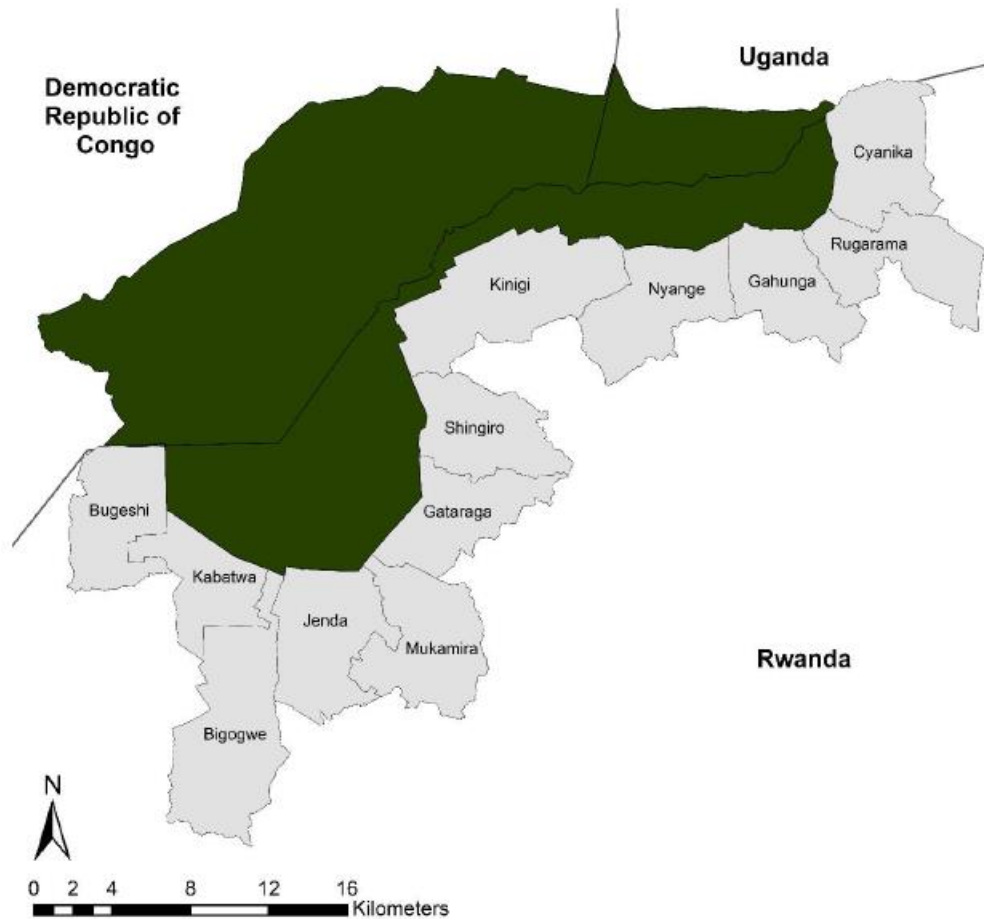

Figure 16: VNP (Park, 2019)

3.11 System Implementation

Based on the functional and non-functional requirements (discussed in Chapter four), we have divided our system into two parts such as:

- (i) Sensing part;
- (ii) Actuation part.

3.11.1 Sensing Part

Sensing part would help the system to receive inputs by allowing it to read the surrounding environment. The motion of wild animals approaching the buffer wall would be done accurately.

- (i) PIR sensor would detect the presence of intruders moving around the buffer zone;
- (ii) Ultrasonic sensor would sense wild animals approaching the buffer wall;
- (iii) Sensors send signals to the actuators part to be activated.

3.11.2 Actuation Part

The Actuation part would help the system to act in its environment. The system would be activated at the actuation part by a block of LEDs switched on, buzzer and SIREN's alarm and the speaker's voice of lion sounds. The Microcontroller Arduino NANO would be used as the heart of the above listed parts; Arduino NANO would be used to configure both parts together.

3.11.3 Selecting Sensors

Developers of systems would like to acquire and use multiple sensor devices which collect different information including wild animal motions which were the target to be sensed and make a judgment of the movement in the buffer zone, notification information, and warning information. This increases the biggest amount of information from different resources.

The methodology of selecting sensors used in this system had been done with attention based especially on the lower cost sensors and durable sensors which would perform the expected functions. Selecting sensors used in this system, we focused on the sensors' data sheets and also the type of sensor, its correctness and measurement capacity (Hirayama, 2016).

For visible light, the wavelength is similar to the wavelength of a bulb. The light can be seen by the eye of human-being. Moreover, to make covers using plastic and/or metal packaging have been compared such that using plastic, designers get a lot of benefits: low cost, high results/outputs power, consistency, and reliability.

3.11.4 Arduino Integrated Development Environment (IDE)

Arduino Integrated Development Environment (IDE) is an official setup launched by arduino.cc mostly used for editing codes, compiling, uploading written codes in the Arduino Sensors. It is open-source software downloaded freely to the internet and all Arduino Modules are friendly with it. It contains a Microcontroller on the board which presents the relationships between sensors and actuators in their environment (Fezari & Dahoud, 2018).

The major functions of Arduino IDE:

- (i) Sketch. Sketch, it is the unit of codes uploaded to Arduino and run-on Arduino board connected to PC via USB;
- (ii) Setup and loop. It is a function used to initialize values. When the sketch starts, the setup () function is called. Whereas loop () function runs codes repeatedly until it reaches its conditions.

3.11.5 Fritzing

Fritzing is massive open-source software used for developers to design prototypes and electronic circuits to solve specific problems such as automatic detection and monitoring of moving wild animals. This tool permits designers to arrange and organize their hardware devices in order to get the intended result by connecting sensing parts with actuation parts together. It is used to document the entire product (Knörig & Cohen, 2009).

3.11.6 EasyEda

It is an online dominant schematic tool used to design and simulate online electronic circuits with zero-installation. Easyeda would help the developers to import the designed circuits in either portable document format (pdf) or image. It is a user friendly tool such that developers should work anywhere at any time on any devices and make online access and sharing of Printed Circuit Board (PCB) (Editor *et al.*, 2020).

3.12 System Testing

The buffer wall, it was mechanically used as the barrier in the buffer zone in Volcanoes National Park (VNP). It was a fixed block of stones built and it functioned linearly. Once the design and implementation of the automatic buffer wall system was accomplished, each component used to develop this project in each unit was tested and evaluated to check its assessment based on the system requirements. Unit testing was tested before mixing to the other modules and then the system unit was tested. The EasyEda tool was used to simulate the system, the Microcontroller with Block of LEDs, Buzzer, SIREN, Speaker, GPS NEO 6M and properties of Ultrasonic and PIR sensors. Sensing and actuation parts were tested such that the power and energy part.

Field-testing approach was carried out using a prototype; Appendix 5 shows the setup of the system. The main aim was to ensure the system could successfully be installed into VNP zone and functioned as expected. Ultrasonic and PIR sensors was positioned on the wall to continuously detect and monitor the movements of wild animal and intruder respectively. The study confirmed that the system, after monitoring wildlife and trespasser approaching buffer wall, it was activated and sent notification to park rangers. Figure 25 showed the notifications sent by the system.

CHAPTER FOUR

RESULTS AND DISCUSSION

4.1 Results of the System Design Process

The designed Automatic Buffer Wall Detection and Monitoring System was developed based on the technical design, standards, and security requirements in order to protect the wild animal from pass buffer zone for crop raiding. Solutions provided by different developers according to the problems shown at Buffer Wall must be the long-term system output to the VNP. The technology used for wild animal detection and monitoring must satisfy the benefits of all park users and people around it.

The Automatic Buffer Wall System in the VNP was designed and developed in order to decrease all the evil happening at the buffer wall such as crop raiding, death and injuries on both sides and infrastructures destructions. The developed system would warn wild animals approaching the buffer wall and automatically notify the park officials, farmers and people living near the edges of the park.

4.1.1 The Major Causes of Crop Raiding

To make the assessment of the main causes of crop raiding with this study, was based on Gender, Marital Status, four Sectors located in Musanze District in which respondents live, and distance in Kilometers and in meters linking the park and residential houses or farming fields. Table 4 expresses the details of every group among 52 respondents.

Table 4: Types of Respondents

Particulars	Category	Respondents	Percentage (%)
Gender	Male	35	67.3
	Female	17	32.7
Marital status	Single	27	51.9
	Married	23	44.2
	Others	2	3.9
Sector	Nyange	19	36.54
	Shingiro	10	19.23
	Kinigi	14	26.93
	Gataraga	9	17.30

Figure 17 Shows the mostly and likely crops found in the Area (VNP) that are raided by wild animals.

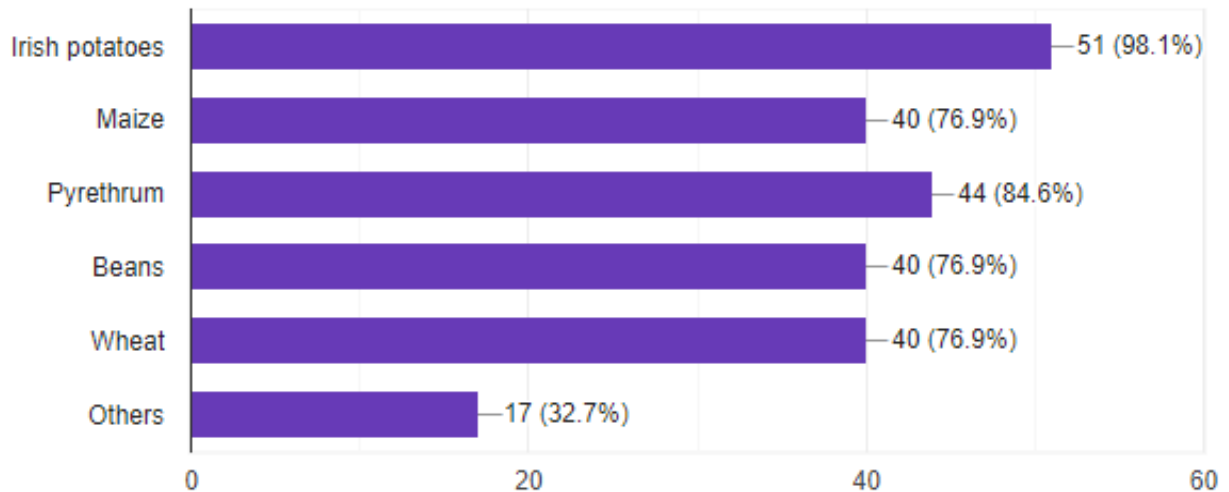

Figure 17: Type of crops found in VNP

The Fig. 17 shows the likely plants found in the region and are the mostly raided by wild animals.

The following Figs. 18 and 19, respondents explained how far (in metrics) and how people and farmers are closer to the park which leads to crop raiding, death, and injuries on both sides.

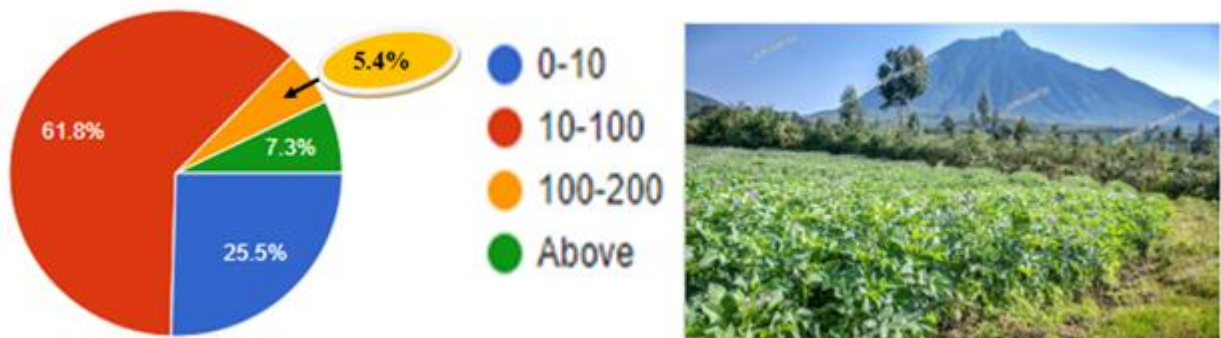

Figure 18: Distance (in metrics) between the park and farming fields

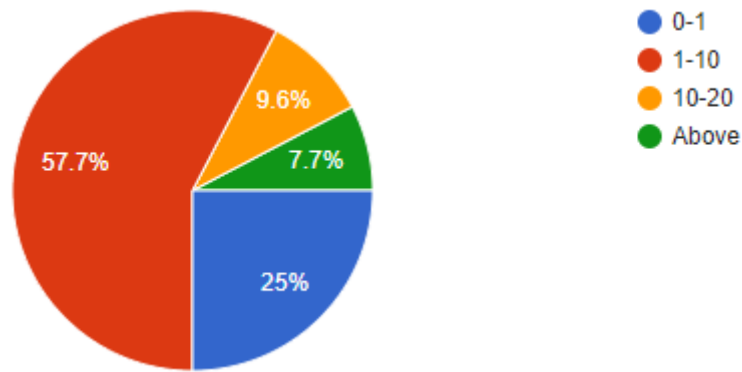

Figure 19: Distance (in metrics) from the park to the house/community

4.1.2 Existing Buffer Wall System at VNP

Volcanoes National Park VNP situated in Northern-Western Provinces in Rwanda, it is currently holding a lot of wildlife around 1 130 species and more than 350 gorillas (Uwayo *et al.*, 2020). Farmers practice agricultural activities which represent the primary income of all people around the park. The area consists of different crops which are likely by wild animals. Crop raiding mostly by Buffalos, Gorillas, Monkeys, black-fronted duiker, bushbuck, and more is the biggest issue at VNP. The farmers cannot produce and harvest their crops; wild animals are killed when they get out of the forest and directly into the fields.

Reference to the National Land use and Development Master Plan (MOE, 2020), the buffer wall was built to protect and secure the area for biodiversity and wildlife monitoring and tracking and also to reduce human-wildlife conflicts and human illegal activities on VNP. It was manually made by a fence of stones and it represents 1km distance from the external boundary of the VNP toward the community with the width of 1.5m and the height of 2m (ORTPN, 2005).

4.1.3 Challenges of Existing Buffer Wall Systems

The buffer wall was built for the management of Volcanoes National Park, to be better monitor biodiversity and reduce conflicts among human and wild animals in the area. Buffer walls were primarily used as the protection between the people and their crops from animals leaving their habitats and forests. They are used to minimize the human collisions on tourism.

However, the main challenges include:

- (i) Traditional techniques whereby farmers are organized into rotational groups and using strong torches to warn wildlife;
- (ii) The distance between the park and community is too small;
- (iii) The distance between the buffer zone and Families is also too small;
- (iv) The main crops growing in the area are most likely by wild animals;
- (v) Methods used to reduce the impact of forest animals to crop raiding show weaknesses;
- (vi) A huge number of poachers increased daily;
- (vii) Deforestation;
- (viii) There is no use of Buzzer at the buffer wall to alert wild animals approaching it;
- (ix) There is a lack of awareness of the community around the park;
- (x) Manual management of the buffer wall: this is to mean there are no LEDs, warning devices, other electrical devices, and so on.

4.1.4 Description of the Designed and Developed System

The Automatic Escaped Animals Detection and Monitoring System, is a system placed in a jungle line in the buffer zone proposed to offer safety and to reduce the conflicts between human-wildlife.

The system is detecting and monitoring moving wild animals attempting to approach the buffer wall; automatically the system is on, warning animals by using block of LEDs, Buzzer, and notify park officials that there is an animal attempts to get out of the forest.

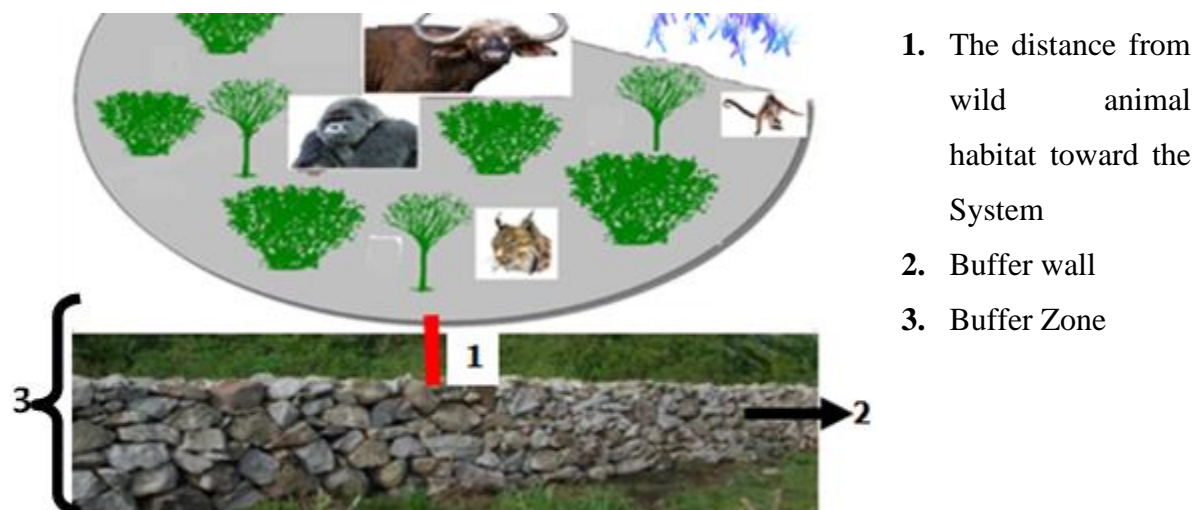

Figure 20: Proposed System

4.1.5 Design of System Block Diagram

Figure 21 characterized the operational standard of automatic buffer wall in which the coming wild animal and intruders approaching buffer zone would be detected by Ultrasonic and PIR sensors respectively, the system sends signal and notify park rangers automatically; it would also warn wildlife and trespasses with the facilitation of LED lights, Buzzer, SIREN and Speaker. The GPS NEO 6M and GSM SIM900 Module start running using commands and codes given to the Microcontroller. The buffer wall system would remain active whenever there are wild animals or intruders being detected in the zones.

4.1.6 Parameters for Systems

Fundamentally, this automatic Buffer Wall system consists of four major parts:

- (i) Sensing part;
- (ii) Transmitting part;
- (iii) Processing part;
- (iv) Controlling.

Taking into consideration when either the wild animal comes from inside the park or an intruder comes outside of the park and approaches the wall, signal would be sent to the control unit through transmission medium such as Fiber Optics or coaxial cable. Then the system would be activated until there would be no wild animals or intruders in the buffer zone, therefore, warning signals should be in silence.

We have used a huge amount of components such as sensors and actuators to achieve our design such as an Automatic Escaped Animal Detection and Monitoring System that we have designed and developed in order to reduce crop raiding, accidents and injuries and infrastructures damage in the VNP.

Parameters used at the sensing part in order to design the prototype are the Ultrasonic sensor HC-SR04 and PIR sensor which together sense the presence of wild animals and intruders approaching the buffer wall respectively. It senses the movement of wild animals, the distance and calculates the speed on which the wild is using. After the distance and speed has been sensed Ultrasonic will send a signal to the actuators to trigger the LEDs to be on. It would also

communicate and do Real-time continuous updates on the LCD to display the distance and the speed, and the GPS NEO 6M would be used for coordinating the location of wild animals.

This process enables park rangers, RDB and local communities to maintain the movements and coordination of wildlife.

When the actuators are informed that there is a wild animal or intruder approaching, they will activate the Automatic buffer; the block of LEDs will be on, the buzzer, SIREN and speaker will ring to alert the officer who controls the system to notice that nearby the wild animal is approaching the Buffer wall.

The GSM SIM900 module was used for the communication between the Automatic Buffer Wall and the wall station. This module is helping to communicate the distance, speed, and coordinates of wild animals. This is to help park officials to know where they would capture wild animal.

4.1.7 Circuit Diagram Design

The following schematic diagram represents the connectivity of every component of the system designed at the control unit.

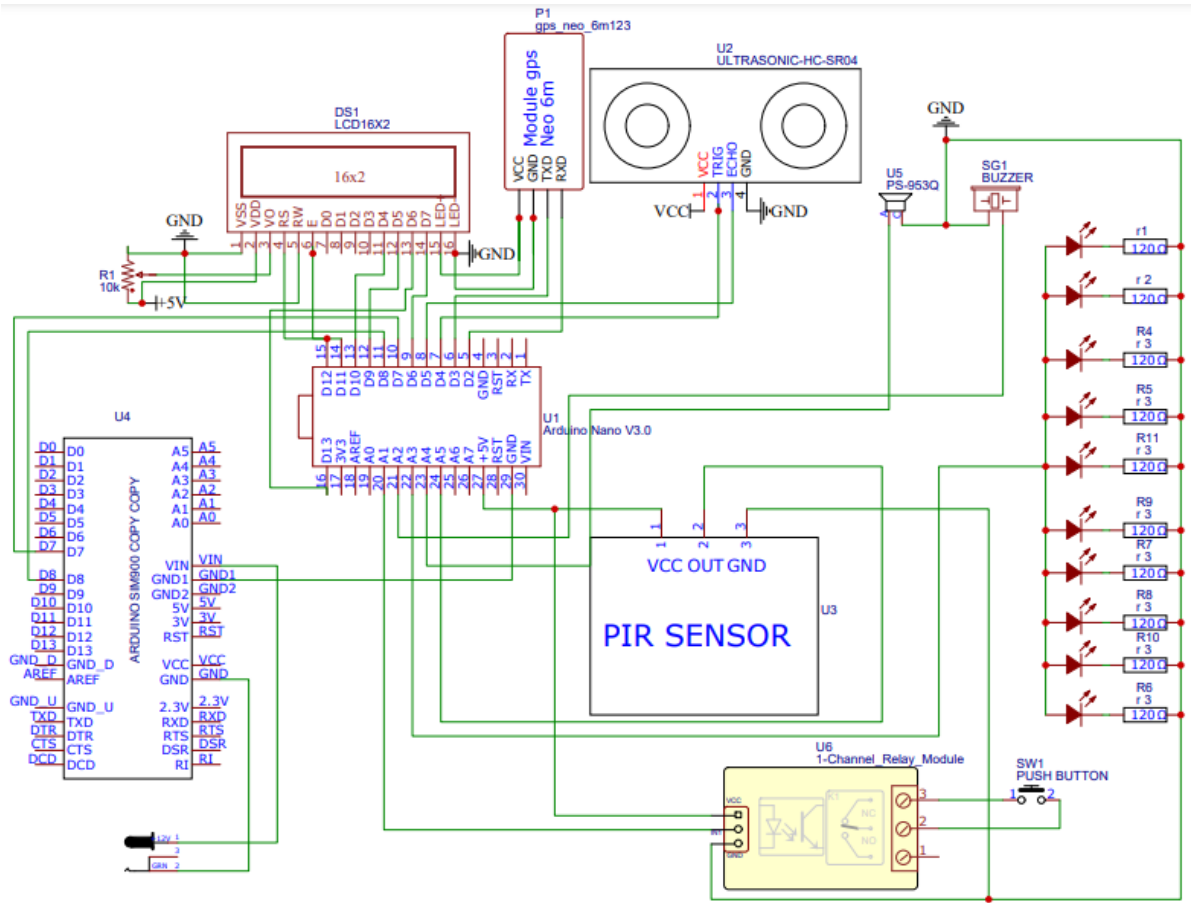

Figure 21: The schematic diagram for the automatic buffer system

4.1.8 Block Diagram Architecture

The next block diagram was the vital method used to develop and describe Hardware components and it represented the workflows and its functions, problems, and designs.

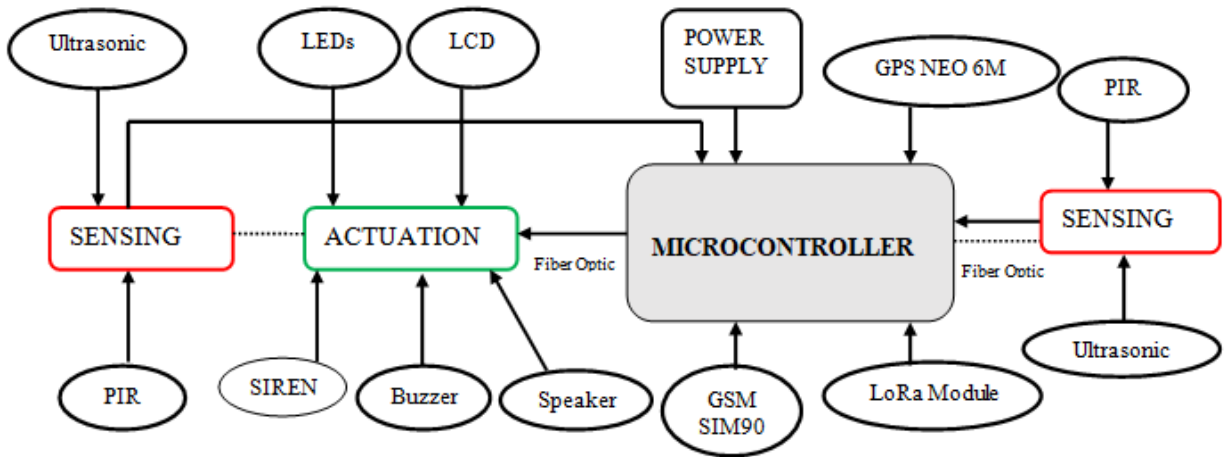

Figure 22: The building block of the system architecture design

4.1.9 Data Flow Diagram

This diagram below represents the flow of events of inputs and output information.

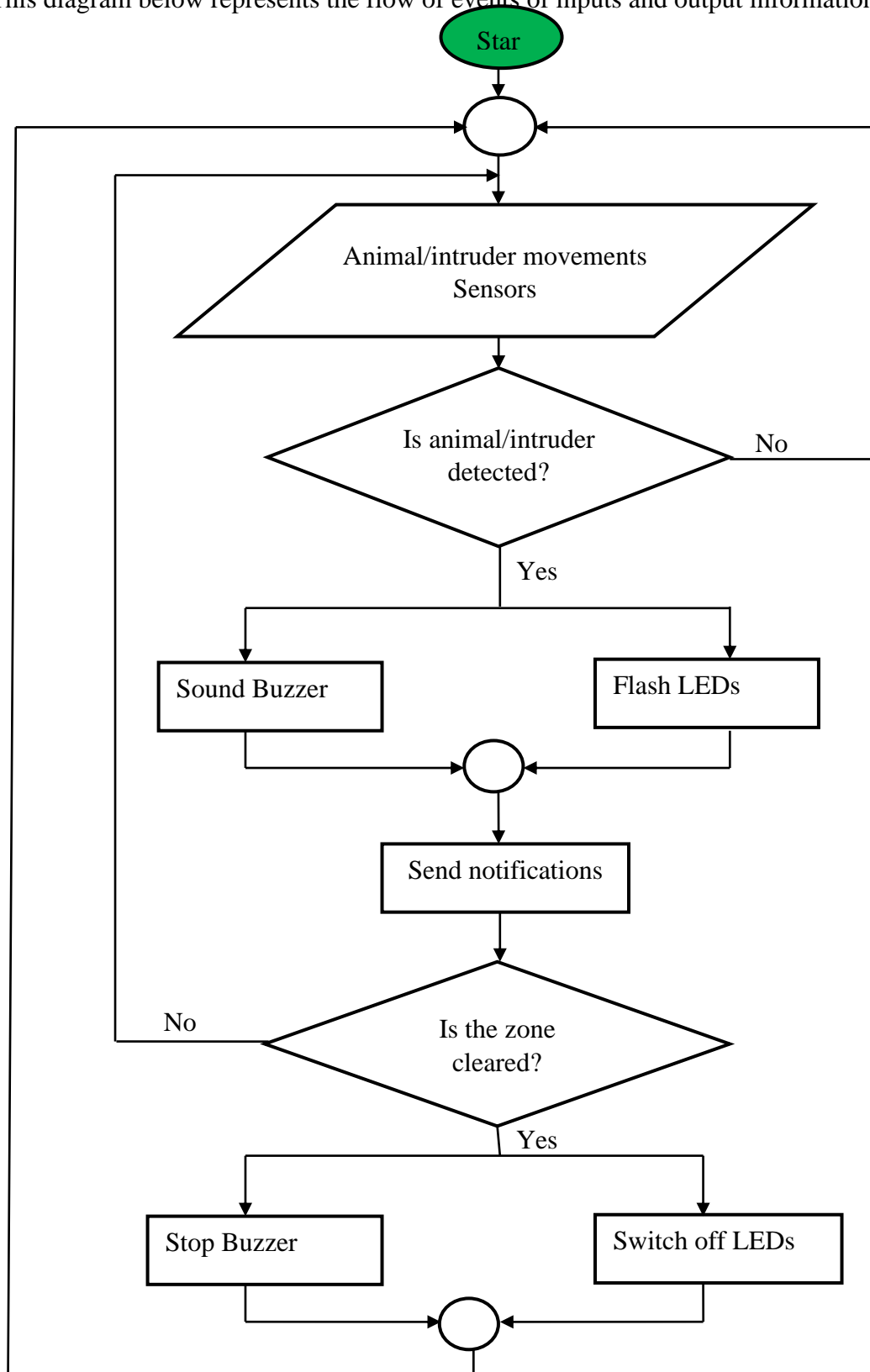

Figure 23: Data flow diagram of events and controls for the system designed

4.1.10 Choosing Sensing Components

We used different techniques to implement the system in order to differentiate existing buffer wall system at VNP which shown that there was no automatic system at buffer zone; that's why we designed and developed an automatic buffer wall system using Ultrasonic sensor for sensing the distance and Speed of the wild animal to make active the actuators and PIR sensor to sense the movement of intruder approaching the buffer wall.

(i) Ultrasonic sensor

In this prototype design, Ultrasonic sensors work in distributing out a sound wave at a frequency higher than the range of human hearing. It decides the distance to a target by measuring time lapses between the sending and receiving of the ultrasonic pulse. It allows accurate detecting and monitoring the speed of wild animals permanently whenever it approaches the buffer wall.

(ii) PIR Sensor

The PIR sensor was used in this system to detect and monitor an intruder approaching the buffer wall outside of the park. It plays an vital purpose in Modern and Technological industries across the entire world for the purpose of movement detection (Ada, 2020).

(iii) Arduino NANO

The Arduino NANO is a microcontroller board based on the Atmega328. It is the brain and the core part of this prototype developed in which all codes from PIR sensor, Ultrasonic sensor, SIREN, Speaker, LCD, LEDs, and Buzzer are configured and permit the communication among the sensing part and the actuation.

(iv) Wi-Fi

The Wireless Fidelity (Wi-Fi) is the technology that allows the communication between the Automatic Buffer Wall System and the Cell phones which receive alert messages specifying whether the wild animal or an intruder is approaching the buffer wall. When the wild animal comes close to the buffer wall throughout one node, the alert message would be sent and specified the distance, speed, and coordinates in which the wild animal is using.

4.1.11 Sensors and Actuators Connections

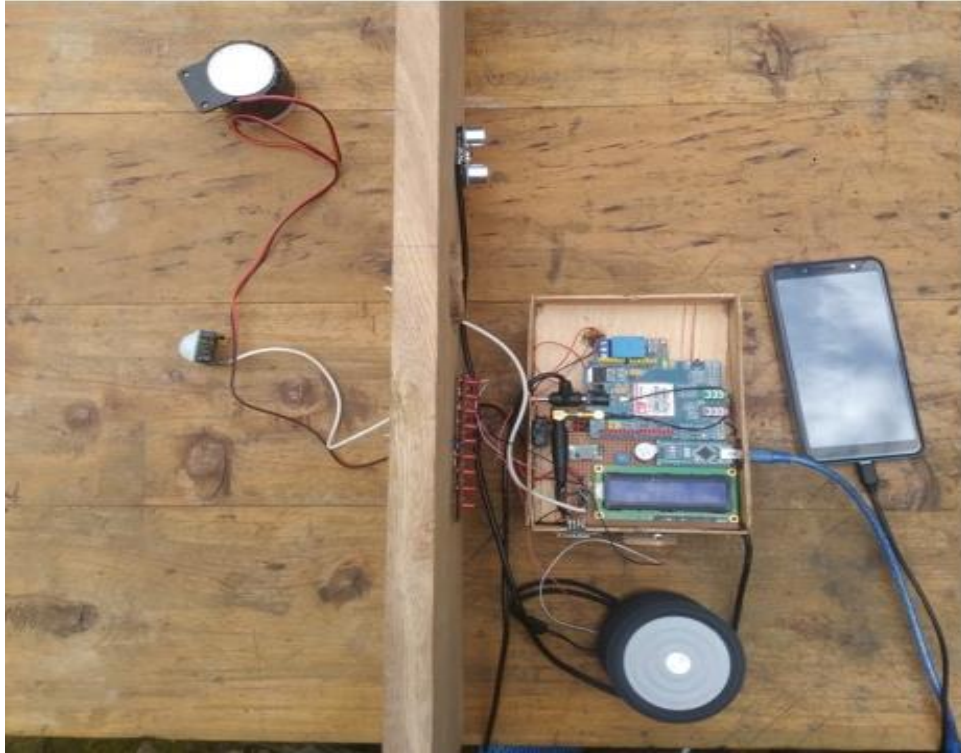

Figure 24: Connection of sensors and actuators

4.1.12 System Testing and System Validation

By the end of the designing and development of the Automatic Escaped Animal Detection and Monitoring System, each Unit was put to the test to assess the manner it carried out and its fulfillments based on the system requirements. The internal working of the system was tested; by means of that EasyEda tool was used to simulate the Buzzer, SIREN, Speaker, and LEDs. Unit and Integration testing were used for all built blocks of the design such as sensing part, actuation part and energy part.

Unit testing was done automatically during the system development to make sure that this section met all it was required. This unit test confirmed that the smallest part of the Automatic buffer wall could work accurately when it was isolated from other parts of the system.

The proposed system was tested in front of HOBUKA Ltd, a company interested in bringing conservation solutions, and they strongly approved and were interested in the system's operation. It was also tested in Musanze District, Nyange Sector (Appendix 5), where an agronomist in charge of agricultural activities was present, and stated that if the prototype is

converted into a finished product and deployed, the people and crops around VNP will be safe and secured.

4.1.13 System Performance Test

The Automatic Escaped Animal Detection and Monitoring system was tested to make available functionalities at Buffer wall successfully. Every part of components of the system works as per design; the wild animal was detected, the distance and speed were calculated, the signal was sent to the actuator to make active the buffer wall, LEDs, Speaker, SIREN, and the buzzer. The alert messages such as IN ALERT! At a distance=6cm speed of 495.00cm/s please check fast Latitude: -1.488586 and Longitude: 29.63351 together were sent to the park officials and notified them that there was a wild animal approaching the buffer wall. On the other hand, the alert message such as OUT ALERT! Check surroundings, and the park officials notified them that there was an intruder approaching the buffer wall. The following Table 5 shows the results such as distance measured in centimeters; Ultrasonic sensor used to develop this system sent data in centimeters (Appendix 1), speed, Latitude and longitude.

Table 5: Data sensed and sent to notify park officials

Distance (cm)	Speed (cm/s)	Latitude	Longitude
6	495.00	-1.488586	29.63351
3	1187.00	-1.488591	29.63394
3	1058.00	-1.488558	29.63399

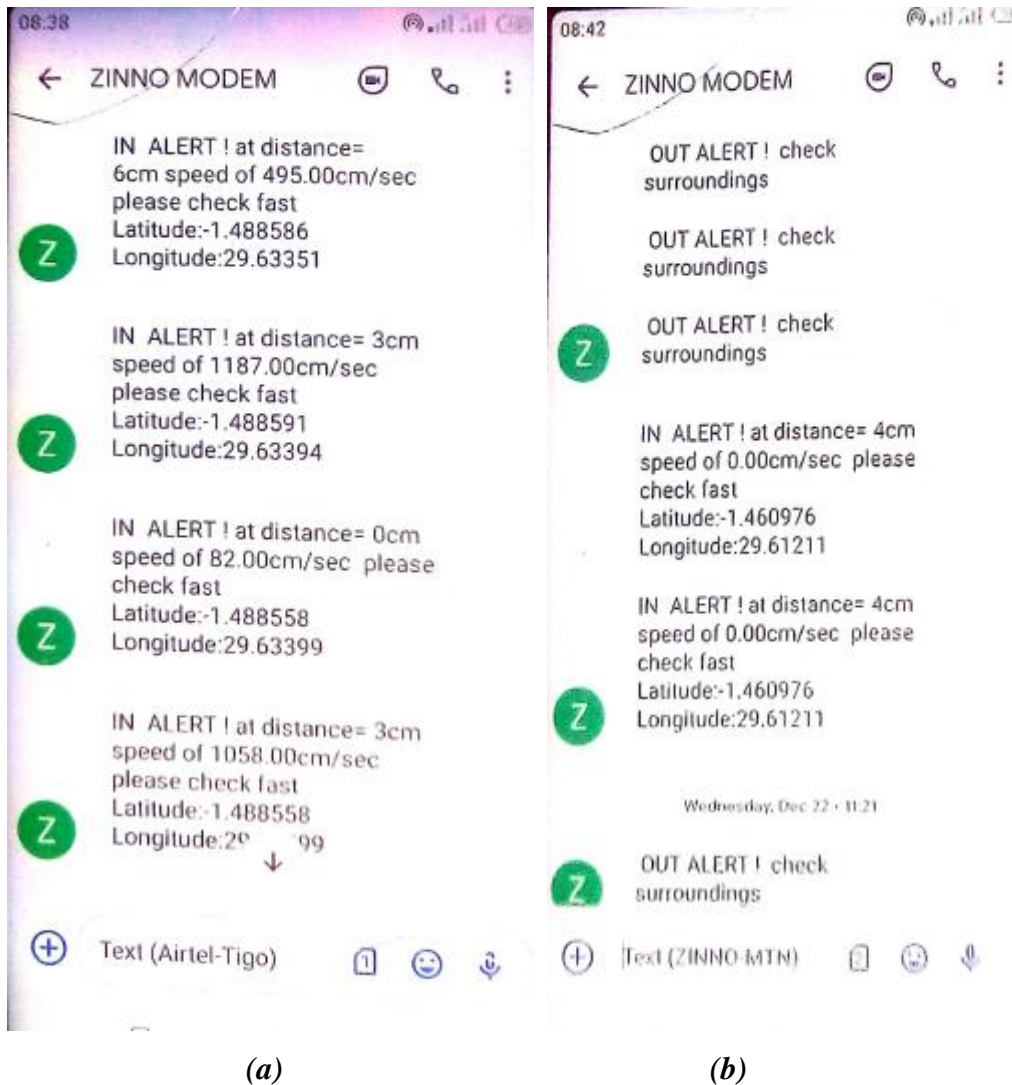

Figure 25: SMS Notifications: (a) IN ALERT! And (b) OUT ALERT!

4.2 Discussion

The tests carried out during the design and development of this system confirmed that both wild animals and intruders approaching the buffer wall could be automatically detected and monitored and the reduction of their effects on the farmers. The distance, the speed and coordinates of wild animals were monitored with the help of Ultrasonic sensor which determines the distance to a target by measuring time lapses between the sending and receiving of the ultrasonic pulse together with the GPS NEO 6M; an intruder approaching the buffer wall was also monitored by using PIR Sensor. The IN ALERT! And OUT ALERT! Messages were sent to park officials to notify them of a hazard situation. Figure 25 proves texts messages sent to them. In each case such as IN ALERT and OUT ALERT, Park rangers of VNP, safety could be granted with no delay. The alarm alerts produced by the buzzer, SIREN and speaker showed

to be very quickly the way of alerting the people around the edges of the park of the danger. Consequently, the defenseless people can be alerted before a wild animal is getting out of the park and vacate the route towards their home to save their lives. The tests done showed the reduction of wildlife's pain.

4.3 Limitations

The six months period of time assigned for the development of this project was not enough for data collection, investigation, development and testing in the study area.

During the project proposal, we had planned to use Long-Range Module for the communication between one node to the other node; unluckily we were unable to order for it with respect to the time to implement the prototype design, therefore we suggested implementing this project using Wireless Fidelity communication technology for information sharing.

We also used the Ultrasonic sensor and PIR sensor which sense wild animals and intruders' movements approaching buffer walls in the range of 4cm maximum, and 3m to 7m distances and 120 degrees respectively.

CHAPTER FIVE

CONCLUSION AND RECOMMENDATIONS

5.1 Conclusion

Wild animal's accidents are extremely hard to handle during crop raiding and affect not only farmers but also all people living close to the VNP. The buffer wall without active warning components such as automatic barriers, flashing lights, and sound the alarm present risks to both sides such as Farmers and wild animals.

The main goal of this research was to develop an automatic buffer wall and was completely done. The requirements were reviewed and analyzed, the system was developed and validation was done in order to make sure the system operates as expected and contribute to the reduction of accidents and crops raiding by wild animals in the community. It was accomplished by detecting and monitoring the motion of both wildlife and intruder approaching the buffer wall and alerting the farmers around the edges of the park of the threat.

The Automatic Escaped Animal Detection and Monitoring System developed confirmed that the information collected on the movements of wildlife and intruder could be made available automatically; therefore, based on the outputs from the functionality of the developed system, it confirmed that the effects of wild animal's accidents could be diminished through an automatic system. From the traditional system to the automation systems, there would be saving time, there is no dependent source of power, by means the system has chargeable batteries installed on each node. The system minimized the cost of equipment as well as the energy used by park rangers while making patrols. The movements of wild animals or intruders were monitored in real-time; notifications were sent to park rangers and wild animals were warned to remain in their habitats.

5.2 Recommendations

This project was developed to help out the Rwanda Development Board (RDB) in Rwanda for its present operational system, thereby removing some of the ditches and wall of stones used in the area. Therefore, from the gaps presented in the chapter one and existing systems, the followings are addressed in this project:

- (i) Training of the community around the park and campaign awareness would take place frequently to notify farmers and all people about the hazards;
- (ii) The developed system should rapidly detect and monitor wild animals approaching the buffer wall and continuously sent the information to the park officials;
- (iii) The implementation of having a centralized control room to monitor the working of the system whereby the extended of this project would meet the demands according to the situation;
- (iv) The developed system could be applied in most National Parks in Rwanda because the Automatic Buffer Wall System uses low power, presents full safety from the loss of crops, human life, wildlife and infrastructures;
- (v) The designed system could be scalable whereby developers could add different sensors and it can be added without affecting the existing systems' operation. This would tolerate the flexibility and simple maintenance of the developed system;
- (vi) The use of PIR sensor and Ultrasonic sensor that sense moving objects in at least 150meters, image detection and sending detected information to the cloud;
- (vii) The Republic of Rwanda is advised to do park expansion;
- (viii) Planting plants which are not likely by wild animals in the edges of the park.

REFERENCES

- Ada, L. (2020). Adafruit Learning System: PIR Motion Sensor. *Adafruit Learning System*, 1–28.
- Annual report 2019. (2019).
- Berger-Tal, O., & Lahoz-Monfort, J. J. (2018). Conservation technology: The next generation. *Conservation Letters*, 11(6).
- Carle, J., & Holmgren, P. (2003). Definitions related to planted forests. *UNFF Intercessional Expert Meeting on the Role of Planted Forests in Sustainable Forest Management, Wellington, New Zealand*, 329–343.
- Ceran, B., Hassan, Q., Jaszczur, M., & Sroka, K. (2017). An analysis of hybrid power generation systems for a residential load. *E3S Web of Conferences*, 14, 01020.
- Chung, L., Nixon, B. A., Yu, E., & Mylopoulos, J. (2012). Non-functional requirements in software engineering. *Springer Science & Business Media*, 5, 476.
- Corsi, N., Gemelli, A., Blaabjerg, C., Haddad, K., Song, W., Dimino, I., & Viegas, D. X. (2010). Development and Testing of Optoelectronic Sensors to Detect and Monitor Forest Fires.
- Datta, N., Sarkar, S., Malik, A., & Punetha, D. (2016). Automatic tracking and alarm system for eradication of wild life injury and mortality. *2nd International Conference on Advances in Computing, Communication, & Automation*, 1-4.
- Decisions, V., & Refinement, P. (2013). Project Refinement Identifies and Addresses Outstanding Project Risks.
- Divya, S., Kiran, U., & Praveen, M. (2018). Iot-based wild animal intrusion detection system. *International Journal on Recent and Innovation Trends in Computing and Communication*, 6(7), 06-08.
- Doberstein, D. (2012). Introduction to the global positioning system. *Fundamentals of GPS Receivers*, 23-37.
- Ebreg, A., & Greve, P. D. (2000). Buffer zone and their management. *Forests, Forestry and Biological Diversity Support Group*, October, 1–64.
- Editor, E., Client, E. D., This, R., & Tutorials, E. (2020). EasyEDA Tutorial Can I use

EasyEDA in my company?

- Fawole, W. O., Ilbasimis, E., & Ozkan, B. (2015). Food insecurity in Africa in terms of causes, effects and solutions: A case study of Nigeria. *2nd ICSAE 2015, International Conference on Sustainable Agriculture and Environment, September 30-October 03, 2015, Konya, Turkey. Proceedings Book, 1*, 6-11.
- Fezari, M., & Dahoud, A. A. (2018). Integrated Development Environment “IDE” For Arduino. *Research Gate, October*, 1–12.
- Fish, U. S., & Service, W. (2001). Native Plants for Wildlife Habitat and Conservation Landscaping. *Native Plants*.
- Girmay, T., & Teshome, Z. (2017). Human-wildlife conflicts in and around Choffa forest, Hawzien Woreda, Eastern Tigray, Northern Ethiopia: implication for conservation and conflict resolution. *International Journal of Science and Research*, 6(3), 1763-1771.
- Government of Rwanda. (2018). Republic of Rwanda Ministry of Lands and Forestry Rwanda National Forestry Policy 2018 February.
- Hanophy, W. (2009). Fencing with wildlife in mind. *XColorado Division of Wildlife*.
- Hansson, T. (2018). When the Siren Sounds: In search of acoustic properties that make an alarm signal effective at capturing attention.
- Hill, C. M. (2018). Crop foraging, crop losses, and crop raiding. *Annual Review of Anthropology*, 47(1), 377-394.
- Hirayama, M. (2016). Sensor Selection method for IoT systems—focusing on embedded system requirements. *MATEC Web of Conferences*, 59, 01002.
- Hurni, H. (2021). Late quaternary of simen and other mountains in Ethiopia. *Quaternary and Environmental Research on East African Mountains*, 105-120.
- IPAR. (2009). An IPAR Sector Review. *July*, 1-47.
- Izina, K., Izina, T. K., Sector, K., Province, N., Izina, K., Izina, K., Sector, K., Izina, K., Sector, K., District, N., Sector, N., Province, E., Ali, A., Rashid, B., Nuami, A., Sheikh, G., Rakotoarisa, N. R., Chief, P., Building, C., & International, C. (2018). *2018 Kwita Izina Baby Gorilla Namers Revealed, September*, 10-11.
- Jeevitha, S., & Kumar, V. (2020). A review of animal intrusion detection system. *International Journal of Engineering Research & Technology*, 9(5), 1219-1221.

- Kigali. (2017). *Republic of Rwanda Ministry of Trade and Industry Made in Rwanda Policy*. October.
- Knörig, A., Wettach, R., & Cohen, J. (2009). Fritzing: A tool for advancing electronic prototyping for designers. *Proceedings of the 3rd international conference on tangible and embedded interaction*, 351-358.
- Lamichhane, B. R., Person, G. A., Leirs, H., Poudel, S., Subedi, N., Pokheral, C. P., Bhattarai, S., Gotame, P., Mishra, R., & de Iongh, H. H. (2019). Contribution of Buffer Zone Programs to Reduce Human-Wildlife Impacts: The Case of the Chitwan National Park, Nepal. *Human Ecology*, 47(1), 95–110.
- Langworthy, A. D., Verdon, M., Rawnsley, R. P., Freeman, M. J., Corkrey, R., & Hills, J. L. (2021). Virtual fencing technology to intensively graze lactating dairy cattle. I: Technology efficacy and pasture utilization. *Journal of Dairy Science*, 104(6), 7071–7083.
- Lev, J., Shapoval, V., Bartoška, J., & Kumhála, F. (2017). *Low-cost infrared sensor for wildlife detection in vegetation*. 63(20163002), 13–17.
- Manual, U. (2011). *GPRS / GSM SIM900A MODEM*.
- MINALOC (2018). *The Local Government System in Rwanda Country Profile 2017–18*. Retrieved on 28 July 2021
- Mishra, R. G. (2013). Distributed Fibre Optic Virtual Fencing System. November 2013.
- MOE. (2020). *National land use & Development Master Plan NLUDMP 2020-2050*. 147.
- Munanura, I. E., Backman, K. F., Hallo, J. C., & Powell, R. B. (2016). Perceptions of tourism revenue sharing impacts on Volcanoes National Park, Rwanda: A Sustainable Livelihoods framework. *Journal of Sustainable Tourism*, 24(12), 1709–1726.
- National Institute of Statistics of Rwanda (NISR). (2015). *Statistical yearbook Chapter IX: Travel and Tourism*.
- Nasehi, A. (2013). A Quantitative Study on Critical Success Factors in Agile Software Development Projects; Case Study IT Company.
- NBSAP. (2016). National Biodiversity Strategy Plan. *National Biodiversity Strategy and Action Plan, December*.
- Numbers, M. G. (2019). *Mountain Gorilla Numbers on the Rise*.

- Obour, R., Asare, R., Ankomah, P., & Larson, T. (2016). Poaching and its Potential to Impact Wildlife Tourism: An Assessment of Poaching Trends in the Mole National Park in Ghana. *Athens Journal of Tourism*, 3(3), 169–192.
- ORTPN. (2005). Volcanoes National Park. *Management Plan 2005-2009*, 1–140.
- Paper, F. A. O. F. (2008). Forestry Human-wildlife conflict in Africa.
- Park, A. N., & Oort, J. V. (2020). *Republic of Rwanda Rwanda 6th National Report to the Convention on Biological Diversity. September.*
- Park, V. N. (2019). Quantifying tolerance to crop-raiding near protected areas A case study of Volcanoes National Park, Rwanda Thesis submitted as partial fulfilment for the master's degree. *March*, 0–78.
- Parkash, V. (2017). Role of Information and Communication Technology in Teaching Learning Process. *Learning Community-An International Journal of Educational and Social Development*, 8(1), 29.
- Patil, H., & Ansari, N. (2021). Automated Wild-Animal Intrusion Detection and Repellent System Using Artificial Intelligence of Things. *Social Science Research Network Electronic Journal*, 7(5), 1-6.
- Portable Bluetooth ® Speaker Thank You.
- RDB. (2020). *Annual Report.*
- Santhiya, S., Dhamodharan, Y., Priya, N. E. K., Santhosh, C. S., & Surekha, M. (2018). A smart farmland using Raspberry Pi crop prevention and animal intrusion detection system. *International Research Journal of Engineering and Technology*, 5(3), 3829-3832.
- Semiconductor, D., & Potentiometers, D. (2015). Application Note 69. 1–10.
- Sharma, S., Sarkar, D., & Gupta, D. (2012). Agile Processes and Methodologies: A Conceptual Study. *International Journal on Computer Science & Engineering*, 4(5), 892–898.
- Shield, G. (2014). GSM / GPRS Shield Datasheet.
- Singh, R., Gehlot, A., Vaseem, S., Kumar, A., & Buddhi, D. (2021). Forest 4.0: Digitalization of forest using the Internet of Things (IoT). *Journal of King Saud University - Computer and Information Sciences.*

- Singh, S. C. (2009). Basics of light emitting diodes, characterizations and applications. Handbook of Light Emitting and Schottky Diode Research.
- Sobana, S. (2017). An Automatic Repelling System to Reduce Human Elephants Conflicts Using Sensors. *International Journal for Research in Applied Science & Engineering Technology*, 5(V).
- Uno, A., & Front, R. (2020). *Arduino Uno*.
- Uwayo, P., Nsanzumukiza, V. M., Maniragaba, A., Nsabimana, A. P., & Akimanizanye, V. (2020). Contribution of Former Poachers for Wildlife Conservation in Rwanda Volcanoes National Park. *Journal of Geoscience and Environment Protection*, 08(04), 47–56.
- Vetter, B. (2017). Designing a smart rainwater buffer (Bachelor's thesis, University of Twente).
- Yusman, Finawan, A., & Rusli. (2018). Design of wild animal detection and rescue system with passive infrared and ultrasonic sensor-based microcontroller. *Emerald Reach Proceedings Series*, 1, 415–422.
- Zeng, C., Xiao, J., Yu, Z., & Zhang, J. (2013). *The Design of Wild Animals Monitoring System Based on 3G and Internet of Things*, 11(12), 7762–7768.

APPENDICES

Appendix 1: Datasheet of Ultrasonic (Indoware, 2013)

S/N	Particulars	Descriptions
1	Working voltage	5 V DC
2	Working current	15mA
3	Working frequency	40Hz
4	Measuring angle	15 degrees
5	Trigger signal	10uS TTL pulse
6	Echo output signal	Input TTL lever signal
7	Sensing angle	30degree
8	Distance measurement	Centimeter (cm)

Appendix 2: Arduino IDE Datasheet (Farnell, 2013)

S/N	Particulars	Descriptions
1	Working voltage	5 V DC
2	Microcontroller	ATmega328
3	Operating voltage	5V
4	Input voltage range	6V to 20V
5	Digital I/O pins	14
6	Analog I/O pins	6
7	DC current for I/O	40mA
8	DC current on 3.3V pin	50mA
9	Flash Memory	32KB
10	Clock speed	16MHz
11	SRAM	2KB
12	EEPROM	1KB

Appendix 3: GSM SIM900 (Shield, 2014)

Particulars	Descriptions
Power input	3.5V to 4.5V
Operating Frequency	EGSM900 & DCS1800
Data transfer link	Download: 85.6kbps, Upload: 42.8kbps
SMS	MT, MO, CB, Text and PDU Mode
Antenna support	Available
Serial support	I2C & UART
Serial Debug port	Available

Appendix 4: GPS NEO 6M (Neil, 2010)

S/N	Particulars	Descriptions
1	Power consumption	3.0V to 4.2V
2	Current	45mA
3	Geographic position	Latitude & Longitude
4	Operating temperature	-40°C to +85°C

Appendix 5: Automatic buffer wall setup



Appendix 6: LCD Display outputs



Appendix 7: PIR Sensor datasheet (Description, 2011)

S/N	Particulars	Descriptions
1	Working voltage range	4.5V to 20V
2	Current	50 μ A
3	High output level	3.3V/Low 0V
4	Maximum sensing distance	7m
5	Angle sensor	Less than 120 degrees
6	Working temperature	-15°C to ~70°C

Appendix 8: The automatic escaped animal detection and monitoring system codes

```
#include <LiquidCrystal.h>
#include <TinyGPS++.h>
#include <SoftwareSerial.h>
SoftwareSerial mySerial(7, 8);
int pir =A5;
int pir1 =0;
const int SIREN = A4;
const int trigPin = 4;
const int echoPin = 5;
int speaker = A1;
int Leds = A3;
int BUZZER = A2;
int RXPin = 2;
int TXPin = 3;
String spd , dst;
int GPSBaud = 9600;
String latit;
String longit;
long duration;
int distance1 = 0;
int distance2 = 0;
double Speed = 0;
int distance = 0;
const int rs = 12, en = 11, d4 = 10, d5 = 9, d6 = 13, d7 = 6;
LiquidCrystal lcd(rs, en, d4, d5, d6, d7);
// Create a TinyGPS++ object
TinyGPSPlus gps; // Create a software serial port called "gpsSerial"
SoftwareSerial gpsSerial(RXPin, TXPin);
void setup() {
  mySerial.begin(9600);
  Serial.begin(9600);
  gpsSerial.begin(GPSBaud);
```

```

Serial.println("Initializing..."); //waiting for SIM Card connection
delay(1000);
// pinMode(MOTION_SENSOR_PIN, INPUT);// set arduino pin to input mode
// pinMode(MOTION_SENSOR_PIN1, INPUT);
pinMode(speaker, OUTPUT);
pinMode(trigPin, OUTPUT); // Sets the trigPin as an Output
pinMode(echoPin, INPUT); // Sets the echoPin as an Input
digitalWrite(speaker, HIGH); pinMode(Leds, OUTPUT);
digitalWrite(SIREN, LOW);
pinMode(BUZZER, OUTPUT);
pinMode(SIREN, OUTPUT);
lcd.begin(16, 2);
  lcd.setCursor(0, 0);
  lcd.print("PARK FENCE ALERT");
  lcd.setCursor(5, 1);
  lcd.print("SYSTEM"); // delay(4000);
}
void loop() {
digitalWrite(speaker, HIGH);
digitalWrite(SIREN, LOW);
pir1 =analogRead(pir);
  distance1 = ultrasonicRead(); //calls ultrasonicRead() function below
  delay(1000); //giving a time gap of 1 sec
  distance2 = ultrasonicRead(); //calls ultrasonicRead() function below
  //formula change in distance divided by change in time
  Speed = -(distance2 - distance1) / 1.0; //as the time gap is 1 sec we divide it by 1.
  spd = (Speed * 1);
  dst = (distance * 1);
  if (pir1 > 100 ) // code to active outdoor SIREN
  {
    lcd.setCursor(0, 0);
    lcd.print("OUT ALERT....!");
    lcd.setCursor(0, 1);
    lcd.print("Please Check!!!");
  }
}

```

```

delay(2000);
lcd.clear();
lcd.setCursor(0, 0);
lcd.print("PARK FENCE ALERT");
lcd.setCursor(5, 1);
lcd.print("SYSTEM");
// Serial.println("Motion detected!");
digitalWrite(SIREN, HIGH);
digitalWrite(BUZZER, HIGH);
delay(4000);
sendsms1();
// pir1 ==0;
}
else {
// Serial.println("Motion stopped!");
digitalWrite(SIREN, LOW);
digitalWrite(BUZZER, LOW);
}
if (distance < 50 )
{
// pir1 == 0;
lcd.clear();
lcd.setCursor(0, 0);
lcd.print("IN ALERT....!");
lcd.setCursor(0, 1);
lcd.print("Please Check !");
delay(2000);
lcd.clear();
lcd.setCursor(0, 0);
lcd.print("PARK FENCE ALERT");
lcd.setCursor(5, 1);
lcd.print("SYSTEM");
// Serial.println("Motion detected!");
digitalWrite(speaker, LOW);

```



```

delay(800);
digitalWrite(speaker, HIGH);
sendsms2();
// delay(2000);
//   pir1 ==0;
digitalWrite(BUZZER, HIGH);
delay(2000);
//   pir1 ==0;
}
else {
//   Serial.println("Motion stopped!");
digitalWrite(BUZZER, LOW);
}

if (distance < 50 )//code to turn on leds
{
//   pir1 == 0;
lcd.clear();
lcd.setCursor(0, 0);
lcd.print("IN ALERT....!");
lcd.setCursor(0, 1);
lcd.print("Please Check !");
delay(2000);
lcd.clear();
lcd.setCursor(0, 0);
lcd.print("PARK FENCE ALERT");
lcd.setCursor(5, 1);
lcd.print("SYSTEM");
//   Serial.println("Motion detected!");
digitalWrite(Leds, HIGH);
delay(800);
digitalWrite(Leds, LOW);
delay(800);
digitalWrite(Leds, HIGH);

```

```

delay(800);
digitalWrite(Leds, LOW);
delay(800);
digitalWrite(Leds, HIGH);
delay(800);
digitalWrite(Leds, LOW);
delay(800);
digitalWrite(Leds, HIGH);
delay(800);
digitalWrite(Leds, LOW);
delay(800);
}
else {
  // Serial.println("Motion stopped!");
  digitalWrite(Leds, LOW);
}
if (pir1 == 1 && distance <50) {
  lcd.clear();
  lcd.setCursor(0, 0);
  lcd.print("Please Check On");
  lcd.setCursor(3, 1);
  lcd.print("Both Sides");
  delay(2000);
  lcd.clear();
  lcd.setCursor(0, 0);
  lcd.print("PARK FENCE ALERT");
  lcd.setCursor(5, 1);
  lcd.print("SYSTEM");
  digitalWrite(BUZZER, HIGH);
  delay(4000);
}
else {
  digitalWrite(BUZZER, LOW);
}

```

```

// This sketch displays information every time a new sentence is correctly encoded.
while (gpsSerial.available() > 0)
  if (gps.encode(gpsSerial.read()))
    displayInfo();
//
// If 5000 milliseconds pass and there are no characters coming in
// over the software serial port, show a "No GPS detected" error
if (millis() > 5000 && gps.charsProcessed() < 10)
{
  Serial.println("No GPS detected");
  while(true);
}
}

void displayInfo()
{
  if (gps.location.isValid())
  {
    latit = String(gps.location.lat(), 6); //Displaying Latitude & Longitude
    longit = String(gps.location.lng(), 6);
    Serial.print("Latitude: ");
    Serial.println(gps.location.lat(), 6);
    Serial.print("Longitude: ");
    Serial.println(gps.location.lng(), 6);
    Serial.print("Altitude: ");
    Serial.println(gps.altitude.meters());
  }
  else
  {
    Serial.println("Location: Not Available");
  }
  Serial.print("Date: ");
  if (gps.date.isValid())
  {

```

```

Serial.print(gps.date.month());
Serial.print("/");
Serial.print(gps.date.day());
Serial.print("/");
Serial.println(gps.date.year());
}
else
{
  Serial.println("Not Available");
}
Serial.print("Time: ");
if (gps.time.isValid())
{
  if (gps.time.hour() < 10) Serial.print(F("0"));
  Serial.print(gps.time.hour());
  Serial.print(":");
  if (gps.time.minute() < 10) Serial.print(F("0"));
  Serial.print(gps.time.minute());
  Serial.print(":");
  if (gps.time.second() < 10) Serial.print(F("0"));
  Serial.print(gps.time.second());
  Serial.print(".");
  if (gps.time.centisecond() < 10) Serial.print(F("0"));
  Serial.println(gps.time.centisecond());
}
else
{
  Serial.println("Not Available");
}
Serial.println();
Serial.println();
delay(1000);
}
void sendsms1()

```

```

{
mySerial.println("AT");
updateSerial();
mySerial.println("AT+CMGF=1");
updateSerial();
mySerial.println("AT+CMGS=\"+250788884698\");
mySerial.println("AT+CMGS=\"+250783769374\");
//mySerial.println("AT+CMGS=\"+255768269155\");
updateSerial();
mySerial.print(" OUT ALERT ! check surroundings");
updateSerial();
mySerial.write(26);
}
void sendsms2()
{
mySerial.println("AT");
updateSerial();
mySerial.println("AT+CMGF=1");
updateSerial();
mySerial.println("AT+CMGS=\"+250788884698\");
// mySerial.println("AT+CMGS=\"+255768269155\");
mySerial.println("AT+CMGS=\"+250783769374\");
updateSerial();
mySerial.print("IN ALERT ! at distance= " + dst + "cm " + "speed of " + spd + "cm/sec
please check fast");
mySerial.println("");
mySerial.print("Latitude:" + latit + ("") + "Longitude:" + longit );
updateSerial();
mySerial.write(26);
}
void updateSerial()
{
delay(500);
while (Serial.available())

```

```

{
  mySerial.write(Serial.read());
}
while (mySerial.available())
{
  Serial.write(mySerial.read());
}
}
float ultrasonicRead ()
{
  // Clears the trigPin
  digitalWrite(trigPin, LOW);
  delayMicroseconds(2);
  // Sets the trigPin on HIGH state for 10 micro seconds
  digitalWrite(trigPin, HIGH);
  delayMicroseconds(10);
  digitalWrite(trigPin, LOW);
  // Reads the echoPin, returns the sound wave travel time in microseconds
  duration = pulseIn(echoPin, HIGH);
  //calculating distance
  distance = duration * 0.034 / 2;
  // Prints the distance on the Serial Monitor
  //Serial.print("Distance in cm : ");
  //Serial.println(distance);
  return distance;
}

```

Appendix 9: Poster Presentation

Output: Poster Presentation

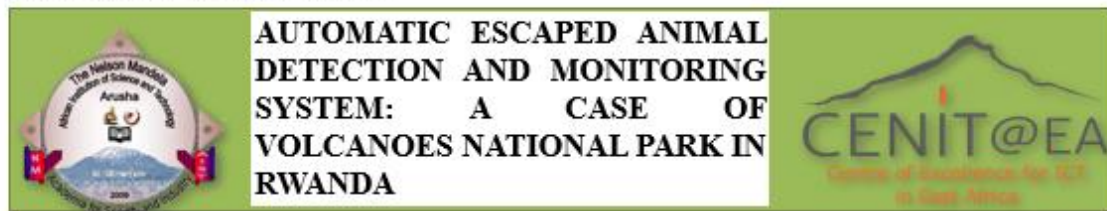

1. Innocent Zirakwiye 2. Dr Jema Ndirwile 3. Prof. Kisangiri Michael

Introduction

The Automatic Escaped Animal Detection and Monitoring System was developed to help park rangers to keep track wild animals and intruders approaching buffer wall for crop raiding and poaching activities. The government used man-made structures built for securing both farmers and people around the edges of the Volcanoes National Park (VNP). However, farmers reported that despite the efforts of building a wall around the boundaries of the park, wild animals still render their farming products. A part from crop raiding, death, injuries, compensation for the damages and pain of wildlife caused by electric fence system have been reported to be serious problems to the VNP from the use of traditional and mechanical systems which resulted negative impact to the region.

Problem statement

Next to Volcanoes National Park (VNP), farmers practice agricultural business. Animals getting out of the forest for crop raiding, buffalos kill people and people kill them. Thus, there is a conflict between farmers and the Government on how they will be compensated for the damage of their crops raided by forest animals.



Figure 1: Buffer wall (NBSAP, 2016) and Gorillas in potato field

Block Diagram

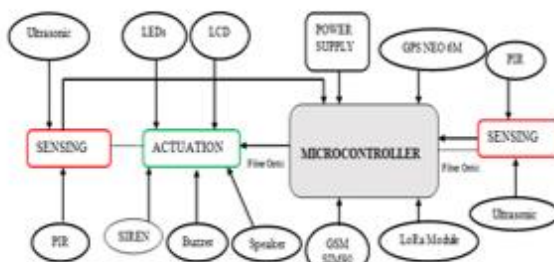

Figure 2: Building Block of the System Architecture Design

Automatic Buffer Wall

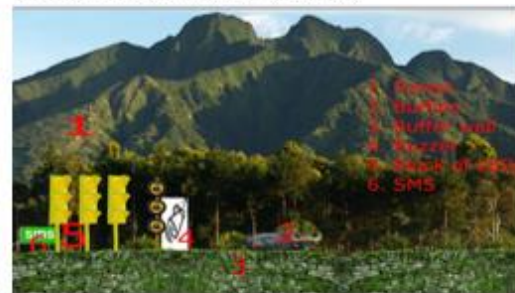

Figure 3: An Automatic Buffer Wall

Results

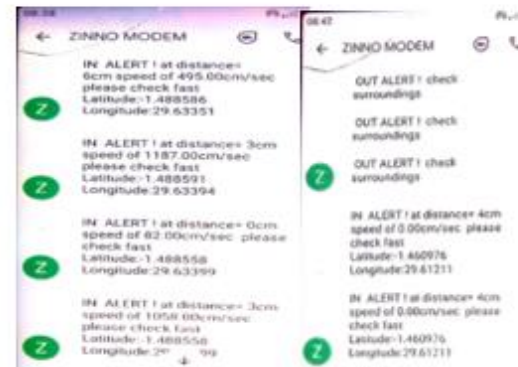

Figure 4: SMS Notifications: IN ALERT! And OUT ALERT!



Figure 5: Automatic Buffer Wall Setup

Conclusion

The buffer wall without active warning components such as automatic barriers, flashing lights, and sound the alarm present risks to both sides such as farmers and wild animals. Based on the outputs from the functionality of the developed system, it confirmed that the effects of wild animal's accidents could be diminished through an automatic system.