

2020-03

A two-way electricity usage monitoring system for decentralised solar mini-grids in Tanzania

Omary, Shaban

NM-AIST

<https://doi.org/10.58694/20.500.12479/915>

Provided with love from The Nelson Mandela African Institution of Science and Technology

**A TWO-WAY ELECTRICITY USAGE MONITORING SYSTEM FOR
DECENTRALISED SOLAR MINI-GRIDS IN TANZANIA**

Shaban Omary

**A Dissertation Submitted in Partial Fulfillment of the Requirements for the Degree of
Master's in Information and Communication Science and Engineering of the Nelson
Mandela African Institution of Science and Technology**

Arusha, Tanzania

March, 2020

ABSTRACT

Decentralised solar mini-grids have been identified as a cost-effective solution towards having sustainable electrification efforts in Tanzania, particularly to areas out of the government's immediate plans for national grid extension. Nonetheless, access to information on power consumption to both mini-grid companies and consumers has been a challenge for most of the current decentralised solar mini-grid systems. Several studies, mostly carried out outside Africa, have attempted to address the problem, however, due to the technology used, features and economic implications, the proposed solutions do not suit the local market.

With the rapid penetration of information and communication technologies services in Tanzania, access to and the use of the internet is becoming increasingly affordable for the majority of communities. This study therefore aimed at improving consumer and utility companies' access to electricity consumption information in decentralised solar mini-grids in Tanzania. This was achieved by developing a two-way electricity usage monitoring system that enhances consumers awareness towards economic utilisation of the available electrical power resources. The proposed system uses Long Range technology to create a private Low Power Wide Area Network around the mini-grid centre while General Packet Radio Service network is used to transmit power consumption data from the mini-grid centre to the cloud server.

The proposed system can help consumers to have informed-usage of electrical power and thus adjust their consumption behaviour to save unnecessary costs. The system also offers a cost-effective solution for the mini-grid companies to track the demand and supply status of the available power resources. The system also acts as a linkage between mini-grid companies and consumers which improves customer experience. Moreover, this study contributes to the existing literature by proposing an improved method to enhance equal access to the information regarding power consumption between utilities and consumers by using Long Range as a private wide area network for the mini-grid centres.

DECLARATION

I, **Shaban Omary**, do hereby declare to the Senate of Nelson Mandela African Institution of Science and Technology that this dissertation is my own original work and that it has neither been submitted nor being concurrently submitted for degree award in any other institution.

.....

Signature

.....

Date

The above declaration is confirmed by:

.....

Dr. Anael Sam
Supervisor

.....

Date

COPYRIGHT

This dissertation is a copyright material protected under the Berne Convention, the Copyright Act of 1999 and other International and National enactments, in that behalf, an intellectual property. It may not be reproduced by any means, in full or in part, except for short extracts in fair dealing, for research or private study, critical scholarly review or discourse with an acknowledgement, without a written permission of the Deputy Vice-Chancellor for Academic, Research and Innovation, on behalf of both the author and the Nelson Mandela African Institution of Science and Technology.

CERTIFICATION

I, the undersigned certify that I have read and hereby recommends for acceptance by The Nelson Mandela African Institution of Science and Technology, a dissertation entitled, “A Two-way Electricity Usage Monitoring System for Decentralised Solar Mini-grids in Tanzania” in partial fulfilment of the requirements for award of the degree of “Master’s in Information and Communication Science and Engineering.”

.....

Dr. Anael Sam
Supervisor

.....

Date

ACKNOWLEDGEMENTS

The completion of this study involves a combination of efforts and inputs from several parties and individuals. I would like to express my appreciation to the following for their support and contribution during the whole period of this research work.

I express my deep gratitude to my employer, the University of Dar es Salaam (UDSM) for granting me a 2-years study-leave, which enabled me to undertake my master's studies at the Nelson Mandela African Institution of Science and Technology (NM-AIST).

Secondly, I would like to express sincere appreciation to the African Development Bank (AfDB) who were the full sponsors of my studies at NM-AIST.

Thirdly, I would like to thank my supervisor Dr. Anael Sam for his support and guidance for the whole research period.

Lastly, many thanks should go to my classmates and the NM-AIST community at large for their support during my stay at NM-AIST.

TABLE OF CONTENTS

ABSTRACT.....	i
DECLARATION	ii
COPYRIGHT.....	iii
CERTIFICATION	iv
ACKNOWLEDGEMENTS.....	v
TABLE OF CONTENTS.....	vi
LIST OF TABLES	x
LIST OF FIGURES	xi
LIST OF APPENDICES.....	xiii
LIST OF ABBREVIATIONS AND SYMBOLS	xiv
CHAPTER ONE.....	1
INTRODUCTION	1
1.1 Background of the Problem	1
1.2 Statement of the Problem.....	2
1.3 Rationale of the Study.....	3
1.4 Objectives	3
1.4.1 General Objective	3
1.4.2 Specific Objectives	3
1.5 Research Questions.....	4
1.6 Significance of the Study	4
1.7 Delineation of the Study	5
CHAPTER TWO	6

LITERATURE REVIEW	6
2.1 Introduction.....	6
2.2 Solar Mini-Grid Systems in Tanzania.....	6
2.3 ICT Usage in Tanzania	8
2.4 Evolution of Electricity Usage Monitoring Systems	10
2.4.1 Electromechanical Meters	10
2.4.2 Automatic Meter Reading (AMR).....	10
2.4.3 Advanced Metering Infrastructure (Smart Meters)	11
2.5 Overview of Communication Technologies in Electricity Usage Monitoring Systems....	11
2.5.1 Power Line Communication (PLC).....	11
2.5.2 Global System for Mobile Communication (GSM)	12
2.5.3 General Packet Radio Service (GPRS).....	12
2.5.4 Low Power Wide Area Network (LPWAN)	12
2.6 Other Related Works.....	13
CHAPTER THREE	16
MATERIALS AND METHODS.....	16
3.1 Introduction.....	16
3.2 Research Design.....	16
3.3 Study Area	17
3.4 Population and Sampling Technique	18
3.5 Data Collection	18
3.6 Data Analysis	19
3.7 System Development Approach	19
3.8 System Modelling	20

3.9 System Implementation	20
3.9.1 Smart Meter Unit	20
3.9.2 Database Server	21
3.9.3 Server-Side Applications	21
3.9.4 Client-Side Applications.....	21
3.9.5 JavaScript Object Notation (JSON).....	21
3.10 System Testing and Validation	22
3.11 Assumptions and Dependencies	22
CHAPTER FOUR.....	23
RESULTS AND DISCUSSION	23
4.1 Introduction.....	23
4.2 Findings from the Consumers	23
4.2.1 Demographic Information	23
4.2.2 Consumers’ Access to ICT Services	24
4.2.3 Consumers’ Electricity Usage Behaviour.....	25
4.2.4 Consumers’ Awareness to Electricity Usage Information	26
4.2.5 Consumers’ Perception on the Need for Having Electricity Usage Monitoring System	26
4.2.6 Consumers’ Recommendations on the System Requirements	27
4.3 Findings from the Mini-Grid Company	27
4.3.1 Information Collected from the Mini-Grid Centres	27
4.3.2 Mini-grid Company’s Recommendations on the System Requirements.....	29
4.4 System Modelling	30
4.4.1 System Design Architecture	31
4.4.2 Smart Meter Unit	32

4.4.3 Data Transmission Unit	36
4.4.4 Web Application.....	37
4.5 System Implementation	40
4.5.1 Smart Meter Unit	40
4.5.2 Data Transmission Unit	41
4.5.3 Developed Web Application	42
4.6 System Testing and Validation	50
4.6.1 Unit Testing	50
4.6.2 System Performance Test	53
4.6.3 Acceptance Testing.....	53
4.7 Findings and Discussion	54
CHAPTER FIVE	56
CONCLUSION AND RECOMMENDATIONS	56
5.1 Conclusion	56
5.2 Recommendations.....	58
REFERENCES	59
APPENDICES	67
RESEARCH OUTPUTS.....	Error! Bookmark not defined.

LIST OF TABLES

Table 1: Communication technologies used in electricity usage monitoring systems	13
Table 2: Demographic information of consumers	24
Table 3: Consumers' recommendations on the system requirements	27
Table 4: Mini-grid company recommendations on the system requirements.....	30
Table 5: Comparative assessment of potential microcontroller boards for a smart meter....	36
Table 6: Smart meter unit testing.....	50
Table 7: User authentication unit testing	51
Table 8: Consumer management unit testing.....	51
Table 9: Grid information management unit testing.....	51
Table 10: Consumer profile information unit testing	52
Table 11: Energy visualization unit testing	52
Table 12: System performance test results	53
Table 13: System acceptance testing responses.....	54

LIST OF FIGURES

Figure 1: Registered mini-grids centres in Tanzania (World Resources Institute, 2018).....	8
Figure 2: Internet services penetration in Tanzania.....	9
Figure 3: Processes in the Design Science Research (DSR) approach.....	16
Figure 4: DSR phases matched with research questions	17
Figure 5: Rapid Application Development (RAD) lifecycle	20
Figure 6: Consumers ICT devices ownership and internet usage.....	25
Figure 7: Consumers' electricity usage behaviour.....	25
Figure 8: Consumers' awareness of electricity usage information.....	26
Figure 9: Consumers' perception of the need for the electricity usage monitoring system .	26
Figure 10: Mkalama solar mini-grid centre	28
Figure 11: Ngurdoto solar mini-grid centre	29
Figure 12: Conceptual framework of the proposed system	31
Figure 13: Smart meter unit block diagram	32
Figure 14: Current transformer and voltage transformer	33
Figure 15: Solid-state TZT relay module.....	33
Figure 16: 20 by 4 character LCD screen	34
Figure 17: DS1307 Real-time clock module	35
Figure 18: Atmega2560, Raspberry Pi and Nucleo-F410re microcontroller boards	35
Figure 19: LoRa module used for data transmission	37
Figure 20: Flowchart diagram for data transmission unit.....	37
Figure 21: Use case diagram for the system's web application	38
Figure 22: System data flow context diagram	39
Figure 23: Web application database schema.....	39
Figure 24: Smart meter unit during system testing.....	40
Figure 25: Smart meter unit enclosed inside a waterproofing box	40
Figure 26: LoRa base station	41
Figure 27: Local monitoring centre and the GPRS gateway	41
Figure 28: System administrator login page	42
Figure 29: Consumer login page.....	43
Figure 30: Grid power consumption dashboard.....	44
Figure 31: Registered mini-grids	44

Figure 32: Registration of a new mini-grid centre.....	45
Figure 33: Consumer management interface	45
Figure 34: Consumer profile and electricity usage history	46
Figure 35: Notification algorithm flowchart diagram.....	47
Figure 36: Usage status notification SMS	47
Figure 37: Customer support page.....	48
Figure 38: Integration between the payment system and monitoring system.....	49
Figure 39: Payment confirmation message sent to the consumer.....	49

LIST OF APPENDICES

Appendix 1: Questionnaire for Data Collection	67
Appendix 2: Questionnaire for System Validation	70
Appendix 3: Sample Arduino Codes for Smart Meter Unit	71
Appendix 4: Sample PHP Codes for Web Application	74

LIST OF ABBREVIATIONS AND SYMBOLS

ACRONYM	DEFINITION
2G	Second Generation
3G	Third Generation
3GPP	Third Generation Partnership Project
4G	Fourth Generation
AC	Alternating Current
AMI	Advanced Metering Infrastructure
AMR	Automatic Meter Reading
DBMS	Database Management System
DC	Direct Current
DFD	Data Flow Diagram
DSR	Design Science Research
EDGE	Enhanced Data For GSM Evolution
EWURA	Energy and Water Utilities Regulatory Agency
GPRS	General Packet Radio Service
GSM	Global System for Mobile Communication
HSPA	High Speed Packet Access
HTML	Hypertext Mark-up Language
HTTP	Hyper-Text Transfer Protocol
IBRD	International Bank for Reconstruction and Development
ICT	Information and Communication Technologies
IEA	International Energy Agency
IEEE	Institute of Electrical and Electronics Engineers
IoT	Internet of Things
IT	Information Technology
JSON	JavaScript Object Notation
LCD	Liquid Crystal Display
LoRa	Long Range
LoS	Line of Sight
LPWAN	Low Power Wide Area Network
LTE	Long Term Evolution

NBS	National Bureau of Statistics
NEMC	National Environment Management Council
ORDBMS	Object-oriented Relational Database Management System
PHP	Hypertext Pre-Processor
PLC	Power Line Communication
RAD	Rapid Application Development
REA	Rural Energy Agency
RF	Radio Frequency
SHS	Solar Home System
SMPP	Short Message Peer-to-Peer
SMS	Short Message Service
SPP	Small Power Producers
SQL	Structured Query Language
SSA	Sub-Saharan African
TANESCO	Tanzania Electricity Supply Company Limited
TCRA	Tanzania Communications Regulatory Authority
UML	Unified Modelling Language
UMTS	Universal Mobile Telephone Systems
VAS	Value Added Services
WAN	Wide Area Network

CHAPTER ONE

INTRODUCTION

1.1 Background of the Problem

Recently, global demand for electricity has risen significantly due to population growth, climate change and technological advancement, whereas a recent statistics indicate an average annual power demand level of 4% over the past five years (International Energy Agency, 2018). However, Tanzania is among the Sub-Saharan African (SSA) countries known to have relatively low electrification rates, especially in areas far from the national grid. A research conducted by the World Resources Institute show that less than 40% of households have access to electricity supply out of the nearly 50 million people in Tanzania. It has been also reported that 75% of the electrified households are supplied through the national grid, while the remaining 25% rely on solar power and other private sources, including diesel engines (World Resources Institute, 2018).

Conventional grid extension has been a predominant mode of electrification in several countries. Nonetheless, decentralised solar mini-grids have been emerging as a cost-effective solution to electrification efforts in SSA countries, besides national grid extension and stand-alone Solar Home Systems (SHS) approaches (Hartvigsson, Ehnberg, Ahlgren & Molander, 2015). Several works of literature have defined mini-grids as decentralised power generation and distribution systems with an installed capacity of less than 2 MW that may utilise different power sources such as solar, biomass, hydropower, wind, diesel generators or any combination of these that serve consumers at a local distribution scale (Pedersen, 2016).

For the past decade, Tanzania has made significant progress in electrification efforts through grid extension, generation capacity and removing barriers for private off-grid investments. Several measures have been taken to address the problem. This includes the enactment of the Electricity Act (2008), a reform that resulted into the creation of Small Power Producers (SPP) framework and Rural Energy Agency (REA), a government agency responsible for promoting improved access to electricity in rural areas (Ahlborg & Hamma, 2011). Additionally, the Ministry of Energy had set out the National Electrification Program Prospectus to increase the penetration of electricity by 50% and 75% by 2020 and 2035, respectively (Wizara ya Nishati, 2019). However, due to budget constraints, expanding the

national grid to all community areas within the specified timeline is not economically feasible (Chaplin *et al.*, 2017). This is due to the nature of the settlements since most people live in remote settlements far from the national grid network. The Ministry of Energy has amended the SPP framework to provide an enticing environment for the mini-grid companies to invest in electrification projects (Wizara ya Nishati, 2019). Several companies have been playing a significant role in the distribution of decentralised power sources throughout the country.

While private companies run most of these solar mini-grids, and since these projects are typically resource-constrained; stakeholders' access to information on how the installed power resources are utilised is necessary for the sustainability of the mini-grids. To achieve this, it is important to have a cost-effective, stakeholder-involved mini-grid monitoring system (Harper, 2014; Segatto, de Oliveira Rocha, Silva, Paiva & do Rosário Santos, 2018).

1.2 Statement of the Problem

One of the challenges facing the existing decentralised grid systems is the lack of efficient and cost-effective electricity usage monitoring systems (Khadar, Ahamed, Madanpalli & Nagaraj, 2017). The monitoring technologies used in the current decentralised grid systems focus mainly on providing consumption information to the mini-grid companies only, whereas consumers have very little or no access to the information on how they use power. Lack of a user-friendly monitoring system translates into a barrier towards raising consumers' awareness of the information regarding the use of electricity (Lloret, Tomas, Canovas & Parra, 2016).

Several studies, mostly carried outside Africa, have attempted to address the problem, but they have several limitations (Odarno, Sawe, Swai, Katyega & Lee, 2017). The proposed solutions either cannot be directly adapted to our local environment due to cost, used technology, or they miss some features that suit the target market. For instance the use of Power Line Communication (PLC) which has been proposed by several studies could be highly affected by noise and interference from power stability issues in our grid systems. Hence, improving mini-grid infrastructure to enhance stakeholder access to power consumption information remains a knowledge gap in the current mini-grid systems. Therefore this study aims to develop a two-way electricity usage monitoring system that will enhance equal access to power consumption information for both utilities and consumers.

1.3 Rationale of the Study

Access to electricity power consumption data has become a major concern in many countries due to the rise of utility bills. People need access to such information in order to adjust their usage behaviour to their economic status. Furthermore, mini-grid companies need to monitor the utilization of their mini-grid centres in order to be able to pinpoint power demand and supply situation. This study proposes a two-way electricity usage monitoring system that can address the above needs through:

- (i) Collecting power consumption data from consumer smart meters by deploying a private Wide Area Network (WAN) across the mini-grid centre.
- (ii) Providing a web portal that can enable both mini-grid companies and consumers to access power consumption data.
- (iii) Integrating usage notification feature to the system that sends alert messages to the consumers during critical usage situations such as when the units are about to get finished.

1.4 Objectives

1.4.1 General Objective

The main objective of this research was to develop a two-way electricity usage monitoring system for decentralized solar mini-grids that would enhance stakeholders' access to electricity usage information in Tanzania.

1.4.2 Specific Objectives

The specific objectives of this research were:

- (i) To identify and establish requirements for a two-way electricity usage monitoring system for decentralised solar mini-grids in Tanzania.
- (ii) To develop a two-way electricity usage monitoring system for decentralized solar mini-grids for linking mini-grid companies and consumers.
- (iii) To validate the developed two-way electricity usage monitoring system.

1.5 Research Questions

This study was aimed to address the following research questions:

- (i) What are the expectations of people on having an online platform for accessing electricity consumption information?
- (ii) What are the system requirements and the right methodologies for developing a two-way electricity usage monitoring system for decentralised mini-grids?
- (iii) How will the proposed system be validated to ensure that it meets end-users' expectations?

1.6 Significance of the Study

This study is expected to provide significant contribution to the society and the scientific community as follows:

- (i) With the developed system, consumer awareness on electricity usage can be enhanced. Research shows that consumers can save up to 15% of their electricity consumption if they can easily access their information about the use of electricity (Vine, Buys & Morris, 2015). Eventually, this awareness can help consumers to adapt their consumption habits to their economic status, hence saving unnecessary cost (Alahakoon & Yu, 2016).
- (ii) The system can provide a linkage between mini-grid companies and consumers. Consumers' access to historical power consumption information, credit balance and usage notification alerts, will improve customer experience by adding value-added services (VAS) to the mini-grid company (Beigh, 2019).
- (iii) As a centralised data management platform, the system can be utilised for many useful purposes. Utility companies can use the platform as a source of data for assessing current and future power demands in order to minimise new investment costs (Barman, Yadav, Kumar & Gope, 2017). The government could use the data collected from the mini-grid centres to determine the need to extend the main grid to those community areas.

- (iv) The portal can enable all users to access the system via a uniform platform like any other resource on the web. Also, the proposed system does not need custom downloads, installation and upgrade hustles which simplify development and troubleshooting (Kamilaris, Trifa & Guinard, 2010).
- (v) This study is also going to provide significance contribution to the scientific community by proposing a new methodology of enhancing equal access to power consumption information to stakeholders in decentralised mini-grid centres. The study demonstrates how Long Range (LoRa) and General Packet Radio Service (GPRS) can be integrated to deploy a cost-effective grid monitoring network for the mini-grid centres.

1.7 Delineation of the Study

Monitoring of power in grid systems is a broad field. This research is not intended to cover the entire domain of grid network monitoring. Rather, it focuses on monitoring of real power consumption data from single phase smart meters installed alongside consumer households. Other parameters such as power quality, electrical surge, abnormal usages and power theft across the grid power lines have not been covered.

CHAPTER TWO

LITERATURE REVIEW

2.1 Introduction

This chapter presents a review of literature on various areas used to establish the requirements of the proposed system. It begins by evaluating the situation of the solar mini-grid market and then examining the penetration and the usage of Information and Communication Technologies (ICT) in Tanzania, particularly access to the internet. After that, the history and the evolution of electricity usage monitoring systems have been discussed. Finally, similar studies on electricity usage monitoring systems from other researchers have been discussed thoroughly by identifying their strengths and limitations.

2.2 Solar Mini-Grid Systems in Tanzania

Tanzania's energy sector is governed by the Ministry of Energy, which is responsible for the establishment of policies and regulations regarding energy resources and their utilisation. By collaborating with other government agencies such as Electricity and Water Utilities Regulatory Agency (EWURA), National Environment Management Council (NEMC), Tanzania National Electricity Supply Company (TANESCO) and Rural Energy Agency (REA), the Ministry oversees the implementation of different projects and investments in energy resources in Tanzania mainland (Wizara ya Nishati, 2019).

Electrification projects are usually implemented via three main approaches; national grid extension, Solar Home Systems (SHS) and decentralised mini-grids. Each of the mentioned approaches is usually preferable for some scenarios, as several parameters need to be considered; including economic feasibility, nature of the settlements and potential energy demand of the particular area (Chaplin *et al.*, 2017).

The government fully manages electricity expansion projects from the national grid, whereby TANESCO is responsible for planning, generation, transmission and distribution of electricity nationwide and to nearby partner countries in the East African region. National grid electrification projects usually require large capital investments and are therefore only economically feasible for densely populated urban centres, industrial and business centres (Pedersen, 2016).

For rural and remote scattered community areas, the viable option is to install SHS, providing each house with a stand-alone solar power system for domestic use. Several companies, including Mobisol, OffGrid-Electric and GreenLink Power have been involved in the importation, selling and distribution of SHS to many rural communities areas in Tanzania (Tanzania Renewable Energy Association, 2019). Although SHS have been instrumental in providing short term electrification to many rural communities, they still suffer from several technical and economic shortcomings. Apart from high upfront costs relative to the effective power that the SHS can deliver, these systems are usually limited to low power uses, such as lighting and charging of low power appliances (Chattopadhyay, Bazilian & Lilienthal, 2015).

From the weaknesses of the above two approaches, decentralised solar mini-grids play a hybrid role. In areas outside the government's immediate plans in extending the national electricity grid, installing distributed solar mini-grids has proven to be a feasible solution (Alahakoon & Yu, 2016). Additionally, once the national grid extends to the mini-grid centres, it is possible to connect the mini-grid source to the national grid, provided that the design of the mini-grid systems embeds features that make it compatible with the national grid connection (Chattopadhyay *et al.*, 2015). As of February 2017, there were a total of 106 registered mini-grids operating in Tanzania with a total capacity of 157.7 MW, out of which solar-based mini-grids account for 11.9%. Some of the established solar mini-grid companies in Tanzania include Devergy, Jumeme Electrical and Power-Gen, whose projects are currently based in the northern and lake zone regions of Tanzania (Odarno *et al.*, 2017).

Figure 1 shows the map indicating the distribution of mini-grid power sources in Tanzania. The map indicates only those sources with a generation capacity of 1 MW and above. Nearly all solar-powered mini-grids are decentralised sources as indicated from the map, they are not connected to the national grid system.

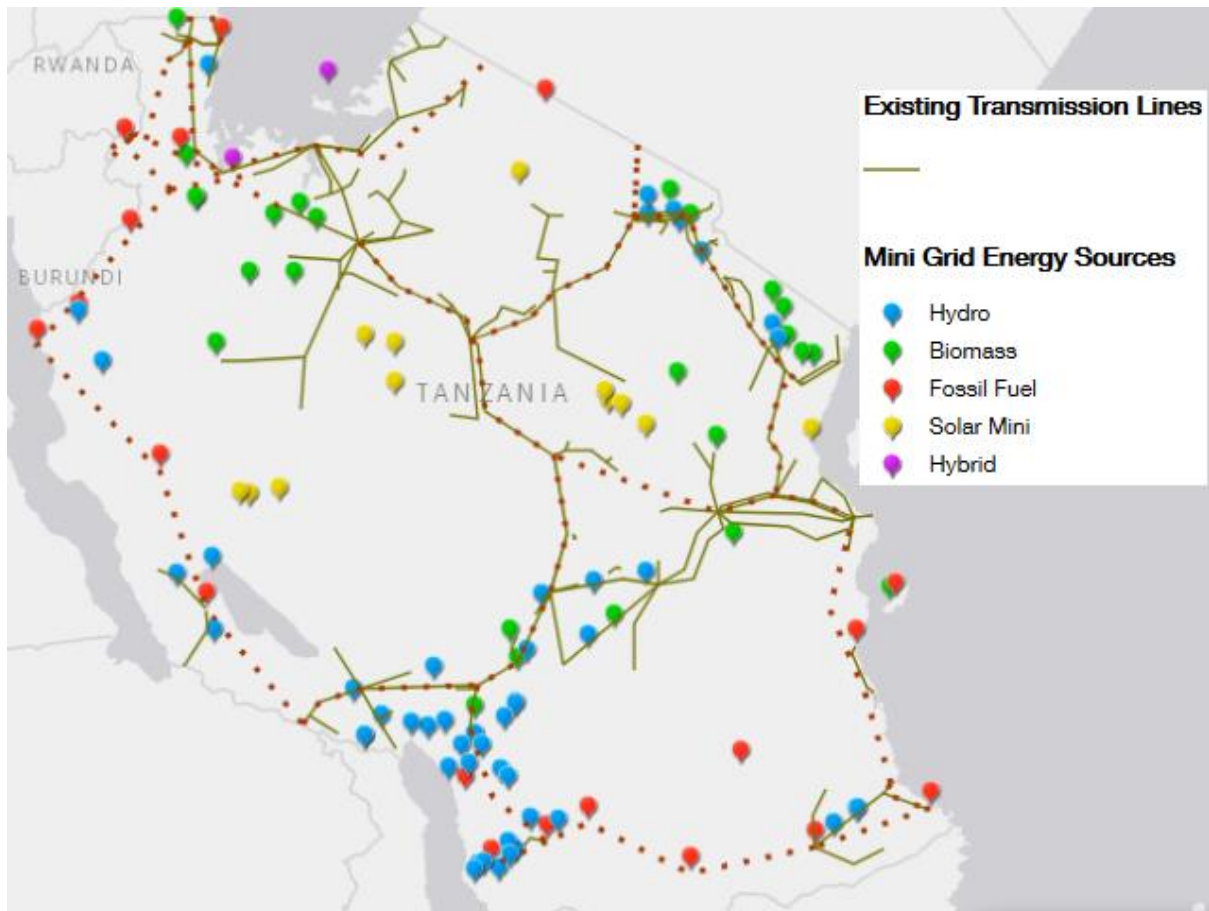

Figure 1: Registered mini-grids centres in Tanzania (World Resources Institute, 2018)

The primary advantage of having a solar mini-grid system is that, instead of purchasing a complete SHS, the consumer only needs a power line connection from the mini-grid centre (Palit & Kaushik, 2015). It is therefore evident that solar mini-grid power sources are the complementary alternatives for areas where the national grid systems can not be economically extended within the coming few years (Odarno *et al.*, 2017).

2.3 ICT Usage in Tanzania

Sub-Saharan Africa has witnessed rapid development and expansion of cellular communication networks over the past two decades than any other region in the world (Dipolelo, 2016). The rapid expansion of these technologies has transformed how people access, use and share information in their day-to-day activities (Taghandiki, Zaeri & Shirani, 2016). Because of its extensive coverage and inexpensiveness of mobile gadgets, cellular technology has become a useful means of accessing and sharing information for many areas in Africa (Techpoint Africa, 2018). Cellular communications technology developments are

apparent in developing countries because it serves as an alternative to wired broadband networks that are not well established in most of the SSA countries. (Global Statistics, 2018).

In Tanzania, the massive increase in the utilisation of ICT services can be evidenced by the quarterly statistical reports published by the Tanzania Communication Regulatory Authority (TCRA). The quarterly report of June 2019 shows that more than 43 million people (equivalent to 81% penetration) have access to mobile phone communication services while more than 23 million people (equivalent to 43% penetration) have access to the internet as shown in Fig. 2 (TCRA, 2019).

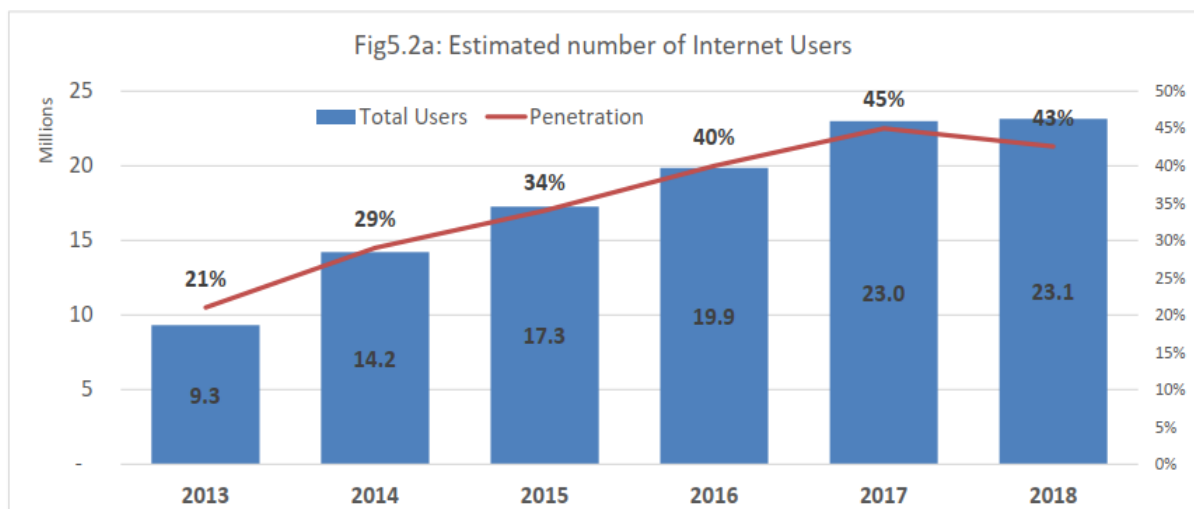

Figure 2: Internet services penetration in Tanzania (TCRA, 2019).

From the above statistical data, it is evident that Tanzania's internet penetration rate has increased by 100% over the past 5 years. Therefore, there is a need to utilise the rapidly growing ICT penetration to enhance access to energy consumption information to both stakeholders. Access to this information can facilitate several aspects, including raising awareness of electricity usage to consumers, resulting in the economical utilisation of the available electrical power resources. Additionally, other services such as payment systems can be added on top of the system to create an integrated system. Furthermore, the government can use this platform as a source of data for assessing the need to extend the main grid to areas with large power demands.

2.4 Evolution of Electricity Usage Monitoring Systems

The technologies used for monitoring of electricity usage have evolved a lot since electricity emerged as a utility in the late 19th century. An electricity meter is the fundamental component of any consumer usage monitoring in electrical utility systems. The first commercial electricity meters were made of electrolytic-based Direct Current (DC) meter which measures energy consumption by periodically weighing electrolytic plates. Since then, electricity metering systems have undergone significant technological evolution as described in the next subsections.

2.4.1 Electromechanical Meters

The continuous advancement in electromagnetism resulted in the adoption of electromechanical meters in grid systems, that are still used in several countries (Garcia, Marafão, Angelino De Souza & Pereira Da Silva, 2017). These meters use a rotating metal disc whose rotational speed is proportional to the amount of electrical current that passes through the meter. Although they have been in use for a long time, these conventional meters have got several technical limitations. They are labour intensive during meter reading and bill collection as utility workers have to visit each customer house to record energy consumption and then deliver electricity bills later. This bill processing demands much time and is vulnerable to human reading errors (Saumu, 2012).

2.4.2 Automatic Meter Reading (AMR)

Recent developments in electronics and Information Technology (IT) have resulted in phasing out traditional electromechanical meters, replacing them with digital meters. These metering systems do not require human intervention to track, process and deliver bills since they automatically perform these tasks by communicating with the utility centre remotely (Palaniappan, Asokan, Bharathwaj & Sujaudeen, 2015). Such AMR systems offer several advantages, including reducing operating costs by removing intensive labour and human-caused errors during bill processing.

However, these meters still have some downfalls; the communication part is mostly one-way biased between meters and the utility company, whereas customers can only access the usage information when they are in the vicinity of their homes (Yu Energy, 2019).

2.4.3 Advanced Metering Infrastructure (Smart Meters)

Further technological development has resulted in the introduction of smart meter systems, which is an improved version of AMR. In addition to automating bill recording and processing, it is expected that these metering systems will have more intelligence on raising awareness of the economical use of electricity for utility providers and customers. In addition to other features, they provide remote meter control capability, power quality measurement and detection of abnormal usage (Weranga, Kumarawadu & Chandima, 2013).

2.5 Overview of Communication Technologies in Electricity Usage Monitoring Systems

Recent advances in communication technologies have resulted in the transformation of power distribution systems into smart grids. A smart grid network is associated with remote monitoring of the electrical power generation, distribution and consumption. Power usage monitoring systems play a vital role in monitoring and controlling the various sections of the grid network to ensure that the electricity distribution system functions efficiently and effectively (El Brak & Essaaidi, 2012). Billing systems, revenue collection and grid extension plans all depend on the efficiency of the electrical power monitoring system. The rapid development of ICT has made it possible for utility companies to implement appropriate communication technologies to track electricity consumption in grid systems. The most popular communication technologies used in electricity usage monitoring systems include Power Line Communication (PLC), Global System for Mobile Communications (GSM), General Packet Radio Service (GPRS) and Low Power Wide Area Network (LPWAN) (Supriya, Magheshwari, Sree Udhyalakshmi, Subhashini & Musthafa, 2015).

2.5.1 Power Line Communication (PLC)

Over the past three decades, PLC has become increasingly popular among the researchers as a potential communication technology for power distribution systems. This method is convenient as it uses the existing Alternating Current (AC) power lines to transmit information across the grid network (Papadopoulos, Kaloudas, Chrysochos & Papagiannis, 2013). While this technology offers a cost-effective grid monitoring solution, it is highly affected by noise and interference due to power stability and power quality fluctuations. In addition to that, it is relatively suitable for areas with high density of consumers per power distribution station (Cohen, 2014; Segatto *et al.*, 2018).

2.5.2 Global System for Mobile Communication (GSM)

Global System for Mobile Communications (GSM) is a second-generation cellular communication technology that uses Frequency Division Multiple Access (FDMA) and Time Division Multiple Access (TDMA) to transfer information between end devices. The technology supports voice and Short Message Services (SMS) (Patil, Patil, Patil & Patil, 2015). Because of its wide coverage, GSM can be a cost-effective solution for mini-grid communication technologies, where information from consumer meters is transmitted via SMS to the utility centre. This technology uses Short Message Peer-to-Peer (SMPP) as a messaging protocol, which is suitable for short and bulk messaging applications (Unifonic, 2017).

2.5.3 General Packet Radio Service (GPRS)

General Packet Radio Service (GPRS) is a packet-oriented cellular communication technology that provides internet connectivity to devices with an initial data rate of up to 172 kbps while utilising the existing GSM infrastructure (Kuzlu, Pipattanasomporn & Rahman, 2014). Under the Third Generation Partnership Project (3GPPP), GPRS is an evolving technology to have a Universal Mobile Telephone Systems (UMTS) family of technologies composed of Third Generation (3G), High-Speed Packet Access (HSPA) and Long Term Evolution (LTE) technologies. This technology uses Hypertext Transfer Protocol (HTTP) as a messaging protocol which is a more flexible protocol compared to SMPP, such that messages can be customised to handle as many parameters as required by end nodes (Unifonic, 2017).

2.5.4 Low Power Wide Area Network (LPWAN)

Low Power Wide Area Network (LPWAN) comprises of recent wireless technologies which use low power to transmit data over a long distance (Mekki, Bajic, Chaxel & Meyer, 2019). The popular LPWAN technologies are Long Range (LoRa), Sigfox and Narrow Band IoT (NB-IoT). Among these technologies, LoRa implementation has gained significant acceptance in embedded systems and IoT due to its advantages over Sigfox and NB-IoT. Having higher noise immunity and ability to transmit data over long distance while using license-free spectrum makes LoRa a cost-effective solution for private companies to create a private wide area network for embedded systems (Cattani, Boano & Römer, 2017). Table 1 summarises the features of the different communication technologies used grid monitoring systems.

Table 1: Communication technologies used in electricity usage monitoring systems

Technology	Cost	Range	Advantage	Limitation
PLC	Medium	1-3 km	Low cost. Does not need extra cabling	Affected by noisy channel, due to unstable power supply. Signal attenuation from distribution transformers.
GSM	Low	1 – 10 km	Wide coverage	Low data rates. Not scalable.
GPRS	Medium	1-10 km	Wide coverage	Costs related to data.
LoRa	Low	2-15 km	Uses licence free spectrum Wide Coverage	Higher packet loss in Non LoS environment.

2.6 Other Related Works

Monitoring of electricity consumption is an important aspect in grid systems because the information is used for assessing power demand and supply status of the particular consumer market. In addition to facilitate billing processes, an efficient monitoring system also facilitates troubleshooting and fault detection, hence minimizing power outages. Several scholars have explored recent developments in electricity usage monitoring systems. Recent topics in smart grid systems include improving utility-customer collaboration towards economic utilisation of the available electrical power resources (Khadar *et al.*, 2017).

In one of the study, Alahakoon and Yu (2016) focused on the issue of big data analytics, cloud computing and the Internet of Things (IoT) in smart metering systems. The study finds that the advancement of energy metering systems has changed the way the utility companies have to manage data from smart grid networks. Moving from monthly data to hourly data recording represents a massive volume of data to manage, thus requiring efficient technology and algorithms on data processing for a utility company with a large consumer base. The study recommends the use of cloud computing as a solution to data storage and processing that will allow both utilities and consumers to access and track energy usage efficiently.

In another study, Joshi, Kolvekar, Raj and Singh (2017) proposed an IoT based smart energy meter based on the GSM communication, which enables users to access current reading and associated costs on the web page. Also, when the user-defined threshold has been exceeded during regular usage, one can receive an SMS notification. The user can adjust the threshold limit by using this feature, while the meter can also be turned ON or OFF remotely when needed. However, the system not only provides less information to the consumer, but also does not take into account stakeholders' recommendations during system development. The system requirements, therefore, are based on the author's opinions.

In another study, Ugonna, Ademola and Olusegun (2018) proposed a GSM-based electricity monitoring system for managing consumer meters. The system employs a GSM modem to relay command and data messages between the utility centre and the meter via SMS. Power reading, remote connection and disconnection are the main features which can be accessed by the utility company via a mobile phone. Since the system lacks consumer involvement, the author recommends the integration of user-friendly web portal, in addition to SMS functionality to make the system more user-friendly to the consumers.

In another study, Hassan, Ashruf, Bhat and Beigh (2019) proposed a GSM-based electricity monitoring system that is capable of reading and sending electricity usage data through a GSM modem to the cloud server. A consumer can access electricity usage and billing information via SMS, as well as automatic turning OFF the meter upon tampering detection. However, in addition to limited data visualisation platform, the system sends a notification to the consumer only when electricity credits are exhausted, which adds little user experience towards electricity usage awareness.

In another study, Ashna and Sudhish (2013) proposed an automatic meter reading system based on GSM, with a web portal for managing billing data from consumers. Thereafter, the processed bill is distributed to the consumers via Short Message Service (SMS). A user can pay for the electricity bill and view consumed units through mobile phone SMS. However, the system lacks the user-friendly two-way communication between the utility company and consumer because the web interface is only used for bill processing, hence not giving the consumer full access to electricity usage information.

As discussed above, most of these solutions do not provide consumers equal access to their

power consumption information as mini-companies do. In addition to that, relying on public cellular networks such as GSM for monitoring power consumption information increases operating cost particularly in areas with large number of consumer houses because each smart meter needs to be fixed with GSM cards with enough data packages.

Therefore this study addressed the above limitations by proposing a two-way electricity usage monitoring system that can be accessed equally by both parties while minimising operating cost by deploying a private wide area network around the mini-grid centre which collects power consumption data from all smart meters. Compared to previous studies, the proposed system has put more emphasise on low-cost system design, stakeholder-driven system requirements and sustainability of the system by utilising the available technologies and infrastructures for system development.

CHAPTER THREE

MATERIALS AND METHODS

3.1 Introduction

The chapter discusses in detail the materials and methods used to undertake this research. It covers the study area, sampling methods, data collection techniques as well as how the system was developed and validated.

3.2 Research Design

Research design is a framework that comprises of procedures and methods that a researcher uses to gather, analyse information and formulate a solution to the specified research problem. In this study, Design Science Research (DSR) approach was used as a research design approach. This approach was chosen because it enables researchers to accurately and collaboratively document their research undertaking process from problem definition to solution evaluation (Hanid, 2014). Since there are different DSR models from the literature, in this study, the DSR was grouped into three main processes, namely, creating awareness of the problem, design science evaluation and finally evaluating the practical solution. Figure 3 illustrates the main DRS stages followed this study.

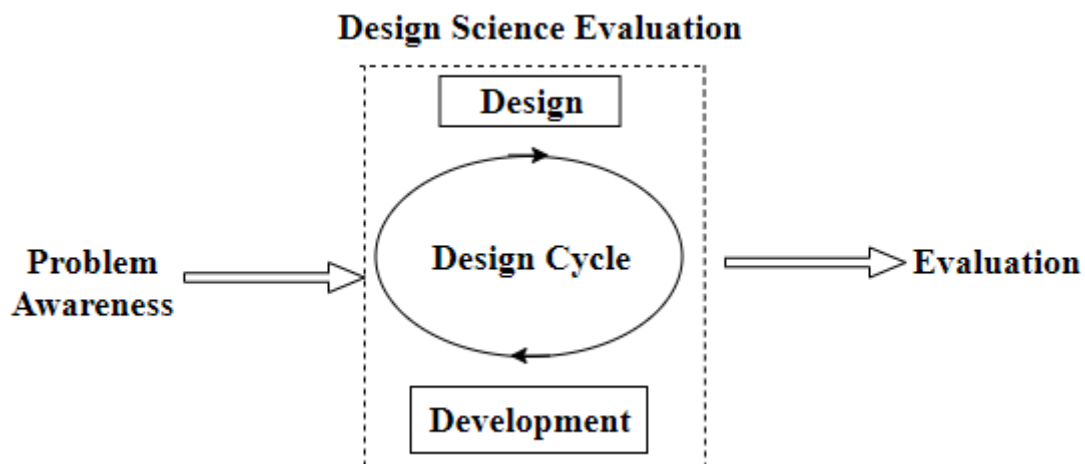

Figure 3: Processes in the Design Science Research (DSR) approach (Hanid, 2014)

Problem Awareness phase involves conducting an in-depth review of the current situation regarding the research problem. This includes conducting a critical literature review, related

works, visiting the field to determine the extent of the problem to be assured that the proposed solution can be useful to the target stakeholders.

Design Science Evaluation phase consists of two stages, design and development. The design stage involves collecting system requirements from stakeholders and other secondary resources and formulating a conceptual framework of the proposed solution. Development phase involves the real implementation of the proposed solution to meet the end-users' expectations.

Evaluation phase involves assessing the performance and usability of the developed solution. This is conducted in order to determine if the proposed solution meets end-users' expectations. Figure 4 shows how the DSR was used as a guide research framework to find answers about research questions.

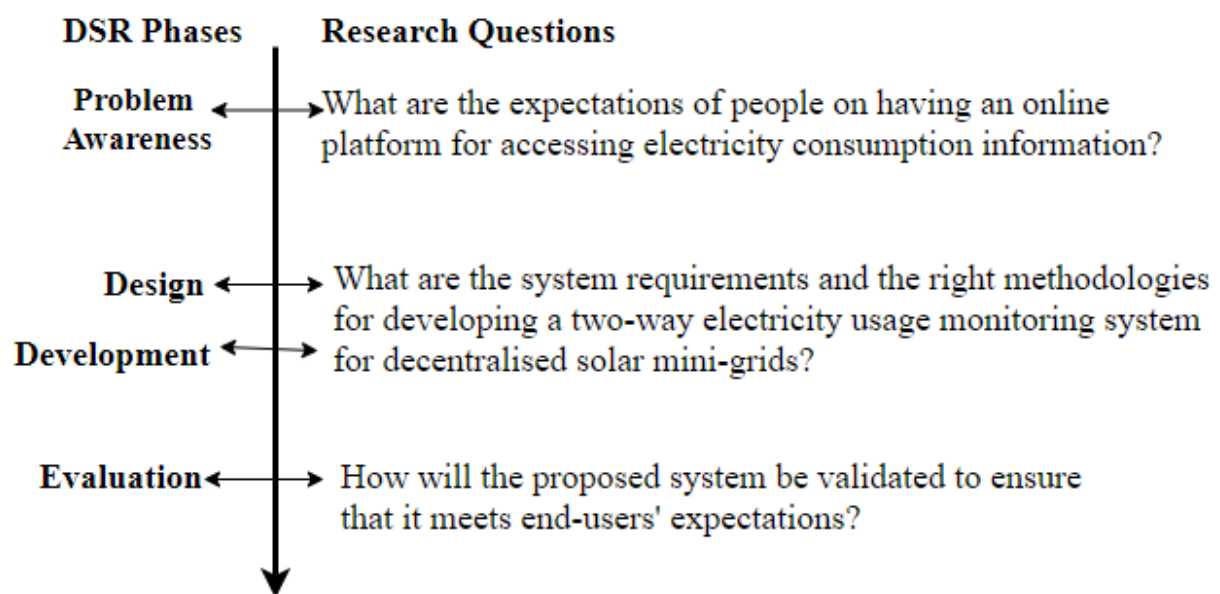

Figure 4: DSR phases matched with research questions

3.3 Study Area

This study was carried out in Ngurdoto Arusha and Mkalama Kilimanjaro regions located on the Northern part of Tanzania. These areas were selected because there are solar mini-grid centres supplying power to communities who have no access to the national grid (SmartSolar Tanzania, 2018). Ngurdoto, a village with a population of more than 4000 people, is depending on a single 10 kW mini-grid centre for electricity supply where at least 57 houses as of August 2019, have been connected to the mini-grid centre. Mkalama, a village located

about five kilometres from Bomang'ombe town, has a 10 kW solar plant which supplies power to more than 83 family households as of August 2019. Both areas have a good coverage of cellular communication networks and at least 39% of the whole population have smart phones and other gadgets which can access the internet.

3.4 Population and Sampling Technique

In this study, the target population sample was selected to determine the extent of the problem and identify the requirements needed to develop a two-way electricity usage monitoring system for decentralised mini-grids. To achieve this, a non-probability purposeful sampling technique was used to collect information from consumers whose houses have been connected to solar-powered mini-grid centres. This technique was used because it does not attempt to select a random sample from the population but instead uses subjective methods to select the sample size so that the survey data is collected from respondents who are expected to be the primary users of the proposed system (Palinkas *et al.*, 2016).

A total of 106 respondents were involved in this study, from which 63 were from Mkalama and 43 were from Ngurdoto. Also, five technical staff from the mini-grid company were involved in data collection, system design and system testing.

3.5 Data Collection

The data collection activity for this study was conducted for a period of 20 days from 15th February to 10th April 2019. To obtain sufficient and relevant information to develop a proposed solution, both qualitative and quantitative approaches were used. The qualitative approach, which involved unstructured interviews, discussion and participatory observation, was used to collect technical information required for the development of the proposed system. The quantitative approach, which involved well-structured questionnaires, was used in collecting consumers' awareness and their perception towards the usefulness of the proposed system.

The questionnaire guide for consumers consisted of three sections; demographic information, access to ICT services and consumers' awareness towards having an online electricity usage monitoring system. Demographic information was collected to determine the correlation between the usefulness of the system proposed and the ability of potential users to use the system. Furthermore, information regarding respondents' access to ICT services was

collected in order to assess the penetration rate and utilisation of ICT services to the study area since the proposed system largely depends on the application and access to the internet. Moreover, information on respondents' awareness of the electricity energy monitoring system was aimed at studying consumers' power consumption knowledge and their perception towards having an online electricity usage monitoring system. These questionnaires were filled by sampled people at their consent but under supervision.

Furthermore, a mixed research methodology was used to collect relevant data for the establishment of functional and non-functional requirements of the proposed system. These requirements were collected from consumers, technical staff, online sources, documents and research papers related to electricity usage monitoring systems.

3.6 Data Analysis

Data collected from the study areas were grouped into two categories, quantitative data and qualitative data. Quantitative data was analysed by using Python, a programming language suitable for data analytics. Since the purpose of the questionnaires was to assess the consumers' awareness and perception of having an online electricity monitoring platform, the frequencies and percentages were interpreted and inferences were drawn.

Qualitative data were analysed by using an inductive approach, in which data collected from unstructured interviews, observation and document reviews was organised, categorised and analysed using content analysis technique in order to identify the proposed system requirements (Achievability, 2018). Finally, the findings were compared to other secondary sources to come up with effective methods on how to develop the proposed system.

3.7 System Development Approach

During the system development, this study employed a Rapid Application Development (RAD) as a software development methodology, as shown in Fig. 5. This model was adopted was chosen because it emphasises frequent developer-customer communication and early delivery of the product due to limited timeframe (Dawson, Burrell, Rahim & Brewster, 2010; Hirschberg, 2018).

After the system requirements were collected, the design and development phases were performed in iterative stages while stakeholders were frequently contacted for each stage to ensure that the end product meets end users' expectations.

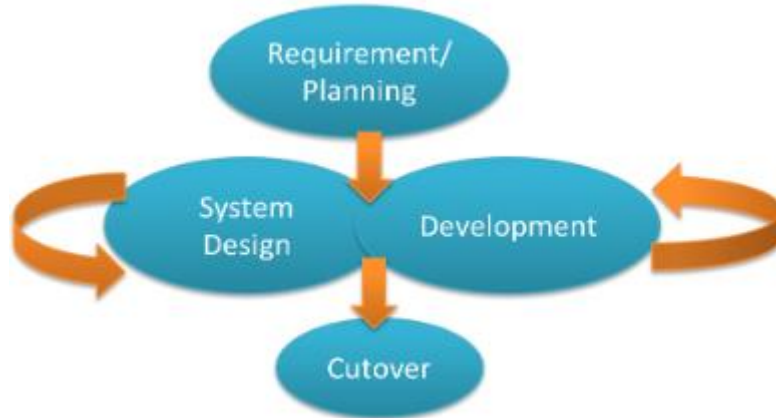

Figure 5: Rapid Application Development (RAD) lifecycle (Daassnet, 2018)

3.8 System Modelling

During the development phase, system modelling was used to define the functionalities and interactions between different processes within the system while reducing the complexity of the descriptions. System modelling involves mapping system functional requirements into graphical languages based on the Unified Modelling Language (UML) rules. The system was modelled and described by using UML tools such as Use Case diagrams, Flowchart diagrams and Data Flow diagrams (Aschwanden-Granfelt & Sved, 2017).

3.9 System Implementation

During the implementation of the system, different hardware tools, software tools and languages were used. This includes the selection of relevant hardware equipment for prototype development, data transmission unit, database management system and the web application. These methods and tools are described in the following subsections:

3.9.1 Smart Meter Unit

The main components of the smart meter unit were selected by considering the design criteria established during the collection of system requirements. These design criteria were efficiency, accuracy, cost and device compatibility issues. Since the proposed system was designed based on the local market, cost and efficiency were the main design criteria during

the implementation of the system. The embedded software was written in C/C++ libraries by using the Arduino Integrated Development Environment (IDE) (Louis, 2016).

3.9.2 Database Server

The system database was developed by using My-Structured Query Language (MySQL). This is an open-source database management system that is used for data definition, storage and manipulation. In this study, MySQL was used since it is a free, open-source, has got tremendous technical support and runs on multiple operating systems (Letkowski, 2014).

3.9.3 Server-Side Applications

Server-Side applications are used for handling client requests, information flow and database access to the remote server (Vishesh *et al.*, 2017). Hypertext Preprocessor (PHP) is the most popular server-side scripting language that is used by a large number of web applications (Botwe & Davis, 2015). It is open-source software that supports a wide range of database systems with the ability to concurrently connect to multiple databases without compromising the database security (Supaartagorn, 2011). In this study, PHP was used as a server-side scripting language between the web application and the MySQL database (Hills & Klint, 2014). This language was selected because it has got large community support that makes improvements to the language libraries and frameworks every day. Moreover, it is also easy to integrate PHP with MySQL database to provide services to the clients (Crawford & Hussain, 2017)

3.9.4 Client-Side Applications

Client-Side Applications are used to provide user-friendly interfaces to the clients. The client-side interfaces were developed by using Hypertext Mark-up Language (HTML), Cascading Style Sheet (CSS) and JavaScript languages. A combination of these languages makes a client-side web application dynamic and interactive to the user (Rajesh & Srikanth, 2014). In addition to that, JQuery and Ajax libraries were used for presenting dynamic data to the client-side interface without requiring page refresh (jQuery Foundation, 2019).

3.9.5 JavaScript Object Notation (JSON)

The communication between smart meter units and the cloud server was achieved through Hypertext Transfer Protocol (HTTP) messages. Transmitted data is encapsulated by using

JavaScript Object Notation (JSON) which is an open standard data interchange format used to transmit data between clients and server (Mozilla Developer Network, 2019).

3.10 System Testing and Validation

System testing involved three phases, unit testing; integration testing and system testing. Unit testing involves testing the functionality of a single module before integrating with other modules. Integration testing was performed when integrating more than one module to eliminate any logical or syntax errors before proceeding to the next module. Finally, system testing was performed by using black-box testing methodology to ensure that the developed system performs all the necessary functionalities as defined during requirement gathering (Sawant, Bari & Chawan, 2012). Lastly, system validation was carried out by using Alpha and Beta testing approach (Mohd & Shahbodin, 2015). Alpha testing was performed by involving five mini-grid company staff. Finally, beta testing was carried out by involving a potential group of 25 consumers for a period of seven days.

3.11 Assumptions and Dependencies

The development of the two-way electricity usage monitoring system for decentralised mini-grids was based on the following assumptions:

- (i) Mini-grid centres consist of only single-phase power distribution system for domestic applications. The system, therefore, does not cover electricity usage monitoring for three-phase large power customers such as industries, machines and irrigation centres.
- (ii) The cloud-server has got enough resources such as data storage space, processing power and the ability to efficiently retrieve and provide services to the client applications.
- (iii) The cloud-server uptime is 99%, except during maintenance and upgrading times
- (iv) The area around the mini-grid data centre has a good GPRS network coverage
- (v) All consumers have good knowledge of using and accessing web services provided via the internet
- (vi) All consumers have or will afford to possess a smartphone, computer or tablet.

CHAPTER FOUR

RESULTS AND DISCUSSION

4.1 Introduction

This chapter discusses findings from data collected in the study area, requirements formulation, system designing and development. The chapter also discusses in-depth the correspondence between findings and research objectives. The first objective was to gather requirements for developing a web-based electricity monitoring platform for decentralised solar mini-grids. This also includes consumers' awareness and their perception regarding the proposed system. The second objective was to develop a web-based two-way electricity usage monitoring system for decentralised solar mini-grids. The third objective was to validate the developed system.

4.2 Findings from the Consumers

Consumer data were collected to determine the extent of the problem and whether the proposed system would be a relevant solution. A total of 106 respondents participated in this study.

4.2.1 Demographic Information

Since the study focuses primarily on consumer awareness of the access and significance of electricity usage monitoring systems, it is important to consider demographic characteristics among the potential users of the system. The demographic characteristics which were considered in this study were gender, age and education level attained. These characteristics are very significant in assessing the usability of the proposed energy monitoring system.

Out of 106 respondents, 69 were males, while 37 were females. The majority of the respondents were aged between 20 and 50 years, which represents 77.4% of the sample size. Approximately 50% of respondents' have reached the secondary education level. Table 2 shows the demographic characteristics of all respondents.

Table 2: Demographic information of consumers

Demographic characteristic		Respondents	Percentage (%)
Gender	Male	69	65.1
	Female	37	34.9
Age (in Years)	Less than 20	2	1.9
	20-29	20	18.9
	30-39	43	40.6
	40-49	20	18.9
	50-59	16	15.1
	60 and above	5	4.7
Education	Non-formal education	3	2.8
	Primary education	45	42.5
	Secondary education	41	38.7
	Tertiary education	17	16.0

4.2.2 Consumers' Access to ICT Services

Out of 4000 people in the two study areas, a total of 106 respondents were involved during data collection. These are the families whose houses had already been connected to the mini-grids power supply. Among the 106 respondents, only 6.2% do not own any ICT communication tool, while 54.1% possess feature phones which cannot access the internet. The remaining 39.7% had at least a communication device which is capable of accessing the internet. This information is illustrated in Fig. 6(a). By using these ratios it can be estimated that, out of the 4000 population, at least 1500 people do possess smart devices which can access internet services.

Furthermore, information regarding how frequently people access the internet was collected, showing that about one-third of all consumers access the internet on a daily basis, as indicated in Fig. 6(b).

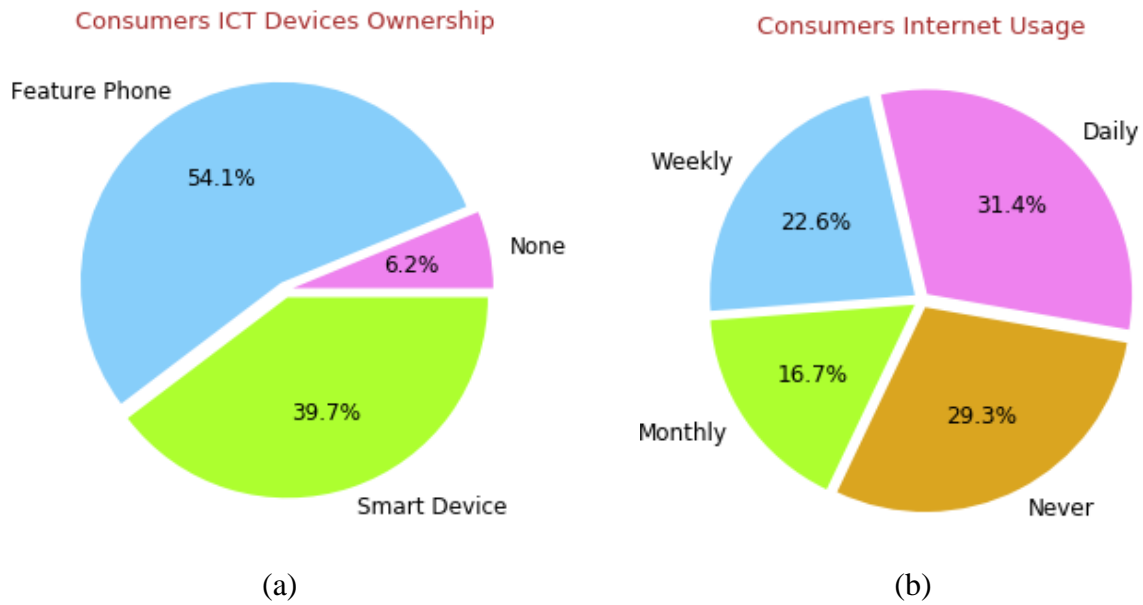

Figure 6: Consumers ICT devices ownership and internet usage

4.2.3 Consumers' Electricity Usage Behaviour

Out of 106 respondents, 17.9% stated that they use electricity for lighting only while 45.3% used for lighting and charging of mobile phones. The remaining 36.8% use electricity for several domestic activities in addition to lighting and charging of electronic devices. This information is well summarised in Fig. 7. As time goes on the demand for electricity will increase such that majority of the people will need information regarding their usage so that they can adjust their usage behaviour in order to couple with the growing electricity bills.

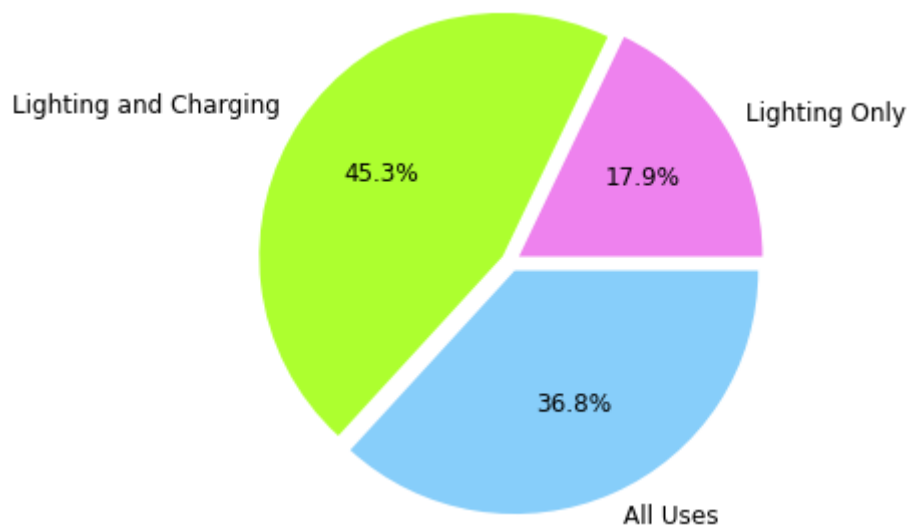

Figure 7: Consumers' electricity usage behaviour

4.2.4 Consumers' Awareness to Electricity Usage Information

Out of 106 respondents, only 0.9% were fully aware of their electrical devices' power consumption information. The majority of the respondents do not have a clue about information regarding electrical power consumption of their equipment as shown in Fig. 8.

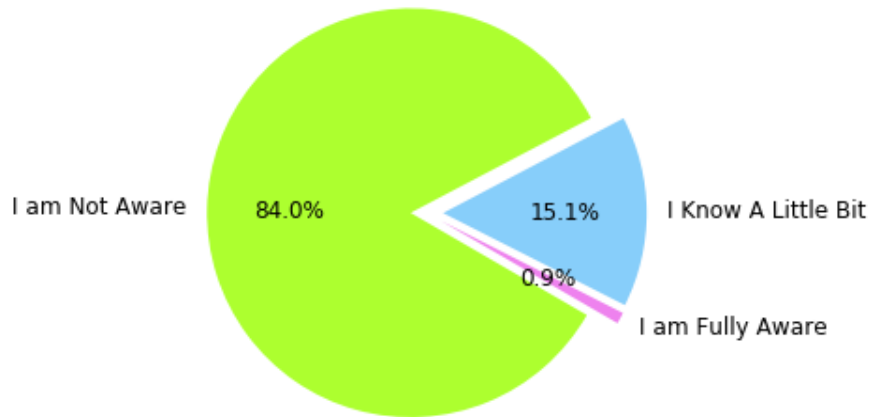

Figure 8: Consumers' awareness of electricity usage information

4.2.5 Consumers' Perception on the Need for Having Electricity Usage Monitoring System

Of the 106 respondents, 89.5% agreed that it would be helpful to have a web portal to track their electricity usage information. Furthermore, 7.1% suggested a mobile application which can be installed into their smartphones, while 3.4% of the respondents stated that they were not sure how the system could be useful to them. Figure 9 summarises this information.

The Need for Online Platform for Accessing Electricity Usage Information

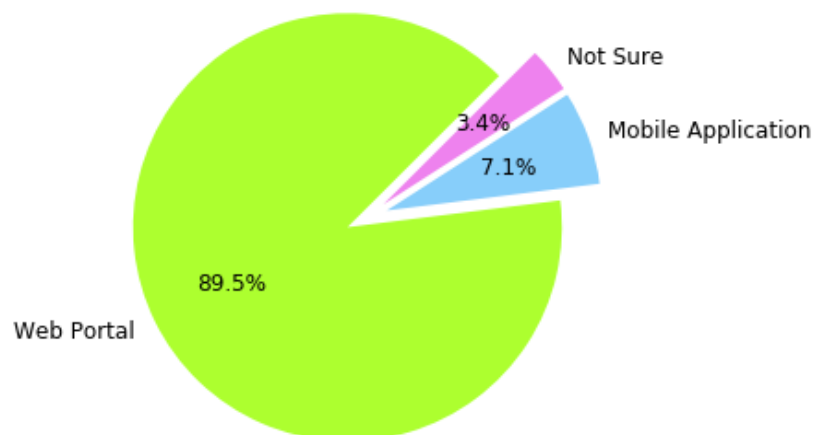

Figure 9: Consumers' perception of the need for the electricity usage monitoring system

4.2.6 Consumers' Recommendations on the System Requirements

In this study, system requirements were partly collected from consumers, who are the potential beneficiaries of the proposed system. Table 3 shows the requirements collected from respondents, whereas it appeared that, after requirements analysis, the majority of respondents preferred the system to be able to show the remaining credits, show power consumption records and send SMS notification when credits are about to get exhausted.

Table 3: Consumers' recommendations on the system requirements

Requirement	Respondents
User-friendly interface (a menu displaying only the key options such payment link, historical usage link and customer support link)	39
Information about the remaining credits	63
Information about monthly energy records	31
SMS notification when credits are about to exhaust	27
Customer support	19
User privacy and security	8
Online bill payment	11

4.3 Findings from the Mini-Grid Company

This study also collected information from the mini-grid company, where four utility staff were involved. The information aimed at assessing technical information on how to improve the current monitoring system in mini-grid centres. Data was collected through unstructured interviews, discussions, participatory observation and document reviews.

4.3.1 Information Collected from the Mini-Grid Centres

The information from the two mini-grid centres is described below:

(i) Mkalama Solar Power Project

Mkalama solar mini-grid centre shown in Fig. 10 is located in Mkalama village at Hai District in Kilimanjaro region, about five kilometres from Bomang’ombe suburb. The installed solar plant can produce a maximum of 10 kW electrical power at a time. At the centre there are 64 solar Photo-Voltaic (PV) panels, 32 batteries and a pair of 7.5 KVA inverters. As of August 2019, the station is supplying electricity to 83 households. The area has a reliable coverage for GSM/GPRS and 3G cellular network communication from at least four network service providers.



Figure 10: Mkalama solar mini-grid centre

(ii) Ngurdoto Solar Power Project

Ngurdoto solar mini-grid centre shown in Fig. 11, is located in Ngurdoto village at Arumeru District in Arusha region, about three kilometres from Maji ya Chai suburb. The installed solar plant can produce a maximum of 10 kW, having 32 solar PV panels, 10 storage batteries and a pair of 7.5 KVA inverters. As of August 2019, the station is supplying electricity to 57

households. More than four network service providers provide cellular network coverage for GSM, GPRS, 3G and 4G at the study area.



Figure 11: Ngurdoto solar mini-grid centre

4.3.2 Mini-grid Company's Recommendations on the System Requirements

System requirements were also collected from the utility company's technical staff and from reviewing other similar electricity usage monitoring systems. Since the system proposed is a two-way communication model, the system requirements collected from both sources have been analysed and combined to form an integrated conceptual framework. These requirements are shown in Table 4.

Table 4: Mini-grid company recommendations on the system requirements

Requirement	Description
Monitored Parameters	The system should monitor current, voltage and compute kilowatt-hour units from each smart meter, which in addition to meter ID, will be sent to the cloud server for storage, analysis and visualisation.
Users' Registration and Users' Accounts Management	All consumers must be registered by the system administrator or any of the authorised staff, with the system providing each with the username and password.
Data Visualisation	The system should provide historical power consumption data visualisation in a graphical format. The system also should provide the flexibility for choosing different time ranges for historical data viewing.
Security	The system should be secured. Consumption data and consumers' information should only be disclosed to the system users. The system should authenticate all system users before allowing them to interact with system functionalities.
Usability	Users with different levels of computer literacy should be able to interact with the system easily. System interfaces and modules should therefore only provide the necessary functionalities that its users can easily navigate.
Accessibility	By utilising the existing cellular networks, the system should be accessible anytime and anywhere.

4.4 System Modelling

The design phase of the proposed system relied on the following design criteria; cost, usability and efficiency. Low-cost was achieved by selecting equipment and tools with enough minimum requirements while ensuring that they can be purchased at a low price. In addition, communication infrastructure has been designed to use only one GPRS gateway to connect to the cloud server remotely. Usability accounts for the system's ability to provide only basic functionality so that its target users can easily utilise it. Efficiency stands for the ability of the system to provide the intended output with minimum resources and time, including the ability to transfer data and cloud server with minimum packet loss or latency.

4.4.1 System Design Architecture

The system incorporates the application of the Internet of Things (IoT) to record and monitor each customer's power consumption information and sends data to the cloud server. The conceptual framework consists of smart meters, LPWAN, GPRS gateway and the cloud server. The functionalities of each component is explained below:

- (i) **Smart Meter Units:** Smart meters are installed at consumer houses to record electrical parameters; current, voltage and compute kilowatt-hour units.
- (ii) **LoRa Modules:** Each smart meter is fixed with LoRa modules which create a private wide area network around the mini-grid area. These modules communicate with the local server at the mini-grid monitoring centre.
- (iii) **GPRS Gateway:** Data from smart meters is transmitted to the cloud server by utilising the existing cellular networks through the GPRS gateway.
- (iv) **Cloud Server:** The cloud server, which comprises of a database, application server and SMS gateway provides both storage space and application files which handle all data access procedures to and from the database.

Figure 12 illustrates a conceptual framework for the proposed web-based two-way electricity monitoring system for decentralised solar mini-grids.

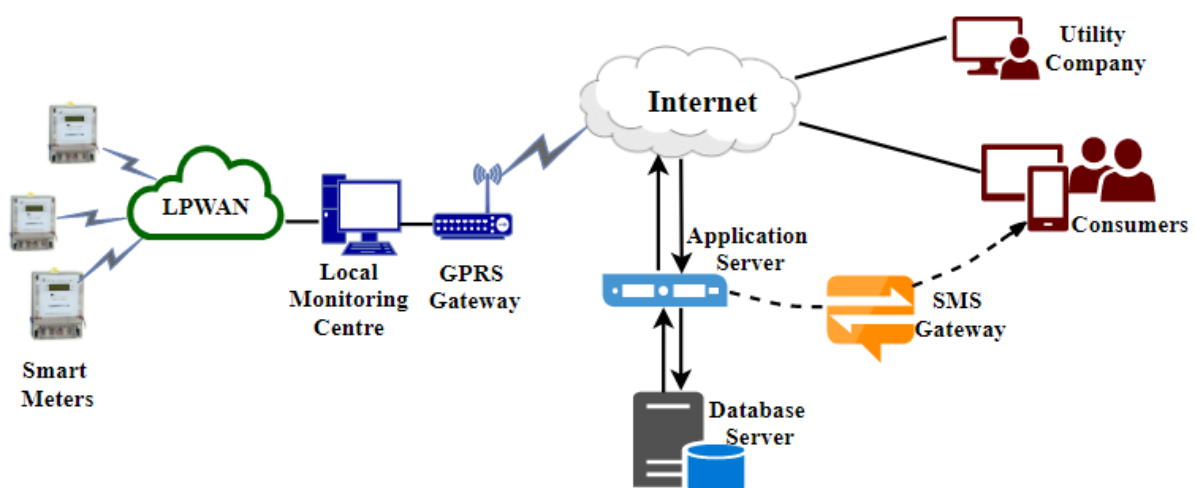

Figure 12: Conceptual framework of the proposed system

4.4.2 Smart Meter Unit

The design phase started with the embedded part of the system, which consists of smart meter unit and the communication unit. Figure 13 shows the block diagram of the smart meter unit.

The smart meter unit has been designed to ensure that it can have three main features:

- (i) Ability to measure and record power consumption accurately.
- (ii) Ability to be remotely connected or disconnected by a utility company.
- (iii) Cost-effective communication with the remote server.

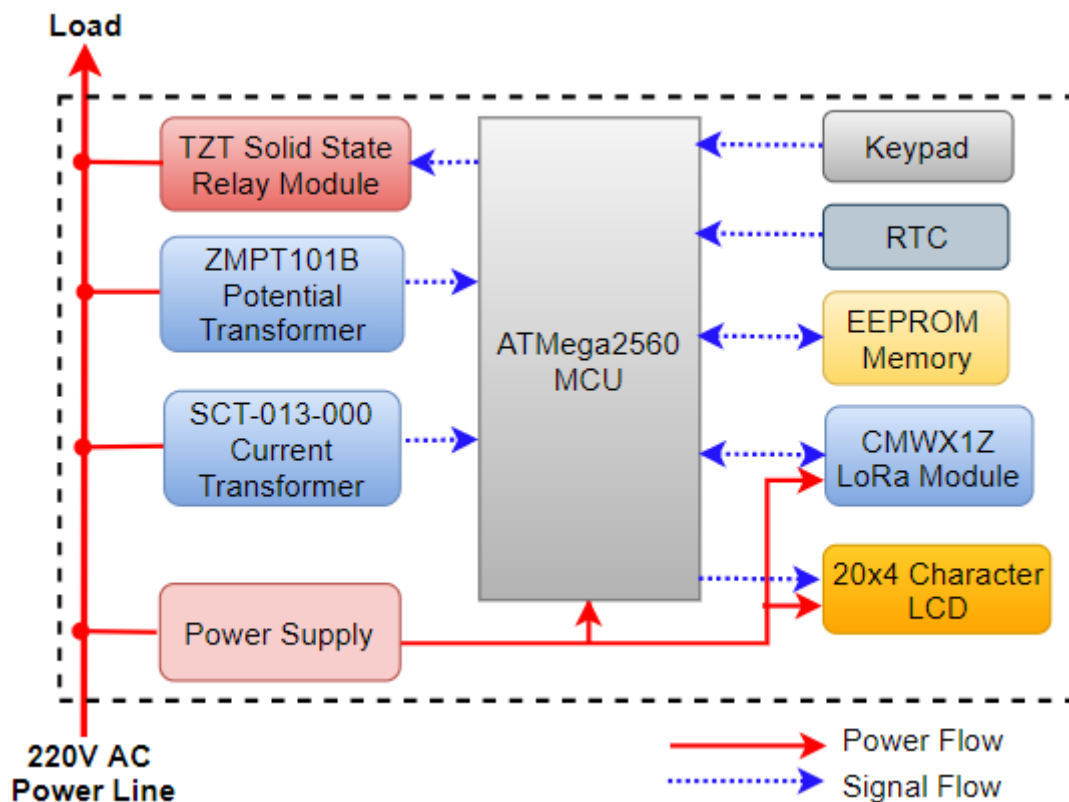

Figure 13: Smart meter unit block diagram

The main components of the smart meter are described in the following subsections.

(i) Power Measurement Unit

Power measurement unit consists of current and voltage sensors. The current sensor is made up of a non-invasive split-core SCT-013-000 current transformer which can withstand current of up to 100 A. This module was selected because of its broad current range measurement and flexibility in cabling, as it does not require direct contact with the power cable. Voltage sensor consists of a ZMPT101B single-phase voltage transformer which can withstand up to

250 AC voltage. This module was selected due to its high accuracy and comes with a built-in trim potentiometer for adjusting the ADC output (Abubakar, Khalid, Mustafa, Shareef & Mustapha, 2017). Figure 14 illustrates the current and voltage transformers used in this study.

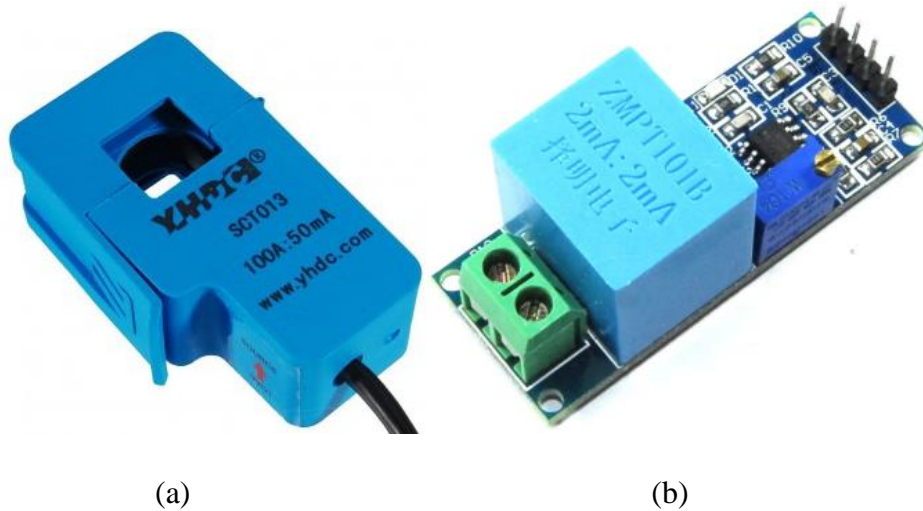

Figure 14: Current transformer and voltage transformer (Surtr Technology, 2019)

(ii) Relay Module

The relay module acts as a bridge for controlling high voltage circuit from the low voltage circuit. The relay module is used to perform remote switching operations to connect and disconnect the power supply to the consumer. This is because the 5 V microcontroller circuit cannot directly control the 220V consumer load line. In this study, the TZZT solid-state relay module as shown in Fig. 15 is used to remotely control the connection from the utility line to the consumer line.



Figure 15: Solid-state TZZT relay module (Hackster, 2019)

(iii) LCD Screen

The LCD screen is used to display power consumption information to the local user, particularly when the communication between the local server and cloud server is not stable. The necessary information displayed on the screen includes current, voltage, consumed power and the remaining credits. In this study, an LCD2004 20X4 character module as shown in Fig. 16 was used for smart meter local display unit.

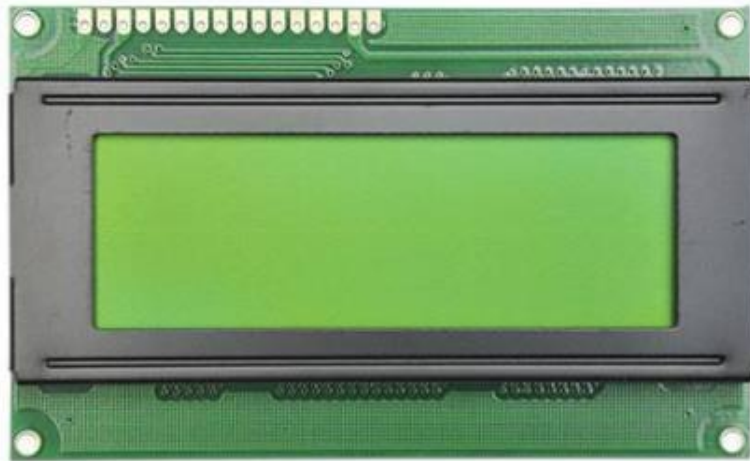

Figure 16: 20 by 4 character LCD screen (Winstar, 2019)

(iv) Real-Time Controller (RTC)

In embedded systems and IoT applications, the RTC is an integrated circuit (IC) which is used to keep the precise time and date of sensor measurements and microprocessor operations to synchronise with the absolute reference time (Barai, Krishnan & Venkatesh, 2016). RTC can be part of the microprocessor IC or an external module connected to the microprocessor via a serial interface. In this study, an external DS1307 RTC module as shown in Fig. 17 was selected because it has a built-in backup battery which enables it to track time even when there is no primary power supply.

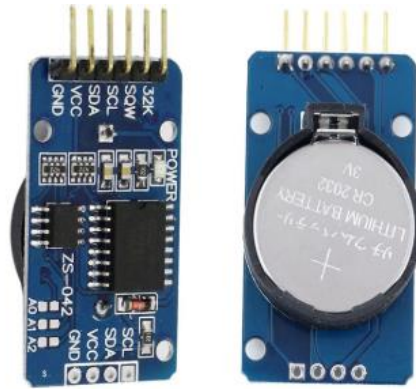

Figure 17: DS1307 Real-time clock module (ElectronicWings, 2018)

(v) Microcontroller Unit

The efficiency of the microcontroller largely depends on the efficiency of three components; current transformer, voltage transformer and microprocessor unit. The assessment was conducted to determine the suitable microcontroller board for the proposed system by considering four factors; cost, processing capacity, memory and easy of configuration.

A total of 3 microcontroller boards as shown in Fig. 18 were identified as potential microcontroller boards for the smart meter unit. A comparative assessment of these microcontroller boards is shown in Table 5. After thorough analysis, the Arduino-based ATmega2560 microcontroller board was selected due to its low cost, enough processor processing capacity, while having a large number of built-in ADC inputs.



Figure 18: Atmega2560, Raspberry Pi and Nucleo-F410re microcontroller boards

Table 5: Comparative assessment of potential microcontroller boards for a smart meter

Device model	Arduino Mega	Raspberry Pi 3 Model B	Nucleo-F410re
Microcontroller	ATmega2560	ARM quad core	STM-32-ARM
Power	5V, 20mA	5V, 3.3V, 2A	5V, 800mA
Cost	Low	High	Low
Memory	512 KB	1 GB	512 KB
Processor speed	16 MHz	1.4 GHz	84 MHz
Strengths	Cheap A large number of analogue I/O pins Support availability	Built-in wireless connectivity Large processing power	Cheap
Limitation	No built-in wireless module	Expensive Needs external ADC modules for sensor inputs	Non-compatible pin-out arrangement Limited technical support

4.4.3 Data Transmission Unit

Consumption data from smart meters is transmitted to the local monitoring centre through a private Low Power Wide Area Network (LPWAN), which uses LoRa technology. Consumption data is then transmitted to the cloud server through the existing GPRS network. The LPWAN architecture was implemented by integrating CMWX1ZZABZ LoRa modules to a smart meter unit. These LoRa modules operate at the license-free bands of 433 and 868 MHz (Hackaday, 2018). These modules were selected due to their compact size and small power consumption. Figure 19 shows the LoRa chip used for data transmission between the smart meter unit and the local server, while Fig. 20 shows the flowchart diagram of the data transmission unit of the smart meter.



Figure 19: LoRa module used for data transmission (Hackaday, 2018)

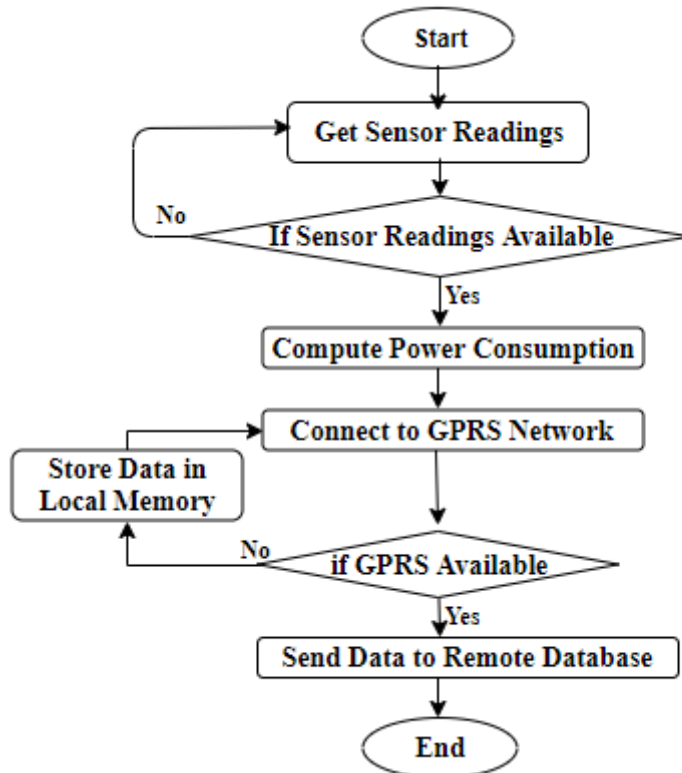

Figure 20: Flowchart diagram for data transmission unit

4.4.4 Web Application

The web application handles all information flow operations between system actors and the system database. This includes processing HTTP Request messages from the GPRS gateway to the database, user authentication, session managements and provision of data visualisation

to the clients. The web application was designed by using Use Case Diagram, Data Flow Diagram and Database Server.

(i) Use Case Diagram

Use case diagram depicts how the different actors interact with the system from the user point of view. Figure 21 shows the use case diagram used for the application server of the system. The system has three main actors, namely; Utility Company, Consumer and Smart Meter.

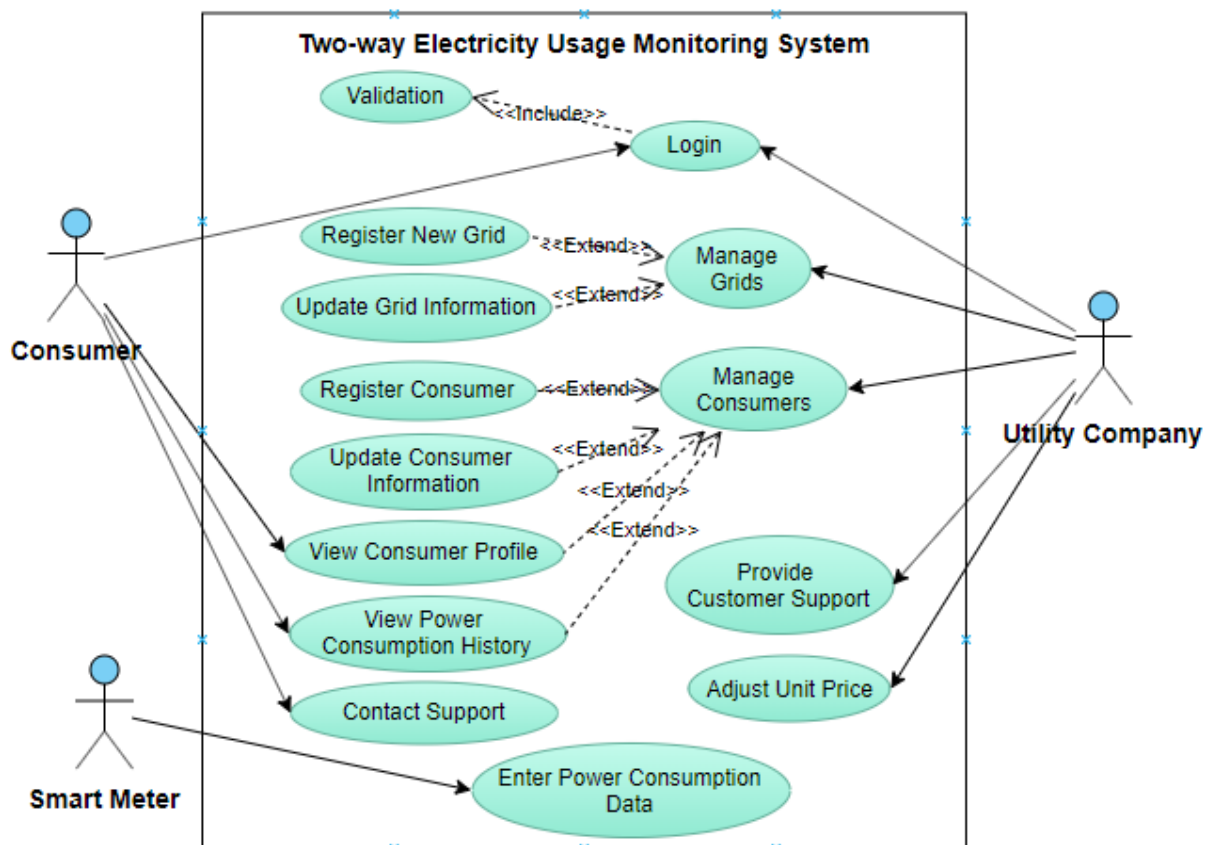

Figure 21: Use case diagram for the system's web application

(ii) Data Flow Diagram (DFD)

The Data Flow Diagram (DFD) as shown in Fig. 22 describes the flow of the information from between systems actors to the web application. The smart meter sends power consumption data to the cloud server, while at the same time requests information about the remaining credits. The web server can connect or disconnect the smart meter, depending on the status of the remaining credits. The consumer can access information about connection status, remaining credits or communicate with the utility company.

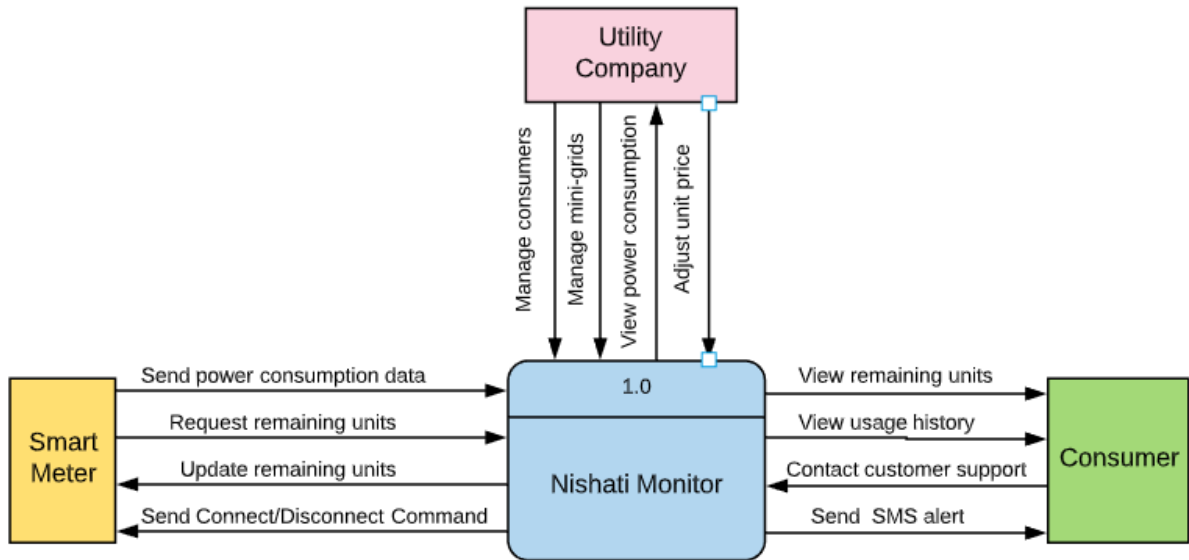

Figure 22: System data flow context diagram

(iii) Database Server

The database server was developed using the MySQL database management system. The database schema consists of seven tables whose attributes and relations are shown in Fig. 23.

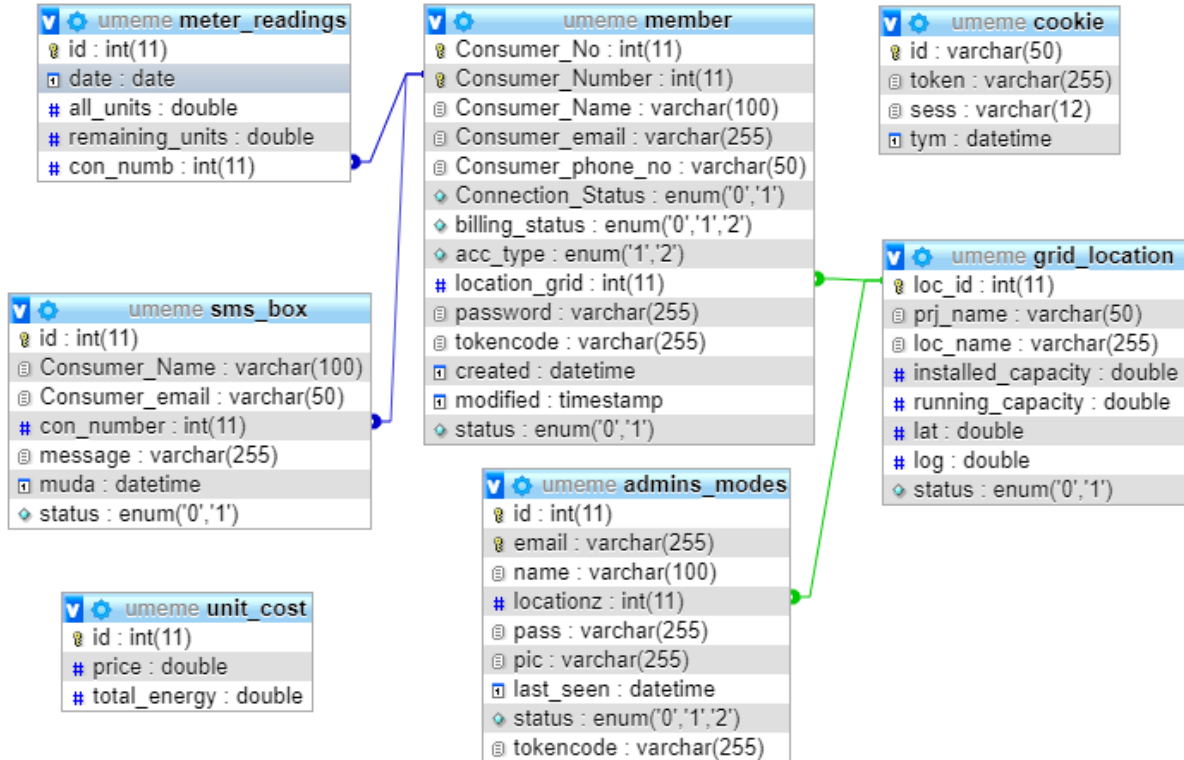

Figure 23: Web application database schema

4.5 System Implementation

4.5.1 Smart Meter Unit

Figure 24 shows a complete smart meter unit prototype during system testing. After testing, the smart meter unit was then enclosed into a plastic case as shown in Fig. 25.



Figure 24: Smart meter unit during system testing



Figure 25: Smart meter unit enclosed inside a waterproofing box

4.5.2 Data Transmission Unit

Power consumption data from the smart meter is transmitted to the local server at the mini-grid centre, which then communicates with the cloud server via a GPRS gateway. Several LoRa base station modules have been installed at the top of electric poles as shown in Fig. 26 to boost up the signal strength between smart meters and the local server at the mini-grid centre as shown in Fig. 27.



Figure 26: LoRa base station

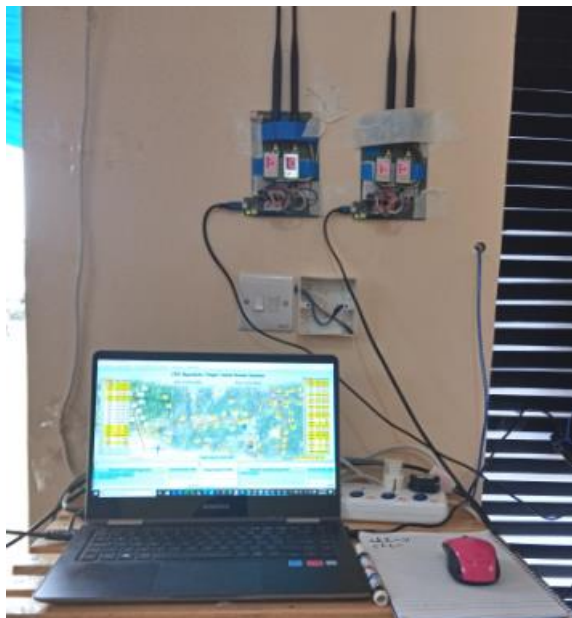

(a)



(b)

Figure 27: Local monitoring centre and the GPRS gateway

4.5.3 Developed Web Application

The web application for the electricity usage monitoring system has been designed to provide only the necessary functionalities suggested by stakeholders. The main functionalities provided by the web application includes grid and consumer data storage, data visualisation, user registration and authentication. The next subsections describe the main interfaces of the developed web application.

(i) User Authentication

To ensure the security of the developed system, only registered users will be allowed to log in to the system before accessing any information. Users will be provided with a default username and password. To ensure access level security, these passwords have been encrypted by using BCrypt algorithm, which is a PHP built-in one-way hashing algorithm. Figures 28 and 29 shows user authentication interfaces for the mini-grid system administrator and consumers, respectively.

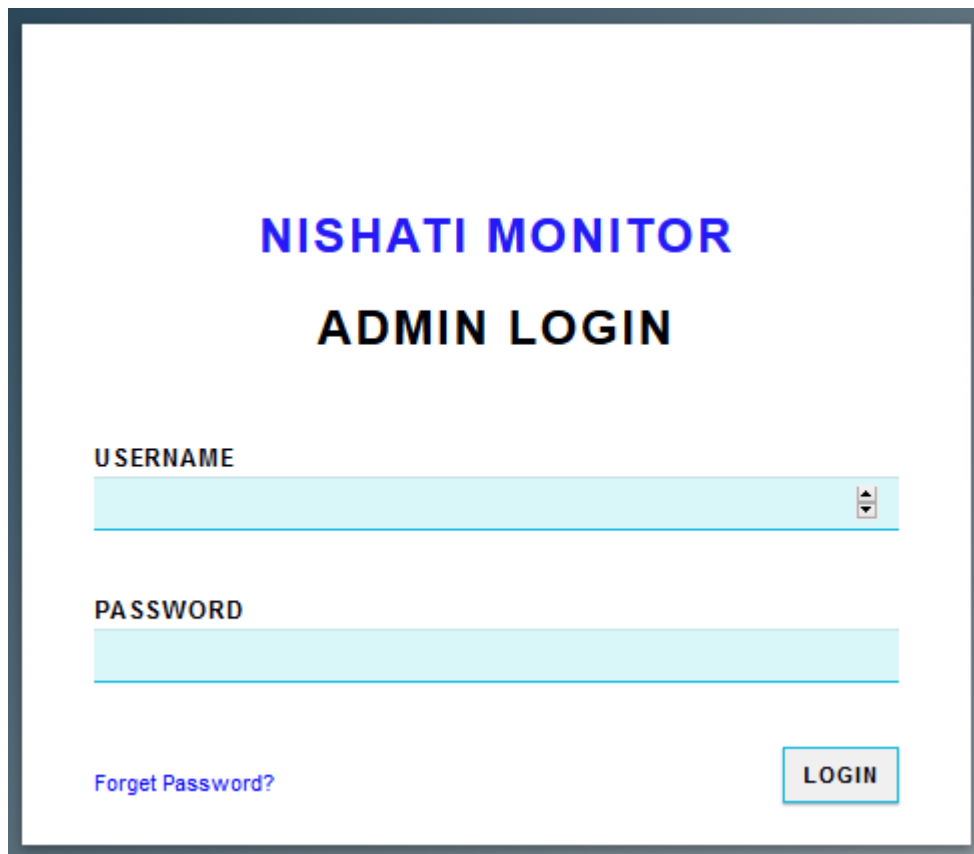

The image shows a web application login page for a system administrator. The page is titled "NISHATI MONITOR ADMIN LOGIN" in a large, bold font. Below the title, there are two input fields: "USERNAME" and "PASSWORD". The "USERNAME" field has a dropdown arrow on the right side. At the bottom left of the page, there is a link "Forget Password?". At the bottom right, there is a "LOGIN" button.

Figure 28: System administrator login page

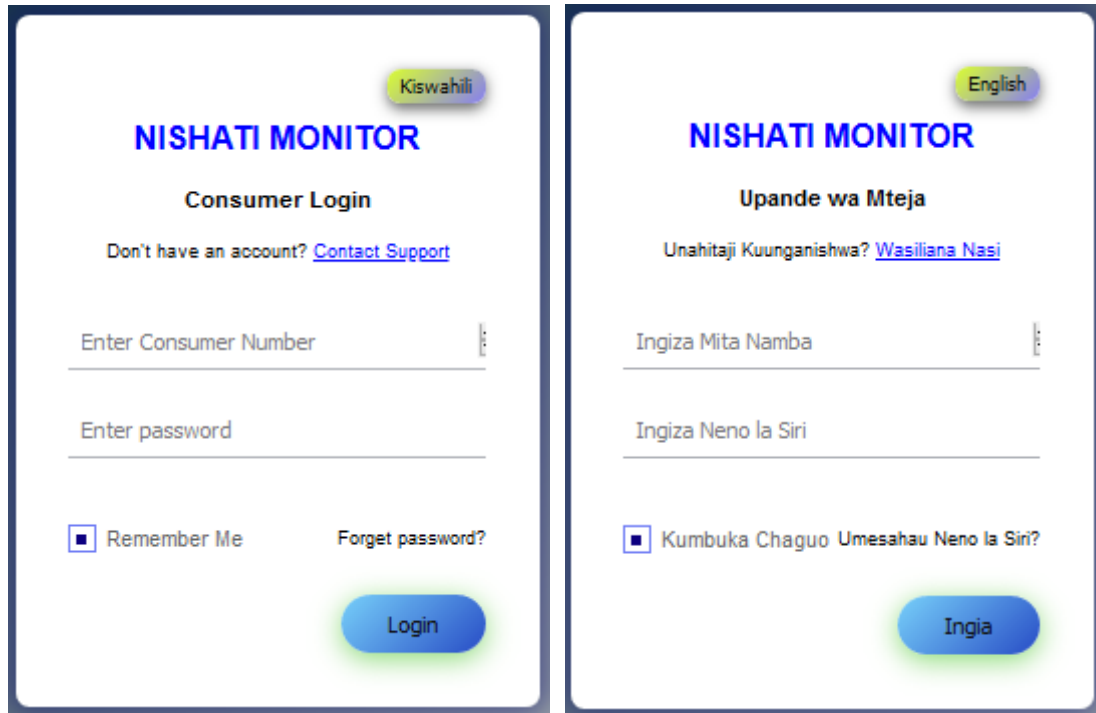

Figure 29: Consumer login page

(ii) Grid Power Consumption Dashboard

This interface is only accessible by the system administrator of the mini-grid company. The interface shows total energy consumption for each grid per month, as shown in Fig. 30. This information is useful for assessing grid production capacity versus demand for current and future planning purposes. From the graphical data, the following interpretation can be inferred:

- (a) The overall power usage trend for both mini-grids is increasing, as more customers are connected to the grid network as time goes on.
- (b) Although both mini-grids have the same power generation capacity, Ngurdoto's consumption data is relatively higher than Mkalama because of the difference in the number of connected consumers and the economic status of each region. Most Mkalama consumers use electricity primarily for lighting and charging, while Ngurdoto villagers use electricity for several economic activities.
- (c) The overall decrease in power consumption during May was attributed to the upgrade of battery and PV panels in both mini-grids, resulting in intermittent availability of power.

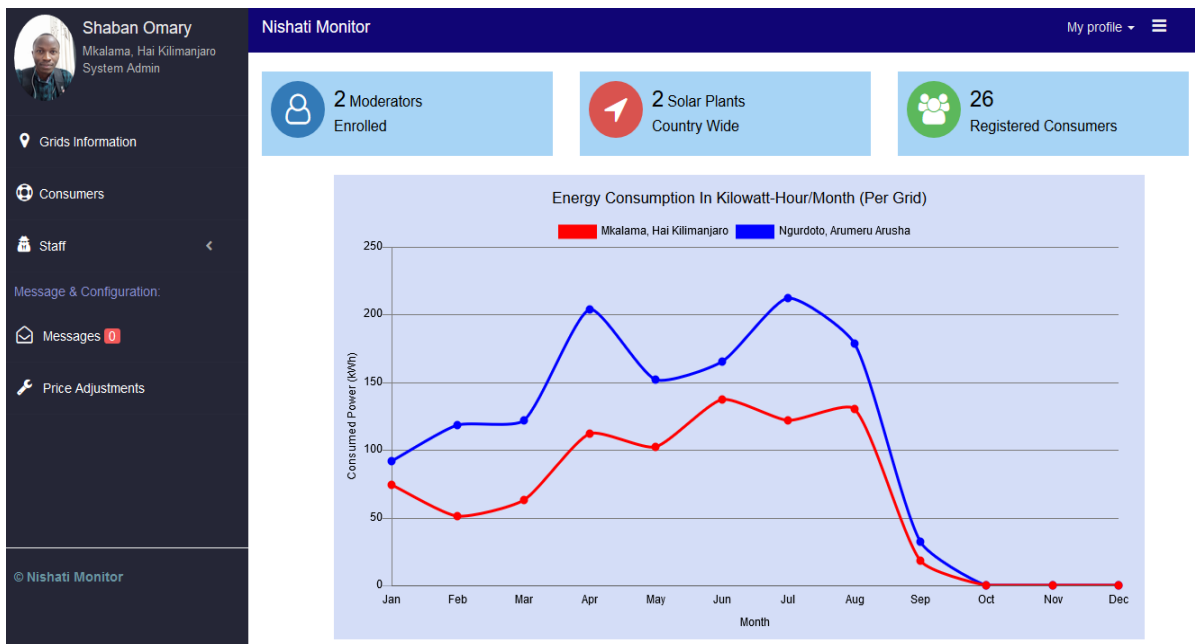

Figure 30: Grid power consumption dashboard

(iii) Mini-Grids Information Management

The purpose of mini-grid management is to provide the system administrator with the ability to register new mini-grid centres and updating the existing projects. Figure 31 shows the information of registered mini-grids, while Fig. 32 shows the interface for registering a new mini-grid centre.

Project Name	Location	Installed Capacity(kW)	Running Capacity(kW)	Number Of Connected Houses	GPS Coordinates	Actions
iTec Makalama Solar Center	Mkalama, Hai Kilimanjaro	10	5	12	Mkalama, Map Location	
iTEC Ngurdoto Solar Plant	Ngurdoto, Arumeru Arusha	10	10	13	Ngurdoto, Map Location	

Figure 31: Registered mini-grids

Register New Mini-Grid

View Registered Grids

Project Name:	<input type="text" value="ITec Plant"/>
Project Location:	<input type="text" value="District, Town"/>
Installed Capacity:	<input type="text" value="1.0"/>
Running Capacity:	<input type="text" value="1.0"/>
Latitude:	<input type="text" value="-3.00000"/>
Longitude:	<input type="text" value="36.00000"/>
<input type="button" value="Insert"/>	

Figure 32: Registration of a new mini-grid centre

(iv) Consumer Management

All consumers must be registered by the system admin or staff through the consumer management interface, as shown in Fig. 33. The system administrator can add new consumers, edit or suspend a consumer through a consumer management page which shows a list of all registered consumers.

Registered Consumers

Type by name or meter no:...

Consumer No:	Name	Location	Connection Status	Actions
13	Daniel Mwanga	Ngurdoto, Arumeru Arusha	<input checked="" type="checkbox"/>	<input type="button" value="View"/> <input type="button" value="Edit"/> <input type="button" value="Suspend"/>
14	Kato Mathias Iganiza	Ngurdoto, Arumeru Arusha	<input checked="" type="checkbox"/>	<input type="button" value="View"/> <input type="button" value="Edit"/> <input type="button" value="Suspend"/>
15	Damian Lewis Makame	Ngurdoto, Arumeru Arusha	<input checked="" type="checkbox"/>	<input type="button" value="View"/> <input type="button" value="Edit"/> <input type="button" value="Suspend"/>
16	Salimin Amour Majuto	Ngurdoto, Arumeru Arusha	<input type="checkbox"/>	<input type="button" value="View"/> <input type="button" value="Edit"/> <input type="button" value="Suspend"/>
17	Sabina Aidan Zakayo	Ngurdoto, Arumeru Arusha	<input checked="" type="checkbox"/>	<input type="button" value="View"/> <input type="button" value="Edit"/> <input type="button" value="Suspend"/>

First Page 1 2 3 4 Last Page

Figure 33: Consumer management interface

(v) Power Consumption Data Visualization

When the consumer successfully logged into the system, they are directed to their profile where information about the remaining credits and connection status is shown as illustrated in Fig. 34(a). Additionally, the consumer can view energy usage history, which is presented in a user-friendly graphical format, as shown in Fig. 34(b). By default, the interface shows usage history for the previous seven days. Furthermore, the interface also shows information about the total consumed credits and the corresponding cost for the specified period. By providing this information, consumers can make informed budget decisions that would help them to adapt their consumption behaviour to their economic status.

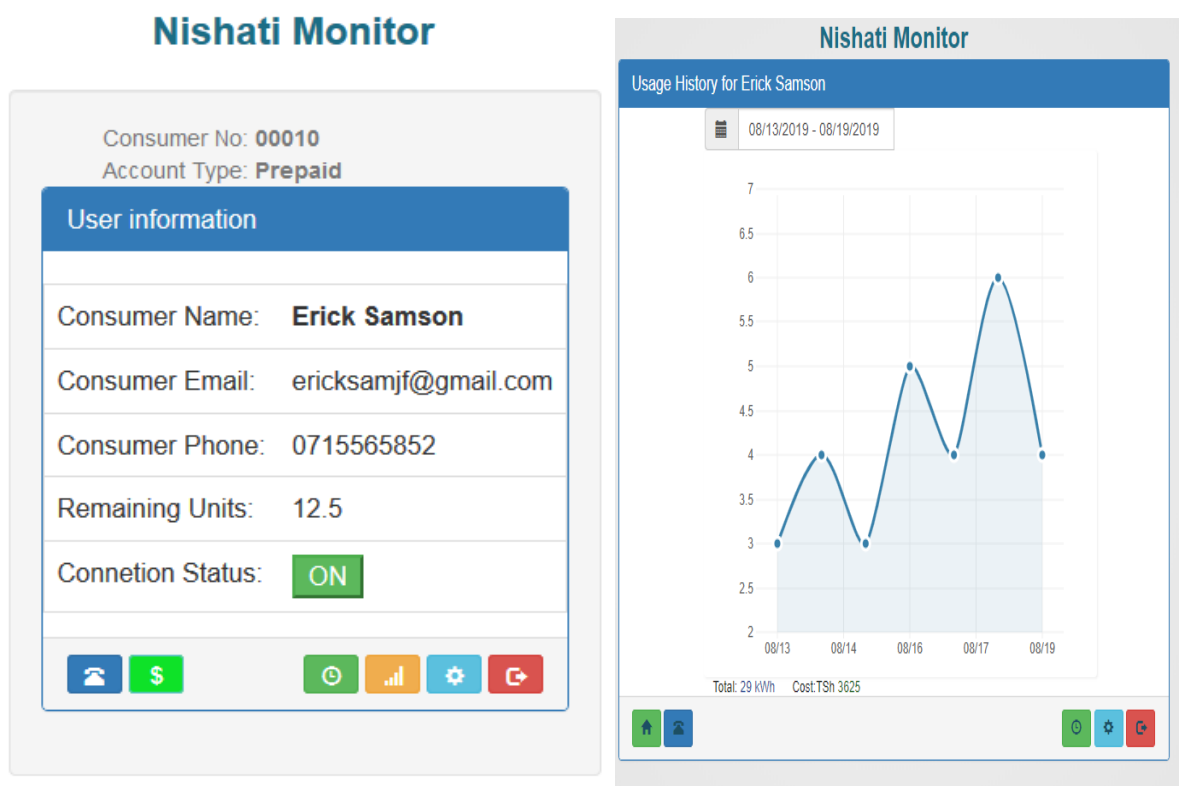

(a)

(b)

Figure 34: Consumer profile and electricity usage history

(vi) Usage Notification Unit

The notification algorithm periodically queries for the credits balance of the particular meter account. When credits become less or equal to some predefined amount, SMS notification is sent to the respective consumer. When credits become less or equal to zero, a DISCONNECT command is sent to the smart meter to disconnect power supply to the house.

Figure 35 shows the flowchart diagram of the notification algorithm while Fig. 36 shows SMS notification sent to the consumer. This feature is aimed to enhance consumer experience towards energy usage awareness so that consumers can make payment arrangements before power is disconnected.

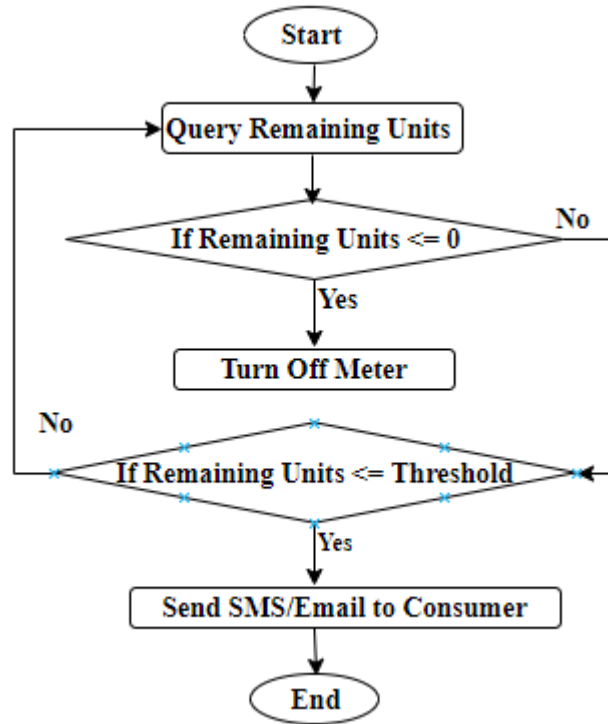

Figure 35: Notification algorithm flowchart diagram



Figure 36: Usage status notification SMS

(vii) Customer Support

The consumer interface also provides contact options for consumers to communicate with the customer support team by using different communication options such as phone call, email address and online form, as shown in Fig. 37.

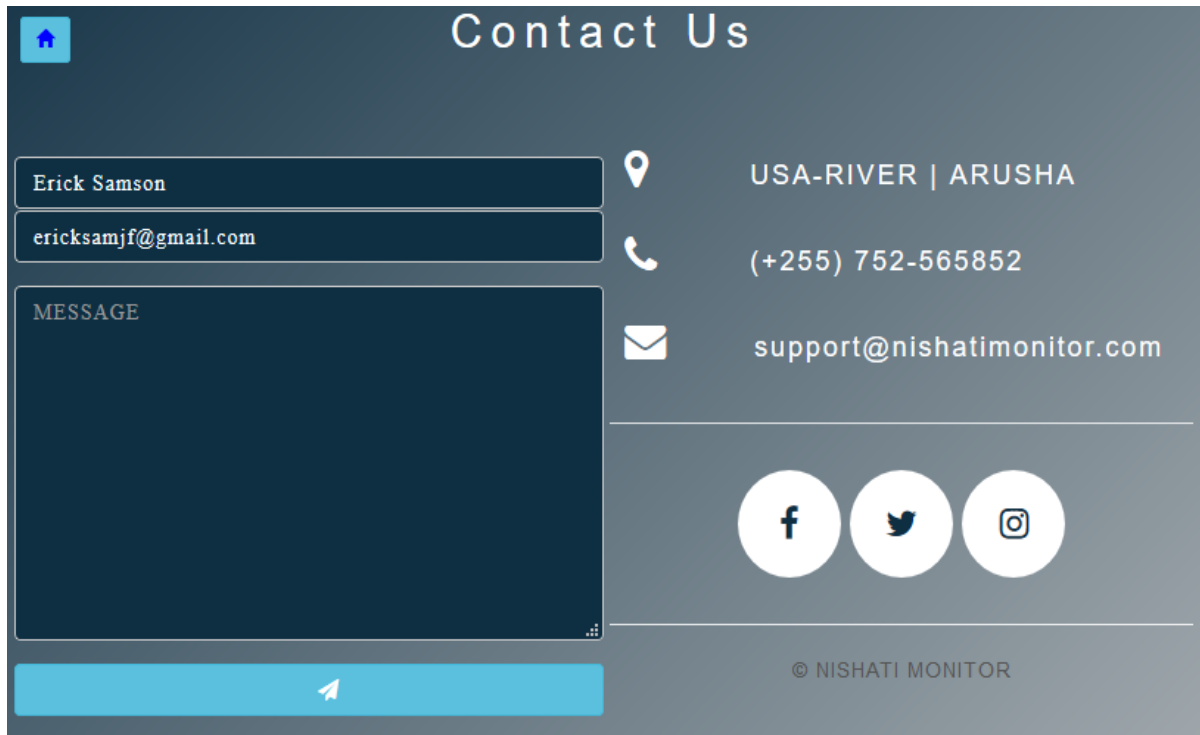

Figure 37: Customer support page

(viii) Electricity Units Prepayment System

This study was aimed to enhance equal access to power consumption information to stakeholders in decentralised solar mini-grids. Since the system requirements depend primarily on inputs from stakeholders, one of the stakeholders' recommendations was to integrate the monitoring system with the bill payment system. The current legal framework in Tanzania for tariff establishment in utility services requires that all tariff proposals have to be approved by EWURA before they become operational. However, in efforts to remove barriers in mini-grid investments, the revised SPP framework does not legally require regulatory approval of proposed retail tariffs for SPPs with an installed capacity of less than 100 kW (Pedersen, 2016). Therefore in this study, tariff adjustment is determined through the agreement between the utility company and consumers by considering investment capital, operating costs and average daily power consumption data at the mini-grid centre.

The proposed payment system uses mobile money services, the most popular payment method for utility services in Tanzania, in order to accommodate all consumer categories, those with and without access to the internet. When a consumer sends a payment request, the payment system uses a transaction message from Payment Gateway to generate a token whose units depend on the amount the consumer pays and the current unit price. The token message is sent back to the consumer for updating electricity units in their meter account.

Figure 38 shows information flow after the integration of monitoring system (Nishati Monitor) with a payment system (Omega Malipo), while Fig. 39 shows a sample of payment confirmation message sent to the consumer.

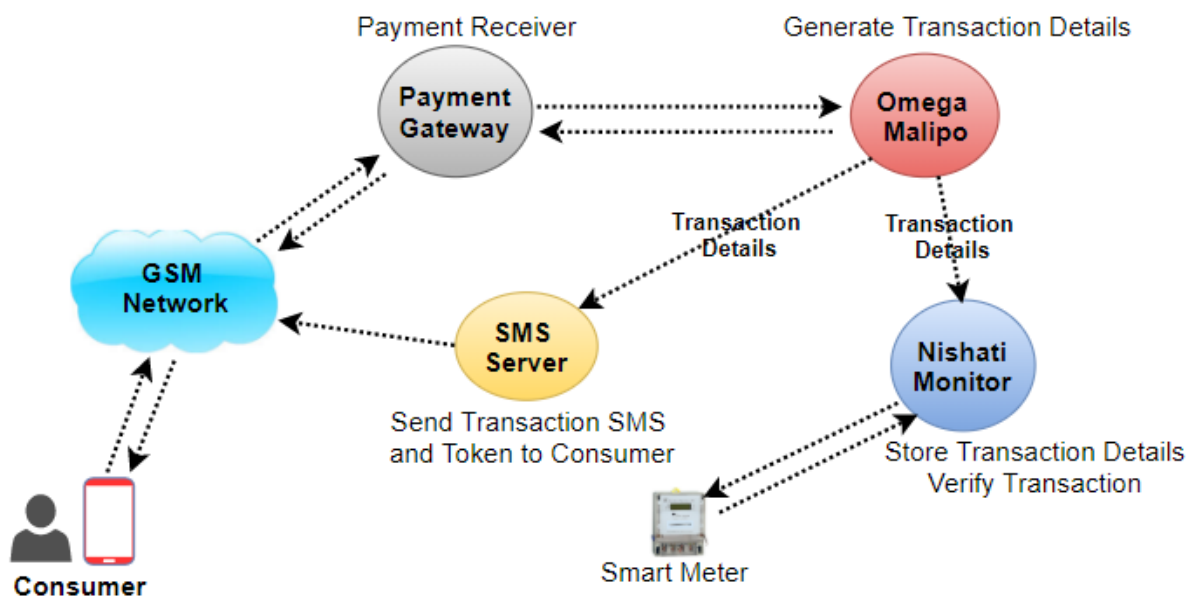

Figure 38: Integration between the payment system and monitoring system

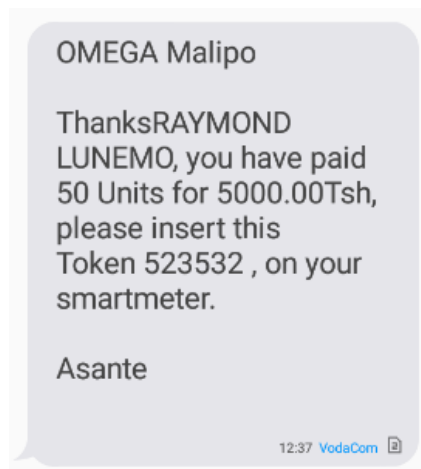

Figure 39: Payment confirmation message sent to the consumer

4.6 System Testing and Validation

After system development, unit testing was conducted to ensure that each system module is working correctly. System performance evaluation was subsequently carried out to determine the system's power consumption recording accuracy against several generic electrical appliances. Finally, user acceptance testing was carried out by involving a representative group of consumers.

4.6.1 Unit Testing

Unit testing was performed in the laboratory environment, where a smart meter prototype was used to check the performance of each system unit before integrating with other modules.

(i) Smart Meter Unit

Data acquisition unit, which consists of smart meter and communication modules, was tested to ensure that it measures, computes, display and send power consumption data to the cloud server. Table 6 summarises the tests performed under the data acquisition unit.

Table 6: Smart meter unit testing

System requirements	Results
The smart meter should measure current, voltage and computes kilowatt-hour units.	PASS
The smart meter should display current, voltage, power and remaining credits on a local display screen.	PASS
The smart meter should send consumption data to the server after every configured periodic interval.	PASS
When the network is unreachable, the smart meter should store consumption data on a local memory and sends it to the server when the network becomes stable again.	PASS

(ii) User Authentication Unit

This test aimed to check if a registered user can successfully log in and logout the web portal by using their username and password. Table 7 shows the results of this test.

Table 7: User authentication unit testing

System requirements	Results
The web portal should allow only registered users to log in and logout the system by using their usernames and passwords	PASS
The system should provide password recovery option for all registered users	PASS

(iii) Consumer Management

The objective of this test was to ensure if the system administrator can perform consumer management tasks, as described in Table 8.

Table 8: Consumer management unit testing

System requirements	Results
The system administrator should be able to register new consumers, view, suspend and edit information of registered consumers.	PASS
Each consumer should have a unique consumer number.	PASS

(iv) Grid Information Management

This test was intended to check if the system can handle information for more than one mini-grid centre since most of the mini-grid companies in Tanzania have multiple mini-grid centres around the country. The results are summarised in Table 9.

Table 9: Grid information management unit testing

System requirements	Results
The system administrator should be able to add new mini-grid information, view and edit the current mini-grids information, including power capacity, location and operating status.	PASS
The system administrator should be able to view the map of the specific mini-grid centre	PASS

(v) Consumer Profile Information

This test aimed to test if consumers can view their profile information, connection status, remaining credits and get SMS notification on critical usage status. Table 10 summarises the results of this test.

Table 10: Consumer profile information unit testing

System requirements	Results
The system should display consumer profile information, which consists of a consumer name, meter number, contact information, connection status and remaining credits. This information should be displayed after a successful login to the system.	PASS
For security reasons, the consumer should be able to edit their profile information before contacting the customer support staff.	PASS
The system should provide users with options to contact the support team	PASS
The system should send SMS to the consumer when remaining credits are less than the predefined threshold	PASS

(vi) Energy Visualization Data

This test was intended to check if consumers can view their electricity usage records in a user-friendly interface which in addition to graphical data presentation, it shows total cost associated with the selected timeframe. Test results are summarised in Table 11.

Table 11: Energy visualization unit testing

System requirements	Results
The system should display electricity usage history through a user-friendly graphical format.	PASS
The system should display associated cost and consumed credits for each energy usage history shown on the graph.	PASS
The system should allow the consumer to select different timeframes to view electricity usage history.	PASS

4.6.2 System Performance Test

The system performance test was conducted to assess the accuracy of the system to record and store power consumption data for a specified period. To perform this test, several electrical appliances with known power ratings were connected to the load side of the smart meter prototype and the operating time was recorded.

The majority of electrical appliances have power rating information indicating how much electricity they will consume when operating, which is usually given in Watts (W) or kilowatts (kW). However, the standard unit for computing the amount of electricity consumed by an appliance for a given period is expressed in kilowatt-hours (kWh). From this theory, the expected electricity consumption data by a given electrical appliance was computed and compared to the system's recorded data to assess the performance of the system. The test results from the three appliances are shown in Table 12.

Table 12: System performance test results

Device power rating (Watts)	Running time (Hours)	Expected units (kWh)	Recorded units (kWh)	Error (%)
220	21	4.620	4.4496	3.8.3
60	3.42	0.205	0.1958	4.72
1500	0.075	0.1125	0.1080	4.15

The results above show that the system was able to record the amount of electrical energy consumed by electrical appliances within the acceptable 5% error range, indicating that the system performance is satisfactory.

4.6.3 Acceptance Testing

After the system prototype was tested by the internal staff of the utility company, it was taken to the field to collect consumers' perceptions on system usability. Twenty-five people participated in this activity. The survey responses were collected on a five-point Likert scale having scale responses of Strongly Disagree = 1, Agree = 4, Not Sure = 3, Disagree = 2 and Strongly Disagree = 1 (Lozano, García-Cueto & Muñiz, 2008).

Table 13 shows the system acceptance test results. From the table, the mean score for each response was above 3.50, which is falling within the Agree response, implying that the majority of respondents were satisfied with the overall system performance and usability.

Table 13: System acceptance testing responses

Acceptance parameter	Number of respondents					Mean Score
	Strongly Disagree	Disagree	Not Sure	Agree	Strongly Agree	
The system's interfaces are easy to use and interact with	0	0	0	14	11	4.44
There are no compatibility issues between the system and different web-browsers/ devices	0	0	15	7	3	3.52
I do not need further training and assistance on how to fully navigate to different system interfaces	0	6	0	8	11	3.96
The system will help consumers access their electricity usage information and raise awareness on electricity usage behaviour	0	0	0	6	19	4.76
The system provides a convenience method for communicating with company's customer support	0	0	0	11	14	4.56
I am satisfied with the overall system performance	0	0	0	17	8	4.32
I will recommend others to use this system	0	0	2	14	9	4.28

4.7 Findings and Discussion

The following are the main findings collected during the period of conducting this study:

- (i) **LoRa technology is a convenient solution for deploying private WAN if cost and power consumption are the main design criteria**

For IoT application which require installation of wireless sensor network nodes at large distances, instead of using the legacy cellular networks, LoRa technology provides the optimum solution because it uses low power to transmit the same information over large distances. This is an important feature particularly for battery powered IoT devices which

needs to run under low power conditions. Furthermore, in addition to using unlicensed spectrum, a private LoRa network can save extra costs which would be incurred from using cellular networks since it removes the need for paying data plans to the network service providers.

(ii) People are not really interested in real-time data visualization, historical data suffice the need

During system validation, it was found that majority of the respondents were not really paying attention to the real-time power consumption data from the smart meter. Access to historical power consumption data was a big satisfaction for the majority of them. This means that, even when packet transmission delays occur, which affects real-time data transmission, customer experience would not be affected to a large extent since they will still be able to access historical power usage.

(iii) Usage notification was the most accepted feature of the system

The ability of the system to notify consumers about their power usage status especially when units are about to get finished was the most accepted feature during system validation. Most of the respondents agreed that this feature will help people to be aware about their usage status so that they can plan for bill payment before the units are completely exhausted.

CHAPTER FIVE

CONCLUSION AND RECOMMENDATIONS

5.1 Conclusion

This study aimed to improve the adoption of internet access in Tanzania to raise consumer awareness of the economical utilisation of electricity. The study focused on solar mini-grids systems due to their significance in providing electricity to community areas out the national grid network and due to lack of cost-effective monitoring systems. The study evaluated the current mini-grid systems and found that one of the research gaps is limited access to information about electricity consumption to the stakeholders. After collecting and analysing the awareness, perceptions and recommendations of people on having a two-way platform to access power electricity consumption information, both functional and non-functional system requirements were established. From those requirements, the study came out with the web-based two-way electricity usage monitoring platform for decentralised solar mini-grids in Tanzania.

This study was guided by three interrelated research questions. The answers for each research question are discussed below:

(i) What are the expectations of people on having an online platform for accessing are electricity consumption information?

The study found that existing power consumption monitoring systems in these mini-grids are one-way communication systems such that only the utility company can access electricity consumption data from smart meters connected to the mini-grid. The study also found that most people are not aware of their daily power consumption behaviour due to the lack of a user-friendly platform to access such information.

It was also been found that access to ICT services, particularly the internet, is becoming increasingly popular, so that most people can afford to own smartphones, tablets and computers. Also, survey results indicate that most respondents strongly agreed that there is a need for having a user-friendly platform to link power utility companies and customers for efficient utilisation of energy resources.

(ii) What are the system requirements and the right methodologies for developing a two-way electricity usage monitoring system for decentralised mini-grids?

The system requirements were collected from consumers, mini-grid company and from other secondary sources such as related research papers and reports. Among the critical features needed by the consumers include information about the remaining credits, electricity usage history and the associated cost. Also, many respondents suggested that the system should incorporate SMS alerts to notify users when the remaining credits are about to get exhausted.

In order to minimise operating costs, it was suggested to use a LoRa technology for deploying a private monitoring network around the mini-grid centres. In addition to that, stakeholders of the proposed system were frequently involved during system development to in order to ensure that only the necessary features recommended during requirement gathering were incorporated.

(iii) How will the proposed system be validated to ensure that it meets end-users' expectations?

The system design and development phases were centred towards achieving end-users' expectations. The web portal was designed to provide only necessary information as much as recommended by the end-users. Acceptance testing results show that the majority of people were comfortable with using their ICT devices to access information about how they utilise electricity.

After system development, acceptance testing was conducted by involving potential stakeholders of the proposed system. Firstly, alpha testing phase was performed where a five people from the mini-grid company participated during in-house testing of the system and their comments were used to improve some features before going to the consumers.

Finally beta acceptance testing was performed where 25 potential consumers were involved. The system was allowed to collect power consumption data from consumers for a period of 7 days and they were allowed to give out their recommendations on the system performance.

This study has laid the benchmark that could be used to provide both theoretical and practical insight for future works, particularly for the implementation of large projects towards enhancing stakeholders' access to electricity usage information in decentralised grid systems.

5.2 Recommendations

Based on the findings gathered, this study recommends the adoption of web-based two-way electricity usage monitoring systems by utility companies to increase awareness to the consumers towards economical electricity usage. This will not only help utilities to manage their mini-grid centres effectively but also will facilitate consumer involvement for the sustainability of the mini-grid business. The system will also help consumers to adjust their power usage behaviour to align with their financial constraints.

The scope of this study was to improve monitoring systems, access to consumption data and consumer involvement in decentralised solar mini-grid centres in Tanzania. Similar research work can also be extended to other power sources such as biomass, wind and geothermal energy, although these technologies are still underdeveloped in Tanzania compared to solar-powered sources.

Moreover, the government should encourage the utilisation of the fast-growing ICT to enhance access to data related to utility services between companies and consumers. The internet is progressively becoming more accessible and affordable to the majority of the community. People should use the internet not only for social networks, but also to access useful information about the utility services they use. In this information age, the internet is one of the most useful technologies; web-based systems provide a convenient and uniform platform for linking utility companies to consumers.

REFERENCES

- Abubakar, I., Khalid, S. N., Mustafa, M. W., Shareef, H., & Mustapha, M. (2017). Calibration of ZMPT101B voltage sensor module using polynomial regression for accurate load monitoring. *ARPN Journal of Engineering and Applied Sciences*, 12(4), 1076–1084.
- Achievability. (2018). How to Effectively Carry Out a Qualitative Data Analysis. Retrieved September 12, 2019, from <https://www.achievability.co.uk/evasys/how-to-effectively-carry-out-a-qualitative-data-analysis>.
- Ahlborg, H., & Hamma, L. (2011). Drivers and barriers to rural electrification in Tanzania and Mozambique. *World Renewable Energy Congress*, 2493–2500. Retrieved from <https://ideas.repec.org/a/eee/renene/v61y2014icp117-124.html>.
- Alahakoon, D., & Yu, X. (2016). Smart Electricity Meter Data Intelligence for Future Energy Systems: A Survey. *IEEE Transactions on Industrial Informatics*, 12(1), 425–436. <https://doi.org/10.1109/TII.2015.2414355>.
- Aschwanden-Granfelt, S., & Sved, A.-C. (2017). Process Flow Documentation A Flowchart Guide For Micro & Small Business Title: Process Flow Documentation Supervisor. Retrieved from <https://www.theseus.fi/bitstream/handle/10024/125035/StephanAschwanden-Granfelt.pdf>.
- Ashna, K.; Sudhish, G. (2013). GSM Based Automatic Energy Meter System with Instant Billing. *International Journal of Advanced Research in Electrical, Electronics and Instrumentation Energy*, 65–72. Retrieved from <https://www.semanticscholar.org/paper>.
- Barai, G. R., Krishnan, S., & Venkatesh, B. (2016). Smart metering and functionalities of smart meters in smart grid - A review. *2015 IEEE Electrical Power and Energy Conference: Smarter Resilient Power Systems*, 138–145. <https://doi.org/10.1109/EPEC.2015.7379940>.
- Barman, B. K., Yadav, S. N., Kumar, S., & Gope, S. (2018). Energy Utilization in Smart Grid. *2018 2nd International Conference on Power, Energy and Environment: Towards Smart Technology*, 2–4. Retrieved from <https://ieeexplore.ieee.org/document/8658501>.
- Beigh, N. T. (2019). Review on Smart Electric Metering System Based on GSM / IOT. *Asian*

- Journal of Electrical Sciences*, 8(1), 1-6. Retrieved from <https://www.researchgate.net/publication/330358185>.
- Botwe, D. A., & Davis, J. G. (2015). International Journal of Computer Science and Development Technologies Using Open Source A Comparative Study of Web Development Technologies Using Open Source and Proprietary Software. *International Journal of Computer Science and Mobile Computing*, 4(2), 154–165.
- Cattani, M., Boano, C. A., & Römer, K. (2017). An experimental evaluation of the reliability of lora long-range low-power wireless communication. *Journal of Sensor and Actuator Networks*, 6(2). <https://doi.org/10.3390/jsan6020007>.
- Chaplin, D., Mamun, A., Protik, A., Schurrer, J., Vohra, D., Bos, K., ... Cook, T. (2017). Grid Electricity Expansion in Tanzania: Findings from a Rigorous Impact Evaluation. *Mathematica Policy Research*. Retrieved from <https://www.mathematica.org/ourpublications-and-findings>.
- Chattopadhyay, D., Bazilian, M., & Lilienthal, P. (2015). More power, less cost: Transitioning up the solar energy ladder from home systems to mini-grids. *Electricity Journal*, 28(3), 41–50. <https://doi.org/10.1016/j.tej.2015.03.009>.
- Cohen, I. (2014). Mobile for Smart Energy Solutions. Retrieved from https://www.gsma.com/mobilefordevelopment/uploads/MECs2014_PROOF008_Single.pdf.
- Crawford, T., & Hussain, T. (2017). A Comparison of Server Side Scripting Technologies. *International Conference Software Engineering Research and Practice*, 69–76. Retrieved from <https://csce.ucmss.com/cr/books/2017/LFS/CSREA2017/SER3291.pdf>.
- Daassnet SRL. (2018). Software Design and Development. Retrieved October 10, 2019, from <http://www.daassnet.com/new/index.php/en/professionalservices/d-d.html>.
- Dawson, M., Burrell, D. N., Rahim5, E., & Brewster, S. (2010). Integrating Software Assurance into the Software Development Life Cycle (SDLC). *Journal of Information Systems Technology and Planning*, 3(6), 49–53. Retrieved from <http://citeseerx.ist.psu.edu/viewdoc/download?doi=10.1.1.668.9372>.
- Dipolelo Moime. (2016). Mobile technology as a key enabler in Africa’s growth. Retrieved April 29, 2019, from <https://vc4a.com/blog/2016/05/30/mobile-technology-as-a-key->

enabler-in-africas-growth.

- El Brak, M., & Essaaidi, M. (2012). Wireless sensor network in smart grid technology: Challenges and opportunities. *2012 6th International Conference on Sciences of Electronics, Technologies of Information and Telecommunications*, 578–583. <https://doi.org/10.1109/SETIT.2012.6481976>.
- ElectronicWings. (2018). Sensors Modules Real Time Clock Rtc Ds1307 Module | Sensors Modules. Retrieved November 10, 2019, from <https://www.electronicwings.com/sensors-modules/real-time-clock-rtc-ds1307-module>.
- Garcia, F. D., Marafão, F. P., Angelino De Souza, W., & Pereira Da Silva, C. (2017). Power Metering: History and Future Trends, 29–30. <https://doi.org/10.1109/GreenTech.2017.10>.
- Global Statistics. (2018). Desktop vs Mobile vs Tablet Market Share Africa | StatCounter Global Stats. Retrieved April 29, 2019, from <http://gs.statcounter.com/platform-market-share/desktop-mobile-tablet/africa>.
- Hackaday. (2018). Project Hackable CMWX1ZZABZ (LoRa) Devices. Retrieved November 11, 2019, from <https://hackaday.io/project/35169/logs>.
- Hackster. (2019). Measure Any AC Voltage Up to 250V - Hackster.io. Retrieved November 10, 2019, from <https://www.hackster.io/SurtrTech/measure-any-ac-voltage-up-to-250v-1af7bd>.
- Hanid, M. (2014). Design Science Research as an Approach to Develop Conceptual Solutions for Improving Cost Management in Construction. Retrieved from https://usir.salford.ac.uk/id/eprint/32050/1/Final_Thesis.pdf.
- Harper, M. (2014). Review of Strategies and Technologies for Demand-Side Management on Isolated Mini-Grids. *Lawrence Berkeley National Laboratory (LBNL)*, 3, 1–26. Retrieved from <https://escholarship.org/uc/item/0wc020br>.
- Hartvigsson, E., Ehnberg, J., Ahlgren, E., & Molander, S. (2015). Assessment of load profiles in minigrids: A case in Tanzania. *Proceedings of the Universities Power Engineering Conference*, 15, 1–5. <https://doi.org/10.1109/UPEC.2015.7339818>.
- Hassan Mir, S., Ashruf, S., Bhat, Y., & Beigh, N. (2019). Review on Smart Electric Metering

- System Based on GSM/IOT. *Asian Journal of Electrical Sciences*, 8(1), 1–6. Retrieved from www.trp.org.in.
- Hills, M., & Klint, P. (2014). PHP AiR: Analyzing PHP systems with Rascal. *2014 Software Evolution Week - IEEE Conference on Software Maintenance, Reengineering, and Reverse Engineering*, 454–457. <https://doi.org/10.1109/CSMR-WCRE.2014.6747217>.
- Hirschberg, M. A. (2018). Rapid Application Development (RAD): A Brief Overview Rapid Prototyping. *Data Application Systems*, 2(1), 1–16. Retrieved from https://www.csiac.org/wpcontent/uploads/2016/02/1998_03_01_RapidApplicationDevelopment.pdf.
- International Energy Agency. (2018). Global Energy & CO2 Status Report: The latest trends in energy and emissions in 2018. 21–22. Retrieved from <https://www.iea.org/reports/global-energy-co2-status-report-2019>.
- Joshi, D. S. A., Kolvekar, S., Raj, Y. R., & Singh, S. S. (2017). IoT Based Smart Energy Meter. *Bonfring International Journal of Research in Communication Engineering*, 6, 89–91. <https://doi.org/10.9756/bijrce.8209>.
- jQuery Foundation. (2019). jQuery. Write less, do more. Retrieved October 10, 2019, from <https://jquery.com/>.
- Kamilaris, A., Trifa, V., & Guinard, D. (2010). Building Web-based Infrastructures for Smart Meters. *Buildings*, 5, 1–6. Retrieved from <http://www.vs.inf.ethz.ch/publ/papers/AndreasKamilaris-buildi-2010.pdf>.
- Khadar, A., Ahamed, J., Madanpalli, E., & Nagaraj, I. M. (2017). Research Advancements Towards in Existing Smart Metering over Smart Grid. *International Journal of Advanced Computer Science and Applications*, 5(8), 84-92. Retrieved from www.ijacsa.thesai.org.
- Kuzlu, M., Pipattanasomporn, M., & Rahman, S. (2014). Communication network requirements for major smart grid applications in HAN, NAN and WAN. *Computer Networks*, 67, 74–88. <https://doi.org/10.1016/j.comnet.2014.03.029>.
- Letskowski, J. (2014). Doing database design with MySQL. *Western New England University*, 6(1), 1–15. <https://doi.org/10.2147/CLEP.S45752>.

- Lloret, J., Tomas, J., Canovas, A., & Parra, L. (2016). An Integrated IoT Architecture for Smart Metering. *IEEE Communications Magazine*, 54(12), 50–57. <https://doi.org/10.1109/MCOM.2016.1600647CM>.
- Louis, L. (2016). Working Principle of Arduino. *International Journal of Control, Automation, Communication and Systems*, 1(2), 21–29. <https://doi.org/10.5121/ijcacs.2016.1203>.
- Lozano, L. M., García-Cueto, E., & Muñiz, J. (2008). Effect of the number of response categories on the reliability and validity of rating scales. *Methodology*, 4(2), 73–79. <https://doi.org/10.1027/1614-2241.4.2.73>.
- Mekki, K., Bajic, E., Chaxel, F., & Meyer, F. (2019). A comparative study of LPWAN technologies for large-scale IoT deployment. *ICT Express*, 5(1), 1–7. <https://doi.org/10.1016/j.icte.2017.12.005>.
- Mohd, C. K., & Shahbodin, F. (2015). Personalized Learning Environment: Alpha Testing, Beta Testing & User Acceptance Test. *Procedia - Social and Behavioral Sciences*, 195, 837–843. <https://doi.org/10.1016/j.sbspro.2015.06.319>.
- Mozilla Developer Network. (2019). Working with JSON - Learn web development MDN. Retrieved September 12, 2019, from <https://developer.mozilla.org/en-US/docs/Learn/JavaScript/Objects/JSON>.
- Odarno, L., Sawe, E., Swai, M., Katyega, M. J. J., & Lee, A. (2017). Accelerating Mini- Grid Deployment in Sub-Saharan Africa. Retrieved from <https://www.wri.org/publication/tanzania-mini-grids>.
- Palaniappan, S., Asokan, R., Bharathwaj, S., & Sujaudeen, N. (2015). Automated Meter Reading System - A Study. *International Journal of Computer Applications*, 116(18), 39–46. <https://doi.org/10.5120/20440-2783>.
- Palinkas, L. A., Horwitz, S. M., Green, C. A., Wisdom, J. P., Duan, N., Hoagwood, K., ... Northwest, K. P. (2016). Purposeful sampling for qualitative data collection and analysis in mixed method implementation research. *Dental Survey*, 44(12), 73. <https://doi.org/10.1007/s10488-013-0528-y.Purposeful>.
- Palit, D., & Kaushik, B. (2015). Regulating Off-grid Electricity Delivery: Exploring the Grey

- Areas. *Economic and Political Weekly*, 10(3), 40–52. Retrieved from <https://www.epw.in/journal/2015/10/special-articles/regulating-grid-electricity-delivery.html>.
- Papadopoulos, T. A., Kaloudas, C. G., Chrysochos, A. I., & Papagiannis, G. K. (2013). Application of narrowband Power-Line Communication in medium-voltage smart distribution grids. *IEEE Transactions on Power Delivery*, 28(2), 981–988. <https://doi.org/10.1109/TPWRD.2012.2230344>.
- Patil, K., Patil, S., Patil, S., & Patil, V. (2015). Monitoring of Turbidity, PH & Temperature of Water Based on GSM. *International Journal for Research in Emerging Science and Technology*, 2(3), 16–21. Retrieved from <https://ijrest.net/downloads/volume-2/issue-3/pid-ijrest-23201508.pdf>.
- Pedersen, M. B. (2016). Deconstructing the concept of renewable energy-based mini-grids for rural electrification in East Africa. *Wiley Interdisciplinary Reviews: Energy and Environment*, 5(5), 570–587. <https://doi.org/10.1002/wene.205>.
- Rajesh, C., & Srikanth, K. (2014). Research on HTML5 in Web Development. *International Journal of Computer Science and Information Technology*, 5(2), 2048–2412. <https://doi.org/ISSN:0975-9646>.
- Rob Gillies. (2017). Smart grid and smart meters: do we need them? Wiltshire Wildlife Community Energy. Retrieved from <http://wwce.org/what-is-the-smart-grid-and-why-do-we-need-it>.
- Saumu Jumanne. (2012). Tanesco falsified bills: adding salt to injury - The Citizen. Retrieved from <https://www.thecitizen.co.tz/oped/1840568-1815728-igrmxk/index.html>.
- Sawant, A. A., Bari, P. H., & Chawan, P. (2012). Software Testing Techniques and Strategies. *Journal of Engineering Research & Applications*, 2(3), 980–986. Retrieved from https://www.ijera.com/papers/Vol2_issue3/FQ23980986.pdf.
- Segatto, M. E. V., de Oliveira Rocha, H. R., Silva, J. A. L., Paiva, M. H. M., & do Rosário Santos, M. A. (2018). Telecommunication Technologies for Smart Grids: Total Cost Optimization. *Advances in Renewable Energies and Power Technologies*, 2, 451–478. <https://doi.org/10.1016/B978-0-12-813185-5.00007-3>.
- SmartSolar Tanzania. (2018). Solar Companies in Tanzania, SmartSolar Tanzania. Retrieved

September 11, 2019, from <http://www.smartsolar-tanzania.com/solar-sector-information/solar-companies-in-tanzania/>.

Supaartagorn, C. (2011). PHP Framework for Database Management Based on MVC Pattern. *International Journal of Computer Science and Information Technology*, 3(2), 251–258. <https://doi.org/10.5121/ijcsit.2011.3219>.

Supriya, S., Magheshwari, M., Sree Udhyalakshmi, S., Subhashini, R., & Musthafa, A. (2015). Smart grid technologies: Communication technologies and standards. *International Journal of Applied Engineering Research*, 10(20), 16932–16941.

Surtr Technology. (2019). Easy measure of AC Voltage using Arduino and ZMPT101B. Retrieved November 10, 2019, from <https://surtrtech.com/2019/01/21/easy-measure-of-ac-voltage-using-arduino-and-zmpt101b>.

Taghandiki, K., Zaeri, A., & Shirani, A. (2016). A Supervised Approach for Automatic Web Documents Topic Extraction Using Well-Known Web Design Features. *International Journal of Modern Education and Computer Science*, 8(11), 20–27. <https://doi.org/10.5815/ijmecs.2016.11.03>.

Tanzania Renewable Energy Association. (2019). Welcome Tanzania Renewable Energy Association. Retrieved October 11, 2019, from website: <https://www.tarea-tz.org/>.

Tanzania Communication Regulatory Authority (TCRA). (2019). April-June 2019 Operators Submissions. Retrieved from https://www.tcra.go.tz/images/TelCom_Statistics_June_2019.xlsx.pdf.

Techpoint Africa. (2018). How Africa's mobile revolution is generating unprecedented impact. Retrieved April 29, 2019, from <https://techpoint.africa/2018/10/23/africas-mobile-revolution-impact/>.

Ugonna, E. E., Ademola, A. K., & Olusegun, A. T. (2018). Design and construction of a smart electric metering system for smart grid applications: Nigeria as a case study. *International Journal of Scientific & Engineering Research*, 4(7), 800–804.

Unifonic. (2017). SMPP vs Restful API: which is best for you? Retrieved November 20, 2019, from <https://www.unifonic.com/Post/40191/SMPP-vs-Restful-API-which-is-best-for-you>.

- Vine, D., Buys, L., & Morris, P. (2015). The Effectiveness of Energy Feedback for Conservation and Peak Demand: A Literature Review. *Open Journal of Energy Efficiency*, 02(01), 7–15. <https://doi.org/10.4236/ojee.2013.21002>.
- Vishesh, S., Nandan, A., Kavya, P., Izharahmed, M., Gayathri, K., Keerthana, B., & Ganashree H. (2017). Server-Side and Client- Side Scripting of “Shutter Speed”. *International Journal of Advanced Research in Computer and Communication Engineering*, 6(9), 229–235. <https://doi.org/10.17148/IJARCCCE.2017.6942>.
- Weranga, K., Kumarawadu, S., & Chandima, D. (2013). Smart Metering Design and Applications. Retrieved from <http://www.amazon.ca/exec/obidos/redirect?tag=citeulike09-20&path=ASIN/9814451819>.
- Winstar. (2019). 20x4 Character LCD Display, 20x4 LCD Display, 2004 LCD Display - Winstar. Retrieved November 10, 2019, from <https://www.winstar.com.tw/products/character-lcd-display-module/20x4-lcd-display.html>.
- Wizara ya Nishati. (2019). Wizara ya Nishati – Jamhuri ya Muungano ya Tanzania. Retrieved October 2, 2019, from <https://www.nishati.go.tz/ks/>.
- World Resources Institute. (2018). Mapping Energy Access: Tanzania. Retrieved October 8, 2019, from: <https://www.arcgis.com/apps/MapJournal/index.html?appid=5e060dc63172439abae54bbed8a283fb>.
- Yu Energy. (2019). Smart VS AMR Meters: What Is The Difference?. Retrieved April 29, 2019, from <https://www.yuenergy.co.uk/news/smart-vs-amr-meters-what-is-the-difference>.

APPENDICES

Appendix 1: Questionnaire for Data Collection

Introduction

My name is **Shaban Omary**, a Master's student at the **Nelson Mandela African Institution of Science and Technology (NM-AIST)**, Arusha. The main objective of this questionnaire is to study the **needy** and **requirements** for developing an online-based platform that will enhance access to domestic electricity usage information in a user-friendly manner. The information collected in this questionnaire **will not** expose your identity by any means, and therefore feel free to give your opinions.

Section A: General information

1. What is your gender
 - a) Male
 - b) Female

2. What is our age?
 - a) Less than 20 years
 - b) 20 – 29
 - c) 30 – 39
 - d) 40 – 49
 - e) 50 – 59
 - f) 60 years and above

3. What is your education level?
 - a) No formal education
 - b) Primary
 - c) Secondary
 - d) Tertiary education

Section B: Access to ICT (communication) services

- 4. What kind of communication (ICT) devices do you possess?
 - a) None
 - b) Feature phone
 - c) Smartphone
 - d) Computer/Laptop
 - e) Others

- 5. How frequently do you use ICT services to access the internet
 - a) Daily
 - b) Weekly
 - c) Monthly
 - d) Less frequently
 - e) Never

Section C: Awareness towards domestic electricity usage

- 6. What kind of electrical equipment do you have? (Tick whichever apply)
 - a) Lights
 - b) Radio/TV
 - c) Fan
 - d) Fridge/Heater/Cooker/Blender
 - e) Electronics devices (Camera, Mobile Phone, Computer)
 - f) Others

- 7. What is your main daily electricity usage?
 - a) Lighting
 - b) Charging of mobile phone, computer and other electronic devices
 - c) Cooking and boiling
 - d) Cooling and Refrigeration
 - e) For operating Radio / TV
 - f) Others.....

8. How much are you aware of the electricity consumption behaviour of your domestic equipment?
 - a) Fully aware
 - b) Not much
 - c) Not at all
9. How do you access information regarding domestic electricity usage?
 - a) Not at all
 - b) Through a mobile phone
 - c) Through a consumer display unit
 - d) Through online platform
 - e) Others.....
10. Have you ever experienced a technical problem that needs assistance from electricity provider personnel?
 - a) Yes
 - b) No
11. If YES (question 10 above), how did you communicate with the responsible personnel?
 - a) Mobile phone call
 - b) Sending text message
 - c) Send an email
 - d) Wait until the personnel visit the house
 - e) Others
12. What kind of platform would you like to have for accessing electricity usage data?
 - a) Web portal
 - b) Mobile application
 - c) Not sure
13. If AGREE (question 12 above), what necessary features should the platform have?
 - a) Accessible through mobile phone
 - b) Accessible through laptop/computer
 - c) Accessible anytime and anywhere
 - d) Others

Appendix 2: Questionnaire for System Validation

Introduction

The main objective of this questionnaire is assessed to get users' feedback on the usefulness and performance of the developed web-based electricity usage monitoring system.

Respondent's position:

- a) System Administrator
- b) Customer

Please put a tick into the box corresponding to your perception of the developed system.

Acceptance Parameter	Strongly Disagree	Disagree	Not Sure	Agree	Strongly Agree
The system's interfaces are easy to use and interact with					
There are no compatibility issues between the system and different web-browsers/ devices					
I do not need further training and assistance on how to fully navigate to other system interfaces					
The system will help consumers access their electricity usage information and raise awareness on electricity usage behaviour					
The system provides a convenience method for contacting with company's customer support team					
I am satisfied with the overall performance of the system					
I will recommend others to use this system					

Appendix 3: Sample Arduino Codes for Smart Meter Unit

```
// include the library code:
#include <LiquidCrystal.h>
#include <math.h>
const int rs = 27, en = 26, d4 = 25, d5 = 24, d6 = 22, d7 = 23;
LiquidCrystal lcd(rs, en, d4, d5, d6, d7);
#include <Keypad.h>
const byte ROWS = 4; //four rows
const byte COLS = 4; //three columns
char keys[ROWS][COLS] = {
  {'1','2','3','A'},
  {'4','5','6','B'},
  {'7','8','9','C'},
  {'*','0','#','D'}
};
byte rowPins[ROWS] = {32, 33, 34, 35}; //connect to the row pinouts of the keypad
byte colPins[COLS] = {28, 29, 30, 31}; //connect to the column pinouts of the keypad
//byte rowPins[ROWS] = {28, 29, 30, 31}; //connect to the row pinouts of the keypad
//byte colPins[COLS] = {32, 33, 34, 35}; //connect to the column pinouts of the keypad
Keypad keypad = Keypad( makeKeymap(keys), rowPins, colPins, ROWS, COLS );
//Libraries for I2C
#include <Wire.h>
//Library for RTC
#include "RTClib.h"
//creating an object here
RTC_DS1307 rtc;
//CT and PT
#include "EmonLib.h" // Include Emon Library
EnergyMonitor emon1; // Create an instance
//system variables here
String KEY = "1234NM54"; //This is an API registered KEY from Online server, Get it from
server
```



```

float A;
String a;
int V;
String v;
float P;
//variable for time
int H;
int M;
int S;
float KW;
String kw = "";
double KWH;
String kwh = "";
double h = 0.0167;
unsigned long previousMillis = 0; //stores the last value
const long interval = 1000; //time interval
String data = "";
String HTTP_cons = "";
String HTTP_fb;
//String processing
String dot = ".";
String underscore = "_";
//Monitoring variables
//initializing pins here
const int PT = A0;
const int CT = A1;
const int relay = A2;
char D [3];
int count;
int switch_r;
int is_request;
//for Keypda
char key;

```

```
String keys_key;
//for storing data
//for feedback
String State;
String Status;
String Units;
//////////////////////////////////FOR GPRS//////////////////////////////////
enum _parseState {
    PS_DETECT_MSG_TYPE,
    PS_IGNOREING_COMMAND_ECHO,
    PS_HTTPACTION_TYPE,
    PS_HTTPACTION_RESULT,
    PS_HTTPACTION_LENGTH,

    PS_HTTPREAD_LENGTH,
    PS_HTTPREAD_CONTENT
};
```

Appendix 4: Sample PHP Codes for Web Application

```
<?php
session_start();
include 'database.php';
if(isset($_POST['loginSubmit'])){
$Asante_Allah = '}*&%`2`~|5ra5f';
date_default_timezone_set("Africa/Nairobi");
$p=$_POST['passd'].$Asante_Allah;
//check if consumer number exists
$bbl=$db_con->prepare("SELECT * FROM member WHERE Consumer_Number=:em");
//execute query
if( $bbl->execute(array(':em' => $_POST['mimi'])))
if ($bbl->rowCount()==1){
//fetch rows
$real = $bbl->fetch();
// if consumer number exists select all including password to be verified below.
$smmtp=$db_con->prepare("SELECT * FROM member WHERE
Consumer_Number=:emm");
if($smmtp->execute(array(':emm'=>$real['Consumer_Number'])))
$userData = $smmtp->fetch();
if($userData){
if (password_verify($p,$userData['password'])){
$value=password_hash($Asante_Allah.$real['Consumer_Number'],PASSWORD_BCRYPT);
if (isset($_POST['keep'])){
$ttp=$db_con->prepare("SELECT * FROM cookie WHERE id=:dd");
$ttp->execute(array(":dd"=>$userData['Consumer_Number']));
if ($ttp->rowCount()==1){
$t=$db_con->prepare("UPDATE cookie SET token=:tkk,sess=:sec,tym=:tm WHERE
id=:dd");
$t->execute(array(":dd"=>$userData['Consumer_Number'],":tkk"=>$value,":sec"=>'userData'
,":tm"=>date('Y-m-d h:i:s')));
$_SESSION['userData'] = $userData;
```

```

setcookie("user_data", $userData['Consumer_Number'], time() + (86400 * 30), "/", ""); //
86400 = 1 day
header("Location:index");
exit();
}else{
$sgmt=$db_con->prepare("INSERT INTO cookie(id,token,sess,tym)VALUES
(:ddy,:tkk,:aka,:tm)");
$sgmt->execute(array(":ddy"=>$userData['Consumer_Number'],":tkk"=>$value,":aka"=>'user
Data',":tm"=>date('Y-m-d h:i:s')));
//userData session variable
//user_data cookie variable
//sessData variable for display message( success or error message)
$_SESSION['userData'] = $userData;
setcookie("user_data", $userData['Consumer_Number'], time() + (86400 * 30), "/", ""); //
86400 = 1 day
header("Location:index");
exit();
}
}
$_SESSION['userData'] = $userData
$_SESSION['user_data'] = $userData["Consumer_Number"];
header("Location:welcome");}
else{
$sessData['status']['type'] = 'error';
$sessData['status']['msg'] = '<b style="color: red">Invalid Password</b>';
$_SESSION['sessData'] = $sessData;
header("Location:index");
}exit();
}else{
$sessData['status']['type'] = 'error';
$sessData['status']['msg'] = "<b style='color: red'>Consumer Number doesn't Exist</b>";
$_SESSION['sessData'] = $sessData;
}exit();

```