

2019-03

Broadband last-mile connectivity model for effective bandwidth utilization in rural and urban-underserved areas

Byanyuma, Mastidia

NM-AIST

<https://doi.org/10.58694/20.500.12479/306>

Provided with love from The Nelson Mandela African Institution of Science and Technology

**BROADBAND LAST-MILE CONNECTIVITY MODEL FOR
EFFECTIVE BANDWIDTH UTILIZATION IN RURAL AND URBAN-
UNDERSERVED AREAS**

Mastidia Byanyuma

**A Dissertation Submitted in Partial Fulfillment of the Requirements for the Degree of
Doctor of Philosophy in Information and Communication Science and Engineering of
the Nelson Mandela African Institution of Science and Technology**

Arusha, Tanzania

March, 2019

ABSTRACT

Broadband last-mile connectivity is a necessary access infrastructure to bridge the digital divide which is more pronounced in rural areas and is also a means to drive the utilization of international bandwidth that is available to a country. Rural areas inhabit more than 70% of the population in Tanzania and are characterized with poor basic infrastructure and services such as roads, schools, hospitals, financial and social services. Engagement of rural communities is crucial for economic development. In the beginning of the 20th century and beyond, the major problem was to find a technology that would successfully connect the rural and remote areas cost effectively. At that time the only feasible technology for these areas were satellite and wired technologies, which required huge investment funding to connect the users; especially those in areas that have sparsely distributed population and far away from urban centres. The main objective of this research is to develop a broadband last-mile connectivity model for efficient bandwidth utilization. The study builds on the telecentre model that have since the beginning of the 20th century been introduced to serve the scattered users in the remote, rural and or underserved areas which seemed unattractive for investment. This research reviews the general status of telecommunication services provision in rural areas using Arusha, Tanzania as a case study and proposes the optimized bandwidth Rural Broadband Service Broker (RBSB) model to solve the problem of low utilization of broadband services in rural and urban-underserved areas. The proposed model not only ensures efficient utilization of resource but is also a way to aggregate users at a common centre where knowledge transfer is achieved. The study has employed qualitative and quantitative research methods for the state of art part of the study and scientific design, modelling simulation to develop the optimized bandwidth RBSB model using MATLAB software. The findings show that with proper optimization solution, it is possible to provide services in low income areas to achieve both quality and affordable price through resource sharing and utilizing the unused chunks of bandwidth using Cognitive Networks Analysis. The proposed model eliminates the high dependence on government and donor funding to reach rural areas and hence promise affordable and sustainable service provision. The recommended model requires among others the entities such as the UCSAF to consider this model as a tool to speed up the universal communication access process and hence provide initial/start-up funding, training, technical advice and Monitoring and Evaluation to those who are willing to venture into this business. This is expected to ensure the universal communication access to broadband services in rural and urban-underserved areas is achieved.

DECLARATION

I, Mastidia Byanyuma do hereby declare to the Senate of the Nelson Mandela African Institution of Science and Technology that this dissertation is my own original work and that it has neither been submitted nor being concurrently submitted for degree award in any other institution.



Mastidia Byanyuma (Candidate)

22.03.2019

Date

The above declaration is confirmed



Dr. Zaipuna O. Yonah (Supervisor)

22.03.2019

Date

COPYRIGHT

This dissertation is copyright material protected under the Berne Convention, the Copyright Act of 1999 and other international and national enactments, in that behalf, on intellectual property. It must not be reproduced by any means, in full or in part, except for short extracts in fair dealings, for researcher private study, critical scholarly review or discourse with an acknowledgement, without a written permission of the Deputy Vice Chancellor for Academic, Research and Innovation, on behalf of both the author and the Nelson Mandela African Institution of Science and Technology.

CERTIFICATION

The undersigned certify that they have read and hereby recommends for examination of dissertation entitled "Broadband Last-mile Connectivity Model for Effective Bandwidth Utilization in Rural and Urban-Underserved Areas" in fulfillment of the requirements for the degree of PhD in Information and Communication Science and Engineering at the Nelson Mandela African Institution of Science and Technology.



Dr. Zaipuna O. Yonah
(Supervisor)

Date 22.03.2019.....



Dr. Fatuma Simba
(Supervisor)

Date 22.03.2019.....



Prof. Lena Trojer
(Supervisor)

Date 22.03.2019.....

ACKNOWLEDGEMENTS

First and foremost I would like to express my loving gratitude to the Living God, Almighty who gave me the strength and favors to complete this research work and accomplish this piece of dissertation document.

Secondly, this dissertation has been achieved through the guidance, love and support of various people. Although I faced a health problem in the middle of my study journey, The Lord's mercies helped me and strengthened me out of illness and through the loving hands of my spiritual parents Ms. Germana Mwacha, Mr. and Mrs. Robert Mitti who were very concerned with my health, social and academic progress until this time. This has made me a better and stronger person.

I am deeply indebted to my internal supervisor, Dr. Zaipuna O. Yonah, for his invaluable knowledge and generous guidance which he provided throughout my research journey and during writing this dissertation. I further owe a warm debt of gratitude to my other two supervisors, Dr. Fatuma Simba and Prof. Lena Trojer for their time and support during my research and preparation of this dissertation, especially their patience with me and moral support when things couldn't move.

My sincere gratitude goes to the staff members of NM-AIST, especially the dean of the school of COCSE and the entire NM-AIST community for their continued support.

I acknowledge with thanks the scholarship accorded to me by the Government through The Commission for Science and Technology (COSTECH) with which this work has been possible. I also extend my gratitude to my employer, The Institute of Finance Management (IFM), for their financial support when the government funding expired and for giving me extended study leave to get more time to accomplish my studies in particular Prof. Tadeo Satta the Rector and Dr. Abeid Gaspar who took his precious time to encourage and give me the support I needed.

My heartfelt gratitude goes to my Faculty Dean and friend, Dr. Faraja Igira who in addition to moral support, she went an extra mile to read my draft dissertation and guide me accordingly to make sure I progressed. This came when I was almost giving up. Together with her are my friends Dr. Doreen Laurent, Dr. Pendo Kiviyiro (my office mate), Dr. Purificator A. Kiwango, Dr. Angel Nyabasi and Dr. Angela-Aida K. Runyoro who encouraged and prayed with me for the breakthrough in my health and studies. I specifically acknowledge the special assistance from Dr. Runyoro and for encouragement to apply for this study, without her I would not have started this journey at that particular time.

I would also like to express my love and appreciation to my family: mother-Susana, brothers -Felix, Richard, Juventus, Laurent, Sadot and Archard; Sisters - Alphonsina, Severina, Erica,

Marisiana and dada Mastidia Kahatano for their love, prayers, encouragement, moral and social support which have made me overcome all obstacles and reach this level.

Last but not least, my husband Godwin and our children, Clarence, Clara, Clauden, Mercy and Anicetha for having to bear my prolonged absence and frequent separation during my study journey. Together with these are my special friends; Frida H. Mpenda, Asteria Mwamengo who took care of my children during the time I was absent. Last but not least, our relatives - Alikiana, Sweetbert and Justha who have stayed with and helped my family at different occasions during my study journey.

DEDICATION

To my Lord, Jesus Christ

&

To my family

TABLE OF CONTENTS

ABSTRACT	i
DECLARATION	ii
COPYRIGHT	iii
CERTIFICATION	iv
DEDICATION.....	vii
TABLE OF CONTENTS	viii
LIST OF FIGURES	xii
LIST OF APPENDICES	xiv
LIST OF ABBREVIATIONS.....	xv
CHAPTER ONE.....	1
GENERAL INTRODUCTION.....	1
1.1. Research Background	1
1.2. Bandwidth Utilization.....	3
1.3. Global Case Studies	4
1.4. Statement of the Problem.....	5
1.5. Significance of the Research	6
1.6. Scope of the Research.....	6
1.7. Research Objectives.....	6
1.8.1. Main Objective	6
1.8.2. Specific Objectives	6
1.8. Research Justification	7
1.9. Dissertation Structure	7
CHAPTER TWO	8
OVERVIEW OF BROADBAND CONNECTIVITY FOR RURAL.....	8
AREAS-TANZANIA AS A CASE STUDY.....	8
Summary	8
2.1. Introduction	8
2.2. Why Broadband?.....	9
2.3. Overview of Broadband Technologies	12
2.4. Broadband Connectivity Model Trend for Rural Areas	14
2.4.1. Mesh Networks	15
2.4.2. Broadband Island	15

2.4.3. Nokia Siemens Village Network	16
2.4.4. Rural Netco Shared Broadband Model	17
2.4.5. Television White Spaces (TVWS).....	18
2.5. Initiatives to Achieve Broadband Connectivity	19
2.5.1. Telecentres.....	20
2.5.2. The Tanzania National ICT Broadband Backbone (NICTBB)	21
2.5.3. The Universal Communication Services Access Fund (UCSAF)	22
2.6. Infrastructure Readiness.....	24
2.7. Policy Readiness.....	25
2.6. Conclusion	26
CHAPTER THREE.....	27
UTILIZATION OF BROADBAND CONNECTIVITY IN RURAL AND URBAN- UNDERSERVED AREAS: THE CASE OF SELECTED AREAS IN ARUSHA-TANZANIA	27
Summary	27
3.1. Introduction	27
3.2. Literature Review	29
3.2.1. What is Utilization	29
3.2.2. Lack of Awareness or Low Literacy Rate.....	30
3.2.3. Network Reliability, Coverage and Affordability	31
3.2.4. Affordability of devices and Air charges	32
3.3. Broadband Connectivity	33
3.4. Methodology	35
3.4.1. Study Area	35
3.4.2. Data Collection	35
3.4.3. Calculation of Utilization	35
3.5. Results and Discussion	36
3.5.1. Connectivity.....	36
3.5.2. Telecentre	36
3.5.3. Rural and Urban-Underserved Users	37
3.6. Conclusion	41
CHAPTER FOUR.....	43
AFFORDABLE BROADBAND CONNECTIVITY MODEL FOR RURAL AREAS	43
Summary	43

4.1. Introduction	43
4.2. Literature Review	45
4.2.1. Viability and Sustainability	45
4.2.2. Shared Services Models	46
4.2.3. Choice of Technology	46
4.3. Model Definition and General Assumptions.....	51
4.3.1. Model Definition.....	51
4.3.2. Model Assumptions	54
4.4. Conclusion	54
CHAPTER FIVE	56
A MODEL FOR OPTIMIZATION OF BANDWIDTH UTILIZATION IN RURAL AND URBAN-UNDERSERVED AREAS USING QUEUING ANALYSIS	56
Summary	56
5.1. Introduction	56
5.2. Related Work.....	59
5.3. The Rural Broadband Service Broker (RBSB) Model	61
5.3.1. The RBSB Conceptual Bandwidth Model	61
5.3.2. The M/D/1 Model	62
5.3.3. Priority Queuing Model.....	63
5.3.4. PU Average Packet Delay	65
5.3.5. SU Average Packet Delay	65
5.3.6. Optimal Number of SU Packets.....	67
5.4. MATLAB Simulation Results and Discussion	69
5.4.1. The Effect of Increasing the PU Packets Arrival on Optimal SU Packets Arrival	69
5.4.2. The Effect of Increasing Reward A on Optimal SU Arrivals.....	69
5.4.3. Effect of Operational Cost B on Optimal SU Packets Arrival	70
5.4.4. Effect of Service Rate μ on Optimal SU Arrival	72
5.5. Conclusion	73
CHAPTER SIX.....	75
GENERAL DISCUSSION, CONCLUSION AND RECOMMENDATIONS.....	75
Summary	75
6.1. General Discussion	75
6.2. Research Contributions.....	78

6.3. Concluding Remarks	78
6.4. Recommendations	79
6.4.1. Policy Advice to the Government	79
6.4.2. Operational Advice to Network Operators (NOs)	80
6.5. Future Work	80
REFERENCE	81
APPENDICES	92

LIST OF FIGURES

Figure 1: Percentage of Rural Population in the Low Income and Middle Income Countries .	2
Figure 2: Global ICT Indicators	11
Figure 3: Internet Users by Technology Type and Penetration in Tanzania as per TCRA2018 statistics	11
Figure 4: PON and WiMAX Integration (Simba <i>et al.</i> , 2011).....	14
Figure 5: Optical Fibre with WiMAX (Simba <i>et al.</i> , 2011).....	14
Figure 6: Nokia Siemens Village Network.....	16
Figure 7: Rural Netco Shared Broadband Model.....	17
Figure 8: TVWS network Architecture.	19
Figure 9: Sengerema, Mwanza Telecentre.....	20
Figure 10: Geographical and population uncovered percentages for selected wards.....	23
Figure 11: Halotel Coverage Map as at the end of 2016.	31
Figure 12: Vodacom Coverage Map in 2018.	32
Figure 13: World Internet Penetration in 2012.	34
Figure 15: Bandwidth Capacity Utilization of the Longido Radio Link.	40
Figure 16: Bandwidth Capacity Utilization of Karatu Radio.....	40
Figure 17: Bandwidth Capacity Utilization of Ngurudoto Radio Link.	40
Figure 18: Bandwidth Capacity Utilization of NM-AIST Fibre Link.....	41
Figure 19: Bandwidth Capacity Utilization of Arusha University Link.....	41
Figure 20: MMDS Architecture.	49
Figure 21: Conceptual Framework for Broadband Shared Services Broker Model for rural areas.	52
Figure 22: The Conceptual Rural Broadband Service Model showing the Subscribed Bandwidth and the Shared Bandwidth to PU and SUs respectively.	62
Figure 23: A cognitive wireless network diagram showing PU and SUs (Suliman and Lehtomaki, 2009).....	63
Figure 24: The effect of increasing PU packets arrival on optimal SU packets arrival	69
Figure 25: The effect of increasing a reward α on optimal SU packets arrival in packet/sec.	70
Figure 26: The effect of increasing the operational cost β on optimal SU packets arrival in packets/sec.....	71
Figure 27: The effect of increasing the service rate (μ) on optimal SU packets arrival λ_s^* ..	73

LIST OF TABLES

Table 1: Link and Installed Capacity for Rural Users in Arusha, Tanzania.	38
Table 2: Comparisons between Broadband Technologies.	50
Table 3: Priority and Service Differentiation for the Rural Broadband Service Broker.	53

LIST OF APPENDICES

Appendix 1: Detailed Analysis for the Optimum Number of Secondary User (SU) Packets Arrival by Applying Differentiation by Parts the Equation	92
Appendix 2: A Questionnaire for Internet Service Providers (ISP) in Arusha	94
Appendix 3: The Map of the Study Area: Districts and Organisation Neighboring the Nelson Mandela African Institution of Science and Technology (NM-AIST)	97

LIST OF ABBREVIATIONS

2G	Second Generation Telecommunication Networks
3G	Third Generation Telecommunication Networks
4G	Forth Generation Telecommunication Networks
ADSL	Advanced Digital Subscriber line
AP	Access Point
BPL	Broadband over Powerline
BS	Base Station
CAPEX	Capital Expenditure
Cat6	Category 6
Cat5	Category 5
COSTECH	Commission for Science and Technology
CPE	Customer Premise Equipment
EDGE	Enhanced Data rates for GSM Evolution
EPOCA	Electronic and Postal Communication Act
FiWi	Fibre Wireless
FTP	File Transfer Protocol
FTTH	Fibre to the Home
GDP	Gross Domestic Product
GPRS	GSM Packet Radio Service
GSM	Global System for Mobile communication
HSPA	High Speed Packet Access
ICT	Information and Communication Technology
IDC	Internet Data Centre
IEEE	International Electrical and Electronics Engineering
IP	Internet Protocol
ISDN	Integrated Services Digital Network
ISP	Internet Service Providers
ITU	International Telecommunication Union
LMDS	Local Multipoint Distribution Service
LTE	Long Term Evolution
MANET	Mobile Ad Hoc Network
Mbps	Megabits per second

MIMO	Multiple-Input and Multiple-Output
MoWTC	Ministry of Works, Transport and Communication ()
MMDS	Multichannel Multipoint Distribution Service
MNO	Mobile Network Operators
NBS	National Bureau of Statistics
NICTBB	National Information and Communication Technologies Broadband Backbone
NICTP	National ICT Policy
NO	Network Operator
NSN	Nokia Siemens Network
NSVN	Nokia Siemens Village Connection
OFC	Optical Fibre Network
OPEX	Operational Expenditure
OPGW	Optical Power Ground Wire
PON	Passive Optical Network
PPP	Private-Public Projects
PPPP	Public Private People's Partnership
PU	Primary User
QoS	Quality of Service
RBSB	Rural Broadband Service Broker
RSA	Republic of South Africa
SU	Secondary User
TANESCO	Tanzania Electric Supply Company Limited
TCRA	Tanzania Communication Regulatory Authority
TDV	Tanzania Development Vision
TTCL	Tanzania Telecommunication Company Limited
TTN	Tanzania Telecentre Network
TVWS	Television White Spaces
UCSAF	Universal Communication Services Access Fund
UMTS	Universal Mobile Telecommunications System
URT	United Republic of Tanzania
USAF	Universal Service Fund
VPN	Virtual Private Network
VSAT	Very Small Aperture Terminal
Wi-Fi	Wireless Fidelity

WiMAX	Worldwide Interoperability for Microwave Access
WMN	Wireless Mesh Network
WSIS	World Summit on Information Society

CHAPTER ONE

GENERAL INTRODUCTION

This Chapter presents the general background to the research problem, the objective of the study, the statement of the problem and significance of the same. It also presents the organization of the research report and gives a summary of the content of the dissertation.

1.1. Research Background

Broadband last-mile connectivity is a critical element in ensuring that Information and Communication Technology (ICT) innovation is enabled around the world (Johnson, 2014). Despite its importance, there is a widely acknowledged urban-rural digital divide (Philip *et al.*, 2017) implying that this critical service is not equally available in different areas on the globe. Broadband access to the Internet, in particular, is becoming a necessity for obtaining information and resources about socio-economic activities like; healthcare, education, and employment. However, the broadband global digital divide continues to inhibit and limit individuals' access to the internet within and among nations (Philip *et al.*, 2017).

Although rural areas in developed, developing and least developed countries may exhibit different characteristics in terms of the level of education, income and culture, they have one thing in common; and that is: low level of service provision and are the most unattractive areas for businesses. It is for this reason governments, national and international organizations such as the International Telecommunication Union (ITU) and World Bank are working on supporting and/or subsidizing provision of ICT services in these areas.

In most of the low and middle income countries such as Tanzania, more than 50% of the population resides in rural areas as compared to the United States with only less than 20% residing in rural areas. Tanzania, in particular, has about 68% of the population residing in rural areas as per World Bank estimations based on Tanzania 2012 Census (World Bank, 2017). Most of these areas are isolated from urban centres and are characterized by poor or inadequate basic infrastructures (roads, schools, hospitals, power supply, and financial services). Although the trend of rural percentage population is decreasing in all countries as shown in Fig. 1, this is not something to count on because rural areas need to be engaged in the economy, need to be developed, need to have universal access to information and other services.

Urbanization is another problem in itself, because movement of people to urban centres result in overpopulating the urban centres which brings other challenges. Furthermore, rural areas most of which are agrarian remain with less manpower to work on agricultural and other activities in those areas, which continue to reduce the number of people working in economic activities. Most of these rural-urban migrants end up facing unemployment in towns and other hardships (Magnér, 2008). Even where the rural population is smaller than urban population, still they need to be connected to allow for universal access to ICTs like in countries such as United States who refer to “connecting the final few” probably because most of them are already connected or because the percentage as seen in Fig. 1 is only 18% for 2015 data. This is unlike the case of Tanzania and other countries of similar economic status that are struggling to connect the majority who are in rural areas.

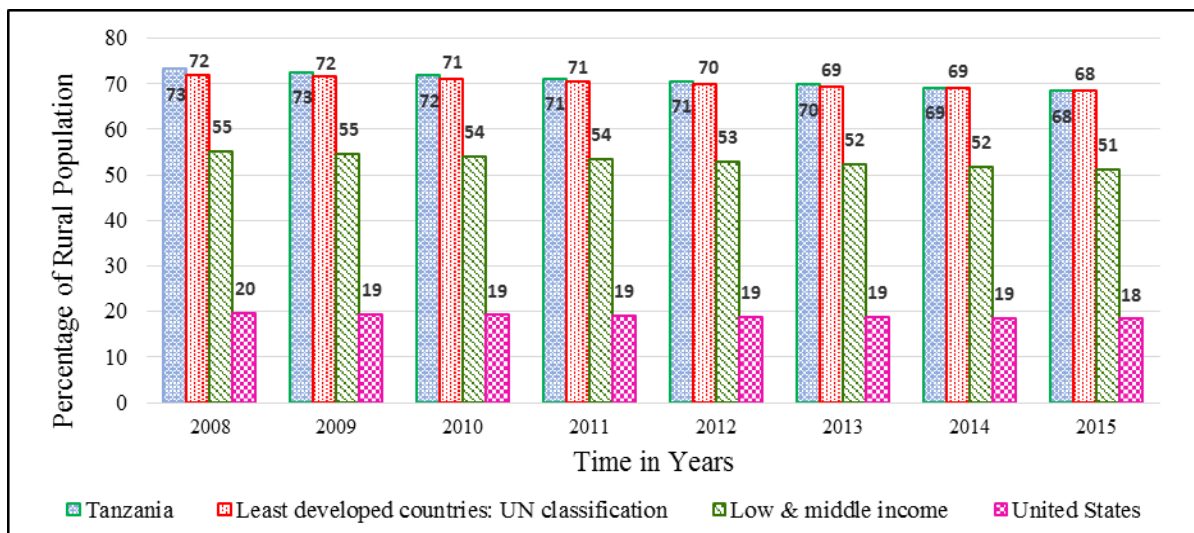

Figure 1: Percentage of Rural Population in the Low Income and Middle Income Countries

Availability of ICT services in the rural community avail a lot of benefits. Some of these are:

- i) Provision of specialized knowledge to rural users in farming areas,
- ii) More possibilities to advertise and sell their products in the national and international markets,
- iii) Reduction of traveling needs and costs,
- iv) Improvement of their methods and techniques in agriculture and small industries,
- v) Reduction of input costs and improvement of production efficiency and increase of price competition.

Broadband access, in particular, improves the productivity of businesses, supports the creation of new products and services and accelerates innovation (Stork *et al.*, 2013). With

broadband last-mile connectivity, all sectors have equal chances to benefit from application of ICT based services like e-commerce, e-industry, e-management, e-government, e-medicine, e-health and e-learning to eradicate poverty and bridge the digital divide.

Tanzania through its Ministry of Works, Transport and Communication (MoWTC) envisions to have a knowledge based Tanzanian society with the capacity and capability to harness Science, Technology and Innovation for the transformation of the economy that is sustainable and globally competitive (URT, 2016). For a country like Tanzania, talking of the national economy it is not realistic to consider only urban areas which is only 32% (World Bank, 2017) of the population.

However, bringing broadband connectivity and associated services to the community is one issue, but making use and hence utilizing the available services is yet another issue. That is, some areas have broadband connectivity but due to some reasons as will be discussed in this dissertation, they are not able to use the connectivity services. In this regard, various issues have motivated this research work and these are:

- i) Availability of the state of the art high capacity broadband backhaul network (NICTBB) plus the national agenda to provide services to all at a reduced cost
- ii) Availability of MNOs/UCSAF subsidization of services in unattractive areas for investment hence it is more important to make sure the benefits of this are accrued to the society
- iii) NM-AIST motto of “academia for society and industry” that value studies addressing the society and industry.
- iv) All the above motivations were driven from the Tanzania ICTs policy 2003 and 2016 respectively.

These motivations are still valid and this study is just a small part of ongoing research in the area to ensure the rural urban gap is minimized or eliminated.

1.2. Bandwidth Utilization

Utilization of Bandwidth in this context refers to the fact that some areas have connectivity within their vicinity but they cannot use it; a case of rural areas in Arusha which has fibre and microwave broadband connectivity in their close proximity but these are serving those few anchor customers (hotels, banks, private schools and some international organisations) (Byanyuma *et al.*, 2016). In this particular study, the issue was not why some anchor

customers had connectivity while the communities had absolutely none, but the issue was a possibility of using such connectivity to connect the neighborhood especially if the available bandwidth was satisfactory. The real issue becomes more evident when you consider that neighboring schools have no enough teachers, no books and laboratories, a lack that could be eliminated by the nearby connectivity. A good example is the e-reader project (Machuve *et al.*, 2014) that was meant to solve the problem of lack of books in Nganana and Nambala Primary schools in Meru District, Arusha. Sharing resources already paid for, is not a new phenomenon in itself, it is similar to the case of network infrastructure sharing by telecommunication network operators adopted and regulated by telecommunication regulators such as Tanzania Communications Regulatory Authority (TCRA) (TCRA, 2011) except that, in this case, the involved parties are not operators but individuals and public facilities that can be ready to share the link with the neighborhood.

Another form of bandwidth utilization problem is seen from the recent availability of the mobile coverage in Tanzania that has been collectively achieved by the mobile operators and the Universal Communication Services Access Fund (UCSAF) subsidy. This coverage is overwhelming to have reached 95%¹. Now the question is whether or not this coverage is readily taken up for connectivity countrywide and whether the coverage contains the right technology for broadband services.

1.3. Global Case Studies

Broadband access gap has been reported worldwide by various researchers. Although the extent of this gap varies between countries, most of the reported cases are those in rural and urban-underserved areas and mostly in Africa and other emerging markets. The gap is seen to be wide in African countries despite efforts made by governments to revamp the telecommunications sector e.g. the establishment of submarine cables (Moturi and Nyota, 2012). Furthermore, LaRose *et al.* (2007) reports persistent urban-rural broadband gap despite narrowed geographic disparities in high speed Internet access.

Gospic *et al.* (2010) argue that broadband access have actually allowed developing countries to “leap-frog” past inadequate infrastructure. However, economic factors have caused the

¹This is indicated on the Mobile Telecommunication Company website (Viettel Tanzania Limited known as Halotel), that it has laid about 18 000 km fibre plus 2500 antenna towers all over the country making about 90% coverage all over Tanzania. Available at <http://halotel.co.tz/>

distribution of a new ICT infrastructure to be uneven. In rural areas, development is very slow, and a new digital/broadband gap is increasing. The situation is similar to that in the developed world where in early 2009 it was estimated that 30 percent of the rural European population still had no broadband access. This gap has been effectively addressed in developed countries and that the most important aspect is not the connectivity but rather effective utilization of the deployed broadband connectivity to deliver acceptable user experience for it to be beneficial to communities and bridge the digital divide (Park *et al.*, 2013). In their paper, Park *et al.* (2013) try to pin point the utilization and sustainability of broadband adoption in rural areas in South Korea where they found that investment in human capital is more important than investing in infrastructure and that involvement of local communities in the connectivity initiatives made an impact. This is the case with many other countries like Tanzania, where there is a good number of initiatives to connect the rural areas but the impact is not seen. One of the reasons for low impact is the fact that the intended users are always not involved in planning and implementation of those initiatives.

In a mission to address the problem of lack of affordable internet connectivity in emerging countries, which is seen as a major barrier for access to knowledge, education and government services, Rademacher *et al.* (2013) designed a cost effective low power IEEE802.11n (MIMO) hardware together with a single polarized antenna. Their solution promises a high bandwidth backhauling at minimal power consumption and low latency. In this they achieved a throughput of up to 200 Mbps at over 10 km of a typical forwarding node well below 10 Watts. Although combination of a low cost backhaul network and the last-mile access network would lower the overall cost of connectivity, the overall reduction in cost may take time to reach a normal user unless some models specifically for rural and underserved areas would consider these network combinations and model them to solve this particular problem.

1.4. Statement of the Problem

While mobile phones have spread quickly even in low-income countries and among poorer population groups, access is by no means universal and internet access remains very low in many countries (Deichmann *et al.*, 2016). The question that comes here is how many people own mobile phones, how many use mobile phones to access the internet, how many of those connected experience the same speed and quality and how many can even afford to own a mobile phone to make use of the available coverage. Therefore, the issue can be generally

seen from the availability, usability/accessibility, affordability, and reliability of the service, which sums up to a lowered utilization of the available capacity at their disposal. As a result, few people are able to afford and use reliable services in terms of internet access and other services. This is an inefficient use of bandwidth resource that is at their disposal. In this regard, the problem addressed by the study reported in this dissertation is that of effective bandwidth utilization in Tanzania rural and urban-underserved areas.

1.5. Significance of the Research

The main significance of this research is its contribution to governments' efforts to bring services to rural areas and specifically to drive utilization of broadband connectivity for development through the achievement of universal access and elimination of the rural-urban digital divide.

1.6. Scope of the Research

This research discusses broadband last-mile connectivity models for rural and urban-underserved areas and examines the utilization of broadband resources available in those areas. It also explores the available initiatives, models and best technologies that provide affordable services to be offered to the communities. Finally, the model for sustainable and affordable ICTs access is recommended. However, it is beyond the scope of this research to implement and test the system to achieve the recommended model.

1.7. Research Objectives

In order to address the problem of broadband last-mile connectivity in rural and urban-underserved areas, this research had one main research objective and two specific research objectives.

1.8.1. Main Objective

The main objective of this research is to develop a broadband last-mile connectivity model for effective bandwidth utilization in rural areas, using Tanzania as a case study.

1.8.2. Specific Objectives

The specific objectives of this research are:

- i) To identify connectivity options and bandwidth utilization for various user experiences in rural areas
- ii) To design and simulate the broadband last-mile connectivity model for delivering acceptable user experience in rural areas.

1.8. Research Justification

Studies to address the digital divide, broadband access gap and data divide in the rural and underserved areas have been addressing mainly the lack of cost effective broadband last-mile infrastructure (Le-Ngoc and Le, 2009) and hence proposing the implementation of the same. While the problem of affordable broadband last-mile connectivity has been substantially addressed, there is still much concern on the utilization of the available or unused resources in terms of bandwidth (Nika *et al.*, 2012), frequency spectrum (Maleki *et al.*, 2015; Oh *et al.*, 2016), installed capacity and communication access devices such as mobile phones.

1.9. Dissertation Structure

This dissertation is organized as follows:

Chapter 1 presents the introduction and background to the problem, the problem statement, research objectives, significance of the research and scope. Chapter 2 presents the status of broadband connectivity in rural areas. Chapter 3 presents the research gap which is the Utilization of Broadband Connectivity in Selected Areas in Arusha-Tanzania. Chapter 4 presents the proposed model to drive bandwidth utilization in rural areas using the shared service model. Chapter 5 presents the analytical modeling and MATLAB simulation of the developed model. Chapter 6 presents the research conclusion, recommendations and research contributions.

CHAPTER TWO

OVERVIEW OF BROADBAND CONNECTIVITY FOR RURAL AREAS - TANZANIA AS A CASE STUDY²

Summary

Broadband connectivity is a necessary service required not only in urban areas but more so in rural areas where most of the basic services are inadequate or do not exist at all. Broadband services can enable many services to be offered through information and communication technologies (ICTs) to the extent that rural people can get a chance to enjoy quality communication and other services as in urban areas and be part of the socio-economic development of a given community. Currently, there is a number of technologies and initiatives to connect rural and urban-underserved areas at a reasonable cost but most of the rural users are yet to be connected. This Chapter gives an overview and a discussion on technologies, broadband connectivity models, infrastructure and policy readiness and initiatives towards achieving connectivity and bridging the digital divide. The context of this study is rural areas in Tanzania.

2.1. Introduction

In recent years, broadband connectivity has been a necessity for provision of real-time applications to subsidize the lack of basic services in most areas of developing countries. However, last-mile broadband connectivity to rural areas (i.e. extending the available infrastructure to reach rural users) has been taking a slow speed. Despite its importance to national economies and the personal lives of users, its availability and adoption are not diffusing in rural and urban areas at the same rates (Prieger, 2013). The main reason to this remains the lack of purchasing power to attract investments. This is evident from various governments' initiatives to subsidize the same through Universal Communications Services Access Funds like UCSAF in Tanzania, Universal Service Fund (USF) in Kenya and Universal Service and Access Fund (USAF) in South Africa.

²This chapter is based on the paper:

1. Byanyuma, M., Yonah, Z. O., Simba, F. and Trojer, L. (2016, June), Overview of Broadband Connectivity for Rural Areas, Tanzania as a Case Study that was presented at the *2nd International ICT Summit, Current and Emerging Technologies for Social-economic Development, Dar es Salaam Tanzania* that has also been published in *The International Journal of Computer Science and Information Security, (IJCSIS)*

Most of these rural areas are without or have poor basic facilities such as hospitals, schools, road and other social services (Joyce-Gibbons *et al.*, 2017). In Tanzania for example, there are many schools in rural areas with very few teachers, with no laboratories, books and other learning tools (Byanyuma *et al.*, 2013; Machuve *et al.*, 2014). These areas are also the ones inhabited by more than 70% (NBS, 2016) of the population despite the lack of basic needs. Reasons behind the poor or inadequate provision of services in rural areas include among others; perceived business risk attributed to unpredictable revenue streams, high investment cost attributed to infrastructural and cost demands of the current technologies, unstable policies in some countries and weak business models (Naik, 2011). These and other problems have slowed down development in these areas because, traditionally, investors perceive rural and urban-underserved areas as low revenue, high costs, and high-risk areas.

As a case study, the Tanzania government has embarked on connecting the last-mile in rural and urban-underserved areas through various initiatives. The last phase (5th Phase) of the National Information and Communication Technologies Broadband Backbone (NICTBB) project is to extend the broadband connectivity to the last-mile in rural and urban-underserved areas. The Mobile Operators through the UCSAF subsidization initiative and Halotel have collectively covered more than 90% of the geographical area of the country in which case every ward has at least a 2G cellular network coverage.

However, according to the National ICT policy of 2016 (NICTP2016), most citizens still cannot access broadband services (URT, 2016). Despite the stated inadequacy of broadband services to rural areas, the engagement of rural communities is crucial for economic development and social transformation through e-governance (Chaudhari, 2011) and other programs. Broadband service, in particular, is an important contributor to increased country's Gross Domestic Product (GDP), job creation, broadening of education opportunities, public service delivery, and rural development if the reach, availability, and affordability are guaranteed and the demand and supply side skills to exploit the economic and innovative potential of broadband are developed (RSA, 2013).

2.2. Why Broadband?

Broadband is the transmission capacity that is faster than the primary rate Integrated Services Digital Network (ISDN) of at least 2.0 Megabits per second (Mbps). With this capacity, end users can browse the internet, transfer information (multimedia) more freely and possibly on

real time speed. In areas with challenging transport and other socio-economic infrastructure, telecommunications infrastructure in terms of both voice, data and video, plays a greater role in balancing the socio-economic activities of a given area. The broadband technology in particular, is termed as general purpose technology because adoption of the same results in improved lives in a given area as seen from minimized depopulation caused by poor living conditions in rural areas in the Bavaria State in German and indicating that an improved broadband coverage makes these municipalities more valuable places to live (Briglauer *et al.*, 2016). Taking an example of mobile money innovation in East Africa (Economides, 2015), through telecoms infrastructure, financial services are everywhere regardless of the geographical situation of an area as long as mobile coverage is there. This is why a mobile phone is termed as a vehicle that could be utilized efficiently to generate profits (Donner, 2008) and reduce costs in business enterprises (Komunte, 2015) a fact any entrepreneur will capitalize on.

Also, broadband connectivity has made it possible for social networking applications such as WhatsApp, twitter, and Facebook which continue to bring people closer in space such that distance is no longer an issue. Some users have benefited from sharing useful information on farming, health, educational and news on what is happening worldwide. Others have used them to promote their businesses, products, and services at a cost of mobile data top-up. All these have been possible through broadband media, in particular, mobile broadband through the cellular network which has comparatively a wider coverage in rural areas.

The status of cellular network coverage is increasing yearly along with improvement in value-added services and applications (mobile apps) which comes with associated benefits to users. In Fig. 2, the mobile cellular penetration rate worldwide is 101% (7.7 billion mobile cellular subscriptions), which has increased from 5.3 billion subscriptions in 2010 whereas the mobile broadband technology had a penetration of about 56% in 2017 that increased from 28.5% in 2010. The global internet penetration in terms of individual using the internet was 28% in 2010 which has increased to 47% in 2017 (Broadband Commission for Sustainable Development, 2017).

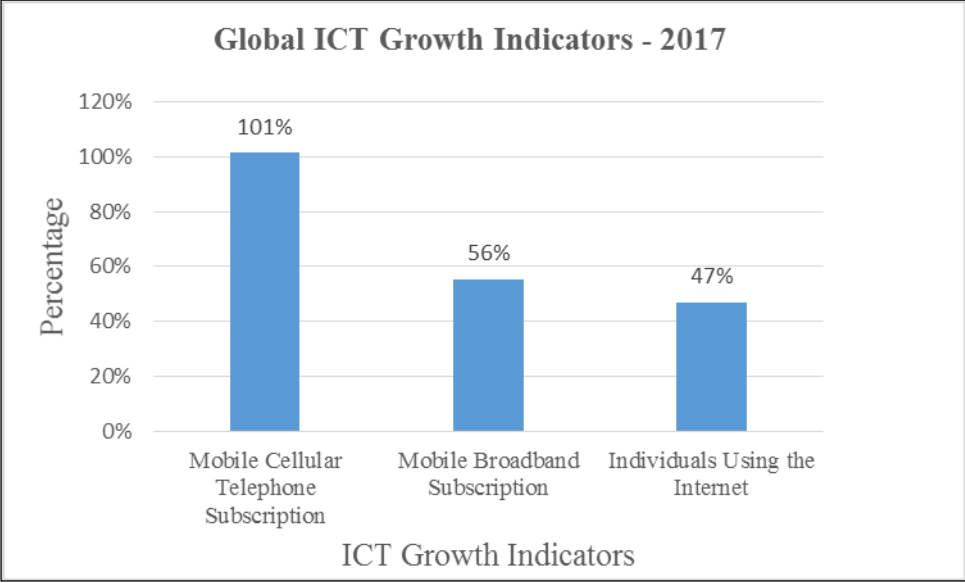

Figure 2: Global ICT Indicators

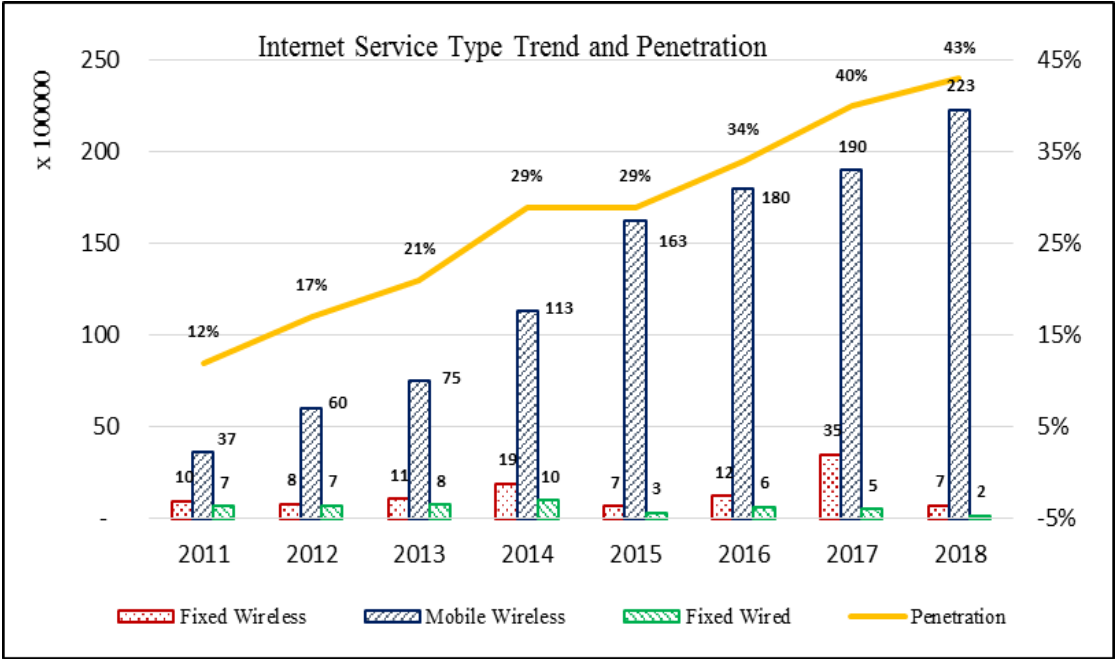

Figure 3: Internet Users by Technology Type and Penetration in Tanzania as per TCRA 2018 statistics

Specifically, Fig. 3 shows the trend of internet use in Tanzania where the mobile wireless has shown a growing adoption from 2011 to 2018. The internet penetration including both wired and wireless (fixed and mobile) were 43% in 2018 which had increased from 12% in 2011 also indicating a tremendous growth in a very short time. The combination of growth in

mobile broadband penetration and the emerging cost-effective technologies is likely to impact communities since this is the only technology that can reach most of the areas easily, a fact that promises more investment in the sector hence increased associated benefits to the society.

Users regardless of their geographical area need affordable and reliable broadband access which is vital for the provision of enhanced ICT applications (ITU, 2017a) such as telemedicine, e-learning and other innovations that may come up in a course of science and technology advancement to improve livelihood.

In this study, we find that broadband connectivity is currently not an issue to worry about but the issue is adoption, availability, usage and user experience of broadband services.

2.3. Overview of Broadband Technologies

There are many different types of broadband technologies, which may be wired or wireless technologies. On one hand, most of the wired technologies such as dial-up, Advanced Digital Subscriber line (ADSL), Cable, leased line (T1), Broadband over Powerline (BPL) and fibre optic cable have for a long time been expensive means to reach rural areas where in most cases the population density is very low. On the other hand, wireless technologies such as fixed wireless, Wi-Fi, Satellite, Television White Space (TVWS) (Masonta *et al.*, 2013, 2015a; Patil *et al.*, 2013), GPRS/EDGE, Worldwide Interoperability for Microwave Access (WiMAX) (Ahmadi, 2009; Mandioma *et al.*, 2006; Rakesh and Dalal, 2010) and Long Term Evolution (LTE) are available and can be used to connect the rural users. Other fixed wireless technologies are such as the Local Multipoint Distribution Service (LMDS) and Multichannel Multipoint Distribution Service (MMDS) (Armanious, 2001; Soma *et al.*, 2002).

Among all these technologies, only a few can be used cost effectively to provide rural and urban-underserved areas with broadband connectivity due to various reasons. For instance, the wired technologies need comparatively higher investment cost to reach rural areas making them non-feasible for rural last-mile connectivity. The wireless technology in rural and urban-underserved areas of Tanzania are dominated by GPRS, EDGE and VSAT network services which offer limited throughput unsuitable for real-time applications. Universal Mobile Telecommunications System (UMTS), High Speed Packet Access (HSPA) and LTE which are designed to offer broadband services, are deployed in urban areas where population density justifies investment leaving rural areas uncovered by these high capacity technologies

The possible reasons for deployment of the UMTS, HSPA, and LTE only in city centers are coverage limitation that would require significant investment costs to cover all rural areas.

However, some of these technologies can be used as first or middle-mile in combination with other wireless technologies. Various initiatives have proposed or implemented a combination of the above technologies to achieve reach, capacity, and quality of service. In some of these, both wired and wireless technologies have been recommended to be used together to achieve the required throughput and convenience. Example, in some areas fibre optic technology has been proposed to be combined with MMDS as the access network to reach rural and urban-underserved areas (Byanyuma *et al.*, 2013). Alternatively, UMTS operating at 900 MHz is used to extend the capacity and coverage of UMTS at 2100 MHz to rural areas where the available technology is GSM/EDGE with low data rate (Simba *et al.*, 2011).

Various technologies are available to date to achieve broadband connectivity and these are either implemented in different areas or are proposed to be implemented. Most of these are a combination of one or two technologies with the aim of lowering capital expenditure (CAPEX) and operational expenditure (OPEX) while achieving the desired goal in terms of quality of service, reach, sustainability and affordability. In this section, both used and proposed technology set-ups for broadband connectivity for rural areas are presented.

A combination of different technologies has been recommended to be a good option to reach rural areas cost effectively with required throughput. This is because some of the technologies despite their high capacity and QoS are not viable to use to extend the same as the access network. For instance, combining Optic Fibre technology with WiMAX (FiWi) is one of the hybrid technology where WiMAX is used to extend the reach of Fibre Optic connectivity to the users (Simba *et al.*, 2011). Such set up are Passive Optical Network (PON) with WiMAX integration and Optical Fibre with WiMAX integration as shown in Figs. 4 and 5, respectively (Simba *et al.*, 2011).

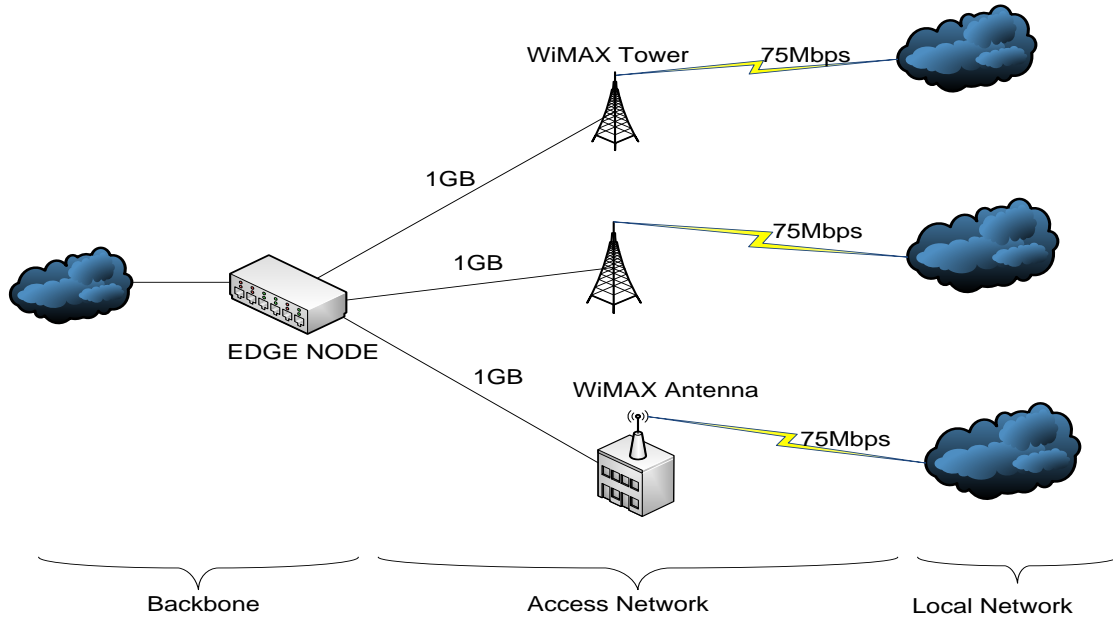

Figure 4: PON and WiMAX Integration (Simba *et al.*, 2011).

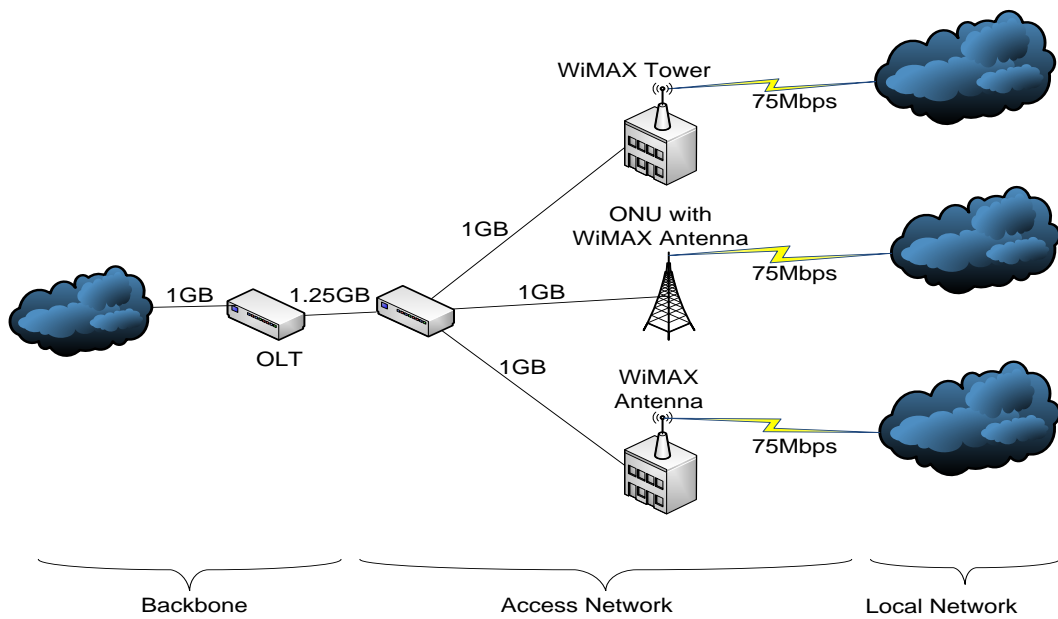

Figure 5: Optical Fibre with WiMAX (Simba *et al.*, 2011).

2.4. Broadband Connectivity Model Trend for Rural Areas

Various models are proposed by various researchers for Tanzania environment taking into consideration: technology, network set up, management and other factors to achieve the

desired service. Examples of rural and urban-underserved areas models are Mesh networks, Broadband Island, Nokia Siemens Networks and Rural Netco shared broadband model.

These are presented in the next paragraphs. These models aim at connecting the rural areas in its totality. While these models are prospective general technologies especially proposed for the rural area, currently we have a cellular coverage of about 90% as stated previously and fibre optic network coverage of almost 25 600 km. Out of this, 7600 km is a core network built by the government of Tanzania while 18 000 km of fibre is mostly an access network built by Halotel.

2.4.1. Mesh Networks

A WiMAX mesh network that lowers the subscriber's cost and helps to bridge the digital divide through the elimination of the middleman (i.e. ISPs) is proposed in (Sedoyeka and Hunaiti, 2011). WiMAX mesh network is based on Wireless Mesh Network (WMN), a special kind of Mobile Ad Hoc Network (MANET) with the WiMAX technology as a wireless part of the network.

WMNs have special characteristics such as dynamic self-organization, self-configuring, self-healing, high scalability and reliable services and are able to balance traffic and provide support to drop connections to fixed or mobile users (Mudali *et al.*, 2009). These are convenient characteristics for a network in rural areas where constant network management may make the business unprofitable. The basic topology of an IEEE 802.16 mesh network consists of two parts namely; Base Station (BS), a coordinating node and Subscriber Station (SS).

2.4.2. Broadband Island

As a move to further address the access gap, Nungu *et al.* (2008) developed an Island model to make use of unutilized TANESCO fibre optic network that existed between Bunda and Serengeti districts in Mara Region, Tanzania. In this model, only local communication among government offices, education, healthcare, and other entrepreneurs were considered. This broadband island had a narrowband VSAT connection to the Internet but the main focus was local connectivity. In similar set ups, unutilized networks can be used to provide not only voice but also broadband services to users around that network. Promotion and mainstreaming the broadband island model can benefit many at a reasonable cost.

2.4.3. Nokia Siemens Village Network

The Nokia Siemens Village Connection (NSVC) system is PC based, using IP (Internet Protocol), with backhauling delivered mainly by satellite. Each Access Point is supported by a regional Access Centre that can support up to 200 Access Points with each Access Centre providing network coverage for up to 14 000 subscribers (NSN, 2008). The NSVC uses a different business model in which all the village internal calls are connected locally and only rest of the world calls go out of the village network as shown in Fig. 6 (NSN, 2008). This significantly lowers CAPEX and OPEX costs by avoiding unnecessary use of bandwidth and hence the reduction in connection cost. The other cost serving technique is through the use of antenna on village buildings instead of installing masts which normally add cost. This cost effective network has been successful in India where the rural population has started to enjoy the services just like in urban centers. Because of lack of power in rural areas the village connection networks make use of low capacity solar panels on the customer's house.

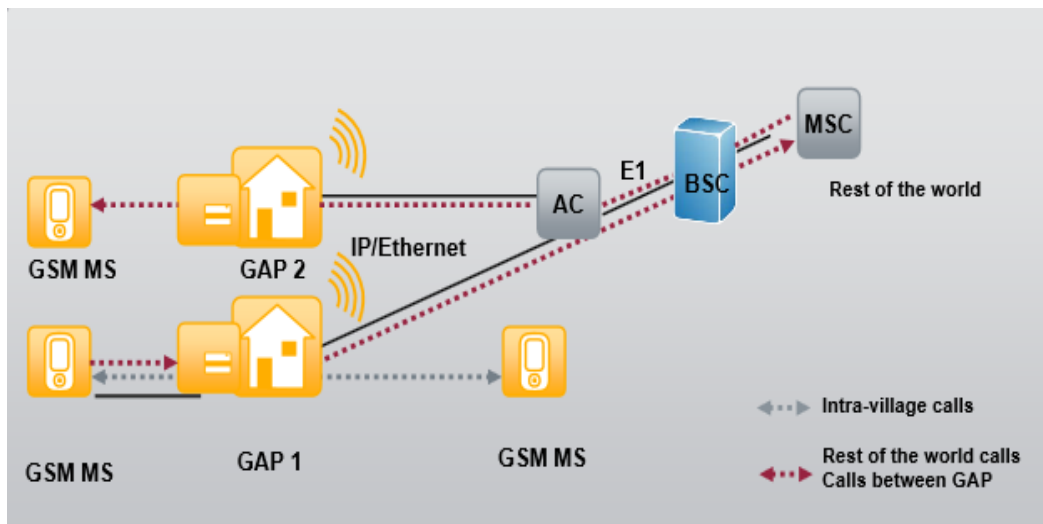

Figure 6: Nokia Siemens Village Network.

In Tanzania, Nokia Siemens Networks and Vodacom Tanzania Limited entered into an agreement to implement the Nokia Siemens Networks Village Connection Solution (NSN, 2008), as an innovative and unique solution to resolve the challenge of rural coverage to deliver cost effective network capacity in terms of low CAPEX at a low OPEX. The solution was set to start in 2008 with a trial implementation and later be extended elsewhere in the country.

This arrangement has a promising future but at the time of writing this dissertation there was no progress report on the project in Tanzania. The implementation ended only on trial stage. Although the reasons are unknown, it can be attributed to lack of customers interested in the service due to the fact that they were not involved in project planning as noted in Simba (2012) and Nungu *et al.* (2011a).

2.4.4. Rural Netco Shared Broadband Model

The Rural Netco Broadband Model is a wholesale model operating in Tanzania from which the operators buy capacity to provide services to their customers. The company has already launched commercially with Vodacom. In December 2018, Vodacom had a market share of 32% compared to Tigo (29%), Airtel (25%), Halotel (9%), Zantel (3%), TTCL (2%) and Smart (0.32%) as indicated in the TCRA quarterly report (TCRA, 2018).

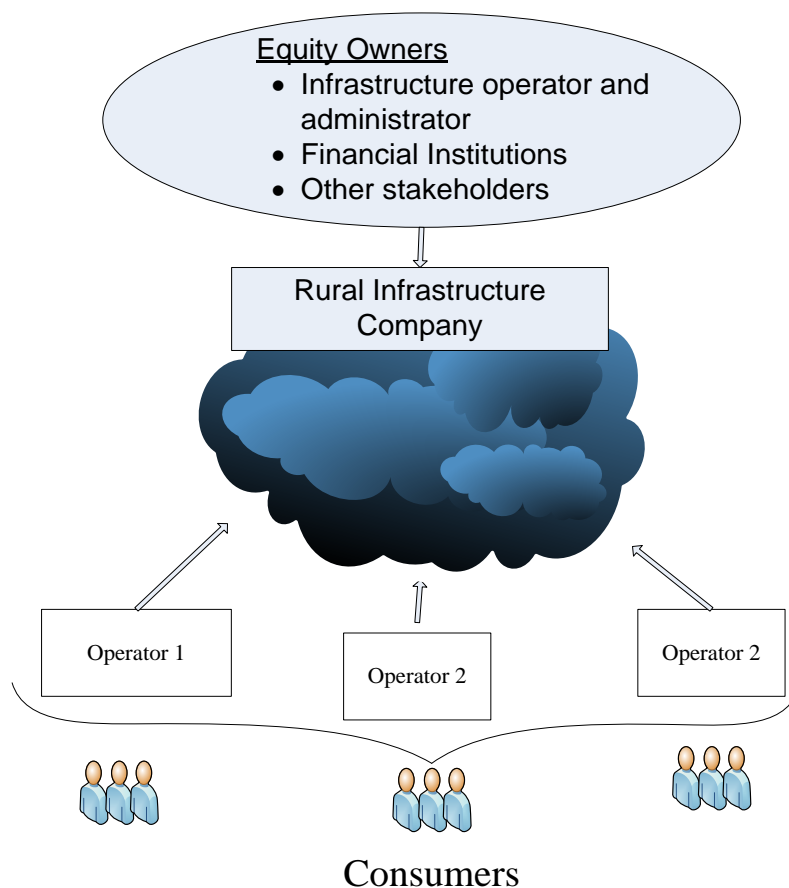

Figure 7: Rural Netco Shared Broadband Model.

According to the BE Weekly magazine (Daynes and Boyle, 2016), Rural Netco is currently providing coverage to 23 regions in Tanzania. This is a huge coverage if the remaining

operators can enter into an agreement and cover those areas with value added services. The Rural Netco covers a given area and lets the operators use their network to provide services to users as shown in Fig. 7. This model is attractive in a way that it allows the company to benefit from economies of scale while contributing to the realization of co-location and sharing of resources that is stipulated in the Electronic and Postal Communications Act (EPOCA) (TCRA, 2011). As a result, the overall investment cost to the operators is reduced and this ultimately lowers services prices.

2.4.5. Television White Spaces (TVWS)

Television White Space (TVWS) is the recent technology that uses the unoccupied television (TV) frequency band for non-broadcasting services such as broadband services. TVWSs exist in the spectrum primarily used for digital terrestrial TV broadcasting, that is, 470 MHz to 694 MHz (Manasseh, 2016).

Recently, TVWS are recommended for use in rural areas due to associated low cost of operation and a substantial amount of bandwidth for broadband services; they can provide broadband connectivity of up to 16 Mbps (Roberts *et al.*, 2015). A typical example of the implementation of TVWS is the project that has connected 5 schools in the rural Mankweng Township at a distance of around 10 km around the University of Limpopo in South Africa (Masonta *et al.*, 2015b). In this particular project, 31 tablets, an overhead projector, and smartphone were donated to each of the five schools to facilitate eLearning delivery. There is another good example in Tanzania whereby Microsoft in collaboration with The Commission for Science and Technology (COSTECH) and UhuruOne, a Tanzanian ISP organized a project to provide affordable wireless broadband access to university students and faculty in Dar es Salaam using TVWS radios from 6Harmonics. In this project, 4 higher learning institutions are involved and this partnership enabled UhuruOne to offer a laptop or tablet, wireless broadband connectivity, and applications and services to cover a student population of about 50 000 at four universities: the Institute of Financial Management, the Dar es Salaam School of Journalism, the Institute of Social Work and The Open University of Tanzania (Roberts *et al.*, 2015).

Apart from providing broadband connectivity in rural and underserved areas, TVWS can effectively improve spectrum utilization (Maleki *et al.*, 2015; Oh *et al.*, 2016) and alleviate spectrum scarcity and when compared with Log Term Evolution (LTE) for rural broadband,

TVWS is more cost effective. However, very few countries have fully regulated and adopted TVWS for broadband services. In countries like Tanzania, Ghana, Kenya, Botswana, Namibia and South Africa, trial projects have been implemented by Microsoft in collaboration with local Service Providers to support various media protocols, such as streaming videos, emails, FTP, Skype voice and video conferencing, and high-speed VPN services (Roberts *et al.*, 2015).

Figure 8 shows a TVWS network architecture which comprises of the 802.11 b/g/n/ac Wi-Fi access points (APs), which connect directly to the TVWS customer premise equipment, or CPE using standard Cat5 or Cat6 cable. The CPE communicates with the TVWS base stations (BS) through a TVWS air interface protocol, e.g. IEEE 802.11af, which can be located within several hundred meters of the CPE or kilometers away. The TVWS radio attaches behind the antenna to the same pipe mount and an RF jumper connects to the antenna while Cat5 cable drops to the Wi-Fi AP or Ethernet switch (Roberts *et al.*, 2015).

When it comes to what technology to be used in connecting a specific area in rural areas, a number of factors need to be considered to come up with the right one for the area, namely: type of services, ownership and purchasing power of the people in that area.

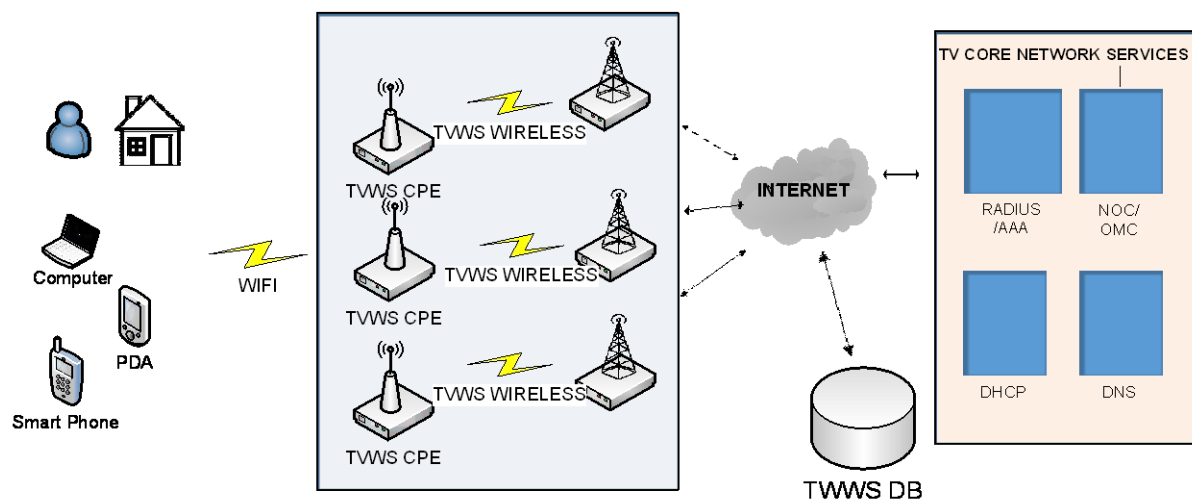

Figure 8: TVWS network Architecture.

2.5. Initiatives to Achieve Broadband Connectivity

A number of initiatives to achieve the goals of Tanzania Vision 2025 and the objectives of NICTP-2003 have been implemented and together have helped in some ways to reduce the

digital divide. Some of these initiatives are the telecentres, the NICTBB project and the UCSAF. Although, when the telecentres were first instituted, the main service considered was voice service, the current telecentre model considers broadband connectivity because the technologies to facilitate that are available. This is why the ITU/UNESCO report of 2013 (ITU/UNESCO, 2013) recommends telecentres as a means to address broadband access barriers in areas with low population density and low purchasing power. In the next section, each of the initiatives is briefly presented and discussed.

2.5.1. Telecentres

Telecentres are places where shared access to ICT and enabled services are available and are used to bridge the digital divide between rural and urban areas (Kapondera and Hart, 2016). Telecentres were initially introduced in 1998 for developing countries as a means to achieve universal access and hence socio-economic development. In Tanzania, Sengerema pilot telecentre, shown in Fig. 9 was implemented in Mwanza region in 2000. It was expected that installation of such centers would increase with time but ten (10) years later only 22 telecentres were reported to exist (TCRA/BIID/TTN, 2011) which is very small number compared to the number of areas lacking such services. This means the expected impact of telecentres were yet to be realized (Ngowi *et al.*, 2015). Looking at the investment structure of such initiatives most of which were donor-funded and at the end of the funding duration most of these telecentres failed to operate despite the inclusion of secretarial and other services as part of the diversification strategy to sustain the center's performance.



Figure 9: Sengerema, Mwanza Telecentre.

Although their inception in Tanzania was well before the institution of the National ICT Policies (NICTP-2003 and NICTP-2016), telecentres have always been recommended for shared access and means for aggregating traffic in areas where customers are sparsely populated and purchasing power on an individual basis is low hence achieving the universal access remained a challenge.

At the time the telecentre initiative was being introduced for rural and remote areas in 1998, the access technologies were mainly VSATs due to their being located far from the reach of wired and other networks. With VSATs, the main challenge was annual satellite charges even when the link is not used. With the positive changes in technology coupled with high capacity, affordable and reliable networks, telecentres of today are expected to perform even better. This is why to date the ITU recognizes telecentres as one of the strategies to overcome access barriers to universalizing broadband in low population and places with low purchasing power (ITU/UNESCO, 2013). This means countries such as Tanzania need to consider mainstreaming the telecentre model for low purchasing power users if it has to achieve broadband connectivity for all.

2.5.2. The Tanzania National ICT Broadband Backbone (NICTBB)

In order to realize the vision of the NICTP-2003 "Tanzania becoming a hub of ICT Infrastructure and ICT solutions that enhance sustainable socio-economic development and accelerated poverty reduction both nationally and globally", the government through the NICTBB project set itself to connect all its administrative regions and districts to create a high capacity and reliable national broadband infrastructure so that they have an access to international and regional broadband infrastructure as well as the sea cables landing on its shores (MCST/CITCC, 2010). This alone is enough to allow other initiatives to be undertaken once the relevant infrastructure is in place. The project is set to be implemented in 5 phases. In line with the NICTBB project, a Broadband Access Connectivity Project has been designed to establish regional and district area networks and Community or Citizen Information/Knowledge Centres (CICs) or (Kiosks and Telecentres) by utilizing the Postal and TTCL Networks (MCST/CITCC, 2010).

At the end of its 2nd phase in 2011, The NICTBB had an Optical Fibre Cable (OFC) route length of 7560 km connecting 24 Region centers in Tanzania Mainland, also connecting Pemba through TANESCO cable between Tanga and Pemba. Telecommunication operators

and ISPs were able to connect to the network which drastically reduced the connection cost of most services from voice to the internet and other services.

In its 3rd phase, the NICTBB centered on four main components which are [24]: (a) construction of additional OFC links to achieve a mesh OFC transmission networks; (b) construction of regional and district OFC transmission networks; (c) construction of an IP-layer of the NICTBB and a national Internet Data Centre (IDC) network facility of high standard; and (d) Implementation of additional Internet-based connectivity systems for the government to extend the ongoing e-Government project such as ERNET, e-Schools Network, e-HealthNet and CICs to local governments (MCST, 2013). It was reported that the service charges per Gigabyte (GB) had dropped by 75% from TZS 36 000 in 2009 to TZS 9000 in 2013. A similar drop in charges was achieved in mobile phone calls per minute charges from TZS 147 to TZS 62 (MCST, 2013). This makes communication affordable to most of the people where this connectivity is available.

During the reported research work, it was discovered that some users (businesses and institutions) in remote, rural and urban-underserved areas are connected to the fibre network with huge capacity terminated within the vicinity of the rural and urban-underserved unconnected users. This suggests that it is possible to tap from such connectivity as a means to utilize the links at the same time serving the users who would never bring that connectivity to their areas on their own due to the associated costs. This is because the main cost of bringing the connectivity is already paid for. An example is the 14 km fibre link from Arusha town to the Nelson Mandela African Institute of Science and Technology (NM-AIST) in Arusha campus carrying 1 Gbps capacity while the schools and other organizations around NM-AIST are not connected. This connectivity can be extended to surrounding users using wireless technologies such as MMDS or WiMAX (Frank *et al.*, 2013).

2.5.3. The Universal Communication Services Access Fund (UCSAF)

UCSAF is one of the initiatives that was created in Tanzania to address the access gap existing in the country between rural and urban areas. It is a follow up on the World Summit on Information Society (WSIS) agenda. The idea is to subsidize investments to unprofitable rural and urban-underserved areas, which lack incentives to investors. Through members of parliament (MPs), it was possible to identify 2175 villages in Tanzania for which the fund needed to consider.

The fund issued two subsidy tender bids for the provision of basic voice telecommunications services under contracts: (UCAF- 2012-1 and UCAF-2013-1) covering a total of 223 wards and 1284 villages. In Tanzania, a ward is an administrative structure consisting of several villages in rural areas or streets in urban areas. Universal Access plan is expected to cover a total of 340 wards with about 2500 villages in total. It can be noted that both tender bids require operators to provide basic voice services to these rural areas. Although voice service is one way to development but yet still, broadband connectivity is as important considering real-time applications that require more than just mobile voice services. However, with the availability of Fibre Network coverage to the district level and the wireless coverage that is being established, it is possible to extend the broadband connectivity through a combination of various technologies that are already available in the market. For instance, the recent launch of 3G and LTE mobile broadband services can easily build on the coverage already in place.

From the report by UCSAF on "Coverage, Population and Land Scan Data for Selected Wards", some ward villages were without telecommunication services. Figure 10 shows some of the selected wards with a bigger percentage of the geographical area uncovered, most of which 100% were not covered by any network which means even the population was uncovered with more or less percentage as shown. These villages were selected based on the total areas uncovered by any telecommunication service at the time of research as presented in the report (UCSAF, 2013). This is a serious situation considering that Tanzania wants to graduate from a Lower Income Country to a Middle-Income country by the year 2025, which is expected to be achieved through ICTs (TDV2025, 2000).

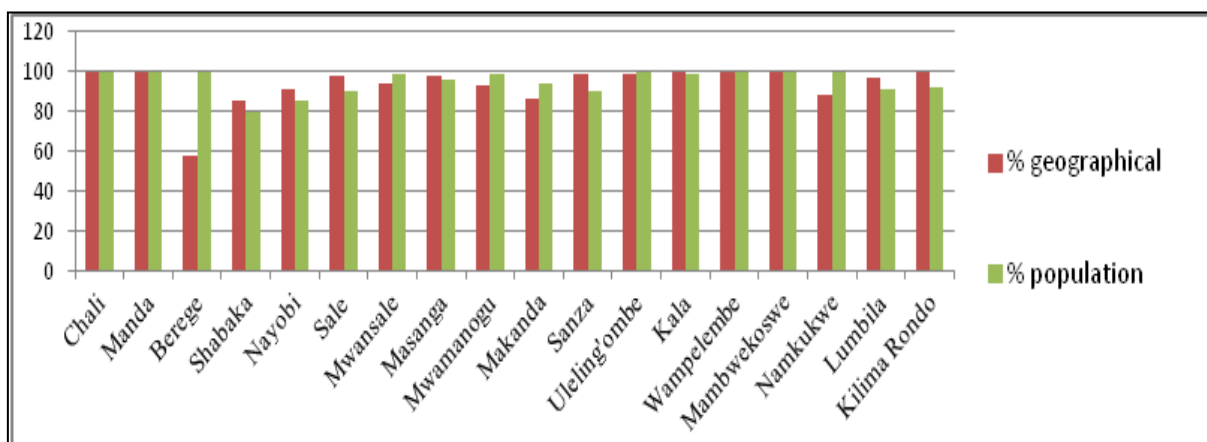

Figure 10: Geographical and population uncovered percentages for selected wards.

2.6. Infrastructure Readiness

It is generally understood that infrastructure is what drives information society such that lack of it makes the goal of achieving an information society as stipulated in the NICTP-2016 (URT, 2016) a daydream. One of the policy statement states on ICT infrastructure that:

"The Government will ensure that a reliable state of the art ICT infrastructure, of adequate capacity, high-speed and countrywide coverage is developed."

This policy statement has been a motivation for the Government of Tanzania to construct the Optical Fibre Cable (OFC) network, the NICTBB. Building such advanced network with high-speed capacity has been described by many as "the great infrastructure challenge of the 21st century" (Jones, 2006). Therefore, Tanzania is one of the countries that have addressed that challenge by building the state of art NICTBB with Points of Presence (PoPs) at all administrative regional and district headquarters. This network provides connectivity to the international infrastructure through four International submarine cables: SEACOM, EASSy, SEAs and TEAMS providing an abundant bandwidth, fast and affordable broadband connectivity to the country (MCST, 2013).

In addition to the OFC infrastructure covering the whole country at district level, there are other private mobile and fibre networks available in the county owned by telecommunications operators and various organisations such as the Tanzania Electric Supply Company (TANESCO) and Ministry of Water (MoW), which are currently being used in combination with the public networks in various socio-economic development projects. Example, the Bunda-Mugumu access network is being provided through an OFC installed by TANESCO with the fibres carried in the ground wire known as optical power ground wire (OPGW) along the 33 kV power line (for supervision, control and data acquisition purposes) and the Wami-Chalinze network project through the MoW optic fibre network (a water flow monitoring and accounting systems) (Kondoro and Nungu, 2006; Nungu *et al.*, 2008; Simba *et al.*, 2009).

Furthermore, the Government of Tanzania through its Ministry of Works, Transport and Communication (MoWTC) envisions a knowledge-based Tanzanian society with the capacity and capability to harness Science, Technology, and Innovation for the transformation of the economy that is sustainable and globally competitive. With this vision, it is clear that ICTs can facilitate reaching the majority (about 70%) of Tanzanians living in rural areas to be part

of this vision. This is why the Government charged the Ministry to construct the NICTBB as a means to solve the issue of telecommunication infrastructure (MCST/CITCC, 2010).

In line with this, the NICTP-2016 emphasizes ensuring all installed ICT infrastructure and capacity is utilized effectively and contributes to resilience and redundancy. Therefore, there is a need for a plan on how to utilize all installed capacity such as the NICTBB and the UCSAF projects to achieve learned learning society as stipulated in Tanzania Vision 2025, in which case digital divide in different geographical locations is minimized if not eliminated.

However, the ICT Infrastructure is associated with the availability of other essential services/ infrastructure such as electricity supply, roads and other basic economic services and social necessities; meaning that any solution to achieve connectivity in such areas needs to consider presence or absence of such services.

Even after all necessary ICT infrastructure has been in place still willingness and readiness, leadership and ownership will be a holdup of service provision to users in the urban-underserved and rural areas. However, with the Public Private People's Partnership (PPPP) model proposed in Simba (2012) as an implementation strategy for sustainable broadband rural connectivity solution, it is possible to mitigate such challenges due to the fact that from the very beginning all the parties are involved so that each of the member/parties is interested to see the projects to the end and play part in each step where involved.

2.7. Policy Readiness

Various Tanzania policies, regulations, and national strategic plans recognize the importance of broadband connectivity either through, set regulations and frameworks, encouraging best ways for broadband connectivity or encouraging ICTs in various sectors in the country. Tanzania does not have a Broadband policy which should be a vital part of broader ICT policy strategies (OECD, 2008), like its neighboring country Kenya and the rest of developed countries. However, the available policies, regulations, strategies and frameworks are sufficient to allow broadband connectivity to reach every citizen. For instance, the National ICT policy of 2016 (URT, 2016) envisions:

“Tanzania with economically, socially and culturally enriched people in ICT-enabled knowledge society.”

This policy targets specifically broadband connectivity through policy statements:

“The government will (URT, 2016):

- i. Ensure conducive environment for collaboration of public and private sector in exploring various means of financing access to broadband services;*
- ii. Ensure availability and accessibility of reliable and affordable broadband services countrywide.”*

This focus on bridging the digital divide through the UCSAF has started with the provision of voice services to rural and urban-underserved areas. Notably, EPOCA regulates the co-location and sharing of network facilities as a means to bring down the access charges among providers so that many people can access the services. This has allowed for the successful implementation of spectrum sharing as means to effectively utilize the scarce resource.

In the ITU/UNESCO broadband report of 2013, Tanzania is listed among the countries that have broadband plans (ITU/UNESCO, 2013). This is due to the implementation of the National ICT Broadband Backbone that is intended to provide high-speed connectivity to the whole country.

Therefore, Tanzania is ready to provide and promote the provision of universal access to broadband services countrywide through both private mobile broadband projects (Mobile operators), Private-Public Projects (PPP) and other initiatives as the policy environment is in support of the same.

2.6. Conclusion

Discussed in this Chapter, are the models available for rural areas last-mile connectivity, infrastructure, policy readiness and initiatives focusing on rural connectivity in Tanzania. It has been noted that although Tanzania has no specific broadband policy, the current national strategies and ICT policy and other frameworks are sufficient to bring broadband services to rural and urban-underserved areas. Therefore, the infrastructure is to some extent satisfactory if utilization of available private and public networks is extended to rural and urban-underserved areas. Other factors such as ownership and public-private partnership programs need to be considered.

CHAPTER THREE

UTILIZATION OF BROADBAND CONNECTIVITY IN RURAL AND URBAN UNDERSERVED AREAS: THE CASE OF SELECTED AREAS IN ARUSHA- TANZANIA³

Summary

Utilization is a key aspect in the management of any societal resource not only when it is scarce but in all cases to allow for optimum benefits to be accrued to everyone in the society. Internet or international bandwidth, which is a rare commodity especially in rural areas, is hardly available where needed at the same cost and quality due to various reasons. Tanzania, as a case study, is among countries that have invested much in international, national and metro backbone networks, but still, there are areas without or with inadequate internet access services implying a significant utilization problem. In this Chapter, we present as a case study, the status of broadband connectivity in selected rural areas in Tanzania (Arusha) and the status is used to make recommendations for optimized utilization of installed capacity.

3.1. Introduction

Significant improvement in internet access connectivity has been reported worldwide (Schuman and Kende, 2013), through various means such as telephone or smartphone penetration, coverage of mobile connectivity, number of people owning smartphones, a decrease of digital divide and others. In some areas, this improvement has translated into reduced charges, improved quality of service and user experience to the communities but not everywhere in the world. Furthermore, internet services are not available everywhere despite a significant reduction in price (Wyche and Steinfield, 2016). The situation is more evident in rural and isolated areas in developing countries that have always been characterized by a low number of subscribers of telecommunication services and this has continued to be a hindrance to investors to bring the services to such areas. Generally, in some countries, the problem is not dependent on geography only, but the main constraints as mentioned in Simba

³ This chapter is based on the paper:

Byanyuma, M., Yonah, Z. O., Simba, F., Trojer, L., 2018. Utilization of Broadband Connectivity in Rural: The case of Selected Areas in Arusha-Tanzania, in: International Journal of Computing and Digital Systems. University of Bahrain.

et al. (2012) are lack of Internet Exchange Points (IXPs) and Internet Service Providers (ISPs) that deliver access to end users. An IXP is a physical infrastructure through which ISPs exchange internet traffic between their networks thereby reducing latency and delivery cost of their services. The primary purpose of an IXP is to allow networks to interconnect directly and locally, via the exchange, rather than through one or more third-party networks which usually require international connectivity. The advantages of the direct local interconnection are numerous, but the primary reasons are cost, latency, and international bandwidth.

The significant increase in high capacity and comparatively cheaper terrestrial networks mainly based on optic fibre cables (OFCs), has significantly reduced the cost of connectivity (Pazi and Chatwin, 2013). This has been possible due to the replacement of satellites, which are very expensive, have higher latency and comparatively low capacity. Despite the increase in high capacity OFC networks, few private and government organizations pay extra cost to get such services. On one hand, broadband connectivity in rural areas is mostly for government and a few private organizations leaving the majority unconnected hence making the digital divide more pronounced in those areas. On the other hand, mobile network operators (MNOs) are proud to announce that they have covered all areas including the remote ones and competition has brought airtime charges down including broadband services in some areas. This is offered in daily, weekly or monthly bundle plans that come with SMS, airtime and data volumes at a reasonable price all over the country but still these bundles benefit only those who are closer to a high capacity portion of the networks and have modems or smart devices to take advantage of such service availability opportunities. For example, a typical cheapest monthly internet bundle of TZS 10 000 provides up to 10 GB data volume (Special University package by Halotel Network operator although the actual cost of bandwidth outside that arrangement is 30.72 TZS./MB (Halotel, 2017). There is also off pick offers like the night data packages that offer significantly large volume at a very small cost. It can be noted that those without smartphones and out of reach of broadband mobile networks will not benefit from such an opportunity hence present a form of utilization problem. In some areas there is everything in place; the coverage, the broadband capacity but due to various reasons, the communities are not using the service at their disposal.

In terms of connectivity, several initiatives have been undertaken in Tanzania including the creation of community multipurpose telecentres (Mbarawa, 2010), subsidizing the service

provision through UCSAF and connecting groups of people such as schools in projects such as “connect a school.” (Simba *et al.*, 2011) and building the OFC-based national ICT broadband backbone (NICTBB) (MCST, 2012; Simba *et al.*, 2012). Some individuals and organizations have proposed means such as broadband islands utilizing the fibre links to get access to an intranet (Nungu *et al.*, 2008), a case of Serengeti Mugumu networks utilizing the Tanesco fibre cables to connect the users in the neighborhood. It can generally be agreed that broadband connectivity in Tanzania, where its national fibre network is laid across the country with points of presence in all district headquarters and mobile networks covering almost the whole country, is no longer a problem. Similarly, due to the availability of internet access connectivity and the corresponding international bandwidth through submarine cables such as SEACOM, EASSy and TEAMS, the bandwidth problems of availability and affordability will soon become history (Mtebe, 2013). However, when you go beyond the district headquarters you will find this statement false.

The Tanzania National Information and Communication Technology Policy (NICTP) of 2016 (URT, 2016), clearly acknowledges this fact that there are no appropriate frameworks for deployment and utilization of ICTs infrastructure for maximum economic benefits coming with these ICTs. This is the reason the study reported in this Chapter was undertaken, to establish the exact problem and to investigate possible solutions to address it accordingly

3.2. Literature Review

3.2.1. What is Utilization

In this research, we consider utilization of a resource which is defined as making use of or finding a profitable or practical use of a given resource. It is a ratio used to compare a current usage level against a maximum potential level of a given resource (Investopedia, 2016). This means that any way to make use of available capacity for the benefit of many at a reasonable cost is the utilization of capacity.

In the case of Tanzania, there have been various initiatives to bridge the digital divide, including the implementation of the NICTBB and the mobile cellular network subsidization for rural areas by the UCSAF, but most of these efforts are underutilized. Most of the stakeholders in the Telecommunication Industry and those dealing with users that need connectivity for development such as the Ministry of Education, the Commission for Science and Technology (COSTECH), Tanzania Education Authority (TEA), UCSAF and the

Ministry for Science and Technology, have programs/initiatives to connect schools, institutions and various communities. Similarly, the mobile network operators in Tanzania such as; Vodacom, Halotel, Tigo and TTCL, have programs to connect the rural and urban-underserved as part of their Corporate Social Responsibilities and these programs are uncoordinated. In a long run, these efforts may result into duplication and wastage of efforts and resources. To address this, something needs to be done, in particular, the utilization of all broadband connectivity in the vicinity of potential users, that is, considering all areas with the nearest connectivity first. So far, utilization of such resources whose part of investment cost has already been paid for by anchor customers is one way of bringing broadband connectivity to many in the shortest time possible. These anchor customers are market-leading companies who are crucial to the success of broadband connectivity. However, a regulatory framework is required to motivate any such organization with underutilized connectivity link to be part of the rural and urban-underserved connectivity projects by allowing a broker to use the facilities as long as they do not affect their subscriptions and service quality.

Utilization of connectivity in rural areas is expected to help a lot in bridging the digital divide and improving social services like delivery of health care, agricultural extension and educational services. Use of ICTs has demonstrated that it is possible to provide all types of services such as blended learning (Mtebe, 2013) to make efficient utilization of scarce human resource in teaching and telemedicine for the provision of healthcare services in understaffed areas (Qiao and Koutsakis, 2011). In the following section, literature on utilization of broadband connectivity in rural areas are reviewed and typical cases showing the underutilization of installed capacity in rural areas in Arusha region, Tanzania are presented.

3.2.2. Lack of Awareness or Low Literacy Rate

Lack of knowledge is one of a barrier to internet usage in learning and teaching (Mosha and Bea, 2014). This is the same situation with mobile broadband, only those who have knowledge of its importance will be willing to pay for and use it. Lwoga (2010) contends that low literacy rate is a contributor to low use of internet services. In some cases, where airtime bundles include bandwidth as a bonus, without knowledge and or awareness, that resource expires unused. This adds to a number of people not utilizing the broadband connectivity available in their locality. Considered in this case, is the utilization of bandwidth as a percentage of capacity subscribed to the available link capacity assuming the subscribed capacity is not shared which is not the case in practice.

3.2.3. Network Reliability, Coverage and Affordability

The broadband network coverage is limited in rural and urban-underserved areas in two ways; one is that, the wired fibre access network like the Fibre to the Home (FTTH) is still expensive for the individual majority. Secondly, the wireless cellular network coverage in rural areas provides limited capacity for broadband connectivity although this could be upgraded to high capacity technologies at additional cost. Figure 11 shows the mobile network coverage by Halotel (TanzaniaInvest, 2016) and Fig. 12 shows the mobile network coverage by Vodacom Tanzania (Vodacom, 2018).

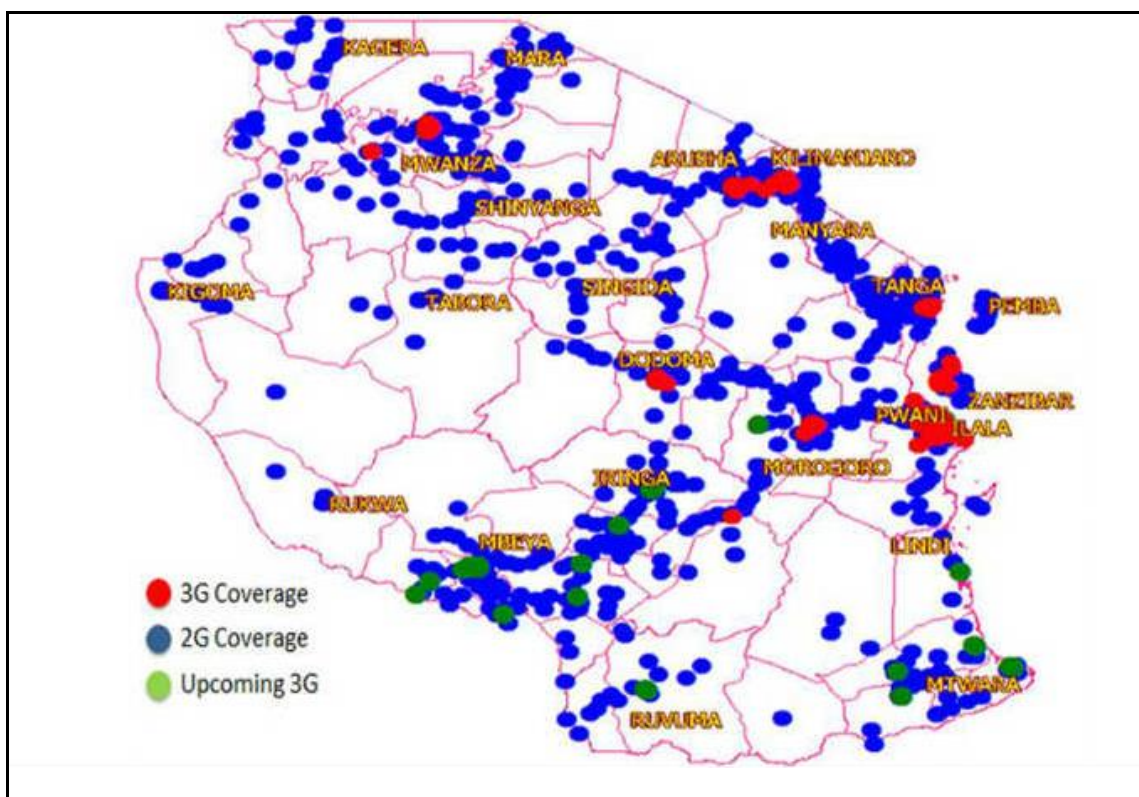

Figure 11: Halotel Coverage Map as at the end of 2016.

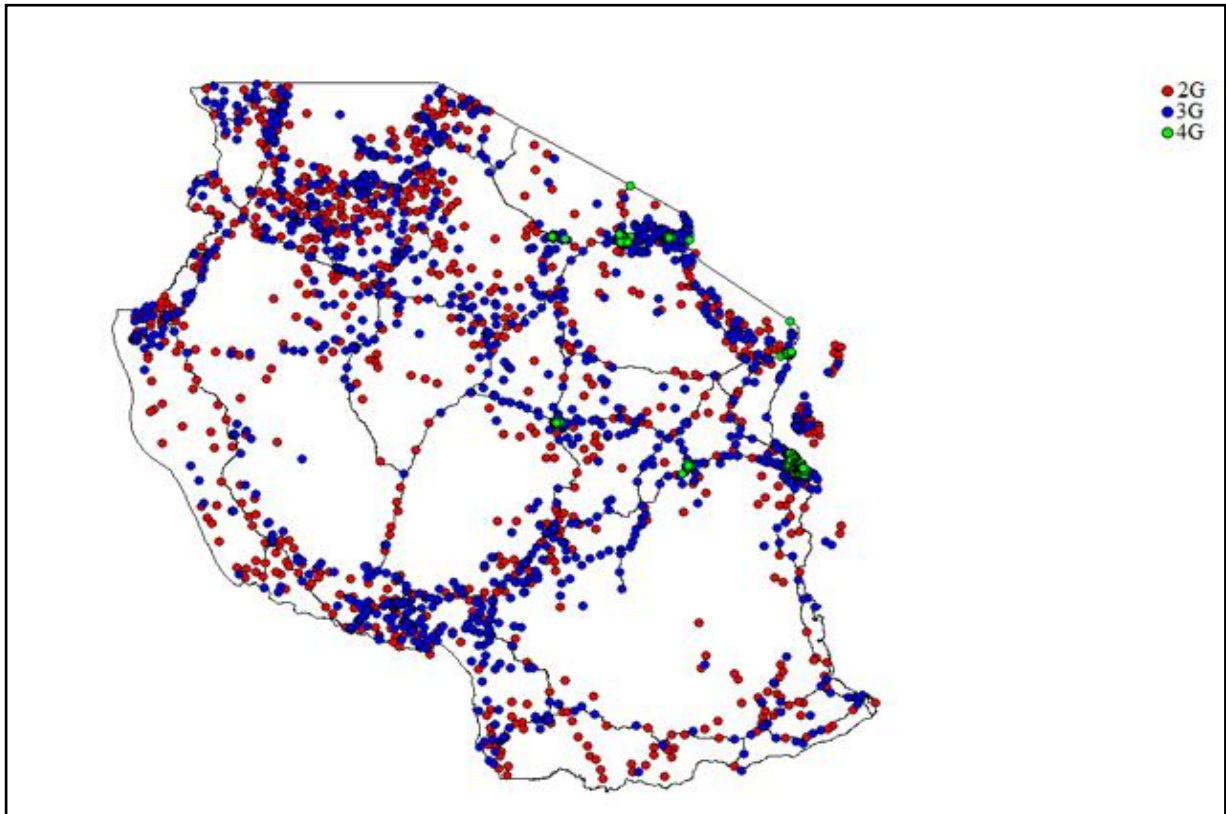

Figure 12: Vodacom Coverage Map in 2018.

3.2.4. Affordability of devices and Air charges

Affordability is generally seen as depending on overall income levels and overall telecommunications tariff levels (Milne, 2006). In terms of income, Tanzania and other developing countries have a good number of communities with low purchasing power to be able to own devices and pay for air charges to stay online. The implementation of submarine cables and the NICTBB project has brought down the communication charges but the rural income is still insufficient. This is accompanied by the problem of lack of electrical power which is common in rural and urban-underserved areas.

There are a number of initiatives aimed to bring power to rural and urban-underserved areas in Tanzania through projects sponsored by entities such as the Rural Electrification Agency (REA) through the use of normal electrical power or renewable energies like the solar and wind energy. Therefore, if energy costs are added to the cost of devices and airtime, it becomes even impossible for a normal user in those areas to use the technology. This again accounts for a good number of people who do not use technology because they cannot afford to own devices, pay for airtime and power charges.

From both maps, a big part is covered by a 2G technology that offers mainly voice and limited data service (Shukla *et al.*, 2013). In terms of 3G, most areas are yet to be covered. Therefore, for those users residing in such areas, they are not able to use the broadband network capacity available in the country due to the last-mile/access technology that is limited in capacity.

3.3. Broadband Connectivity

Broadband connectivity has always been a challenge to most of the countries around the world especially developing countries (Chavez *et al.*, 2016; Eduardo and Vargas, 2014; Nungu *et al.*, 2011). Various studies have been centered on finding cost-effective last-mile technologies to connect all especially, those in the rural and urban-underserved areas (Byanyuma *et al.*, 2013; Hammond and Paul, 2006; Schneir and Xiong, 2016; Simba *et al.*, 2012; Weiss *et al.*, 2016)

Currently, however, in most cases connectivity is not a problem because governments, national and international organizations have been consistently working on devising means to bridge that gap through funding the studies on the area, subsidizing services provision in unprofitable areas through universal access funds (Eduardo and Vargas, 2014; Lewis, 2013) and putting forward the right and up to date policies and regulations (Briglauer, 2014; Olwal *et al.*, 2013).

Consider for example in Tanzania, there is a high capacity connectivity providing both international and national connectivity although last-mile connectivity (the last link from a network to the end user) is still a problem in underserved areas such as rural and small towns (Kowero, 2012). The reasons for this inadequate connectivity in these areas are low purchasing power, uncoordinated efforts, lack of ownership of community connectivity projects, lack of management skills and involvement, low return on investment; hence lack of business incentive and uncoordinated utilization of available resources. Integration of ICT in socio-economic activities involving many people may change the level of purchasing power in a given community; as through ICTs, many economic and employment opportunities are expected and hence increased incentives to investors and return on investment in those areas. Good examples are countries such as Korea, which is ranked the world's most advanced ICT economy, followed by Sweden, Denmark, Iceland and Finland. These countries have built

high-speed connectivity networks to facilitate efficient and effective use of ICTs applications for increased socioeconomic growth (see Fig. 13) (ITU, 2012).

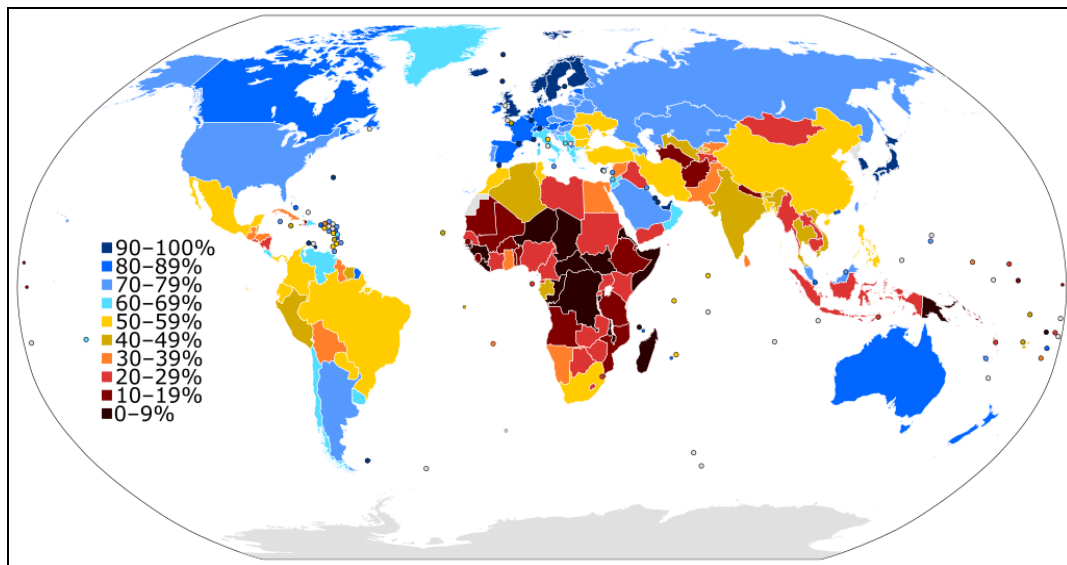

Figure 13: World Internet Penetration in 2012.

The main parts of Africa, on the other hand, are the least users of ICTs derived from the ICTs penetration as shown in Fig. 13 (ITU, 2012). Although this is based on the 2012 data, the situation has not changed much to date. We can even see from the ITU recent data of 2005 to 2016 (ITU, 2017a), in Fig. 14 showing an average Africa penetration (individuals using the internet) as low as 21.8% compared to 79.6% of Europe. These correlate with the map shading in Fig. 13.

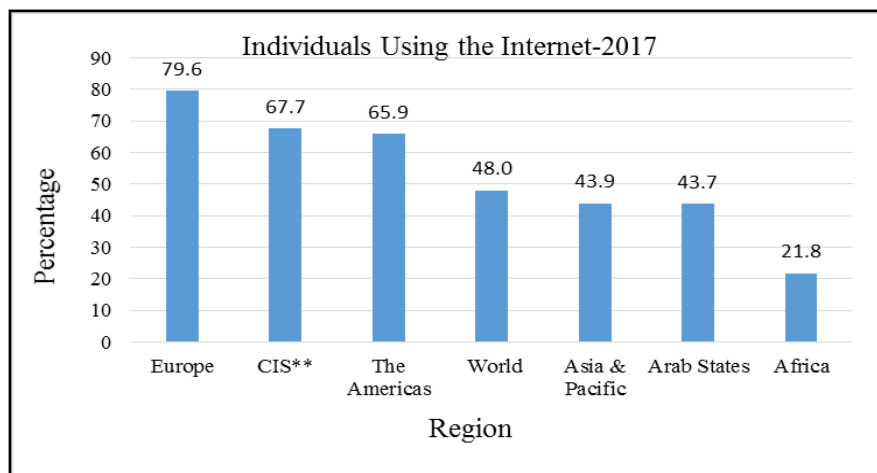

Figure 14: Internet Penetration (Individuals using the internet) (ITU, 2017b)

These statistics indicate a very high access gap or digital divide and is in line with the poor economic progress of such countries. However, within those countries where there is a low percentage of the total population that use the internet, there are few areas (the urban and city centres) that are better off compared to rural and underserved ones, as they are comparatively more attractive to investors.

3.4. Methodology

In this section, the study area and method used to undertake this study is explained.

3.4.1. Study Area

The study was conducted in the Arusha region in Tanzania, where five (5) districts were involved namely; Karatu, Longido, Monduli, Meru and Ngorongoro. The study focused on broadband services in these districts. The study employed purposive sampling to select the survey areas.

3.4.2. Data Collection

Interviews were conducted with Internet Service Providers (ISPs) to identify among other things, broadband users residing in rural areas and the technology used to connect them. After identifying these rural areas with broadband users, field visits were used to establish installed capacity and utilization of the same.

Literature review/desk study was conducted to get more knowledge on the subject matter. Initially, the aim was to investigate the telecentres served by the ISPs but it was found later that there were no telecentres in Arusha intended to serve the rural communities. This notion of the existence of telecentres in regions was learnt from past literature that telecentres were recommended to be implemented all over Tanzania and other developing countries as cost sharing mechanism to reach rural areas in terms of voice, data and other services. The main idea was to use a shared service to aggregate traffic for sharing high capacity backhaul services available in the area which is still a viable idea if it is modeled in a right way (Naik, 2011).

3.4.3. Calculation of Utilization

Capacity utilization is a ratio used to assess a company's operational efficiency. This ratio is also used in a broader perspective in a way that it can measure the realized potential output

which can show the company how much they can still utilize. It can therefore be calculated by dividing the actual output to the potential output multiplied by 100 (Wallstreetmojo, 2018).

Similarly, in this study, the utilization of installed capacity was calculated as a ratio of subscribed bandwidth capacity to the total installed link capacity at the given service area. This assumes that the subscribed capacity is 100% utilized, if it does not take into account the issues of overbooking and contention ratios where utilization of network may consider overbooking to take into account the idle time, the time at which the network is not used.

Equation 3.1 shows the formula that was used to calculate the utilization of broadband link capacity.

$$Utilization = \frac{User\ Installed\ Capacity}{Total\ Link\ Capacity} \times 100 \dots\dots\dots 3.1$$

The following section presents the study results and discussion.

3.5. Results and Discussion

In this section, the data collected in Arusha region that aimed at identifying technologies for connecting rural users are presented and discussed.

3.5.1. Connectivity

It was found that VSAT and microwave radio networks were used to connect rural users. Users very far from the reach of network centers are using VSATs and microwave radios to connect. In some parts, a 2G wireless technology is available but it does not provide a reliable broadband connectivity. Even in areas where 3G cellular technologies exist, users do not have smartphones to utilize the broadband services available to all regardless of their geographical location. Very few users use optical fibre as a last-mile solution.

3.5.2. Telecentre

In the case of telecentres, there were no telecentres found in the surveyed areas despite the fact that it was likely to have them given the telecentres initiative that was launched in Tanzania in 2001 (Mercer, 2006). Although these areas are covered by the mobile networks, the only connectivity found was a second generation (2G) network, the Enhanced Data rates

for GSM Evolution (EDGE) technology with very low data rate for use with modem and smartphones. However, due to the economic situation of the areas, very few individuals own computers or smartphones to access the Internet. On the other hand, most of these areas lack electricity to power computers and smartphones, which normally need more power than other feature phones. This calls for a community service on which issues of power and connectivity can be centrally tackled by the community. According to Wangwe (2010):

“Telecentres can facilitate distance learning and enable farmers in the rural areas to use the ICT to access knowledge, share information and acquire farming skills to enhance their crop production, thus creating a culture of information and experience-sharing within the communities.”

3.5.3. Rural and Urban-Underserved Users

Initially, about five (5) ISPs were considered in order to get users residing in rural areas. These were Habari Node Marie, Tanzania Telecommunication Company Limited (TTCL), Airtel, Lupanet and Kicheko.com. However, only one ISP, TTCL had users in rural areas. The possible reason to that could be the fact that other ISPs are more business oriented than TTCL which is developmental and operates to deliver a regulatory Universal Service Obligation (USO).

Therefore, from TTCL Arusha Branch, very few customers in the rural areas were identified, all of which were tourist hotels, banks, District HQs, colleges, government and private institutions. Although the population density in such areas is low, this does not justify lack of connectivity and hence the needed basic services such as health services, education, financial services and other social services. Table 1 presents the list of users in five districts of Arusha region along with the technologies used and the subscribed capacities.

It can be noted that districts such as Ngorongoro, Monduli and Longido have mainly one broadband user which is the District Council. The remaining population is served by a low capacity 2G GSM network with limited data connectivity as was experienced during the research. Only the GSM EDGE technology was available in some areas and in the remaining areas there was no connectivity at all.

Table 1: Link and Installed Capacity for Rural Users in Arusha, Tanzania⁴.

District	Organization	Last-Mile connectivity Technology	Link Capacity (Mbps)	Subscribed Capacity (Mbps)	Subscribed Capacity (%)	Unsubscribed Capacity (%)
Karatu	DC	B_Radio	15	0.256	2	
	HV Hotel	B_Radio	15	2	13	75
	FL Hotel	B_Radio	15	1	7	
	NMB	B_Radio	15	0.512	3	
	TRA	Fibre	100	0.512	1	
	NBC	Fibre	100	1	1	97
	NSSF	Fibre	100	1	1	
Longido	DC	B_Radio	15	0.256	2	98
Monduli	DC	VSAT (AVANT)	10	2	20	80
		VSAT (SATCOM)	2	0.256	13	87
Ngorongoro	DC	VSAT	2	0.256	13	87
Meru	DC	ADSL	2	0.256	13	87
	CRDB	Fibre	100	1	1	99
	NMB	Fibre	100	0.512	1	99
	NBC-ATM1	ADSL	2	0.256	13	87
	NBC-ATM2	ADSL	2	0.256	13	87
	MCB Bank	ADSL	2	0.128	6	94
	Ngurudoto Hotel	Fibre	100	2	2	98
	Arusha-Univ	Fibre	100	3	3	97
	St. Jude School	Fibre	100	4	4	96
	World Garden	Fibre	1000	4	0.4	94.6
	NM-AIST	Fibre	1000	50	5.0	

⁴ Data Collected by Researcher

From Table 1, it can further be noted that still some areas are being served by VSAT technology which is very limited in providing broadband services. However, while on data collection at Monduli, they were in the process to acquire Avant VSAT connectivity with 10 Mbps link capacity which is much better compared to 2 Mbps link capacity a conventional VSAT technology could offer.

Also, observable is that, the optical fibre network link capacity available at NM-AIST is a huge capacity that can be used to extend connectivity services to the wider area with minimal installation cost since the cost of bringing the fibre link up to that point is already paid for. This is already a reduced capital cost to the prospective users.

From the link capacity and subscribed capacity by the users, it was possible to calculate the extra theoretical capacity that is available and can be used to extend services elsewhere in the neighborhood.

It should be noted however that, although there is no economic reason to aim at utilizing a link to 100%, it is presumed that if demand was created, the same link of say 15 Mbps would serve more users than who have currently subscribed. Technically, underutilization is expected if overbooking is considered in which case the allocation of bandwidth may exceed what is actually available with the notion that, in practice, the subscribed capacity is sometimes idle and hence a safety margin contention ratio may be allowed based on the contracted Quality of Services (QoS).

Therefore, with such assumptions, the utilization of selected links is hereunder presented and discussed. For instance, the Longido and Karatu broadband radio links in Figs. 15 and 16, respectively, are unutilized by 75% and 98%, respectively; out of the installed 15 Mbps capacity in each case.

Figures 17, 18 and 19 show an optical fibre cable network serving the respective organizations including Ngurdoto Hotel, Arusha University and NM-AIST with an unutilized capacity of 98% of 100 Mbps, 97% of 100 Mbps and 94.6% of 1 Gbps, respectively.

The broadband radio capacity that is available in Figs. 15 and 16, respectively, for Longido and Karatu is not huge compared to that in Figs. 17, 18 and 19. However, considering the fact

that the neighborhood is without such connectivity and issues of overbooking, the same link would accommodate more users.

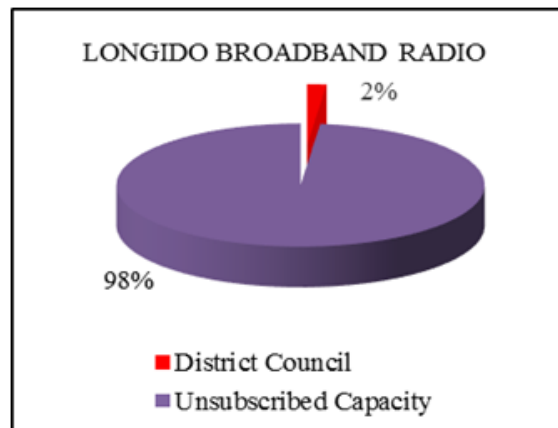

Figure 15: Bandwidth Capacity Utilization of the Longido Radio Link.

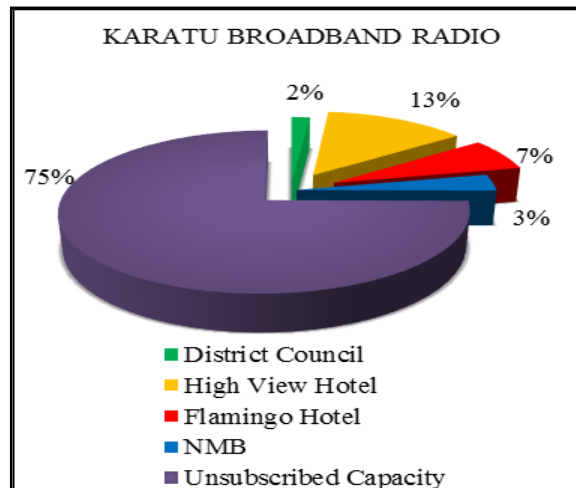

Figure 16: Bandwidth Capacity Utilization of Karatu Radio.

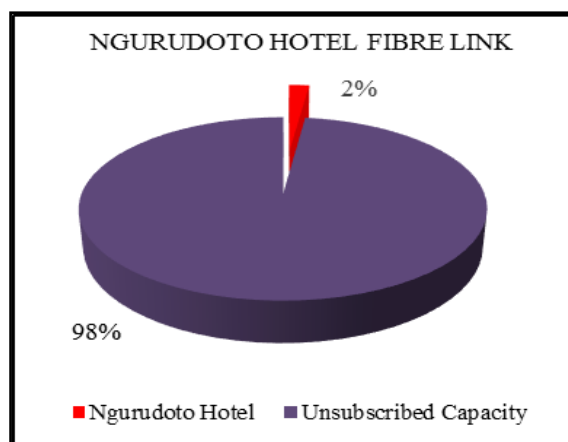

Figure 17: Bandwidth Capacity Utilization of Ngurudoto Radio Link.

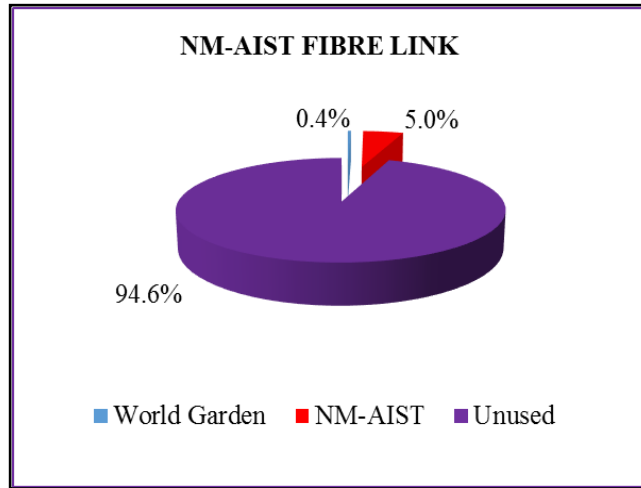

Figure 18: Bandwidth Capacity Utilization of NM-AIST Fibre Link.

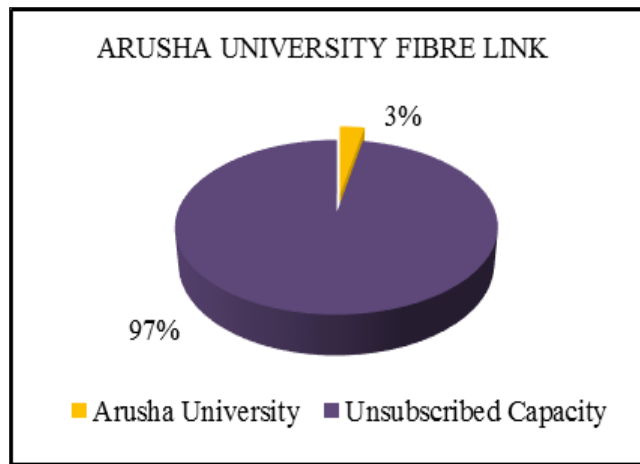

Figure 19: Bandwidth Capacity Utilization of Arusha University Link.

3.6. Conclusion

In this Chapter, the status and utilization of broadband connectivity in rural areas the case of selected rural areas in Arusha, Tanzania have been presented. In the reported utilization calculation, it is assumed that the subscribed capacity is fully used and dedicated to the respective users, which is different from reality. In this regard, the study has identified used and unused bandwidth capacity, which indicates the possibility of accommodating even more users than the stated percentages. Furthermore, the study indicates that a significant amount of broadband capacity is in the vicinity of users who are yet to be connected to the global village and be part of it.

The presented bandwidth capacity resource underutilization indicates the need for an operational advice that will guide investors in achieving universal access for all. This is achieved through a model that is presented in Chapter 4.

CHAPTER FOUR

AFFORDABLE BROADBAND CONNECTIVITY MODEL FOR RURAL AREAS⁵

Summary

Broadband connectivity is a key strategic resource for assisting change in social and economic development and wealth creation. Most of the rural areas in the developing countries inhabit more than 70% of the total population. Such areas lack basic infrastructure especially the ICTs which are required by the ITU to be universally available as a basic need of all communities around the globe, the term known as Universal Communication Access. Some countries in the developed world have achieved this goal but in most of the developing countries, there are still challenges. Although the infrastructure is available in most areas, but the utilization among communities with low purchasing power is still lacking. In this Chapter, therefore, last-mile broadband connectivity model to utilize the available connectivity in rural areas is proposed. It is in an effort to ensure that marginalized communities are connected with high data rates network at affordable tariffs. Further, six frameworks are evaluated based on network deployment cost, data rates, service coverage and accessibility to test their suitability to Tanzania rural environment.

4.1. Introduction

To bring ICTs to rural communities and elsewhere requires a reliable connectivity, which is missing in some rural areas. However, connectivity infrastructure especially in terms of mobile broadband has reached most areas, thus partly achieving the vision of ITU to provide Universal Communication Access to all. Generally, rural areas of the developing world are still largely disconnected in terms of internet and other real time services (Johnson *et al.*, 2011) despite the fact that in countries like Tanzania, more than 70% of the population live in rural areas (NBS, 2016). This is due to the fact that most rural areas are characterized by poor infrastructure and services, low income, highly scattered and low population densities (Simba *et al.*, 2011). This situation drives network operators to establish network infrastructures in urban/city centres leaving rural areas marginalized.

⁵The reference of this chapter is the extension of the conference paper available in IEEE Explore: Banyuma, M., Kalolo, S., Mrutu, S. I., Nyakyi, C., and Sam, A. (2013). Affordable broadband connectivity for rural areas. In Information Science, Computing and Telecommunications (PACT), 2013 Pan African International Conference on Telecommunications (pp. 62–65).

In the ITU call to bring Universal Communication Access to all, countries began to subsidize services provision in rural areas long since the 1990s (Dymond and Oestmann, 2002). In areas that are marginalized, it means more people residing in such areas lack ICT services and their livelihoods depend on subsistence farming, wage labor and production for sale and many works in the informal sector. Additionally, these communities often lack access to information that is vital to their lives and livelihoods, including weather reports, market prices and income-earning opportunities (United Nations, 2010) .

The contribution of ICTs to poverty reduction rest on its power to give poor people access to improved information and better communications helping them build livelihood assets. The introduction of ICTs in the enterprise sector contributes to productivity growth, innovation, economic transformation and, ultimately, improved standards of living (United Nations, 2010). Furthermore, schools found in rural and isolated areas have inadequate educational resources such as teachers, library, laboratories and other resources. However, Africa and specifically the sub-Saharan Africa lags far behind compared to other continents such as Europe, India, Malaysia and Korea (Dymond and Oestmann, 2002). Disparities between regions in terms of available internet bandwidth per internet user remain; with an average of almost 90 kbps bandwidth per user in Europe compared with 2 kbits/s per user in Africa (ITU, 2012).

In Chapter 3, it has been well documented that various efforts in Tanzania are in place, including; setting policy to require operators to reach rural areas, subsidizing the service provision through the UCSAF to deliver services to rural, remote and underserved areas, as well as shared access to CICs or telecentres and villages to ensure communications for all (Mbarawa, 2010). Another effort made by the government of Tanzania is the NICTBB project (MCST, 2012) but all these are not fully utilized to make sure each and every individual get and use the internet and associated services.

The Tanzania National Development Vision 2025 aims at achieving a well-educated and learned society by the year 2025. The achievement of this vision depends on the integration of ICT services in education through e-learning initiative. (Simba *et al.*, 2009) contend that most of such ICTs initiatives are challenged by limited or lack of connectivity to majority of secondary schools, especially those in rural and remote areas (Simba *et al.*, 2009) which are lacking educational resources such as library, laboratory and teachers.

Typical examples from our research are the Nganana and Nambala Primary schools, the Kikwe and Usa-River Secondary schools that are at a short distance from NM-AIST, where fibre connectivity terminates.

In this work therefore, it became necessary to investigate the possibility of tapping the available connectivity in the neighborhood of underserved communities to provide connectivity to schools, colleges, health centres and community organizations by using various technologies. The proposed framework will find its applications everywhere in the country and elsewhere in the globe to bring the first/middle mile at the vicinity of the low-income communities who are unable to bring the connectivity on their own. Various connectivity technologies are investigated based on capacity, installation cost, supported services and distance/coverage from the fibre optic termination and finally propose a sustainable framework that can be applied elsewhere in the country.

4.2. Literature Review

4.2.1. Viability and Sustainability

Due to the unique characterization of the rural and underserved areas, services provision depends on government or donor funding or both unlike in urban areas where investment follows demand and ability to pay for the services. In addition, it is contended that funded models drain financial resources and are neither scalable nor sustainable (Ramachander, 2007). This calls for an appropriate model to ensure viability and sustainability of such projects and non-dependence on donor funding.

It is also generally agreed that providing connectivity to rural areas is not financially viable to operators (Simba *et al.*, 2012). This situation calls for innovations that will present a rural area as a financially viable market and this is only possible through various means; one is creating demand through a policy definition of services that would really attract rural areas, those services that relate with their day to day activities such as the market price announcements for their crops and other products found in the areas, extension services for agricultural services, TV programs involving their activities, marketing forum for their products and services, online counseling services , provision of school learning materials like laboratory video clips, e-books, e-library and similar services.

4.2.2. Shared Services Models

Shared services model in the form of telecentres have been in place since in the 1990s and were meant to accelerate the telecommunication services provision in rural and underserved areas to minimize the digital divide. To date, various studies have demonstrated the importance of telecentres for access to ICTs and other services that are not accessible at individual level.

Malaysia is one of the countries that have mainstreamed ICT as a strategic driver to support and contribute to the growth of the economy and they see telecentres as a means to provide shared access in large scale to underserved groups such as the areas of low education, non-professional occupations, higher proportions of young and old, low incomes, and the rural populations (Harris *et al.*, 2007). Other countries are South Africa, India, Ghana and Malawi. Tanzania has also emphasized much on the use of telecentres for social economic development although much need to be done for mainstreaming this particular initiative in the country (Mercer, 2006; Ngowi *et al.*, 2015; TCRA/BIID/TTN, 2011). Similarly, Malawi which is a neighboring country to Tanzania have recommended a shared service model as the only viable means to connect rural areas (Chawinga and Zozie, 2016; Kapondera and Hart, 2016). These models propose shared service in the form of kiosk, telecentre or community service centres. These are various names but they all refer to having a common place where services are offered to all people residing in the area within some kilometers from the centre. Initiatives of this kind have been extensively implemented all over the world and in particular, in the developing countries. In some of these countries the associated projects have been successful while in others the implementation lasted as pilot projects only. Reasons to non-successful cases may differ from area to area and efforts to find a common solution to rural areas are sought in this study.

4.2.3. Choice of Technology

This section presents various technologies that have been extensively proposed in the literature as cost effective for rural connectivity.

i) Worldwide Interoperability for Microwave Access (WiMAX)

WiMAX wireless access technology is based on IEEE 802.16 specifications enabling the delivery of last-mile wireless broadband access. It is an air interface standard for broadband

wireless access systems using point-to-multipoint infrastructure designs, and operating at radio frequencies between 10 and 66 GHz, addressing line of sight environments (LOS) (Siebörger and Terzoli, 2010). Later development introduces non-line of sight (NLOS) WiMAX technologies including IEEE 802.16a, IEEE 802.16d, IEEE 802.16e, IEEE 802.16j and IEEE 802.16m all operating at radio frequencies between 2-11 GHz.

WiMAX targets an average bandwidth of 70 Mbps with peak rates of up to 268 Mbps. However the frequency range of 10 - 66 GHz is subject to attenuation and affected by atmospheric conditions in particular rain and trees that are typical situations in many rural areas. These limitations motivated emergence of other standards as mentioned earlier.

Each of the improved standards accommodates a given requirement or improves efficiency on a specific aspect. For example; the IEEE 802.16d is known as fixed WiMAX and IEEE 802.16e is known as mobile WiMAX (Chaudhari, 2011) which is an amendment of IEEE 802.16d by adding a Scalable-Orthogonal Frequency Division Multiple Access (S-OFDMA) and many other features on the standard for support of mobility (Rakesh and Dalal, 2010). The IEEE 802.16m aims to further improve capacity to 1 Gbps and 100 Mbps shared bandwidth and enhance both the bandwidth and mobility (Ghazisaidi *et al.*, 2009). Modulation schemes used by WiMAX include BPSK, QPSK, 16-QAM, 64-QAM and 256-QAM. These are in an order of increasing complexity and provide comparatively higher throughput (Siebörger and Terzoli, 2010).

However, currently WiMAX networks face many challenges including a decrease of data rate with increase of distance from the base station which in turn shortens the theoretical coverage range which has been addressed by the IEEE Working Group using the relay technology for data transfer (Chang *et al.*, 2012). The maximum theoretical coverage distance for WiMAX is 50 km.

ii) Fibre to the Home Framework

Fibre-To-The-Home (FTTH) provides Internet connectivity by running fibre optic cable directly from an Internet Service Provider (ISP) to a user's house or business premises, it is also known as Fibre to the Premise or building (FTTB/FTTP). It facilitates much faster speeds than dial-up and most coaxial cable Internet connections, and generally requires less maintenance as compared to other types of cables. Moreover, FTTH is considered to be one of

the prominent future internet connectivity technologies, since it offers 25 000 GHz of bandwidth in a single strand (Ghazisaidi *et al.*, 2009).

There are various ways to achieve optical fibre cable network. A combination of those different access technologies is commonly referred to as Fibre-To-The x (FTTx). FTTx includes technologies such as FTTH which is 100% optical fibre network or a hybrid of optical fibre and twisted pair or coaxial cable networks. Other examples of such networks are Fibre-To-The Node (FTTN) and Fibre To-The-Curb (FTTC). Most of these hybrid networks work by having one end of a copper cable that runs directly to a user's building while the other end of the cable connects to a Fibre optic cable that goes to the ISP, where the Internet signal originates. Sometimes, copper wiring at the last-mile runs longer distance and cause electrical signals to deteriorate (Cobo *et al.*, 2012).

Fibre Optic Access Networks such as FTTH have many merits including speed and reliability in transmitting signals in which case users can both upload and download quickly and support high quality streaming media over a long distance. Additionally, since fibre optic cable is made of glass materials that are less susceptible to weather damage and can last more than 40 years, whereas copper cabling need to be restructured every after five years. Despite its merits, Fibre Optic networks face a number of demerits: FTTH is costly and requires significant installation works which involves dig up of long trenches to bury the cable. This becomes more complex when the cable needs to run along road reserves or water bodies. Fibre optic cables are also prone to vandalism if the cable runs along a region with rural people who may think of uprooting a piece of the fibre for sale or any other use. In some areas, rodents eat fibres resulting into communication cut off.

iii) Multichannel Multipoint Distribution Service (MMDS) Framework

Multichannel Multipoint Distribution Service (MMDS) also known as Broadband Radio Service (BRS) or Wireless Cable is a point to multipoint wireless technology that uses Ultra High Frequency (UHF) for general purpose broadband networking or more commonly as an alternative method of cable television programme reception (Bates, 2002). A single tower of a network is a hub in a point to multipoint architecture that multiplexes communications from multiple users and provides coverage to a large service area at a relatively low cost to the service provider. The tower has backhaul connectivity to the carrier's network using the

optical fibre. Its suitability for sparsely populated rural areas lies on the economic and technical viability as compared to other service platforms (Rayes, 2000).

MMDS broadband technology allows faster and quicker network deployment; lowers entry, deployment and upgrade costs; lowers maintenance, management and operational expenditure enabling earlier return on investment; guarantee coverage and service expansions based on the level of demand; and provides a full suite of interactive voice, video and data services in single network architecture. Figure 20 presents the possible MMDS architecture.

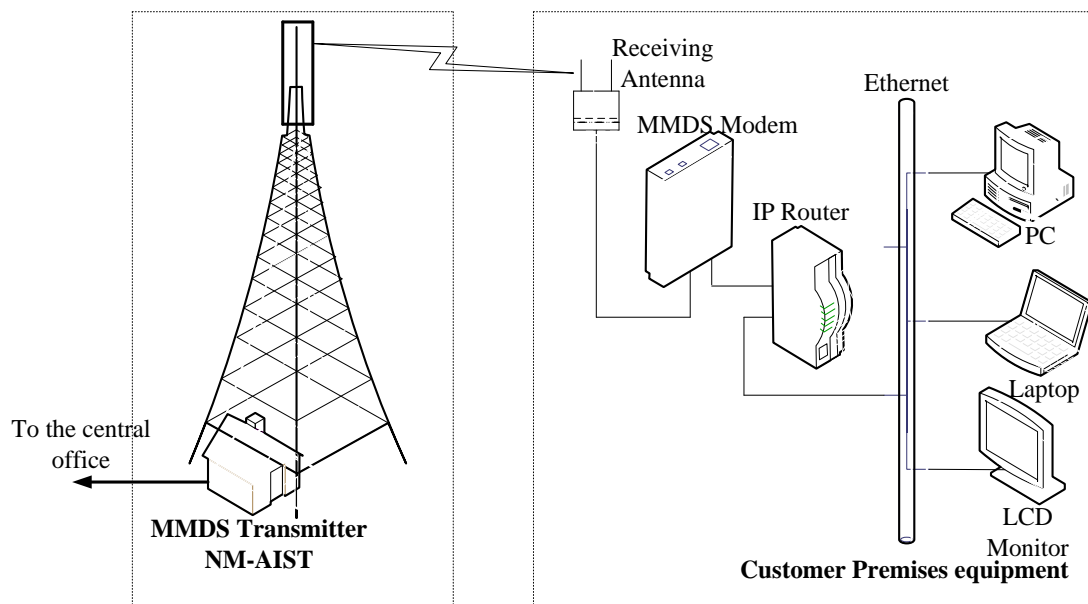

Figure 20: MMDS Architecture.

MMDS uses microwave frequency at 2.1 GHz, from 2.5 GHz to 2.686 GHz to cover a range of over 50 km radius in a line of sight transmission. Network deployment are also possible using the 2.4 GHz unlicensed band as stated above. The MMDS uses standard Data over Cable Service Interface Specification (DOCSIS) interconnected with microwave antennas that are modified to DOCSIS in a wireless broadband platform. The security of traffic flow originates from encryption applied between the wireless modem termination systems (WMTS) and the broadband wireless modem. The WMTS are found at the network provider's base station. DOCSIS+ reduce service theft vulnerabilities by enforcing encryption and authenticated client/server key management protocols.

MMDS spectrum band is divided into a 33, 6 MHz channels allowing multiplexing of several television channels, radio and internet data onto each channel using digital technology. Each

channel is capable of 30-34 Mbps when a 64-QAM modulation is used and 42-88 Mbps when a 256-QAM modulation is used. However, forward error correction and other overhead limits actual throughput to around 27 Mbps for 64-QAM and 38 Mbps for 256-QAM modulation. Sharing of radio channels among different end users reduces the average data throughput per user as compared to other broadband wireless options. In a downlink connection, the maximum throughput is about 5 Mbps with a typical throughput of 500 Kbps to 1.5 Mbps depending on other customer traffic. Network capacity is managed using narrower and more focused radio beams, additional of more radio channels, additional of more radio cells and sectoring.

iv) TVWS

Television white spaces (TVWS) refers to vacant channels in the ultra-high frequency (UHF) band between 470 and 690 MHz assigned for television broadcast and can be used opportunistically by secondary users (SUs) (Masonta *et al.*, 2015a). TVWS are recommended for use in rural areas due to associated low cost of operation and a substantial amount of bandwidth for broadband services., they can provide broadband connectivity of up to 16 Mbps (Roberts *et al.*, 2015).

Table 2: Comparisons between Broadband Technologies.

	MMDS	FTTH	WiMAX	Microwave Radio	TVWS	Wi-Fi
Coverage (Km)	>= 50 (70 miles)	up to 20	<= 50	15	10-30 & 8-12	0.1
RF Requirement	Yes- free band	No	Yes- commercial	Yes	Yes- (UHF) lower frequency	Yes- free band
Throughput (Mbps)	up to 38 (100)	up to 2488	70-268	Up to 15	Up to 16	54
Installation costs	Low	High	Moderate	Moderate	Moderate	Low
Proneness to vandalism	None	Prone	None	None	None	None
Supported Services	Video, Voice and Data	Video, Voice and Data	Video, Voice and Data	Video, Voice and Data	Video, Voice and Data	Video, Voice and Data
Frequency Fee	Yes	No	No	No	Yes	No

The possibility of using unlicensed radio frequency spectrum for MMDS and TVWS favours them over WiMAX and Microwave Radios that utilizes highly priced radio frequency spectrum. Apart from the cost involved, some services just need high bandwidth networks to successfully be offered hence the need to take up the associated costs and innovation means to get a business model that will bring profit or reward in excess of the costs and hence give some profit to an entrepreneur. Technologies such as FTTH and Microwave Radios involve huge costs especially during the investment phases, however there after remains operational costs that are manageable.

Generally, with the situation existing in the rural areas in Arusha Tanzania as reported in (Byanyuma *et al.*, 2018), these technologies are available in different areas and were found to have excess bandwidth that could be utilized by other users with minimal cost if such resource is managed well and the right regulations and policies are in place. With such assumptions the following model is proposed.

4.3. Model Definition and General Assumptions

We consider the different technologies including; MMDS, FTTH, WiMAX, TVWS, MICROWAVE RADIO and WI-FI that are available in the given areas to propose last-mile connectivity solution. To decide the appropriate technology for distribution of multimedia data, it is necessary to seek for an optimal and general interest in relation to the service deployment environment. However, technology choice will be considered where there are a number of them; otherwise the available technology will be used.

4.3.1. Model Definition

The conceptual model in Fig. 21 shows a representation of the solution to bandwidth utilization problem in rural areas where a shared model like that of the telecentre is assumed. The difference with the telecentre model lies in the mode of operation (ownership), funding and services differentiation to include brokerage services such as a broker working on behalf of the users, for instance, the broker can set up websites, blogs and other networks and manage them on behalf of users in a cause of selling and buying through ICTs at a fee obtainable in the same services. This is necessary for users who are illiterate but have innovations and products and services that need to be marketed worldwide.

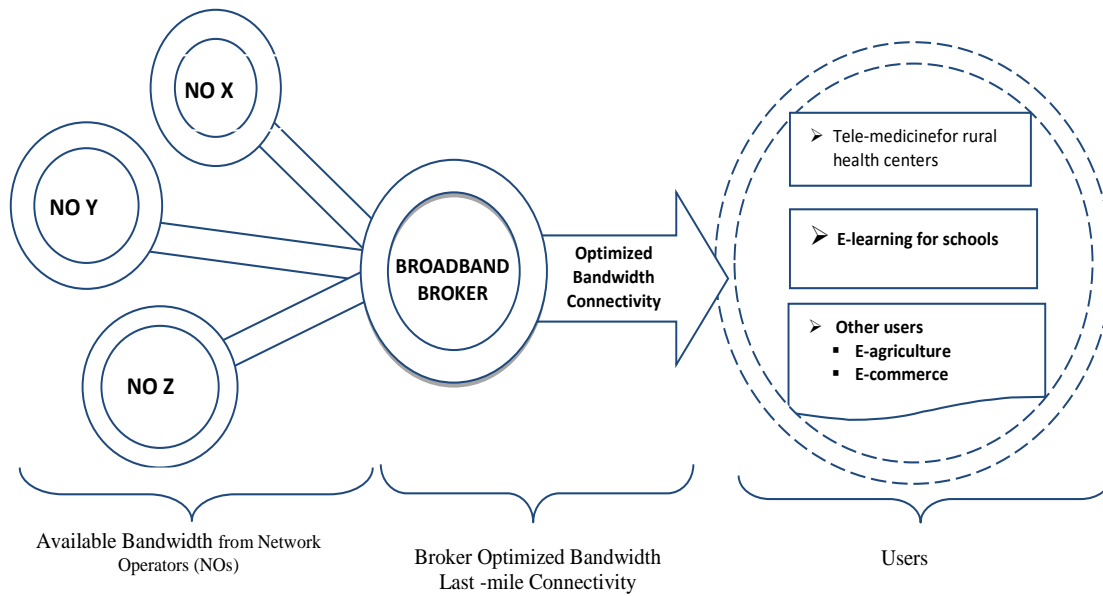

Figure 21: Conceptual Framework for Broadband Shared Services Broker Model for rural areas.

NO X, Y and Z are the network operators available at the given area and these could have different technologies with different capacity for which a customer (broker) is connected and subscribes to the bandwidth capacities (C1, C2, C3). The broker is the one who will pay for the bandwidth capacity from NOs and sell the same to users on the right side of the diagram. In order to make profit, the broker needs to manage these three input capacities so as to provide a reliable broadband service to users while getting a reward or profit.

The scenario depicted in Fig. 21 implies that, the users need not know the technology serving them, but they know the quality of service they pay for. Therefore, a very important issue here is how to manage the bandwidth to provide to users with their respective priority and QoS. Two priorities are assumed, where by each service request will belong in either a priority group High (H) or Low (L). Each service request will represent a given priority class and QoS. For instance, user with High priority may request resources for an email service and this has a minimum level set QoS accessible from the available operator (X, Y or Z) network bandwidth. A system must be able to allocate resource accordingly based on user priority level, requested service, QoS for that particular service and the best network at that particular moment. Table 3 and the key that follow it presents the scenarios that can be coded to manage the priority and service quality for the users.

Table 3: Priority and Service Differentiation for the Rural Broadband Service Broker.

User Priority	Services	Service Priority	QoS Required	Service Tag
High	Teleconferencing (TC)	P-TC	Q1	HP-TC-Q1
	Video streaming (VS)	P-VS	Q2	HP-VS-Q2
	Interactive Voice (IV)	P-IV	Q3	HP_IV-Q3
	Email/web (EW)	P-EW	Q4	HP-EW-Q4
Low	Teleconferencing (TC)	P-TC	Q1	LP-TC-Q1
	Video streaming (VS)	P-VS	Q2	LP-VS-Q2
	Interactive Voice (IV)	P-IV	Q3	LP_IV-Q3
	Email/web (EW)	P-EW	Q4	LP-EW-Q4

KEY:

Priorities:

- P-TC Priority for Teleconferencing service
- P-VS Priority for Video streaming service
- P-IV Priority for Interactive voice service
- P-EW Priority for Email and web browsing

Quality of Service

- Q_i (i=1-n) Quality of Service level for a give service

Service tag for given priority, service type and QoS level

- HP-TC-Q1 High Priority, Video streaming service, QoS level 1
- HP-VS-Q2 High Priority, Teleconferencing service, QoS level 2
- HP-IV-Q3 High Priority, Interactive voice service, QoS level 3
- HP-EW-Q4 High Priority, Email and web browsing, QoS level 4
- LP-TC-Q1 Low Priority, Video streaming service, QoS level 1
- LP-VS-Q2 Low Priority, Teleconferencing service, QoS level 2
- LP_IV-Q3 Low Priority, Interactive voice service, QoS level 3
- LP-EW-Q4 Low Priority, Email and web browsing service, QoS level 4

The service tag in the presented framework helps in the identification of the service type, its QoS level and the user priority.

4.3.2. Model Assumptions

The following assumptions are considered:

- i) A high demand for broadband services in the neighborhood of a rural or urban-underserved area follows the presence of other institutions, schools and other non-governmental organizations.
- ii) Availability of subsidization mechanism for rural and isolated areas and availability of radio frequency spectrum.
- iii) A notion that a shared service will attract agricultural and other sectors to visit the centre on daily basis
- iv) No electricity to charge mobile phones for the users so availability of affordable smart phones do not guarantee usage of the same by individuals. And also, mobile phones in particular, smartphones are expensive and need reliable electric power that is not found in those areas.
- v) The centre services will be a close alternative to owning their own mobile phones
- vi) The centres will be solar powered with a possibility of upgrading to electrical power
- vii) Cost per usage will depend on the service required by a customer whether High or Low Priority
- viii) Other specialized services will be offered at the centre to boost the profit for service sustainability.

4.4. Conclusion

The technology independent framework for broadband connectivity in rural areas has been presented. The framework can tap the potential of optical fibre backhaul bandwidth and other networks terminated in every district in the United Republic of Tanzania. This framework reduces capital expenditure (CAPEX) and operational expenditure (OPEX) costs while delivering high speed broadband connectivity, video and telephone services to end users. The reduction in CAPEX costs is achieved through the utilization of the backhaul network that is already in place. Furthermore, significant benefits of the proposed last-mile broadband connectivity depend on proper utilization of the available bandwidth. The detailed analysis of the economic feasibility of the model is a focus of future works.

The model that has been proposed in this Chapter can be achieved through management of priority and service quality for the users and through the optimization of the bandwidth resource usage as presented in Chapter 5.

CHAPTER FIVE

A MODEL FOR OPTIMIZATION OF BANDWIDTH UTILIZATION IN RURAL AND URBAN-UNDERSERVED AREAS USING QUEUING ANALYSIS

Summary

From the previous chapters, it is argued that while advancement in technology and the emergency of cellular mobile technologies have brought the broadband services close to the communities such that even the remotest areas can be reached. However, the problem that remains as discussed in Chapter 1, 2 and 3 and need further investigation and solution is the utilization of such resources. One of the solution to this problem is the RBSB model that has been proposed in Chapter 4 that adopts a shared service model that allows one main user (called a broker in this study), to subscribe and share the service with other users at a price.

In this Chapter, a model to utilize the subscribed bandwidth is sought so as to achieve sustainable broadband services provision that will benefit the rural provider (broker) while achieving the quality of services to users. A shared service model is considered and is defined in this case as a rural broadband service broker (RBSB) model due to its added brokerage related services. The study applies the M/D/1 queuing model to opportunistically share the subscribed bandwidth between the licensed or primary user (PU) who owns or pays for dedicated broadband link to dimension the unused chunks of bandwidth capacity to unlicensed or secondary users (SUs) with low priority. This model is strategically demonstrated by selecting locations of RBSBs to deliver optimal broadband bandwidth at a reasonable reward, hence solve the sustainability issues. The study adopts the techniques used in cognitive radio networks for optimal dimensioning of bandwidth to utilize it fully.

5.1. Introduction

In the past decade, governments and nongovernmental institutions have invested widely in connecting rural users with ICTs through various initiatives as a move to diminish the digital divide, which is the gap between those with and those without ICTs. It is widely acknowledged that there exist substantial digital divide between countries and regions, and between developed and developing countries, particularly the Least Developing Countries (LDCs). It is further reported that there are twice as many mobile-broadband subscriptions per 100 inhabitants in developed countries compared to developing countries, while the gap

between more-connected developing countries and LDCs has grown in recent years (ITU, 2017a).

The universal service access initiative is one of the ITU's initiatives that aim at ensuring equal basic access to all regardless of their geographical situation. This initiative requires governments worldwide to facilitate the creation and implementation of universal access service fund that would subsidize operators to invest in unattractive rural areas. Governments have different goals on what to include in their universal access plans; for instance, the current universal access plan in Tanzania includes only universal access to voice services by extending mobile cellular 2G network coverage in rural and urban-underserved areas. However, an increasing number of governments have included access to broadband in their universal access plans (ITU, 2013). The universal access plans have either subsidized services in uncovered areas or employed the private public partnership (PPP) programs to achieve the same. Both subsidization and PPP programs bring services closer to users but users still need to pay for such services to sustain these investments.

Utilizing and paying for services depend on various aspects including; purchasing power, knowledge of services, demand for services and economic aspects of provided services. Lack of any of these aspects plays a role on the problem of sustainability of the PPP or the universal service access projects. Therefore, utilization of available or subsidized services is very important (Byanyuma *et al.*, 2018). On one hand, the cost of broadband services involves among others, bandwidth cost which has been lowered over the years due to the emergency of the high capacity fibre and submarine cables all over the world connecting users worldwide. On the other hand, due to the emergency of smart devices and other bandwidth hungry applications running on smart devices, the required bandwidth is high and this is at an additional cost. Since this will be increasing with time, users need to be able to pay for that. In addition, the demand for bandwidth is increasing and that implies increased cost. Therefore, the increasing bandwidth usage needs an optimized bandwidth model for efficient utilization.

In the case of rural telecommunications, it has been continually documented that there exists a digital divide especially in rural areas due to its nature of unattractiveness for investment. This is caused by associated geographical location with poor infrastructure in terms of roads, electrical power, health and other social services. Despite these, rural areas inhabit a big percentage of population and are where agriculture, mining and other economic activities are

found. Due to this, all basic services such as education, health, financial and social services are needed just as much.

While the geographical nature may still be cumbersome for physical reach, wireless technologies make it possible for almost all services to be available through broadband connectivity services. However, due to different financial/purchasing power (Sumbwanyambe *et al.*, 2011), there still exist disparities in provision of broadband services among developed, developing and least developing countries (ITU, 2012).

Although many efforts in Tanzania are in place to bring broadband services to all, most citizens still cannot access broadband services (URT, 2016). Reasons for not using the services are mentioned as (Byanyuma *et al.*, 2018):

- i) Affordability of smart devices and associated charges,
- ii) Limited capacity and reach of the mobile broadband network,
- iii) Low literacy rate and lack of knowledge, and
- iv) Lack of basic infrastructure such as power and roads.

In this particular study, Byanyuma *et al.* (2018) argue that the factors mentioned above result in low broadband service usage and hence low utilization of the bandwidth resource that the countries such as Tanzania has so far invested in. Although the regulatory framework regarding how such unsubscribed capacity can be exploited is not in place, this study proposes a model for consideration as a way to address the persistent low broadband service penetration in those areas.

In this Chapter, a model through which utilization of available broadband connectivity can be achieved to bring improvement in the socio-economic development is developed. It presents the model with associated assumptions and the key motivations. It applies the cognitive radio techniques to model a service centre that will provide broadband services to bandwidth hungry applications and other general purposed applications and demonstrates how an entrepreneur would run a centre at a profit while utilizing the bandwidth optimally. In this case, a modified M/D/1 model is used to dimension bandwidth resource so that SUs are served when the PU is not using the service.

5.2. Related Work

Studies on opportunistic spectrum access in cognitive radio networks focus on how the unlicensed or SUs opportunistically access free spectrum to transmit their packets. For example, the opportunistic access of PU in a cognitive radio network in bounds using analytical M/D/1 queuing model using the primary packet waiting time is analyzed in Kwesigabo *et al.* (2017) where the secondary packet arrival time, which maximizes single channel utilization using utility function is determined. The number of packets admitted on the system and their waiting time is calculated using M/D/1 model in which the spectrum owner gets reward on each successful transmitted packet.

Earlier on, a similar study by Suliman and Lehtomaki (2009) analyzed opportunistic spectrum access in cognitive radio in which a PU has priority over SU. A system with time slots was considered where the SU performs spectrum sensing at the beginning of each slot to know if it is occupied by a PU or not. Suliman and Lehtomaki_(2009) performed theoretical analysis using M/D/1 priority queuing scheme and validated their model by using simulation scheme whose results demonstrate a high degree of accuracy for their derived expressions. Their results indicate that, the performance of the SU depends on the data traffic characteristics of PUs.

SUs may cause interference when they receive more packets which are organized on their own queues. To address this, a scheduler implementation is proposed in Lakhali and Idrissi (2014), which can cause channel competition when there is SU in a system waiting for a channel to be released to transmit their packets. The scheduler manages a queue and assigns a free channel to SU. Lakhali and Idrissi (2014) use mono-scheduler to assign the free channel to SU to manage queues and ensure an equity value between transfer rates using Jain Fairness Index (JFI) as a metric. The mono-scheduler algorithm results had significant equity between groups, and results between SUs were relatively low. However, they got better results when they considered each user as a group.

Although SU traffic is treated as non-priority in the cognitive radio network analysis, there is latency-sensitive traffic of secondary connection through the life time of secondary connections performance metrics. This is addressed through the Preemptive Resume Priority (PRP) M/G/1 queuing model which uses the extended data delivery time metric to analyze leaving or staying spectrum handoff sequence (Ndiomo *et al.*, 2013). Ndiomo *et al.* (2013)

found extended data delivery time to be reasonable but with limited metrics due to lack of prevision, which is the quality needed in cognitive radio network using spectrum handoff sequences.

A study by Wang *et al.* (2011) propose an analytical framework integrated with PRP M/G/1 queuing model system to design system parameters for sensing and the probability based spectrum decision schemes. The framework evaluates the effect of multiple interruptions, sensing, errors and channel capacity on the overall system time compared to the sensing based scheme for light secondary traffic loads where the sensing based scheme performs better in the condition of heavy traffic loads. A similar study by Huang *et al.* (2014) use the M/G/1 queuing model in combination with information theory to analyze spectrum sharing by deriving the average delay time of secondary packets. They derive spectrum allocation by considering transmission delay and throughput function to make full use of spectrum holes which are detected by SU. The average transmission delay of each packet is determined with the analysis of each virtual queue, and then a spectrum hole is allocated for each packet in the whole system (Huang *et al.*, 2014).

Furthermore, Filippini *et al.* (2013) propose an analytical framework by combining the queuing and game theories to access performance of spectrum sharing process. Queuing theory was used to model the achievable throughput of SU and game theory was used to capture competitive dynamics of spectrum sharing process among multiple SUs. The proposed framework was used to derive performance measures of spectrum sharing when spectrum access is either regulated or not by central spectrum management authority.

The cited researches establish and demonstrate the capability of M/G/1, M/D/1 queuing and other techniques on opportunistic access of unutilized portion of the primary resource to achieve various parametric performances. For instance, Suliman and Lehtomaki (2009) establish that the arrival rate of SU is higher than the average waiting and average queuing length of SU growth especially when the combined arrival rates approach the queue utilization factor. Various performance parameters such as the possibility of interference to the primary user (Lakhali and Idrissi, 2014), the achievable throughput for the SU (Filippini *et al.*, 2013) and average delay (Huang *et al.*, 2014) are also measured. Additionally, the analysis of optimal SU arrival rate with respect to the reward and operational cost, service rates and PU arrival rate is studied in (Kwesigabo *et al.*, 2017). The latter is adopted for the efficient access to bandwidth by utilizing a portion of time that is not used by the primary

user (PU). The following sections define the model through which the optimal bandwidth utilization is achieved. We apply the same queuing techniques to ensure the bandwidth subscribed in rural areas is optimally utilized and gives a reward to the service provider who in this case is a Rural Broadband Service Broker (RBSB).

5.3. The Rural Broadband Service Broker (RBSB) Model

As mentioned in Chapter 4, in order to study the bandwidth utilization of a typical rural network, a resource sharing mechanism was adopted, where by the subscribed capacity is shared among the service centre users. The first consideration towards the effective use of the bandwidth resource is the need to identify the types of services to be offered and then estimate the amount of traffic to be generated. Starting with service types, it is expected that most of the services at the centre are those that really would require users to demand services at a cost. Since most of these areas are covered by a 2G cellular network, we assume that voice service will not be a reason for one to visit a centre. However, due to increased demand for e-health care and e-learning we expect the centre to be able to provide streaming video, telemedicine and e-learning services. Of these services, each has its QoS, which involves prioritization of network traffic and can be targeted at a network interface, toward a given server or router's performance, or in terms of specific applications. A network monitoring system must typically be deployed as part of QoS, to ensure that the network is performing at the desired level.

The model adopted in this study is motivated by the need to share resources in rural areas where purchasing power is very low while demand for quality broadband services is high. The high demand is due to the fact that, rural areas, being disconnected from urban centres and from various basic services such as health, education, financial, social and other services, their only hope is to utilize broadband technologies to wirelessly reach the difficult to reach areas by physical means through ICTs. Additionally, it is in those areas we find raw materials, minerals tourist attractions, arable land for agriculture and other resources that can be exploited advantageously through ICTs enabled by broadband connectivity. The next sections present the model.

5.3.1. The RBSB Conceptual Bandwidth Model

In the analysis, three cases are assumed at the selected area for research, whereby a broadband service center could be situated at either a school or college, health centre or at the

business centre where there is a substantial inflow of people. Then, each centre is treated as a separate service centre whose main user is either a school, or a health centre or a business centre depending on where it is situated. At each of these centres there will be a main user called a PU and other users as SUs as in Lakhali and Idrissi (2014), termed in Chapter 4 as High and Low level users respectively.

Figure 22 shows the RBSB model representing only one of the PUs as indicated on Fig. 21 in Chapter 4.

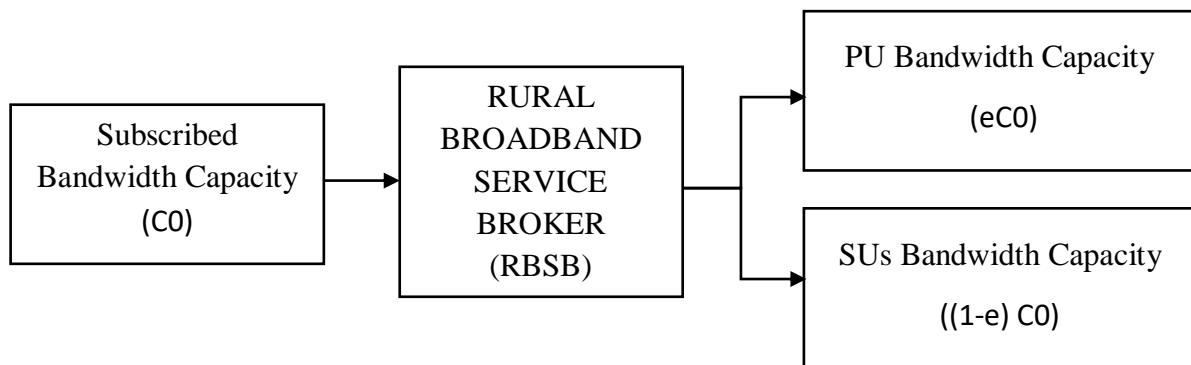

Figure 22: The Conceptual Rural Broadband Service Model showing the Subscribed Bandwidth and the Shared Bandwidth to PU and SUs respectively.

At any given time there will be capacity C_0 from either network to be allocated to PU and SUs, respectively. The SUs can be connected using WI-FI hotspots and when they request for a service, their priority being low, the system will check if the high priority PU is not using the service and will be queued or put through accordingly as detailed in the next sections.

5.3.2. The M/D/1 Model

The RBSB model adopts the M/D/1 queuing model in which, service time is deterministic and uses exactly one slot regardless of user priority (Suliman and Lehtomaki, 2009). The M/D/1 queuing model diagram in Fig. 23 and the notations as presented in Suliman and Lehtomaki (2009) are shown in the following sections. At the input side there are packet arrivals for primary and SU respectively using one channel. The details of how the channel is shared are given in the following sections.

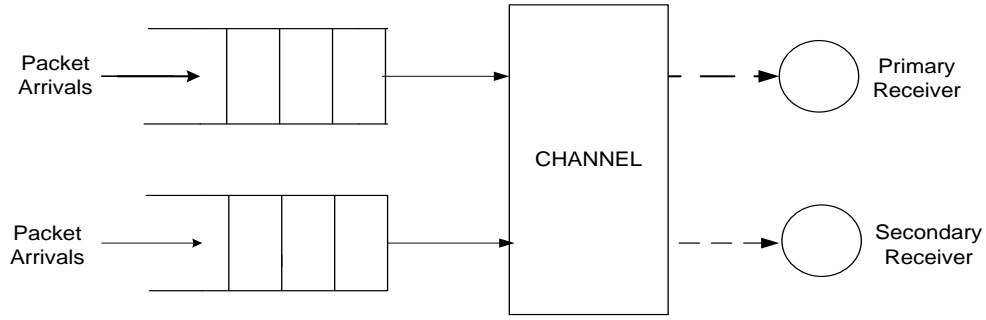

Figure 23: A cognitive wireless network diagram showing PU and SUs (Suliman and Lehtomaki, 2009).

Notations (Suliman and Lehtomaki, 2009)

λ_p	PU arrival rate.	W_s	Total time spent by SU in the system
λ_s	SUs arrival rate.	T_D	Waiting time till the beginning of a new slot
μ	Service rate.	α	Reward collected on successful priority SUs Transmission
N_q^P	Average number of packets in the priority queue of PU.	β	Priority Operational cost
N_q^S	Average SU packet in the queue.	λ_*	Available optimal spectrum size
W_q^P	Waiting time in priority queue for PU.	λ_*^D	Optimal Spectrum size demanded
W_q^S	Waiting time in priority queue for SUs.	$\rho^P = \frac{\lambda_p}{\mu}$	PU utilization factor
w_p	Total time spent by the PU in the system	$\rho^S = \frac{\lambda_s}{\mu}$	SUs utilization factor
		$\bar{X} = E[X] = \frac{1}{\mu}$	Average service time

5.3.3. Priority Queuing Model

This section considers the model as suggested opportunistically by Kwesigabo *et al.* (2017) and opportunistic spectrum access in which the SU accesses the channel. The SU senses the state of channel at the beginning of the slot and transmits a packet when the channel is idle. When the SU senses the presence of a PU, the SU packet is removed from the channel, the PU packet does not immediately join the channel after the SU packet is removed but it waits half of the slot duration even if the channel is free until at the beginning of the next slot (Suliman and Lehtomaki, 2009). The PU’s and SU’s waiting times include the time they spend in queue before joining the slot.

For perfect sensing there is no packet delay as there is no interruption between packets and once a packet is admitted it is transmitted directly to destination. Imperfect sensing and false alarm extends the packet delivery time as it can wrongly sense a free channel while in reality

the channel is busy and when a transmission occurs it causes collision with PU, or the false alarm extends SU packet delivery by indicating that the channel is busy while it is free.

The spectrum allocation is based in a First In First Out (FIFO) scheduling mechanism; a PU is given higher transmission priority. Time spent for perfect sensing by the packet in the system is defined using M/D/1 priority queuing scheme, in which packets are transmitted according to Poisson distribution process and service time is deterministic. The channel is divided into equal size slots. The admitted packet occupies one slot, SU senses a free slot at the beginning of the channel and starts transmission if the slot is free. Otherwise SUs continue waiting in a buffer until some of the slots become free. In priority queuing, when an admitted PU finds all channels are occupied by another PU, then the admitted packet drops.

Primary packet waiting time for M/D/1 priority queuing has three components: sensing delay or time until the beginning of the next slot, which is $\frac{1}{2}$ of average service time, time spent in a queue waiting for the service to begin, followed by the average service time (transmission time). Secondary packet waiting time in a queue includes the time of PU in the system and subsequent PU interaction.

The following assumptions are considered:

- i) The arrival of the packets follows the poisson process where arrival occurs at the rate λ
- ii) The service rate is deterministic (constant) for all arrivals (PUs and SUs), the channel is divided into fixed time slots of equal size, in which when a packet arrives it occupies one slot.
- iii) The system is assumed to have an infinite buffer size.
- iv) Admitted packets are patient (no balking, reneging or jockeying), once a packet is satisfied with spectrum price, it joins the queue and it waits until it gets served.
- v) Perfect sensing considered, secondary transmission has the capability of sensing the primary traffic.
- vi) No sensing error and false alarm detection.
- vii) Single channel queuing system.
- viii) Packets are admitted on channel according to Poisson distribution with mean arrival rate λ .
- ix) The system has deterministic service rate μ

- x) Queuing discipline rule uses first come first served depending on priority of the packet.
- xi) Optimal number of SUs is calculated analytically based on M/D/1 model as follows with the assumption that the service time for PU and SU are the same i.e.

$$\mu_p = \mu_s = \mu$$

5.3.4. PU Average Packet Delay

Response time is total time a packet spends in the system. In this section, the expressions for mean response time of primary user's packet when it is not delayed are derived. Tagged packet that belongs to a PU is considered. Its mean response time is delayed by the PU's packet that it finds in the scheduler's primary queue upon its arrival. The average delay of the tagged PU's packet in queue is given as:-

$$W_q^P = T_d + \frac{1}{\mu} N_q^P \quad (5.1)$$

From Little's formula, $N_q^P = \lambda_p W_q^P$, μ is the service time and T_d is time until the beginning of the next slot. Equivalently therefore, Eqn (5.1) becomes:

$$W_q^P = T_d + \frac{1}{\mu} \lambda_p W_q^P = T_d + \rho_p W_q^P \quad (5.2)$$

$$W_q^P = \frac{T_d}{1 - \rho_p} \quad (5.3)$$

Where;

$$\rho_p = \frac{\lambda_p}{\mu} \text{ - the primary utilization factor}$$

Waiting time for new admitted SU includes PU time and SU waiting time in the channel and subsequent PU pre-empted the SU.

5.3.5. SU Average Packet Delay

Newly arrived secondary packet waiting time depends on primary and secondary packets found in a queue on their arrival and subsequent arrivals at primary queue. Therefore, the

primary, secondary packet and subsequent arrivals at PU queue is included in the delay used in computation of W_q^s .

$$W_q^s = T_d + \frac{1}{\mu} N_q^p + \frac{1}{\mu} N_q^s + \frac{1}{\mu} \lambda_p W_q^s \quad (5.4)$$

By using Little's theorem on N_q^s and N_q^p , we obtain the expression for the mean waiting time of the packet in queue as,

$$W_q^s = T_d + \frac{1}{\mu} \lambda_p W_q^p + \frac{1}{\mu} \lambda_s W_q^s + \frac{1}{\mu} \lambda_p W_q^s = T_d + \rho_p W_q^p + \rho_s W_q^s + \rho_p W_q^s \quad (5.5)$$

$$W_q^s = \frac{T_d}{(1 - \rho_p)(1 - \rho_p - \rho_s)} \quad (5.6)$$

The total packet delay/time spent in the system is the time spent in queue and average service time of the packet.

Average packet delay for PU (time spent in the system) is given by the sum of the mean waiting time in the queue and the average service time of the packet. The packet's mean response time for the PU can be expressed as shown in equation (5.7).

$$W_p = E[X_p] + W_q^p = E[X_p] + \frac{T_d}{1 - \rho_p} \quad (5.7)$$

Total average delay for the SU depends on the SU average service time and SUs packet waiting in a queue and is given in equation (5.8).

$$W_s = E[X_s] + W_q^s = E[X_s] + \frac{T_d}{(1 - \rho_p)(1 - \rho_p - \rho_s)} = \left[E[X_s] + \frac{\mu^2 T_d}{(\mu - \lambda_p)(\mu - \lambda_p - \lambda_s)} \right] \quad (5.8)$$

In order to calculate the expected number of packets of the SU in M/D/1 priority queuing, the Little's formula is applied which states that, the time-average or expected time-stationary number of customers in a system is equal to the product of the arrival rate and the customer-average or expected customer-stationary time each customer spends in the system (Whitt, 1991). This gives the expected number of SU packets in the system as:

$$N_s = \lambda_s W_s = \lambda_s \left(\bar{X} + \frac{T_D}{(1-\rho_p)(1-\rho_s-\rho_p)} \right) \quad (5.9)$$

5.3.6. Optimal Number of SU Packets

Reward is obtained from each successful SU transmission. Successful secondary transmission time depends on three factors, which are: secondary packet arrival time, the number of packets both primary and secondary waiting in the system for transmission, and the time each secondary packet spends in the queue waiting for availability of free channel. By using a utility function, an optimum secondary arrival and, the opportunistic lower and upper bounds for PUs are determined. The optimum number of secondary packets are derived for a given α and β . In this section, the Profit (P) of the primary packet is used to derive the optimum number of SUs on the channel. The profit of the spectrum owner on successful secondary packet transmission is given by the total revenue minus the operational cost as shown in equation (5.10).

$$P = \alpha N_s - \beta W_s = W_s (\lambda_s \alpha - \beta) \text{ Where: } N_s = \lambda_s W_s \quad (5.10)$$

Where;

αN_s , is the total reward on each successful secondary transmission. βW_s is the total operational cost of waiting in the system.

In order to obtain a profit function, the SU packets waiting time (W_s) from equation (5.8) is substituted in equation (5.10) as shown in equation (5.11).

$$P = \left[E[X_s] + \frac{\mu^2 T_D}{(\mu - \lambda_p)(\mu - \lambda_p - \lambda_s)} \right] (\lambda_s \alpha - \beta) \quad (5.11)$$

The detailed analysis for the optimum number of SU packets arrival is obtained by applying by parts the equation (5.11) with respect to λ_s as shown in Appendix 1. This gives the optimum SU packets arrival as given in equation (5.12).

$$\lambda_s^* = (\mu - \lambda_p) + \mu \sqrt{T_D \left(\frac{\beta}{(\mu - \lambda_p) \alpha} - 1 \right)} \quad (5.12)$$

From equation (5.12), values for μ , α and β can be set as constant and allow only λ_p to vary. This will give the bounds for λ_p as in equation (5.13) and (5.14).

The upper bound for λ_p satisfies the condition in equation (5.13) while the lower bound for λ_p satisfies the condition in equation (5.14).

$$\mu - \lambda_p > 0 \therefore \lambda_p < \mu \quad (5.13)$$

$$\frac{\beta}{(\mu - \lambda_p)\alpha} - 1 > 0 \therefore \mu - \frac{\beta}{\alpha} < \lambda_p \quad (5.14)$$

The stability regions for PU packet arrivals for a given μ , β and α obtained from equation (5.15) by considering lower values of λ_p .

$$\mu - \frac{\beta}{\alpha} < \lambda_p < \mu \quad (5.15)$$

The stability region for α given μ , β and λ_p is obtained from equation (5.16).

$$0 \leq \alpha \leq \frac{\beta}{(\mu - \lambda_p)} \quad (5.16)$$

The stability region for β given μ , α and λ_p is obtained from equation (5.17).

$$\alpha(\mu - \lambda_p) \leq \beta \quad (5.17)$$

The stability region for μ given β , α and λ_p is obtained from equation (5.18).

$$\mu < \lambda_p + \frac{\beta}{\alpha} \quad (5.18)$$

The equations (5.13) through (5.18) guide the range of values to be used in the modeling and simulation in section 5.4.

5.4. MATLAB Simulation Results and Discussion

The analytical modeling in section 5.3 is simulated in MATLAB to test the effect of increasing PU packets arrival, the reward α , operational cost β , and the service rate μ , with respect to the optimal SU packet arrivals.

5.4.1. The Effect of Increasing the PU Packets Arrival on Optimal SU Packets Arrival

Figure 24 presents priority queuing with effect on primary arrivals at given service rate, spectrum price and operational cost. When the PU packets arrivals are low approaching to the lower bound, the optimal SU packets arrival slightly increases. When the PU packets arrival approaches the upper bound, the optimal SU packets steep increase. Also, when PU packets arrival decreases, the optimal SU packets arrival decreases. From this observation we conclude that in priority queuing PU packets arrival causes exponential increase to optimal secondary packets arrival at a given service rate, bandwidth price and operational cost.

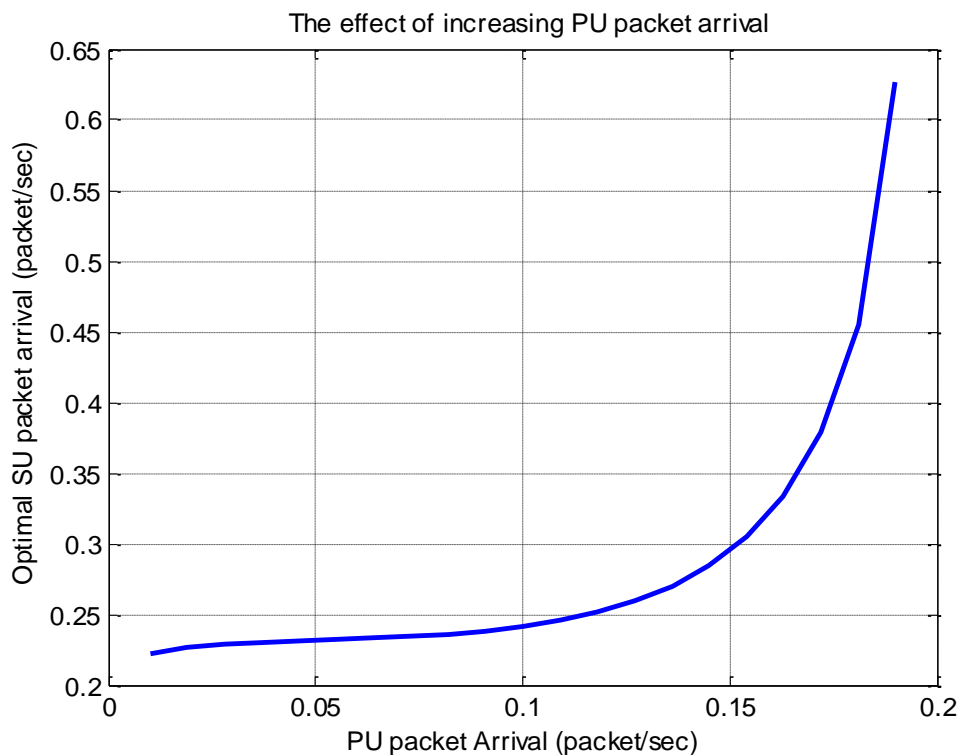

Figure 24: The effect of increasing PU packets arrival on optimal SU packets arrival

5.4.2. The Effect of Increasing Reward A on Optimal SU Arrivals

Figure 25 shows the effect of reward α on SU arrivals λ_s^* . For a given operational cost, service rate and primary arrival, the maximum spectrum price is determined from primary

arrival(λ_p) lower bound in which $\mu - \frac{\beta}{\alpha} \leq \lambda_p$, from this bound we get maximum spectrum price as $\alpha \leq \frac{\beta}{(\mu - \lambda_p)}$, when spectrum reward increases, it causes exponential decrease of optimal secondary arrival.

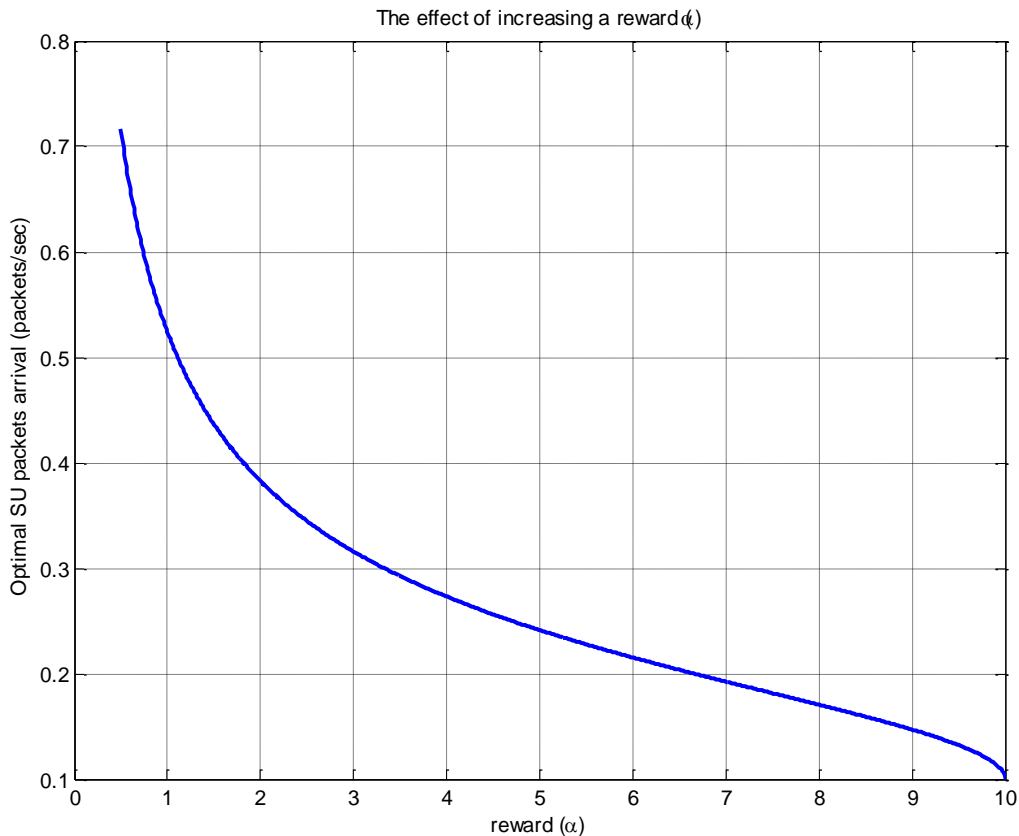

Figure 25: The effect of increasing a reward α on optimal SU packets arrival in packet/sec

5.4.3. Effect of Operational Cost B on Optimal SU Packets Arrival

The operational cost priority queuing is related to price as it is calculated from λ_p lower bound as $\mu - \frac{\beta}{\alpha} \leq \lambda_p \Rightarrow \beta \geq \alpha(\mu - \lambda_p)$. The difference between bandwidth price and operational cost is set according to service rate, primary arrivals and operational cost, while in operational cost, the service owner sets the minimum operational cost as $\beta \geq \alpha(\mu - \lambda_p)$.

Figure 26 shows the relationship between the optimal SU arrivals λ_s with respect to the operational cost β .

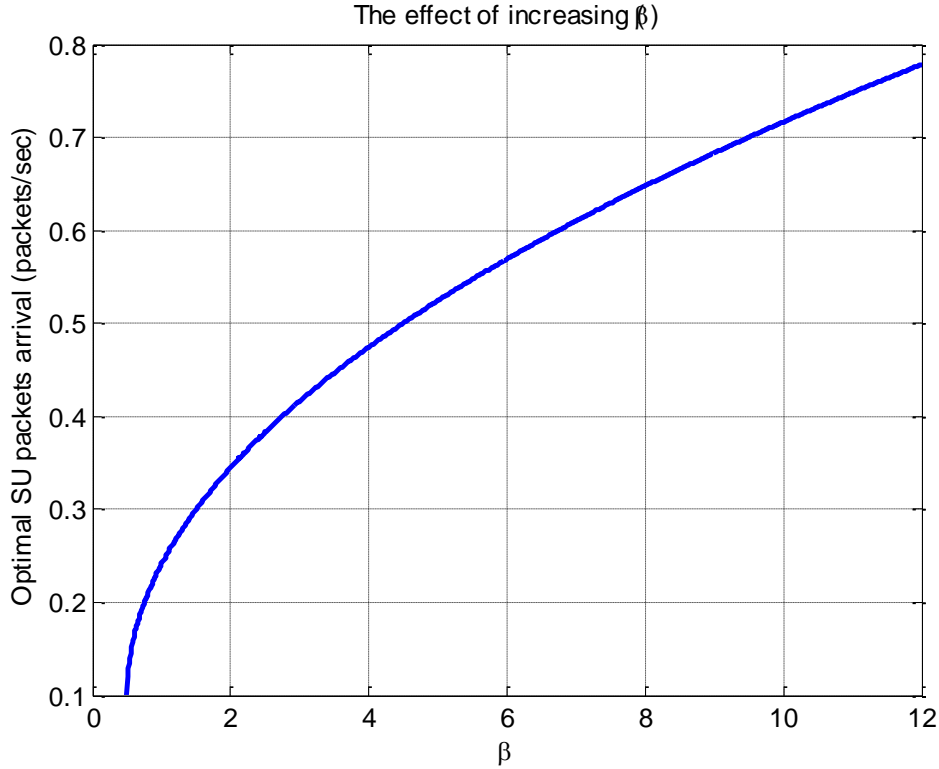

Figure 26: The effect of increasing the operational cost β on optimal SU packets arrival in packets/sec.

The minimum operational cost changes depending on parameters given. For example, when the number of primary packets arrived (λ_p) are few, the idle packet slots available for sharing are high and these enable high optimal secondary packets to be admitted. To maintain quality of arrived optimal secondary packets, operational cost increases. But when the number of primary packets arrived (λ_p) are high, almost all slots available become occupied by PU, that is, the idle packet slots available for sharing with optimal secondary arrived packets becomes low which in turn lowers the operational cost. Example, when $\lambda_p = 0$, it means there are no primary packets in the channel and all the packet slots are idle to be shared with secondary packets which in this case, a minimum operational cost is given as $\beta \geq \mu\alpha$. However, when $\lambda_p = \mu$, it means there is no free packet slots for sharing with SU, as all available slots are occupied by the PU and in this case $\beta \geq 0$. When there is no secondary packets arrival, the operational cost $\beta = 0$. Similarly, when the bandwidth price increases, the minimum operational cost increases and when price decreases minimum operational cost decrease.

When technologies are improved, service rate increases, under this condition minimum operational cost bound increases due to technology improvement. But when the technology

gets outdated, the service rate decreases, causing the minimum operational cost bound to decrease. For example, when the service rate is high, it can serve the PU in a short time and then continue serving many SUs. These increases operational cost. But when service rate is low ($\lambda_p = \mu$), under this situation it serves only the primary packets and $\beta = 0$.

At given service rate, PU arrival and bandwidth price, there is a minimum operational cost. If the operational cost increases with improved services, optimal secondary arrival increases, and minimum operational cost for Fig. 26 is 0.5. When the operational cost decreases at a given service rate, primary arrival and spectrum price, it decreases QoS and optimal SU arrival due to low QoS provided. Increasing operational cost without changing price gives the advantage to optimal SU arrival as it gets better services at lowest cost.

5.4.4. Effect of Service Rate μ on Optimal SU Arrival

The primary arrival (λ_p), spectrum price (α) and operational cost (β) and service rate (μ) are derived from PU packets arrival bounds as $\lambda_p < \mu < \lambda_p + \frac{\beta}{\alpha}$ whereby, service rate bound changes depending on primary packets arrival. For example, when $\lambda_p = 0$, $\alpha = 5$ and $\beta = 1$, the service rate boundaries are given as $0 < \mu < 0.2$, but when $\lambda_p = 0.1$, the service rate bound is $0.1 < \mu < 0.3$.

From Fig. 27, it can be shown that for the service rate from 0.12 to 0.16, the optimal secondary arrival decreases. At the service rate from 0.16 to 0.245, the optimal secondary arrival increases. When the service rate μ approaches the upper bound, the optimal secondary arrival decreases sharply. This can be described as follows; when the service rates are low, the optimal secondary packets arrival are few or low since the low service rate provide low service quality. But as service rate increases optimal SU packets arrival increases but when service rate approaches upper bound, the quality of service provided is very high but optimal secondary arrival decreases. This is due to the fact that, when quality of service increases, operational cost increases, which causes the price to increase. This situation deters the SUs' willingness to pay for the service. The graphs of priority queuing show that as long as the value of λ_p is less than the upper bound, not much variations in optimal SU packet arrival λ_s^*

is observed. The moment λ_p reaches the upper bound, there is steep increase in the optimal SU packets arrival λ_s^* .

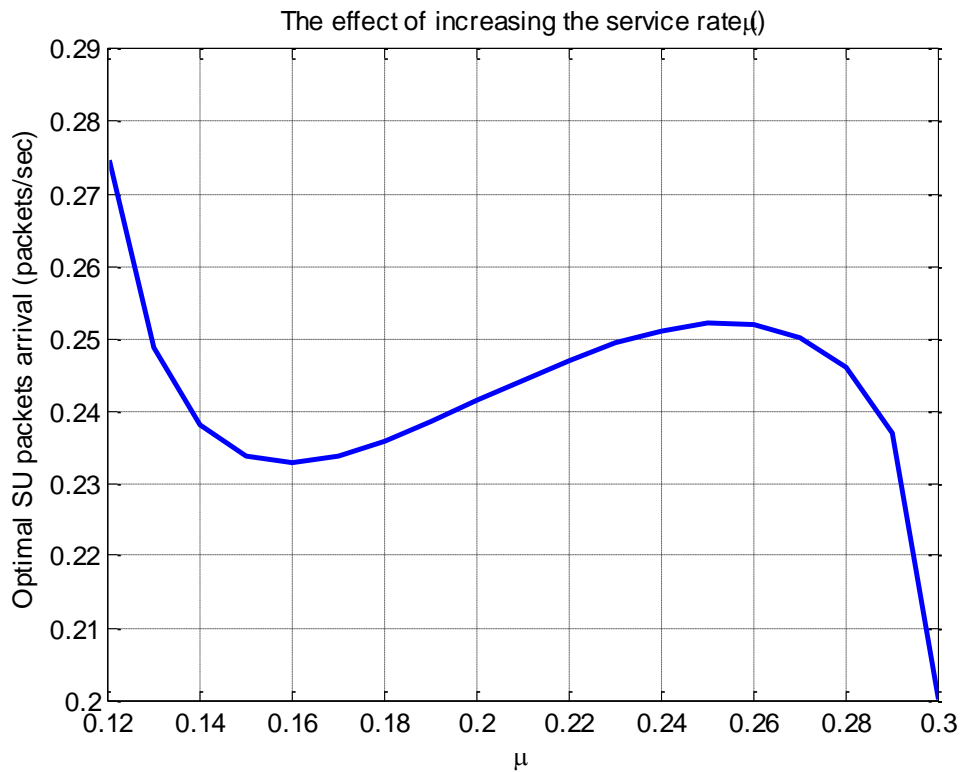

Figure 27: The effect of increasing the service rate (μ) on optimal SU packets arrival λ_s^* .

With the value of α at 0.5 the optimal secondary packet arrival (λ_s^*) is 0.72 with any increase in α there is steep fall in the optimal secondary packet arrival λ_s^* to reach the knee point of the graph and thereafter there is an exponential fall up to the point when α reaches the upper bound. On the other hand, as the value of β increases from lower bound to upper bound the optimal secondary packet arrival λ_s^* linearly increases. With regard to the service rate μ , the value of μ at 0.12 gives the optimal secondary packet arrival λ_s^* of 0.275, with any increase in μ from lower bound there is steep fall in the optimal secondary packet arrival λ_s^* to approach knee point of graph and thereafter there is slight increase until it reaches another knee point after which there is a steep fall until the value of μ reaches the upper bound.

5.5. Conclusion

The M/D/1 system has been used to investigate the opportunistic access method for Primary and SUs of the broadband services in terms of bandwidth. The model is used to derive a

theoretical number of SU packets and their waiting time. The estimates for upper bound and lower bound of primary packets arrivals have been determined. The results show that optimal secondary packets arrival increase when either primary packets arrival increase or operational cost increases. This means that the better the quality of connectivity of the PU in terms of high throughput or quality, the higher the optimal number of secondary packets arrival that can be achieved. On the other hand, increasing the primary arrival lowers the free packet slots that could be used by SUs and this result in increased demand for bandwidth for optimal secondary arrival. Similarly, increasing the secondary arrival increases their operational cost. On the other side, when bandwidth price or service rate increases, optimum secondary arrival decreases and this is due to the fact that, the SU may not want to pay extra cost for the same service.

With the assumption that the primary user is the one responsible to bring the connectivity at the last-mile, the SUs will opportunistically utilize the connectivity when the primary user is not using it. This has been adopted from the cognitive radio techniques where the spectrum is efficiently utilized by making use of the unused packet slots at additional reward. It has been demonstrated using both analytical analysis and MATLAB simulation on how the owner can dimension and accommodate SUs in the network without affecting PU, there by getting a reward.

CHAPTER SIX

GENERAL DISCUSSION, CONCLUSION AND RECOMMENDATIONS

Summary

This Chapter presents the concluding remarks from the obtained findings, research contribution, recommendation and future research directions.

6.1. General Discussion

Rural and urban-underserved areas have not been able to utilize broadband connectivity due to various reasons ranging from lack of awareness, low purchasing power, lack of electrical power, high cost of devices and air charges. However, broadband or internet connectivity is a necessary service to achieve a knowledge society and solve the issues of scarce resources in education, health, financial services, and extension services to bridge the digital divide. The study builds on the telecentre model that has since the beginning of the twentieth century been introduced to serve the scattered users in the remote, rural and urban-underserved areas which seemed unattractive for investment.

The main objective of this research study was to develop a broadband last-mile connectivity model for efficient bandwidth utilization in rural areas, using Arusha, Tanzania as a case study. The main objective was further split into two specific objectives and these were achieved through two journal papers, one conference paper and two manuscripts both pending for publication. In each of these publications, a different methodology was adopted as will be discussed in the following paragraphs.

Objective 1: To Identify Connectivity Options and Bandwidth Utilization for Various User Experiences in Rural Areas.

This objective is addressed in Chapters 2 and 3, with Chapter 2 presenting the current status of the broadband last-mile connectivity and Chapter 3 presenting the utilization of broadband connectivity resources in the selected rural and urban-underserved areas in Arusha Tanzania. The details of the peer reviewed journal papers making these two chapters and the summary of results and methodology used are given hereunder.

Paper 1: Overview of Broadband Connectivity for Rural and Urban-Underserved Areas- Tanzania as a Case Study

This paper provides an overview or state of the art work that has reviewed technologies, initiatives, and models available to achieve last-mile broadband connectivity to rural and urban-underserved areas. The infrastructure and policy readiness has also been discussed. It has been established that the current national strategies and the ICT policies and other related frameworks are sufficient to bring broadband services to rural and urban-underserved areas in the country. It is also discovered that the infrastructure is satisfactory but the utilization to majority in the community is still low. Also discovered in this study is that various initiatives towards rural and urban-underserved connectivity failed mainly due to issues related to lack of ownership and involvement of the intended users, awareness and low education level of the majority. This study contend that with the available infrastructure and right policies, utilization of available private and public networks to extend services to the neighborhood will speed up the universal communication access process. This paper employed a literature review as a research methodology using available research in the study area, government documents, reports, policy documents, acts and other information from websites and offices through physical visits. Where necessary structured interview and site visits were used. It is this paper that has provided a foundation for the whole study.

Paper 2: Utilization of Broadband Connectivity in Rural and Urban-Underserved: The Case of Selected Areas in Arusha-Tanzania, Published in The International Journal of Computing and Digital Systems of the University of Bahrain.

This paper takes up from paper I that, broadband last-mile connectivity to some extent is available even in remote areas but users are very few, normally anchor customers like private schools, colleges and hotels. This paper employs questionnaires, site visits and structured interview to decision makers from- the ministry (MoWTC), UCSAF and TCRA to dig into the actual status of broadband connectivity in the study area. The collected data is used to measure the theoretical capacity that could be used by neighboring communities but because something is lacking like the policy or guideline and motivation, the connectivity remain solely for the few customers. This paper contends that a significant amount of bandwidth is in the vicinity of users in the study area but is underutilized. This study proposes a need for a model to guide investors to create demand in these areas and achieve universal broadband access for all.

Objective 2: To Design and Simulate The Broadband Last-Mile Connectivity Model for Delivering Acceptable User Experience in Rural Areas.

This objective is achieved through Chapter 4 and 5. Chapter 4 gives a shared service model while Chapter 5 gives an optimized model of the same. Results from MATLAB simulations are explained in Chapter 5 and findings show that with proper optimization techniques, it is possible to provide services in low income areas achieving both quality and affordable prices through resource sharing and utilizing the unused chunks of bandwidth using cognitive networks analysis.

This objective has also been achieved through one (1) conference paper, extended into a manuscript (Chapter 4) and additional separate manuscript (Chapter 5) and collectively, the two manuscripts have realized the broadband last-mile connectivity model. Details for each manuscript is given in the following paragraphs.

Manuscript 1: Affordable broadband connectivity model for rural areas

This manuscript (Chapter 4) proposes the broadband last-mile connectivity shared model to utilize the available connectivity. It evaluates six technology frameworks (MMDS, FTTH, WiMAX, Microwave radio, TVWS and Wi-Fi) in terms of coverage, RF requirement, throughput, installation cost, proneness to vandalism and supported services to guide the proposed model. Finally the RBSB model is proposed that adopts the telecentre shared service model. This model can be achieved through the implementation of the proposed priority and service quality for the users in Table 3 of Chapter 4. The implementation part is beyond the scope of this study.

Manuscript 2: A Model for Optimization of Bandwidth Utilization in Rural and Urban-Underserved Areas Using Queuing Analysis

This manuscript presents the design and simulations of the optimized bandwidth RBSB model that employs the M/D/1 queuing techniques to opportunistically dimension subscribed bandwidth capacity in a service centre. The presented RBSB optimized model demonstrate how more users (SUs) can be introduced in a channel belonging to a PU without affecting the PU's QoS through trading off the operational cost and pricing of the service to SUs to maintain the overall QoS of the centre users. This model can be used to solve the problem of low utilization of broadband services in rural and urban-underserved areas by choosing the service price that is affordable at the expense of varying user experience to SUs.

Generally, the proposed model not only ensures efficient utilization of bandwidth resources but is a way to aggregate users at a common centre, especially in low density areas. The paper employs a scientific design and simulation using MATLAB software. It has been shown that under this optimized solution an entrepreneur can provide services to users with different priorities, the one with a high priority being a PU, owning the link and the SUs who make use of the link when it is idle or when the PU is not transferring any packet at a particular time slot.

6.2. Research Contributions

Findings of this research contribute to the body of knowledge and development initiatives especially for rural and urban-underserved areas or communities. It has been discovered that, still there are majority of people not connected with the internet services hence exhibiting a digital divide. It is also instilling to the regulatory body to see to it that special attention is needed despite the coverage of cellular mobile networks as the impediments to internet access are more than the coverage itself. On the other hand, the study has applied the cognitive radio network theory to demonstrate that the same can be used to allocate unused bandwidth for the users that are unlicensed or secondary.

Second major contribution is tied to the fact that, although bandwidth is abundant in a country like Tanzania, it needs to be paid for. This cost component is what limits what is actually available for consumption to various users with limited income. The costing of the services in the RBSB optimized model is expected to be much lower due to the utilization of idle bandwidth that would otherwise get lost but instead provide additional income to the RBSB. This study unveils the fact that the available information on coverage and data on penetration in increasing percentages could be misleading in some areas.

Third major contribution of this work is the extensive literature review on broadband last-mile connectivity for rural and underserved areas that was missing at the beginning of this study. Future researchers are expected to benefit a lot from this dissertation.

6.3. Concluding Remarks

Utilization of available connectivity and optimum utilization of bandwidth resources are aspects that are very important to communities with limited income. Making use of the already paid for resource allows for avoidance of some costs that are already paid for by other

users and also as a result it speeds up the process of service provision in unprofitable areas. Since governments aim to minimize the digital divide through shared services and universal access funding, it is necessary for the government to look into the formalization of the shared services as an obligation to users in the rural areas just like the MNOs levy for UCSAF. The proposed model has taken into consideration the fact that all communities regardless of location need ICTs services for their socio economic development. It has also assumed among others, the fact that the available bandwidth is not unlimited since it needs to be paid for. The limitation comes from the amount that users can pay for, hence the need to be shared and optimized.

6.4. Recommendations

The recommendations from this study are in two main categories; first is the policy advice directed to the government requiring policy adjustments and secondly, the operational advice to network operators.

6.4.1. Policy Advice to the Government

- i) The proposed model requires the intervention of the government through TCRA to recognize and authorize this type of resource sharing to harmonize the process and sensitize the communities and entrepreneurs to use the model and measure the performance.
- ii) On the other hand, it is recommended that the universal communication access funds such as UCSAF should consider training, funding and monitoring the RBSBs for sustainable universal communication access to rural and urban-underserved areas.
- iii) It is also recommended that all high capacity private connectivity in the remote and rural unconnected communities should be shared with entrepreneurs who can provide the same services from their termination and possibly allow their buildings to be used to host the broadband broker.
- iv) In addition, to achieve the universal access in Tanzania in terms of broadband connectivity, there should be bandwidth optimized multi- service centres and the establishment of business models that will allow small scale entrepreneurs

available in rural areas to provide services at a scale sufficient for the area and for the capital available.

- v) It is recommended that all initiatives aiming at connecting unconnected communities should first consider the utilization of broadband links whose part of investment cost has already been paid for by anchor customers. This will bring down the cost of connecting prospective users and speed up the realization of the universal communication access.

6.4.2. Operational Advice to Network Operators (NOs)

- i) In areas that are completely not yet connected, it is recommended that Network Operators need to consider the RBSB model when planning for service provision in the under-served areas so that the unseen demand is identified in the form of shared service instead on individual users.
- ii) It is recommended also that the NOs should include in their CSR budget for training and initial startup funding to RBSBs through competition among interested business men and women.

6.5. Future Work

Future work is on development of a business model for the RBSB, implementation of the optimized RBSB pilot model and performance testing and evaluation. Further research is required to improve the model to a business case showing detailed profitability and break even values so as to motivate the entrepreneurs. Furthermore, investigation is required to analyze the cost benefit analysis including all services that could be offered at the RBSB and their associated costs and returns to get a typical scenario that will attract investors.

REFERENCE

- Ahmadi, S. (2009). An Overview of Next-Generation Mobile WiMAX Technology. *IEEE Communication Magazine*. 47, pp. 84–98. <https://doi.org/10.1109/mcom.2009.5116805>.
- Armanious, E. (2001). Adaptive Modulation, Adaptive Coding, and Power Control for Fixed Cellular Broadband Wireless Systems.
- Bates, R.J. (2002). Broadband Telecommunications Handbook.
- Briglauer, W. (2014). The Impact of Regulation and Competition on the Adoption of Fibre-Based Broadband Services: Recent Evidence from the European Union Member States, *Journal of Regulatory Economic*. 46, 51–79.
- Briglauer, W., Dürr, N., Falck, O. and Hüschelrath, K. (2016). Does State Aid for Broadband Deployment in Rural Areas Close the Digital and Economic Divide?
- Broadband Commission for Sustainable Development. (2017). The State of Broadband 2017: Broadband Catalyzing Sustainable Development. ITU/UNESCO.
- Byanyuma, M., Kalolo, S., Mrutu, S. I., Nyakyi, C. and Sam, A. (2013). Affordable Broadband Connectivity for Rural Areas, In: Information Science, Computing and Telecommunications (PACT), 2013 Pan African International Conference. *IEEE*. pp. 62–65.
- Byanyuma, M., Yonah, Z. O., Simba, F. and Trojer, L. (2018). Utilization of Broadband Connectivity in Rural: The case of Selected Areas in Arusha-Tanzania, in: *International Journal of Computing and Digital Systems*. University of Bahrain.
- Byanyuma, M., Yonah, Z. O., Simba, F. and Trojer, L. (2016). Utilization of Broadband Link Capacity Terminated at the Vicinity of Rural and Underserved Areas, in: Current and Emerging Technologies for Social-Economic Development. *Presented at the 2nd International ICT Summit*. Dar es Salaam, Tanzania.
- Chang, J. M., Lai, C. F., Chao, H. C. and Chen, J. L. (2012). Optimized Path Selection Mechanism for IEEE 802.16 j Multi-Hop Relay Networks, in: Communications (ICC), IEEE International Conference. *IEEE*. pp. 1938–1942.

- Chaudhari, K. (2011). E-Governance in Rural India: Need of Broadband Connectivity Using Wireless Technology. *Wireless Engineering Technology*. 02, pp. 212–220. <https://doi.org/10.4236/wet.2011.23029>.
- Chavez, A., Littman-Quinn, R., Ndlovu, K. and Kovarik, C. L. (2016). Using TV White Space Spectrum to Practise Telemedicine: A Promising Technology to Enhance Broadband Internet Connectivity within Healthcare Facilities in Rural Regions of Developing Countries. *Journal of Telemedicine and Telecare*. 22, 260–263.
- Chawinga, W. D. and Zozie, P. (2016). Information Needs and Barriers to Information Sources by Open and Distance Learners: A Case of Mzuzu University, Malawi: Original Research. *South African Journal of Information Management*. 18, 1–12.
- Cobo, L., Chamberland, S. and Ntareme, A. (2012). Low Cost Fibre-To-The-Node (FTTN) Access Network Design, in: Telecommunications Network Strategy and Planning Symposium. *XVth International. IEEE*, pp. 1–4.
- Daynes, W. and Boyle, J. (2016). Connecting the Dots.
- Deichmann, U., Goyal, A. and Mishra, D. (2016). Will Digital Technologies Transform Agriculture in Developing Countries? *Agricultural Economics*. 47, 21–33.
- Donner, J. (2008). Research approaches to mobile use in the developing world: A review of the literature. *Information Society*. 24, 140–159.
- Dymond, A. and Oestmann, S. (2002). Universal Access and Rural Communication Development Funds: Success Factors Worldwide and Practical Insights from Uganda. *Intelecon Research Consulting Ltd*. Vancouver.
- Economides, N. (2015). Mobile Money in Tanzania, pp. 1–57.
- Eduardo, J. and Vargas, G. (2014). Universal Broadband Access in Developing Countries – The Case of Bolivia.
- Filippini, I., Cesana, M. and Malanchini, I. (2013). Competitive Spectrum Sharing in Cognitive Radio Networks: A Queuing Theory Based Analysis, in: Communications and Networking (BlackSeaCom), First International Black Sea Conference. *IEEE*. pp. 238–242.

- Frank, I., Orunta, J. and Dike, I. (2013). Broadband Wireless Access Deployment Approach to Rural Communities. *Journal of Computer Networking*. 1, pp. 38–45. <https://doi.org/10.12691/jcn-1-3-1>.
- Ghazisaidi, N., Maier, M. and Assi, C. (2009). Fibre-Wireless (FiWi) Access Networks: A Survey. *IEEE Communication Magazine*. 47, pp. 160–167.
- Gospic, B. N., Bogojevic, D. Serbia, A. P. and Virginia, N. (2010). Global Urban and Rural Telecommunications Development : Identification of a Digital / Broadband Gap in Serbia Promoting Technical Leadership Expertise in Local Chapters : The Distinguished Lecturer Program Experience in North America Seattle 1–8.
- Halotel. (2017). Halotel Home Page. <http://halotel.co.tz/en/service/mobile/Halo-University-Pack> (accessed 4.24.17).
- Hammond, A. and Paul, J. (2006). A New Model for Rural Connectivity. *World Resources Institute*.
- Harris, R. W., Yogeessvaran, K. and Lee, L. W. (2007). Telecentres for National E-Inclusion in Malaysia. Retrieved Sept. 9, 2007.
- Huang, X. L., Wu, X., Wu, J., Xu, Y. and Wang, M. (2014). Queuing Theory Based Spectrum Allocation in Cognitive Radio Networks, Wireless Communications and Signal Processing (WCSP), Sixth International Conference. *IEEE*. pp. 1–6.
- Investopedia. (2016). Capacity Utilization Rate. <http://www.investopedia.com/video/play/capacity-utilization-rate/>.
- ITU. (2017a). Measuring the Information Society. *International Telecommunication Union*.
- ITU. (2017b). ITU Statistics. *International Telecommunication Union*.
- ITU. (2013). Measuring the Information Society. *International Telecommunication Union*.
- ITU. (2012). Internet Users in 2012 as a Percentage of a Country's Population. *International Telecommunication Union*.
- ITU/UNESCO. (2013). The State of Broadband 2013: Universalizing Broadband.

- Johnson, D. L., Pejovic, V., van Stam, G. and Belding, E. M., (2011). Traffic Characterization and Internet Usage in Rural Africa, in: Proceedings of the 20th International Conference Companion on World Wide Web. ACM, pp. 493–502.
- Jones, S. (2006). Infrastructure Challenges in East and South Asia. *Institute of Development Studies Bulletin*. 37, pp. 28–44.
- Joyce-Gibbons, A., Galloway, D., Mollel, A., Mgoma, S., Pima, M. and Deogratias, E. (2017). Mobile Phone Use in Two Secondary Schools in Tanzania. *Education Information Technology*. pp. 1–20.
- Kapondera, S. K. and Hart, G. (2016). The Use of Multipurpose Community Telecentres and Their Services in Malawi: The Case of Lupaso Community Telecentre. *South African Journal of Libraries and Information Science*. 82, pp. 13–25.
- Komunte, M. (2015). Usage of Mobile Technology in Women Entrepreneurs: a case study of Uganda. *African Journal of Information System*. 7.
- Kondoro, J. W. A. and Nungu, A. (2006). ICT4RD Project : Provision Of ICT Access to Rural Tanzania, in: 4th International Workshop on Open Access.
- Kowero, A. B. (2012). Exploiting the Potentials of the National Information and Communication Technology Broadband Backbone (NICTBB) in Tanzania. *Tanzania Country Level Knowledge Network (CLKNET)*.
- Kwesigabo, E. M., Rao, K. G., Rao, B. B. and Chandan, K. (2017). Access Analysis of Secondary Users with an Opportunistic perspective in Cognitive Radio Networks. *International Journal Computational Intelligence Research*. 13, pp. 445–461.
- Lakhal, S. and Idrissi, A. (2014). Queues management of secondary users in a Cognitive Radio Network, in: Next Generation Networks and Services (NGNS), 2014 Fifth International Conference. *IEEE*. pp. 302–307.
- LaRose, R., Gregg, J. L., Strover, S., Straubhaar, J. and Carpenter, S. (2007). Closing the Rural Broadband Gap: Promoting Adoption of the Internet in Rural America. *Telecommunication Policy*. 31, pp. 359–373. <https://doi.org/10.1016/j.telpol.2007.04.004>.

- Le-Ngoc, S. and Le, B. N. (2009). Fixed Broadband Wireless Access for Wide Area Coverage and Last Mile Solutions, Sixth International Conference in Information Technology, pp. 1378–1383. <https://doi.org/10.1109/ITNG.2009.42>.
- Lewis, C. (2013). Universal Access and Service Interventions in South Africa: Best Practice, Poor Impact (SSRN Scholarly Paper No. ID 2663052). *Social Science Research Network*. Rochester, NY.
- Lwoga, E. T. (2010). Bridging The Agricultural Knowledge and Information Divide: The Case of Selected Telecentres and Rural Radio in Tanzania. *The Electronic Journal on Information Systems in Developing Countries*. 43, 6, pp. 1-14.
- Machuve, D. Z., Zlotnikova, I. and Nyambo, D. (2014). Monitoring and Evaluation of the E-Readers Project in Rural Tanzania, In Pan African Conference on Science, Computing and Telecommunications (PACT), *IEEE*. pp. 62–67.
- Magnér, J. (2008). Rural-Urban Migration in the Context of Babati Town, Tanzania: Causes and Effects on Poor Peoples' Quality of Life.
- Maleki, S., Chatzinotas, S., Evans, B., Liolis, K., Grotz, J., Vanelli-Coralli, A. and Chuberre, N. (2015). Cognitive Spectrum Utilization in Ka Band Multibeam Satellite Communications. *IEEE Communication Magazine*. 53, pp. 24–29.
- Manasseh, E. (2016). Development of TV White Space Technology. *The Regulator*.
- Mandioma, M. T., Krishna Rao, G. S. V. R., Terzoli, A. and Muyingi, H. (2006). A Study on WiMax Implementation at Dwesa-Cwebe Rural Areas of Eastern Cape of South Africa, in: TENCON 2006. IEEE Region 10 Conference. pp. 1–3. <https://doi.org/10.1109/tencon.2006.344085>.
- Masonta, M. T., Kliks, A. and Mzyece, M. (2013). Television White Space (TVWS) Access Framework for Developing Regions, in: IEEE AFRICON 2013 WORKSHOP: Cognitive Radio and Opportunistic TVWS Broadband Wireless Networks for Sustainable Broadband Provision in Emerging Economies.

- Masonta, M. T., Kola, L. M., Lysko, A. A., Pieterse, L. and Velempini, M. (2015a). Network performance analysis of the Limpopo TV White Space (TVWS) Trial Network, in: AFRICON, *IEEE*. pp. 1–5.
- Masonta, M. T., Ramoroka, T. M. and Lysko, A. A. (2015b). Using TV White Spaces and e-Learning in South African Rural Schools, in: IST-Africa Conference, *IEEE*. pp. 1–12.
- Mbarawa, M. M. (2010). Towards a Broadband Ready Tanzania: Status, Projects, Future Plans.
- MCST. (2013). Ministry of Communication, Science and Technology (MCST) website.
- MCST. (2012). The National ICT Back bone (NICTBB) Project.
- MCST/CITCC. (2010). The National ICT Broadband Backbone Infrastructure Development - Technical Proposal for Phase III.
- Mercer, C. (2006). Telecentres and Transformations: Modernizing Tanzania through the Internet. *African Affairs*. 105, pp. 243–264.
- Milne, C. (2006). Improving Affordability of Telecommunications: Cross-Fertilisation between the Developed and the Developing World.
- Mosha, G. and Bea, G. (2014). Barriers of using Internet Resources in Higher Learning Institutions: A Case of Mzumbe University in Morogoro Region in Tanzania, *Information and Knowledge Management*. pp. 64–71.
- Moturi, C. A. and Nyota, C. T. (2012). Filling the Digital Divide in Rural Connectivity : Case for Last Mile Mobile Broadband Subscription 6, pp. 46–63.
- Mtebe, J. S. (2013). Exploring the Potential of Clouds to Facilitate the Adoption of Blended Learning in Tanzania. *International Journal of Education Research*. 1, pp. 1–16.
- Mudali, P., Nyandeni, T. C., Ntlatlapa, N. and Adigun, M. O. (2009). A Test-Bed Evaluation of Connectivity Strategies for Infrastructure Wireless Mesh Networks.
- Naik, G. (2011). Designing a Sustainable Business Model for E-Governance Embedded Rural Telecentres (EGERT) in India. *Indian Institute of Management Review*. 23, pp. 110–121. <https://doi.org/10.1016/j.iimb.2011.04.001>.

- NBS. (2016). Tanzania in Figures 2015. Tanzania National Bureau of Statistics.
- Ndiomo, E., Junior, M. and Guo, B. (2013). Research on the Lifetime Estimation of Secondary Connections Using the PRP M/G/1 Queuing Network Model. pp. 800–803.
- Ngowi, E., Mwakalobo, A. and Mwamfupe, D. (2015). Making ICTs work for Agro-pastoral Livelihood: Using the Telecentre as Learning Tool for Agro-pastoralists Communities in Tanzania. *Journal of Sustainable Development*. 8, 89.
- Nika, A., Dimopoulos, S., Johnson, D. L. and Belding, E. M. (2012). Time-Shifting Traffic to Improve Utilization in Rural Area Networks.
- NSN. (2008). “Nokia Siemens Networks Village Connection - Affordable Voice and Internet Connectivity for Rural Villages”. Nokia Siemens Networks White Paper (White paper). *Nokia Siemens Networks*.
- Nungu, A., Brown, T. and Pehrson, B. (2011). Business model for developing world municipal broadband network-a case study, in: Global Information Infrastructure Symposium (GIIS), *IEEE*. pp. 1–7.
- Nungu, A. M., Pehrson, B. and Genesis, N. (2008). Serengeti Broadband. Proc. Second ACM SIGCOMM, *Proceedings of the second ACM SIGCOMM Workshop on Networked Systems for Developing Regions*. 08, pp. 37–42. <https://doi.org/10.1145/1397705.1397716>.
- OECD (2008). Broadband Growth and Policies in OECD Countries. <https://doi.org/10.1787/9789264046764-en>.
- Oh, S. W., Ma, Y., Tao, M. H. and Peh, E. (2016). TV White Space: The First Step Towards Better Utilization of Frequency Spectrum. *John Wiley & Sons*.
- Olwal, T., Masonta, M., Mfupe, L. and Mzyece, M. (2013). Broadband ICT Policies in Southern Africa: Initiatives and Dynamic Spectrum Regulation, in: IST-Africa Conference and Exhibition (IST-Africa), *IEEE*, pp. 1–8.
- Park, S., Jung, M. C. and Lee, J. Y. (2013). Enabling Sustainable Broadband Adoption in Rural Areas: A Case Study of Information Network Villages in South Korea. *Australia Policy Online*. <http://apo.org.au/node/69684>.

- Patil, K., Skouby, K. E. and Prasad, R. (2013). Cognitive Access to TVWS in India: TV Spectrum Occupancy and Wireless Broadband for Rural Areas, 16th International Symposium on Wireless Personal Multimedia Communications (WPMC). *IEEE*, pp. 1–5.
- Pazi, S. M. and Chatwin, C. R. (2013). Assessing the Economic Benefits and Challenges of Tanzania’s National ICT Broadband Backbone (NICTBB). *International Journal of Information and Computer Science*. 2, pp. 117–126.
- Philip, L., Cottrill, C., Farrington, J., Williams, F. and Ashmore, F. (2017). The Digital Divide: Patterns, Policy and Scenarios for Connecting the ‘Final Few’ in Rural Communities Across Great Britain. *Journal of Rural Studies*. 54, pp. 386-398.
- Prieger, J. E. (2013). The Broadband Digital Divide and the Economic Benefits of Mobile Broadband for Rural Areas. *Telecommunication. Policy*. 37, pp. 483–502. <https://doi.org/10.1016/j.telpol.2012.11.003>.
- Qiao, L. and Koutsakis, P. (2011). Adaptive Bandwidth Reservation and Scheduling for Efficient Wireless Telemedicine Traffic Transmission. *IEEE Transaction of Vehicular Technology*. 60, 632–643. <https://doi.org/10.1109/TVT.2010.2095472>.
- Rakesh, J. and Dalal, U. (2010). A Survey of Mobile WiMAX IEEE 802.16 m Standard. *International Journal of Computer Science and Information Security*. Vol. 8 No. 1, USA. ISSN 1947 5500, <https://arxiv.org/abs/1005.0976>.
- Ramachander, S. (2007). Rural Connectivity in India: The n-Logue example. *Indian Journal of Radio and Space Physics*. Vol.36, pp. 188-191.
- Rayes, A. (2000). Common Management Architecture for Third Generation Wireless Networks, in: Wireless Communications and Networking Conference (WCNC), *IEEE*. pp. 1060–1064 vol.3. <https://doi.org/10.1109/wcnc.2000.904774>.
- Roberts, S., Garnett, P. and Chandra, R. (2015). Connecting Africa Using the TV White Spaces: from Research to Real World Deployments, in: Local and Metropolitan Area Networks (LANMAN). IEEE International Workshop. *IEEE*. pp. 1–6.

- RSA. (2013). South Africa Connect: Creating Opportunities, ensuring inclusion. Creating Opportunities, Ensuring Inclusion, South Africa's Broadband Policy. Department of Communications, Republic of South Africa.
- Schneir, J. R. and Xiong, Y. (2016). A Cost Study of Fixed Broadband Access Networks for Rural Areas. *Telecommunication. Policy*. 40, pp. 755–773.
- Schuman, R. and Kende, M. (2013). Lifting Barriers to Internet Development in Africa: Suggestions for Improving Connectivity. *Analysis Mason Limited and the Internet Society (ISOC)*.
- Sedoyeka, E. and Hunaiti, Z. (2011). Low Cost Broadband Network Model Using WiMAX Technology. *Government Information Quarterly*. 28 (3), pp. 400–408.
- Shukla, S., Khare, V., Garg, S. and Sharma, P. (2013). Comparative Study of 1G, 2G, 3G and 4G. *Journal of Engineering, Computers & Applied Science*. 2, pp. 55–63.
- Siebörger, I. and Terzoli, A. (2010). WiMAX for rural SA: The experience of the Siyakhula Living Lab, in: Southern African Telecommunication Networks & Applications Conference: A Society Enabled by Innovation and Applications, Stellenbosch, South Africa.
- Simba, F., Mwinyiwiwa, B. M., Mjema, E. M., Trojer, L. and Mvungi, N. H. (2011). Broadband Access Technologies for Rural Connectivity in Developing Countries. *International Journal of Research and Reviews in Computer Science*. 2(2), pp. 312–319.
- Simba, F., Trojer, L., Mvungi, N. H., Mwinyiwiwa, B. M. and Mjema, E. M. (2009). Strategies for Connectivity Configuration to Access e-Learning Resources: Case of Rural Secondary Schools in Tanzania. *Proceeding of the World Academic Science and engineering Technology*, 54, pp. 789–794.
- Simba, F., Trojer, L. and Yonah, Z. O. (2012). Sustainable Broadband Connectivity Model for Rural Areas of Tanzania. *African Journal of Science, Technology, Innovation and Development*. 4, pp. 150–172.

- Soma, P., Baum, D. S., Erceg, V., Krishnamoorthy, R. and Paulraj, A. J. (2002). Analysis and Modeling of Multiple-Input Multiple-Output (MIMO) Radio Channel Based on Outdoor Measurements Conducted at 2 - 5 GHz for Fixed Broadband Wireless Access Applications, *IEEE*. pp. 272–276.
- Stork, C., Calandro, E. and Gamage, R. (2013). The Future of Broadband in Africa. <https://doi.org/10.1108/info-10-2013-0055>.
- Suliman, I. and Lehtomaki, J. (2009). Queueing analysis of opportunistic access in cognitive radios, in: Cognitive Radio and Advanced Spectrum Management, *IEEE*. pp. 153–157.
- Sumbwanyambe, M., Nel, A. L. and Clarke, W. A. (2011). Optimal Pricing of Telecomm Services In A Developing Country: A Game Theoretical Approach, in: AFRICON, 2011. *IEEE*. pp. 1–6.
- TanzaniaInvest. (2016). Vietnamese Mobile Operator Halotel Announces 90% Coverage of Tanzania By End Of 2016. <http://www.tanzaniainvest.com/telecoms/vietnamese-telecom-operator-halotel-announces-3g-coverage-of-90-percent-in-tanzania-by-end-of-2016>.
- TCRA. (2018). Quarterly Communications Statistics Report, October-December Quarter.
- TCRA. (2011). Electronic and Postal Communications (Access, Co-location and Infrastructure Sharing).
- TCRA/BIID/TTN. (2011). Reaching to Rural (R2R): Connecting the Rural Tanzania through Telecentres.
- TDV2025. (2000). The Tanzania Development Vision 2025.
- United Nations. (2010). Information Economy Report.
- URT. (2016). The National Information and Communications Technology Policy. *The United Republic of Tanzania (URT)*.
- Vodacom. (2018). Vodacom Coverage Map. <https://olsuat.vodacom.co.tz/en/4g-coverage/>

- Wallstreetmojo. (2018). Capacity Utilization Rate Formula. Investment Banking Financial Modeling Training Courses Online.
- Wang, L. C., Wang, C. W. and Adachi, F. (2011). Load-balancing Spectrum Decision for Cognitive Radio Networks. *IEEE Journal of Selected. Areas in Communications*. 29, pp. 757–769.
- Wangwe, S. (2010). A Study on the Application of ICT in Improving Livelihood of the Poor and in Supporting Growth in General.
- Weiss, J. W., Yates, D. J., and Gulati G. J. J. (2016). Affordable Broadband: Bridging the Global Digital Divide, a Social Justice Approach, 49th Hawaii International Conference on System Sciences (HICSS). *IEEE*. pp. 3848–3857.
- Whitt, W. (1991). A Review of $L = \lambda W$ and Extensions. *Queueing Systems*. 9, pp. 235–268.
- World Bank. (2017). Rural Population (% of total population) Data.
- Wyche, S. and Steinfield, C. (2016). Why Don't Farmers use Cell Phones to Access Market Prices? Technology Affordances and Barriers to Market Information Services Adoption in rural Kenya. *Information Technology Development*. 22, pp 320–333.

-

APPENDICES

Appendix 1: Detailed Analysis for the Optimum Number of Secondary User (SU) Packets Arrival by Applying Differentiation by Parts the Equation

Determination of optimal profit gain on secondary admission we differentiate with respect to λ_s .

For simplification, let $X = \frac{\mu^2 T_D}{\mu - \lambda_p}$ and $Y = \mu - \lambda_p$

$$P = \left(1 + \frac{X}{(Y - \lambda_s)} \right) (\lambda_s \alpha - \beta)$$

Expand the terms

To determine optimal profit gain on secondary admission we differentiate with respect to λ_s

Apply differential by part

$$\text{From } UV = \frac{V\partial U - U\partial V}{V^2}$$

$$\frac{\partial P}{\partial \lambda_s} = \frac{(Y - \lambda_s)\partial(Y\alpha - \alpha\lambda_s^2 + \beta\lambda_s + X\alpha\lambda_s - Y\beta - X\beta) - (Y\alpha - \alpha\lambda_s^2 + \beta\lambda_s + X\alpha\lambda_s - Y\beta - X\beta)\partial(Y - \lambda_s)}{(Y - \lambda_s)^2}$$

$$\frac{\partial P}{\partial \lambda_s} = \frac{(Y - \lambda_s)(Y\alpha - 2\alpha\lambda_s + \beta + X\alpha) - (Y\alpha\lambda_s - \alpha\lambda_s^2 + \beta\lambda_s - Y\beta - X\beta)(-1)}{(Y - \lambda_s)^2} = 0$$

$$Y^2\alpha - 2Y\alpha\lambda_s + Y\beta + YX\alpha - Y\alpha\lambda_s + 2\alpha\lambda_s^2 - \beta\lambda_s - X\alpha\lambda_s + Y\alpha\lambda_s - \alpha\lambda_s^2 + \beta\lambda_s - Y\beta - X\beta + X\alpha\lambda_s = 0$$

After Simplification

$$\alpha\lambda_s^2 - 2Y\alpha\lambda_s + YX\alpha + Y^2\alpha - X\beta = 0$$

Optimal SU arrival derivation for priority queuing

Solve for λ_s using quadratic formula and secondary packet arrival rate must be positive and negative value is neglected.

From

$$\lambda_s = \frac{-b \pm \sqrt{b^2 - 4ac}}{2a}$$

$$a = \alpha$$

$$b = -2Y\alpha$$

$$c = YX\alpha + Y^2\alpha - X\beta$$

Substitutes in the above formula

$$\lambda_s = \frac{-(-2Y\alpha) \pm \sqrt{(-2Y\alpha)^2 - 4\alpha(YX\alpha + Y^2\alpha - X\beta)}}{2\alpha}$$

$$\lambda_s = \frac{2Y\alpha \pm \sqrt{4Y^2\alpha^2 - 4\alpha^2YX\alpha - 4Y^2\alpha^2 + 4X\alpha\beta}}{2\alpha}$$

$$\lambda_s = \frac{Y\alpha \pm \sqrt{X\alpha\beta - \alpha^2YX}}{\alpha} \Rightarrow Y \pm \sqrt{\frac{X\alpha\beta - \alpha^2YX}{\alpha^2}}$$

$$\lambda_s = Y \pm \sqrt{X \frac{\beta}{\alpha} - YX} \Rightarrow Y \pm \sqrt{X \left(\frac{\beta}{\alpha} - Y \right)}$$

Substitute the value of Y and X in the equation above

$$\lambda_s = (\mu - \lambda_p) \pm \sqrt{\frac{u^2 T_D}{(\mu - \lambda_p)} \frac{\beta}{\alpha} - \frac{\mu^2 T_D}{(\mu - \lambda_p)} (\mu - \lambda_p)}$$

$$\lambda_s = (\mu - \lambda_p) \pm \mu \sqrt{T_D \left(\frac{\beta}{(\mu - \lambda_p)\alpha} - 1 \right)}$$

Appendix 2: A Questionnaire for Internet Service Providers (ISP) in Arusha

A About the organization

- A.1 Name of Organization (optional).....
- A.2 Location
.....
- A.3 Type of Organisation
- a. Government Agency
 - b. Government Department
 - c. Primary School
 - d. Secondary School
 - e. College of Higher Learning
 - f. Health Centre
 - g. NGO
 - h. Hotel
 - i. Farm
 - j. Community Office
 - k. Other (Please specify).....
- A.4 Number of employees
- a. 0-10
 - b. 11-50
 - c. 50-150
 - d. More than 150
- A.5 What are the main/core services of the organization? Please list at most 5 in order of importance.
- a. Local Government Services
 - b. Teaching and Learning
 - c. Farming
 - d. Social Services
 - e. Business
 - f. Internet and call services
 - h. Health services
 - i. Tourism
 - j. Export of products and Services
 - k. Mining
 - l. Other, please specify
.....

B Internet Services Offered

- B.1 What types of Internet services are offered at your institution?
- a. Email
 - b. Internet Surfing
 - c. Video Conference
 - d. Telemedicine
 - c. e-learning
 - d. e-government services
 - e. Business marketing
 - f. Tour guiding
- B.2 What means of communication are used within and outside your organisation
- a. Email
 - b. Skype
 - c. Online Chat
 - d. Mobile calls and SMS
 - e. Fax
 - f. Mail (postal)
 - g. Personal visit

- B.3 If the means of communication is by internet, which connectivity technology is used?
- a. ADSL
 - b. DSL
 - c. Optic Fibre
 - d. Microwave Radio
 - e. VSAT
 - f. GSM/GPRS/EDGE
 - g. CDMA
 - h. UMTS
 - i. LTE
 - j. WiMAX
 - k. WiFi
- B.4 What can you say about the connectivity speed/bandwidth?
- a. Very Slow
 - b. Slow
 - c. Satisfactory
 - d. High Speed
 - e. Very High Speed
- B.5 If the speed of communication is not satisfactory, what do you think is the reason?
- a. Type of connectivity is limited
 - b. High contention ratio (sharing)
 - c. Others, please specify
- B.6 How much bandwidth is available for your internet connectivity?
- a. Less than 512Mbps
 - b. 1 Mbps
 - c. 2 Mbps
 - d. 5 Mbps
 - e. More than 5 Mbps
- B.7 How much do you pay per month
- a. Less than 50,000/-
 - b. 50,001/- ≤ 100,000/-
 - c. 100,001/- ≤ 500,000/-
 - d. 500,001/- ≤ 1,000,000/-
 - e. More than 1,000,000/-
- B.8 If bandwidth capacity was affordable, how much would be enough
-
- B.9 Who is your current Internet Service Provider (ISP)?
-
- B.10 Have you recently changed ISP?
- a. YES
 - b. NO
- B.11 If you answered YES in B.10 above, what were the reasons for doing so?
- a. Slow internet connectivity
 - b. Could not afford any longer
 - c. Poor customer care
 - d. Availability of other cheaper ways of internet connectivity
- B.12 How many computers (connected to the internet) does your organisation have?
- a. 1 computer
 - b. 2- 5 computers
 - c. 6-10 computers
 - d. More than 10 computers

C Computer Knowledge and Importance of Internet Connectivity

- C.1 How do you rate your computer knowledge (please tick only one)?
- a. Excellent
 - b. Very good
 - c. Good

- d. Average
- e. below average
- C.2 Do you think that access to the Internet can improve your working conditions?
- a. YES
- b. NO

If your answer is YES in C2 please answer question C3. Else go to question C4
Please tick a relevant statement of your choice (1-Strongly disagree, 2-disagree, 3-No opinion, 4-Agree, 5- Strongly Agree to indicate how you agree or disagree with the following statement.

C.3 What is your opinion about the use of the Internet connectivity in improving working conditions in your organisation		1	2	3	4	5
a.	Internet can be used to support learning					
b.	Internet provides many opportunities for self-employment					
c.	Use of Internet can assist in improving economic development					
d.	Internet helps to bring health care and other services close to the community through telemedicine and e-learning					
e.	Use of the Internet help in the exchange and sharing of new ways in farming techniques, pest control and agricultural exports.					
f.	Use of Internet helps in the marketing and promotion of products and services at very low cost					
g.	The Internet helps in tapping the potential of the tourism industry in terms of tourism promotion, marketing and sales					
h.	The Internet allows for access to information about disease diagnostics, health education and outbreaks hence reduces the time used to physically look for such advice from responsible personnel					

D Willingness and Financial Readiness

- D.1 If you were told that the internet can simplify and improve your work and bring about efficiency; are you willing to pay for such services?
- a. YE
- S
- b. NO
- D.2 If the answer in D.1 is YES; How much are you willing to pay per month (Tshs)?
- a. Below 100,000/=
- b. Between 101,000/= and 200,000
- c. Between 200,001/= and 500,000/=
- d. More than 500,000/=

E Service Time and Day

Please tick a relevant statement of your choice (1-Strongly disagree, 2-disagree, 3-No opinion, 4-Agree, 5- Strongly Agree) to indicate how you agree or disagree with the following statement.		1	2	3	4	5
a.	I use the internet all day since morning					
b.	I use the internet after work hours (e.g. after 4pm)					
c.	I use the Internet during the weekends					
d.	I use the internet anytime it is available					
c.	I do not mind to use the internet even at night only as long as it is efficient					

****THANK YOU FOR YOUR CONTRIBUTION TO THIS STUDY****

Appendix 3: The Map of the Study Area: Districts and Organisation Neighboring the Nelson Mandela African Institution of Science and Technology (NM-AIST)

i) The map of the study Area



ii) The Organizations Neighboring NM-AIST that Would Need Broadband Connectivity

