

2024-05-03

# Industrial -Based GSM Water Leakage Detection, Monitoring and Controlling System in Promoting Sustainability: A Case of Kenyan Industries

Dickson, Tuwei

Transdisciplinary Journal of Engineering & Science

---

<https://dspace.nm-aist.ac.tz/handle/20.500.12479/2703>

*Provided with love from The Nelson Mandela African Institution of Science and Technology*



# Industrial-Based GSM Water Leakage Detection, Monitoring and Controlling System in Promoting Sustainability: A Case of Kenyan Industries

**Tuwei K. Dickson<sup>1\*</sup>, Neema Mduma<sup>2</sup>, John K. Tarus<sup>3</sup>**

<sup>1</sup> Nelson Mandela African Institution of Science and Technology (NM-AIST), Arusha, Tanzania, [kipketert@nm-aist.ac.tz](mailto:kipketert@nm-aist.ac.tz)

<sup>2</sup> Nelson Mandela African Institution of Science and Technology (NM-AIST) Arusha, Tanzania, [neema.mduma@nm-aist.ac.tz](mailto:neema.mduma@nm-aist.ac.tz)

<sup>3</sup> Moi University, Eldoret, Kenya, [jktarus@mu.ac.ke](mailto:jktarus@mu.ac.ke)

\*Correspondence: [kipketert@nm-aist.ac.tz](mailto:kipketert@nm-aist.ac.tz)

Received 16 April 2024; Revised 3 May 2024; Accepted 3 May 2024

Available online 3 May 2024 at [www.atlas-tjes.org](http://www.atlas-tjes.org), doi: 10.22545/2024/00256

**Abstract:** *The current system for detecting and monitoring water leaks is manual and costly. Despite emerging new technological trends, many industries lack automated systems to detect, monitor, and control water leakage due to the high cost of maintenance and installation. This study aimed to develop an automatic, remote, and real-time detection, monitoring, and control system for water leaks. The system is made up of two nodes, one at the source and one at the destination or tap. The two nodes are made up of an ESP microcontroller, which is used to control all the connected components. The use of the ESP 32 microcontroller was efficient due to its ability to provide WI-FI. Aside from the solenoid valve, which was used to turn the water flow on or off in the event of leaks, the system also includes the FY-201 water flow sensor, which was used to gauge the amount of water flowing through the pipe. Water leakage is detected when the volume of water passing through the two sensors differs in terms of volume, indicating that a water leakage has just occurred. Thing-Board, an IoT-based platform used to monitor and visualize data from various devices connected, was used for real-time monitoring, visualization, and control. The developed system was tested with different water service providers, and the results showed that the system responds positively to water leakage parameters with the capability of monitoring water leakages in real-time, and can contribute to water sustainability and management efforts for industries.*

**Keywords:** Water Leakage Detection, Things Board, ESP32Microcontroller, FY-201 Water Flow Sensor

## 1 Introduction

Water is one of the most vital elements on the planet and plays an important role in our daily activities. It is a critical resource of the planet and serves many functions for human life. As such, effective management of water resources is essential for achieving United Nations Sustainability Goal 6 (SDG 6) – Clean Water and Sanitation, which aims to ensure universal access to safe and affordable drinking water and sanitation for all. However, water scarcity poses a significant threat to global sustainability and availability of the resource. Global water stress has been a pressing concern for many decades now and projections indicate a worsening scenario by 2040, (Figure 1). Therefore, there is an urgent need to develop measures and methods to ensure that this precious resource continues to sustain the human race's survival.

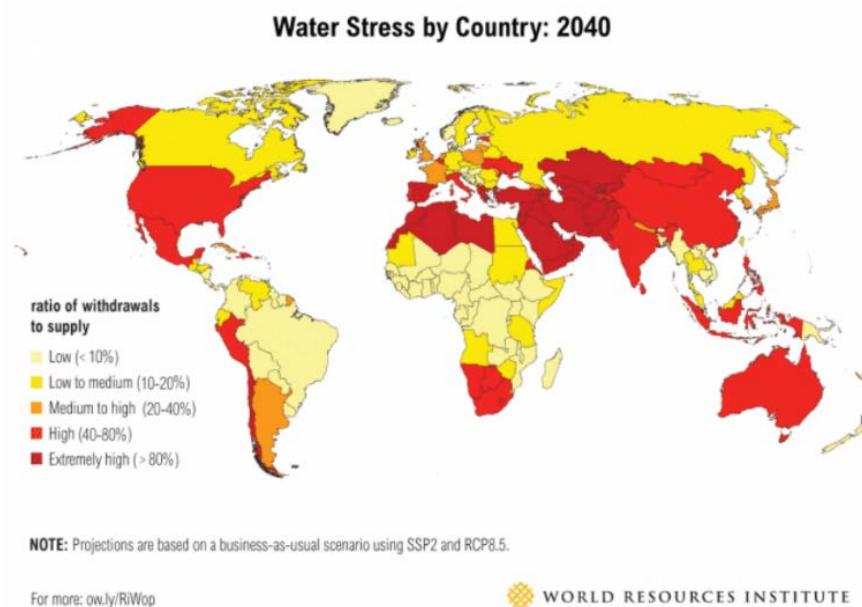

**Figure 1:** Forecast of Water Stress by 2040 (Source: <https://www.wri.org/insights/ranking-worlds-most-water-stressed-countries-2040>)

One of the main factors that fuel water scarcity and threaten global water sustainability is irresponsible water management. Collapsed and obsolete infrastructure, and lack of proper mechanisms to manage the scarce resource, have resulted in the world's water shortage [1]. Figure 2 depicts how water is mismanaged in East Africa as a result of leaks caused by poor infrastructure. Poor infrastructure contributes significantly to water leakages because there is no proper system

in place to manage water leakages in the face of water scarcity. Water leaks are the primary cause of water waste.



**Figure 2:** Water Leakages (<https://www.incefusa.org>)

Several countries have responded to water crises in various ways. Asian countries, particularly the Gulf countries (Bahrain, Kuwait, Oman, Qatar, Saudi Arabia, and the United Arab Emirates—UAE), which are considered the most water-stressed countries globally are trying to get their water through groundwater drilling, desalination of seawater, and wastewater treatment [2]. In Northern Africa, wind power is used to pump water out of wells and rivers, for domestic consumption and agriculture [3].

The most formidable intervention in the current times is technology [4]. As an intervention to the water crisis, argued that technological research to aid in providing a solution to the water shortage by using various devices to manage water is necessary. Unfortunately, there are various existing methods used to detect leakages that are still unable to provide the maximum mechanism to solve the water leakages problems, because they are incapable of detecting leakages [5]. Hence, there is a need to develop a system that can detect water leakages, especially in the pipeline systems despite the complexity of the water distribution networks, which is the underlying research problem in this project.

An assessment of all features of currently existing systems reveals clearly that there is a need to develop a system that can detect, monitor, and control water leakages. The proposed system consists of technologies that make use of the Internet of Things (IoT), developed to control water leakages. This study investigated a solution to develop a system capable of detecting, monitoring, and controlling water leaks. The objectives of the study were as follows:

1. To gather requirements for industrial-based GSM water leakage control system
2. To develop an industrial-based GSM water leakage system
3. To validate the developed industrial-based GSM water leakage control system

This study significantly contributes to advancing sustainability efforts in water resource management through the development of an automated, real-time water leakage detection, monitoring, and control system for Kenyan industries. By addressing the challenge of water leakages, this research directly supports SDG 6 targets, including efficient water use, pollution reduction, and sustainable water management. Through technological innovation, the study aims

to advance progress toward achieving universal access to clean water and sanitation, promoting environmental sustainability and human well-being.

## **2 Related Works**

Water leaks have been the subject of numerous research studies. For instance, a water pipeline leakage detection and control management system based on the 'Think Speak' cloud platform was demonstrated by [6]. This system allowed users to access uniform data by registering on their internet services and declaring their login credentials mainly passwords and consumer IDs. The parameters were displayed to minimize water waste in the long term, and the system was able to manage the apartment where it was built. The sensor used was able to be examined in real-time, depending on the various measured data. In this system, the specific person receives a message alerting the user to prevent water leakage when the water reaches a certain threshold limit.

Additionally, a similar study was carried out to develop a flow liquid meter sensor for water pipeline monitoring and leak detection by [7]. The system's objective was to increase system performance in terms of tracking and finding water leaks in underground pipes. Using a 5-meter length of polyvinyl chloride (PVC) pipe, the system's performance was tested. Where the normal flow of water in the pipe and the sensor are configured in such a way that each hole remains closed, the Arduino detects the presence of leaks every time the hole opens. During the stage where the system's performance was tested, the graph changed automatically every two seconds during the water monitoring flow rate. One of the limitations of this proposed system is that the system performance test, detecting location, was done ten times in each variation in the water flow rate, resulting in a waste of time.

Further research was conducted based on water leakage management [8]. The study used digital twin technology to manage water leakage. Where various sensors were placed near the input source and where network signal strength was reliable. Over 60-70 sensors were installed in various locations, and those sensors were linked with ESP8266 to collect all data and store it in a database. The sensors were intended to gauge the water flow rate through the pipe at various points and send the data to the firebase, where the digital twin would oversee and manage the data before sending it to the 3D Maya software, which was used to analyze the data. If a leak is detected, the system will send an email to the user informing them of the appropriate action to be taken. One of the limitations of this study is the use of many sensors in various locations, which increases the cost.

On the other hand, [9], conducted the research focused on the development of monitoring and controlling water leakages using a robotic arm. The proposed system consisted of an ATMEGA 328P microcontroller, a humidity sensor, a solenoid valve, and a Zigbee module installed in a water tank. Leak detection was accomplished by the humidity sensor, and user notification was accomplished by the buzzer ring as the information was shown on the LCD module. To open and allow water to flow, a solenoid was used. The Zigbee module was built into the robotic module. When the robotic arm receives a signal, it will proceed to the tank and seal the leak. The system was divided into two sections, namely transmitter, and receiver, with power connected to the microcontroller. The robotic arm opens and closes the leakages, and the motor driver is used to control and interface a DC motor with a microcontroller. The robotic occasionally receives signals that are too weak to move the arm to the tank and stop the leak, which is one limitation of the proposed system.

Similarly, research was conducted on improving wireless sensor networks' ability to detect and monitor leaks in underground water pipelines [10]. The study aimed to monitor water spillage by observing, discovering, and distinguishing spills using a remote wireless sensor. The upgraded remote sensor framework's goal was to locate underground water spillage individual water pipes that are monitored by the PC. Wireless sensor network: an interconnected network of sensor nodes that communicate wirelessly to collect data about their surroundings. It was made up of low-power and distributed nodes. The remote wireless sensors collect all of the information and send it to the central node, which then channels it to the PC for analysis and identification of the correct spillage position. On printed circuit boards, wireless sensors were arranged, and a PC displays data from various remote sensor types, including weight and sound. The responsible authority was the one to go and fix the spillage once the break had been identified. The benefit of this research is that it aimed to use wireless sensor node technology to collect various parameters and monitor them on a PC. One limitation that was overlooked is the security aspect, which could be tampered with or hacked into the sensor nodes to obtain data.

In order to address the sustainability effort, a conducted research study titled *Harnessing Ethical AI Surveillance for Climate Change Governmentality*[11]. Which they relooked at how sustainability can be achieved in the middle of different natural environments necessitating a shift in climate governmentality paradigms. In which they conduct research on how climate change can affect the human race, and how various bodies, including organizations, have emerged to deal with climate change, and how humans have developed various mechanisms to address the issue of sustainability by developing the complex modalities of techno-social agency that are at the root of the current climate crisis. They define climate governmentality as a wicked or difficult challenge that affects all levels of society and the world. They believe that nations with high levels of environmental resilience, complexity, and sustainability serve as conceptual hubs for addressing climate governmentality. As far as water sustainability is concerned, this study demonstrates that climate governmentality has a direct impact on water in the sense that the way various institutions and organizations implement their policies will have a significant impact on water sustainability, and this calls on all stakeholders to address this concern with great effort.

The research study titled the sustainable development goal [12]. The research trying to look on the various ways in which the water as one of the major resource rather elements that play a major role in human life, they illustrated that the sustainable development goal have been developed and it has been focused with the aim of bringing the change, especially the world of the climatic change and human intervention in progressing to achieve the sustainable development that will be to support the living in the planet. This paper argues and supports the idea that the sustainable development objective can be reached by establishing numerous international organizations and conferences whose main agenda is to meet the sustainable development goal. Furthermore, the study demonstrated that the sustainable development goals can be achieved and drastically revolutionized when the human being is at the center of the action in protecting the environment.

It goes on to demonstrate that a man has an obligation to improve the environment for present and future generations, and that doing so will increase the sustainability effort in addressing the sustainable development goals. Furthermore, the study looked at global ethics as one of the critical policies that each participating country must follow. It is based on the Belgrade Charter, which states that nations must be able to grow without prejudice to others, and that individual consumption should not harm others. Whereas the goal of this study was to analyze the index's

behavior in the five continents and provide a global overview of how countries are doing in each of those continents, the findings show that the agenda of the sustainability effort has been addressed seriously and measures have been developed to provide a conducive environment for the country to make this critical issue a source of concern. Finally, they emphasized that environmental education is critical in tackling sustainability challenges. The recommended metrics, such as awareness, knowledge, attitude, aptitude, evaluation capacity, and involvement, are practical and achievable.

The aim of this study titled water resources for sustainable development is to assess the level of water resources as a way of promoting sustainable development [13]. This study examined various factors that might contribute to water resource scarcity and came up with the Network Density as one of the sustainability indicators. This involving the hydrological information on the water level, discharge, sediment, and water quality where the necessary number of projects were integrated. In contrast, information about time series maxima or minima of a variable is particularly useful. Hydrological information is required for a variety of projects, including water engineering (dams, reservoirs, spillways, canals, diversions, and hydropower) as well as water quality, zoning, insurance regulations, and legislation. Furthermore, real-time access to hydrological data is required for water resource management, forecasting, and control.

They demonstrated that hydrological and water resource systems are viewed solely as components of a complex global system. As a result, a comprehensive approach is recommended in evaluating the strategy's implementation. They also shown that the network assessments project is the sole strategy for targeting and improving water resources as a sustainable development. They concluded that environmental, economic, demographic, socio-cultural, and institutional subsystems, when reconsidered, can play an essential role in water resource management as a means of achieving sustainability and enhancing sustainable development goals.

The study paper focused on determining the relative sustainability of renewable water resource systems [14]. The generally used measures of reliability, resilience, and vulnerability are used to quantify sustainability and determine if it is possible to maintain or increase the sustainability index. The approach enables one to measure or quantify, at least relatively, the amount to which sustainability is being or can be attained. The measure is based on the reliability, which they measured using a mathematical model in which they included formulas that function like the reliability of water resource systems to react in a specific way in order to establish the amount to which the value varies from one another. In order to determine which value is closest to the maximum value, that one will be considered to be dependable, with the chance that the sustainability effort has been completed through quantification. This study was limited to focusing on water permits in a way that makes it easier to measure sustainability.

The research conducted developed indicators to assess the sustainability of water use using the Drive-Pressure-Status-Impact and Response (DPSIR) mode[15]. According to the research article, the DPSIR is a model that describes a general chain that causes environmental difficulties between the origin and the results. Whereas this chain illustrates that societal, economic, and demographic development operate as drivers on the environment, putting pressure (P) on it and causing a change in its status, thereby affecting it. Essentially, the model looked at the interaction between socioeconomic development and the environment by analyzing the overall systems they comprised, and it is widely used in environmental systems to evaluate key indicators, implying

that sustainability is solely dependent on the socioeconomic development of the country and the continent as a whole. Based on this model, it was determined that the pressure on the environment, i.e., the use of water resources, can result in scarcity, which results in the Status (S) and ends with a negative Impact (I) on the environment, necessitating the intervention of the Response in order to prevent the depletion of water resources. Finally, the paper aims to assess the sustainability of regional water resources systems, with the DPSIR framework's recommendation to contribute to the understanding of the relationship between system "state" and "driver" factors, while also assisting hydrologists, water managers, policymakers, and the general public in understanding and managing different water systems more effectively and sustainably.

The research intends to propose information-based systems for water management in a test basin [16]. The study uses dynamic simulation model with its associated databased and water resource planning and optimization system established through web-based client-server implementation to support distributed use and easy access for multi-criteria optimization and decision support results clearly demonstrate how consistent and well-integrated set of advanced but practical Decision Support System (DSS) tools can be used for efficient optimal water management strategies and policies. Water Resource Modelling (WRM) is a topological network representation of a river basin, consisting of various node types, river reaches, and canals that connect them. Nodes depict items like sub-catchments, reservoirs, wells, diversion and confluences, as well as water-demanding locations like cities, tourist destinations, resorts, irrigation, districts, and significant businesses. The surface water network can be linked to one or more aquifers to simulate conjunctive use scenarios.

The findings of the optimization run and post-optimal analysis suggest that scenarios involving user education and training are more effective in addressing stakeholders' restrictions. Finally, the research study demonstrated how a consistent and well-integrated set of advanced but practical Decision Support System tools can be used for efficient optimal water management strategies and use policies, designed for participatory public decision-making.

This research study demonstrates that the human being is at the heart of adaptation, resilience, and sustainability[17]. The study proposed that adaptability, resilience, and sustainability have become concepts regarding the attributes of something and a purpose to be accomplished and maintained, as well as human intentionality in change processes. The concepts used to describe ecological hazards, financial risks, health dangers, and social risks are influenced by a variety of elements, including individual and community human factors. It goes on to add that the conceptual base of resilience, taken from biology, ecology, and psychology, is supplemented with descriptions of how to preserve human life and well-being in the political context of global change.

They concluded that adaptation and resilience are complex multidimensional concepts that have been interpreted differently according to diverse disciplinary approaches, leaving room for discussion on how humans can sustain nature while keeping in mind that sustainability is an integral part of living. Thinking along these lines, if people are given the opportunity to discuss concerns about sustainability efforts, it will create a platform for individuals to bring their concerns to the table in order to rethink the issues of sustainability, particularly the water resource, which appears to be depleted as a result of human interaction with nature.

According to a literature analysis of earlier studies, the usage of the IoT has not yet been fully realized, notably in the detection and monitoring of water leaks. Previous studies looked into using the IoT, robotic valve-control arms, and various types of sensors. Although they were able to manage the detection of water leaks to some extent, they encountered some limitations, including the inaccuracy of the sensor and the fact that their system did not automatically detect water leaks.



This study focused on and addressed the problem of automatic detection of water leakage and real-time monitoring of water leakage using the Internet of Things platform, or Thing speak, which was able to visualize the real-time data and allow the admin to remotely control the valve to prevent the loss of water due to the water leakage. In addition to water leakage detection system-related works, sustainability efforts-related works were included, which they thoroughly handled, demonstrating that the subject of sustainability is a critical matter that must be considered. As far as SDG goal number 6, which is access to clean, affordable water and sanitation for all, is concerned, this research demonstrates that many studies have been conducted in order to develop strategies and mechanisms for addressing water resource scarcity as a means of achieving its sustainability.

### **3 Methodology**

#### **3.1 Sample Size and Sampling Technique**

The study used non-probability sampling techniques in identifying the sample. A sample size of 15 respondents was used during data collection, with 10 engineers and 5 technicians participating in the survey. Purposive sampling was used to select the 15 respondents based on the researcher's subjective judgment since they had information of interest to the study.

#### **3.2 Data Collection Methods**

This study's data was generated from two different sources, namely primary and secondary data, which was critical in carrying out this study. The primary data helped to get the requirements for an industrial-based GSM water leakage system, which was the first objective of this project. The secondary data helped to clarify how industrial-based GSM water leakage systems worked in other similar studies and projects, and important to answer the three research questions. The main component of the research was the primary data collected from the respondents. The primary data was collected from the real environment of the staff, and this data has not been published. This information was gathered from engineers and technicians through interviews and questionnaires. Secondary data was gathered through document review from related works that have been published in various journals and company reports.

#### **3.3 System Development Approach**

The extreme programming approach, which is one of the agile methodology approaches, was used in this project. This approach was feasible because user requirements were created and met at each stage of development. During the development stage, users were incorporated, and every change requested was considered. Extreme programming was the best approach for this project because the software was tested as the project was being developed. The essential elements of extreme programming that best suited this project are the essence of continuous revision of the program, whereby if there were any changes in the requirements, it would be adjusted and continue with the development process, and secondly the element of short iteration, which involves delivering certain parts of the project to the user for any amendment within a specific time and making the necessary adjustment as shown in Figure 3.

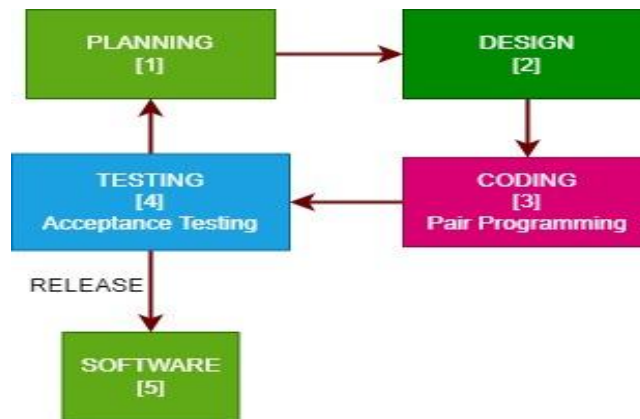

**Figure 3:** Extreme Programming Development Cycle (Source: <https://www.pinterest.com/pin/agile-methodology-extreme-programmingxp>)

### 3.4 Conceptual Diagram

The conceptual diagram presented in Figure 4 shows how the system works. It shows how node one and node two interact with one another, communicating and sharing data. They exchange data via the server, which will centrally manage communication between two node devices. The ESP32 board serves as the microcontroller for the data processing and transmission to the server after it is processed by the water flow sensor, which measures the amount of water flowing through the pipe. The mode of communication and data transmission is WIFI/GSM, and the communication protocol is Message Query Telemetry Transfer (MQTT), which is based on the subscriber and publisher principle. After the node one device at the source sends data to the server, the server communicates with the node two devices at the end of the tap to check if the amount of water received from the inflow sensor at the source is equal to that received by the node 2 device at the tap. If there is a difference, the system will detect water leakages and the node two devices will alert the microcontroller at the source. The system also includes a system administrator, known as the admin, who will log in to the system to remotely monitor and control the water leakages. This is accomplished through the Think Board, which the system administrator will use to view and manage the water leakages.

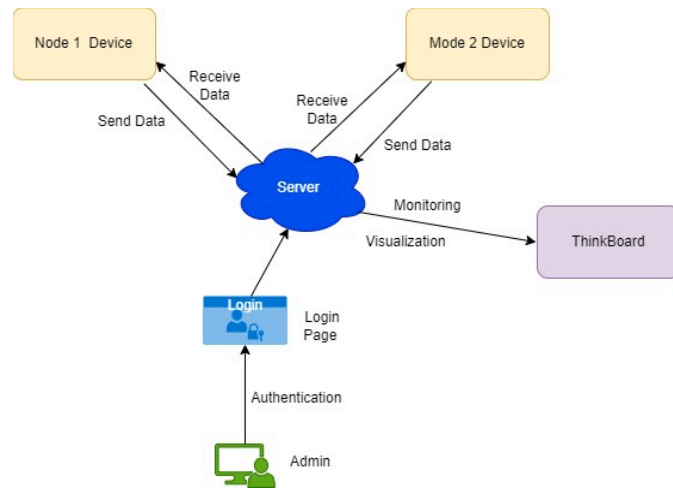

**Figure 4: Conceptual Diagram**

### 3.5 Context Diagram

The context diagram presented in Figure 5 depicts the interaction between the external entities of the Server, Thing Board, and admin. In this case, the admin logs in to the server using the username and password, and the server authenticates the admin to allow the admin to monitor and visualize the data. The admin also can remotely control the solenoid valve on and off, or the system will automatically close it.

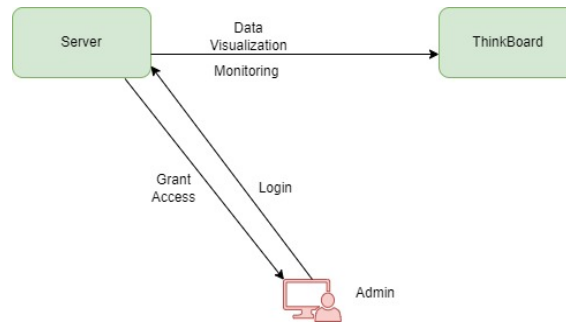
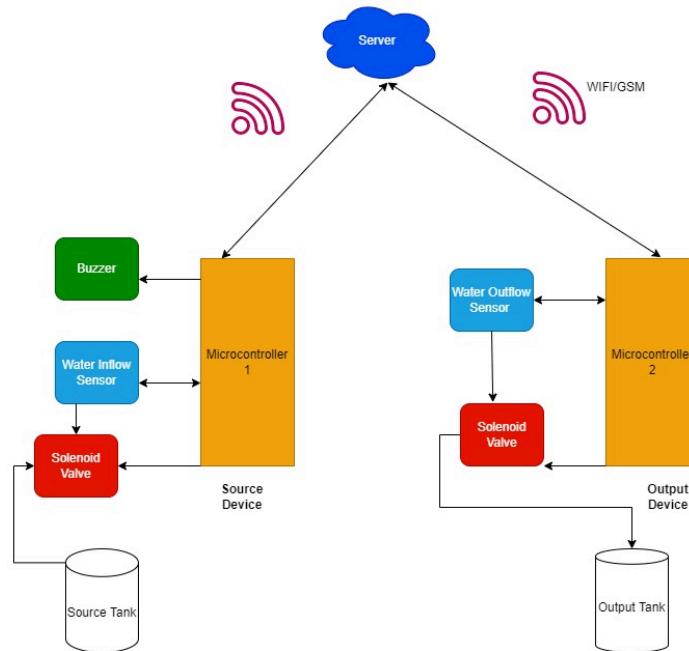

**Figure 5: Context Diagram**

### 3.6 Block/Architectural Diagram

The architectural diagram of the industrial-based GSM water leakage detection, monitoring, and controlling systems presented in Figure 6 shows various components connected to communicate. The first microcontroller in the diagram is located at the source of the pipe and is connected to an inflow water sensor to measure the amount of water, it is also connected to a solenoid valve to control the flow of the water, it can switch on and off the valve to regulate the flow of the water, and the buzzer is used to make an alarm or alert the authority that water leakages have occurred.

At the other end of the pipe is another microcontroller connected to an outflow sensor, a solenoid valve, and a buzzer, and both devices are linked and communicate with one another via the server. The mode of transmission and data communication is WIFI/GSM and (MQTT).



**Figure 6:** Block/Architectural Diagram

### 3.7 Flowchart Diagram

Figure 7 shows the flowchart of various processes happening in the system.

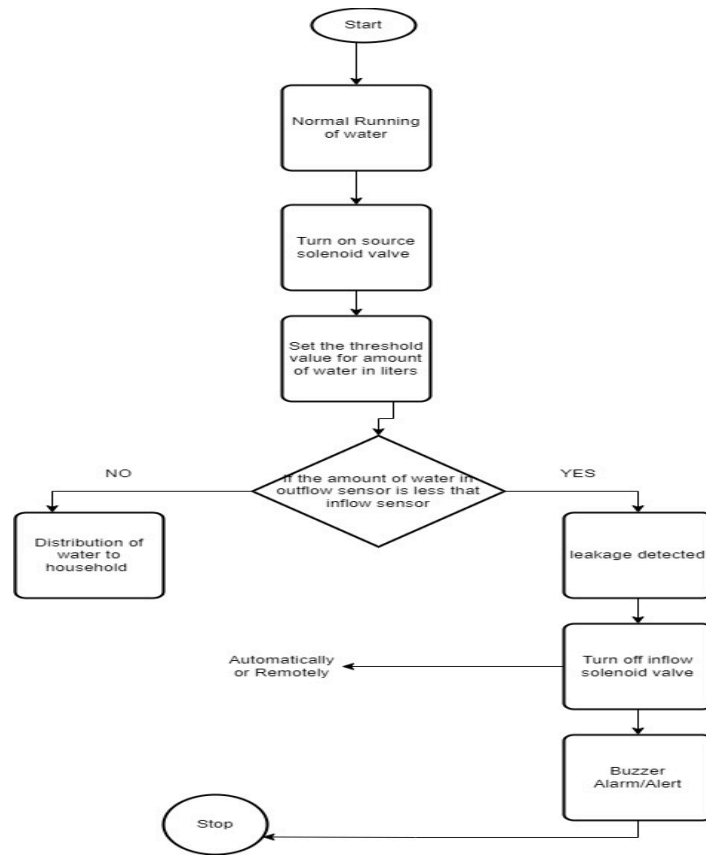
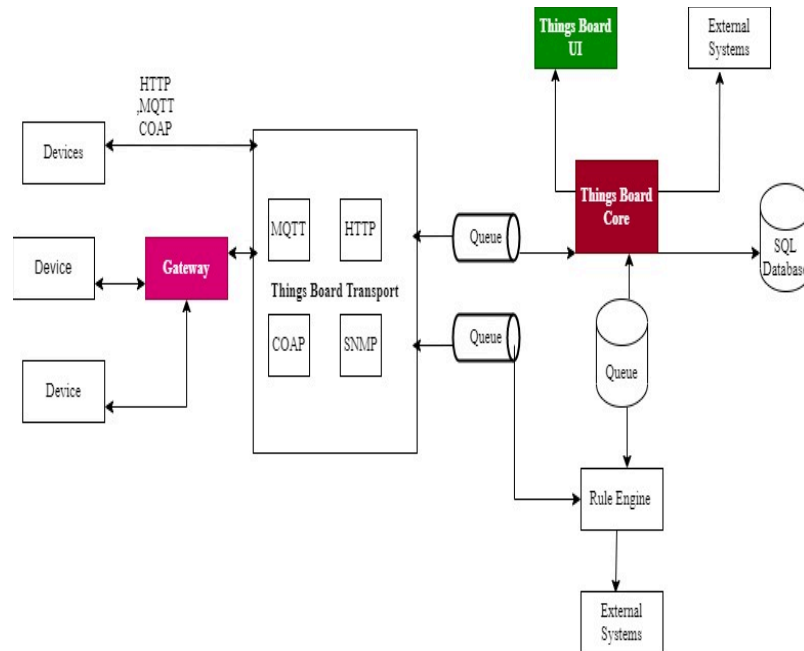

**Figure 7:** Flowchart Diagram

### 3.8 Things Board

Is an open-source IoT platform that collects data, processes it, visualizes it, and manages devices. In this project, IoT was used to ensure data flow from one device to another. Things Board allows devices to communicate with one another via a single server. The source and tap nodes were able to communicate with each other via the server, which interacted with the Things Board via various communication protocols such as (MQTT), Remote Procedure Call (RPC), and WIFI.

The communication technology is based on the subscriber and publisher principle, which states that one node subscribes to the topic by sending data from the node to the server, while the other node publishes the topic by receiving data. The communication between the nodes is accomplished through the use of the WIFI capabilities provided by the ESP 32 microcontroller as shown in Figure 8.

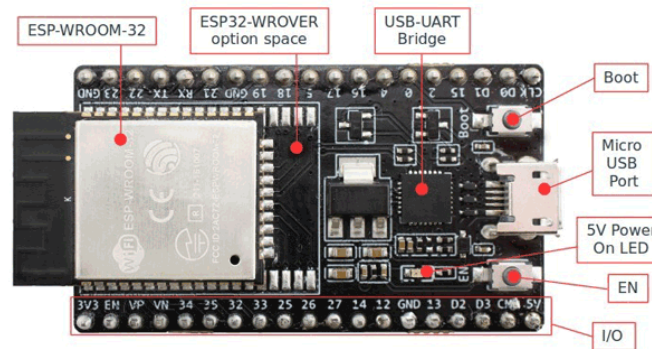

**Figure 8:** Things Board Architecture

### 3.9 ESP 32 Microcontroller

Esp32 development board from Espressif is used for data collection from the sensors, actuation, and communication. The board contains two Lower Xtensa of 32-bit LX6. For the booting process, the microcontroller has 448 Kbytes of read-only memory, which serves as data storage. The chip has 520 Kbytes of on-chip SRAM. The SRAM's main two functions are instruction memory, which is used for code execution whenever the code is loaded to the board, and data memory, which is used to store the data that has been processed. The board includes a wifi module that can transfer data to the cloud or remote areas and is compatible with protocols such as the Message Query Telemetry Transfer protocol, which operates on the publisher-subscriber model.

The board can be integrated with security features such as WPA/WPA2, as well as various encryption and decryption mechanisms. Furthermore, the board has various interfaces such as UART, SPI, and I2C protocols, which are required for connection with various connectors. The operating temperature ranges from -40 to +85 degrees Celsius, and the operating voltage ranges from 2.22 to 3.6 volts, requiring a voltage regulator to regulate the voltage of 12 volts from the main power supply. Figure 9 shows the ESP32 microcontroller's internal part, which consists of various buttons and ports.



**Figure 9:** Outer layout of ESP 32 (eTechnophiles, 2021)

Figure 10 shows the internal layout connection of the ESP32 microcontroller which consists of the various General Input Output Pins (GPIO).

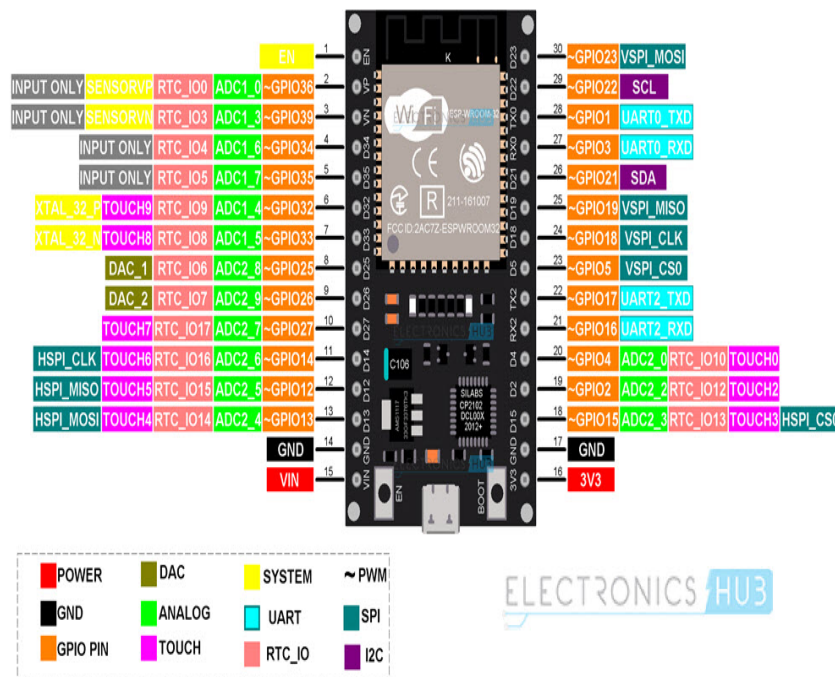

**Figure 10:** Inner layout of ESP32 (eTechnophiles, 2021)

### 3.10 Water Flow Sensor

Water flow in a pipe can be measured using this kind of sensor. The FY-201 sensor was designed and installed in this project on the pipeline, more specifically in the water line. It measures the amount of water that passes through it. The magnetic hall effect sensor used in the sensor generates an electrical signal pulse after each rotation. To keep the sensor secure and dry at all times, the water pipe has a seal around it.

By counting the number of pulses, the magnet emits after each revolution, the amount of water flow rate is determined. The sensor is made up of the wire to which is connected, which represents the signal that will be used to communicate with the microcontroller. It is made up of three wires:

one red wire with a normal operating voltage of +5V, one black wire that acts as a ground to reduce and prevent short circuits from the power source, and one yellow wire that acts as a signal. The yellow wire is used to output the signal to the microcontroller; this is the wire that connects the microcontroller's analogue pin. Water flow is determined and calculated by counting the pulse output by the sensor.

The pulse rate varies with flow rate, fluid pressure, and sensor orientation, and the pulse length is roughly 2.25 milliseconds. The working voltage ranges from 5 to 18VDC (min tested working voltages are 4.5V), the working temperature ranges from -20 to 80, the working humidity ranges from 45% to 80% RH, and the maximum current draw is 15mA. Figure 11 shows the FY-201 water flow sensor.



**Figure 11:** YF-201 water flow sensor (Amazon, 2022)

### 3.11 Integrated Development Environment

Open-source software known as the Arduino Integrated Development Environment (IDE) is used primarily for editing and uploading code to the Arduino board. Because it is open source and simple to install and compile the code, the majority of Arduino modules are compatible with this software. The Java Platform, which is typically built with built-in functions and commands that are necessary for debugging, editing, and compiling code in the environment, is used by the Arduino Integrated Development Environment. This environment is compatible with a wide range of operating systems, including MAC, Windows, and Linux.

The Arduino Mega is the most popular and widely used Arduino module; other options include the Arduino Uno, and Arduino Leonardo. The Arduino Mega has a flash memory of about 256kB, which allows it to load larger code and execute it more quickly than the Arduino Uno, which has 32kB flash memory. In terms of code execution, the code created on the Integrated Development Environment platform is known as a sketch, from which a Hex file is generated and transferred to the microcontroller. The microcontroller used was an ESP32 board, and the IDE environment supported both the C and C++ languages used in developing the system. The IDE environment is



divided into three major sections: The Menu Bar, the Text Editors, and the Output Panel. Figure 12 shows the three parts of the IDE environment.

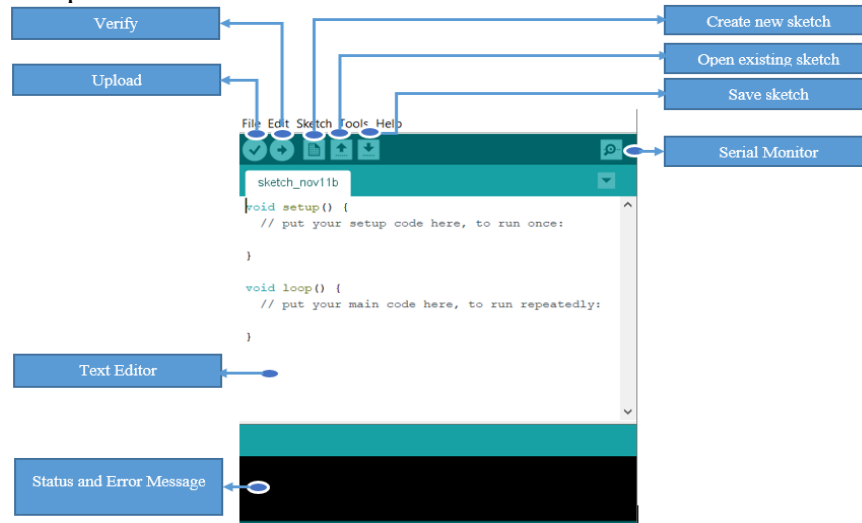

**Figure 12:** Screenshot of the Arduino IDE (Dahoud F. &, 2018)

### 3.12 Proteaus

It is a diagram representation of a printed circuit board in which various components are internally connected and run in virtual environments similar to the real-world environment. The code written in the Arduino platform, which includes an integrated development environment, is imported to the proteaus and loaded into the microcontroller. When the hexadecimal code is uploaded to the microcontroller, the system will operate in a virtual environment, just as it would in a physical one. Figure 13 Shows the Proteaus diagram representation.

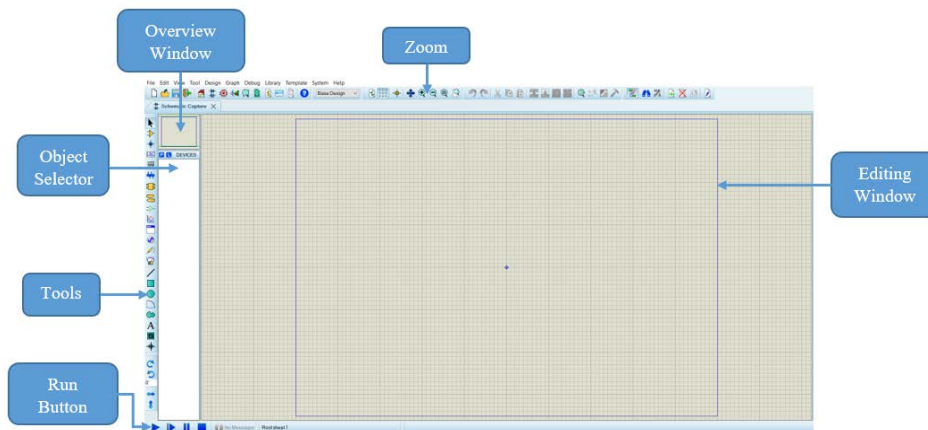

**Figure 13:** Proteaus diagram representation

### 3.13 Functional Requirements

The functional requirements represent the tasks that the system must complete. It is what the system's end user anticipates receiving. Table 1 shows the various functional requirements of the developed system and their descriptions.

**Table 1:** Functional Requirements

<b>Requirement</b>	<b>Description</b>
i) Detect water leakage	When water leaks occur, the system should be able to detect them.
ii) Measure the volume of water	The water flow sensor in the system should be able to measure the volume of water as it flows through the pipe.
iii) Control the flow of water	When water leaks are detected, the system should be able to control the flow of water by turning on and off the solenoid valve.
iv) Giving Alert	If a water leak occurs, the system should be able to notify the authorities. This is accomplished using the Things Board, an IoT platform for visualization.
v) Monitor the flow rate	The system should be able to monitor the water flow rate, which is done using Things Board's real-time flow rate. The administrator must be able to monitor the flow rate in real-time.
vi) Authenticate Admin	The system should be able to authenticate the admin to monitor and visualize data on the Things Board.

### 3.14 Non- Functional Requirements

These are requirements for quality that the system must meet. Non-functional requirements include things like security, maintainability, reliability, efficiency, and convenience. Table 2 shows the non-functional requirements of the system and their descriptions of how the developed system meets the non-functional requirements.

**Table 2:** Non-Functional requirements

<b>Requirement</b>	<b>Description</b>
i) Security	The system should be secured and only authorized users should have access to it.
ii) Reliability	The system should provide precise information about the flow rate at each node, both at the source and destination nodes.
iii) Increase Convenience	It should be very simple and easy to use.
iv) Easy Maintainability	System updates and improvements should be simple to implement.
v) Consistency	The system should provide the consistency of the water flow rate and volume of water in each water flow sensor.

## 4 Results and Discussions

### 4.1 Proposed System from Respondents

Based on the research conducted, 76.9% of the respondents proposed that the developed system incorporated the features of real-time notification and GPS notification respectively, followed by SMS notification at 69.2% and email notification at 38.5% while 30.8% suggested cloud visualization. According to the information, real-time and GPS notification was the best feature to include in the developed system. A summary of the results is presented in Figure 14.

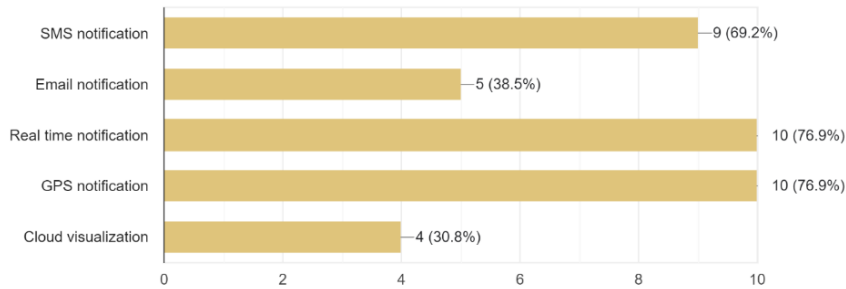

Figure 14: User-Proposed System Features

### 4.2 Web-Based Application

Figure 15 shows the interface where the admin login by entering the username and password to access the server and that is the Things Board in case the username and password are incorrect the systems prompt the user to enter the correct details until the information entered is successful.

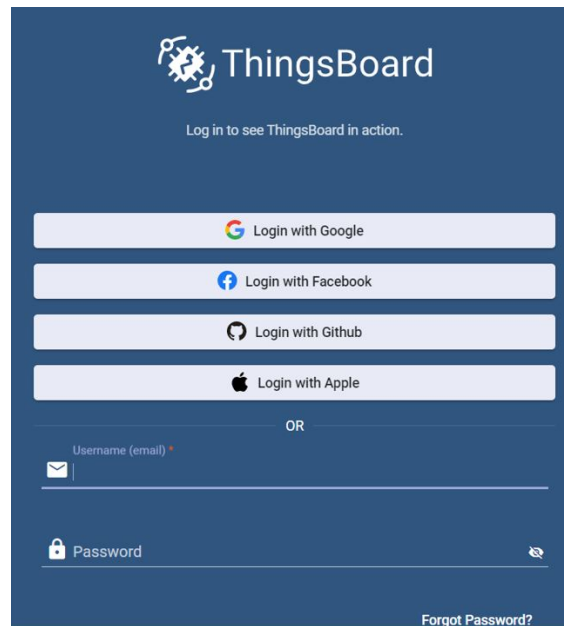
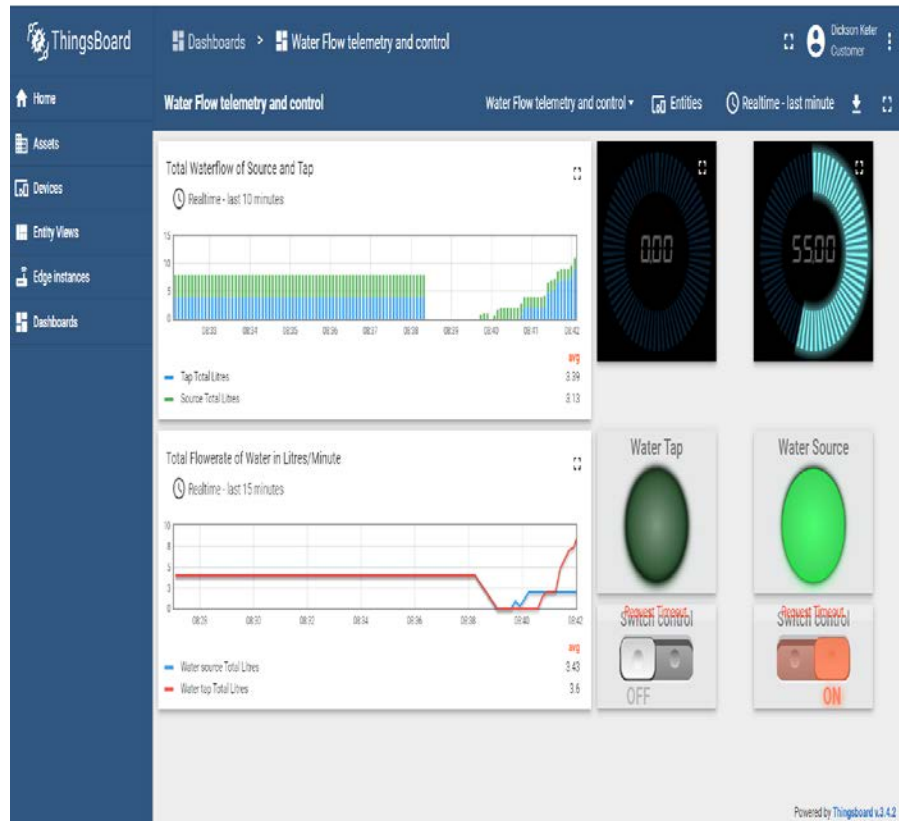

Figure 15: The login page of Things Board

### 4.3 Dashboard of Monitoring Water Flow Rate

Figure 16 displays the water flow rate at the water source as shown on the dashboard as water flows from the storage tank through the source tap where the source node is located. As water flows through the source node, the sensor measures the water's volume and flow rate.



**Figure 16:** Dashboard for Monitoring Water Flow Rate

### 4.4 Thing Board Dashboard Showing the Total Amount of Water in the Source and Tap

The monitoring dashboard shows the total amount of water visible in both the water source and the water tap at the same time. The illustration depicts the general monitoring dashboard, on which the water flow rate and the total amount of water flowing through the pipe were visualized in the Things Board. Water leaks were monitored in real-time, and the administrator could log into the system to control and monitor the leaks remotely and automatically as they occurred. Figure 17 shows the amount of water and the flow rate at each node, which represents the source and water taps. When water leakage occurs, the two remote switches on the right-hand side of the Things Board dashboard control the water flow by switching off and on the valve at each node.

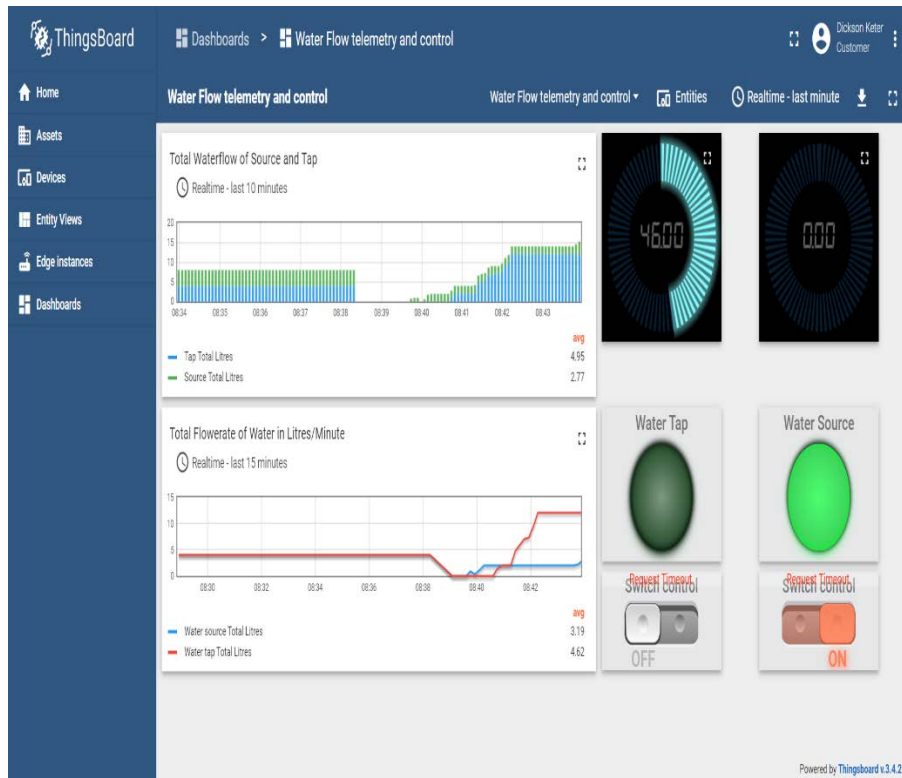
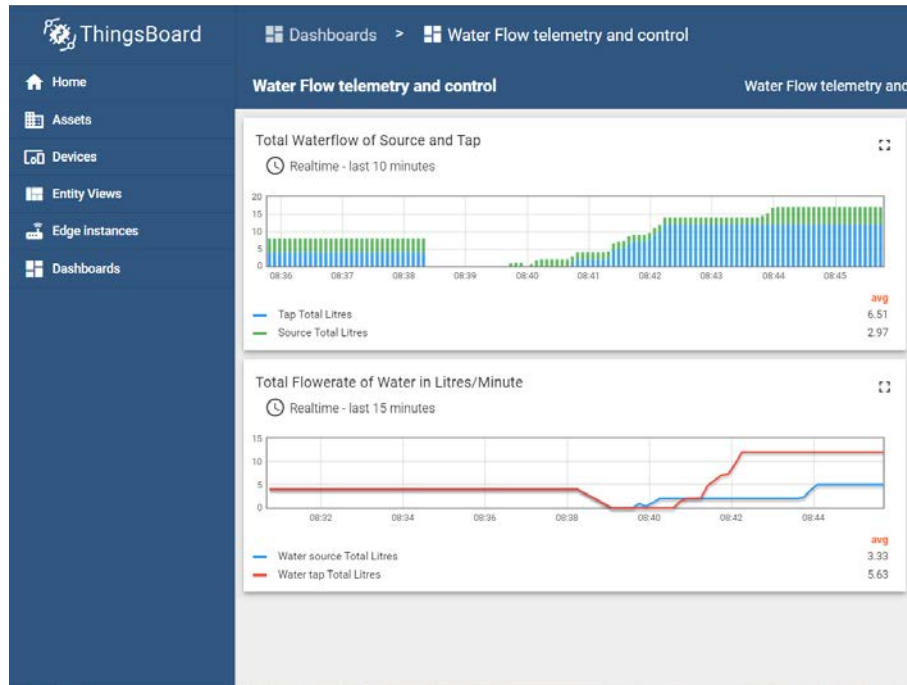

Figure 17: Thing Board Dashboard Showing the Total Amount of Water in the Source and Tap

#### 4.5 Total Flowrate and Amount of Water in Tabs

Figure 18 shows the water flow rate at just the water tap, with the water flow rates almost being equal. Every moment, the water flow rate was observed; in this instance, the water flow rate was monitored. for 15 minutes, from 8:30 a.m. to 8.45 a.m.



**Figure 18:** Total Flowrate and Amount of Water in Tabs

#### 4.6 Switch Control in Source and Tap

Figure 19 depicts two nodes that display the water's flow rate in real-time and is used to track water leaks; as the water passes through the pipe, the two nodes record its flow rate and volume. Each node's water flow rate occurs simultaneously. When there is a water leakage in the system, it can be controlled remotely by closing the water valves, because the flow of the water is monitored in real-time by the administrator.

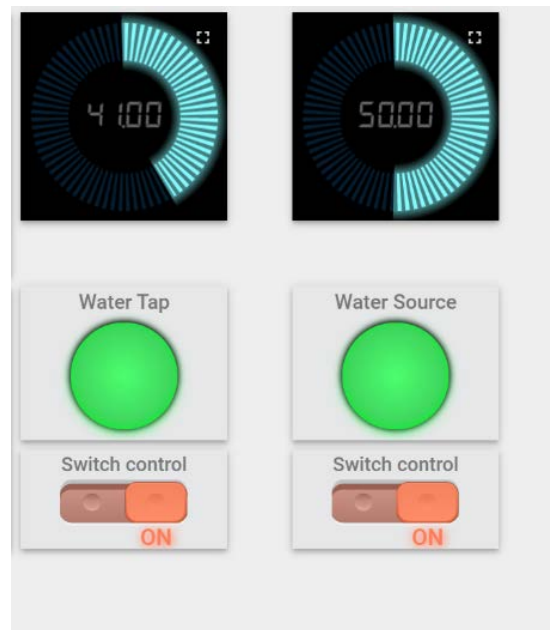

**Figure 19:** Switch Control in Source and Tap

#### 4.7 The Working of the System

The industrial-GSM water leakage detection, monitoring, and controlling system is a real-time monitoring system that detects and controls water leaks from the source to the destination tap. At the source, there is a node made up of an ESP microcontroller, a water flow sensor, a solenoid valve, and a buzzer, which are all linked together to facilitate communication. The water flows through the pipe toward the destination tap, which acts as the outlet; in normal circumstances, the water flows in the pipe without leakage at the destination tap; there is also the node, which is composed of the ESP 32 microcontroller, water flow sensor, solenoid valve, and buzzer are the major components in this project. The purpose of the microcontroller is to control all the components connected to it, the type of flow sensor used in this case is the YF-201 flow sensor which measures the flow rate of the water.

As the water flows through the sensor, the rotor inside the sensor rotates by making the number of revolutions per unit of time, in this case, the unit used is microseconds. To calculate the flow rate of the water passing through the sensor, it is calculated as the number of revolutions per unit of time in this case. In the event of a leak, a solenoid valve was used to control the flow of water from the source to the destination, while a buzzer was used to act as an alarm for notification.

The system consists of two nodes, one in the source tap and another in the destination tap, which can communicate with each other via the server. Two sensors at the source and destination measure the volume of water in normal conditions. If the two sensors have the same volume of water, the two nodes communicate to determine whether there is the same amount of water in both nodes. If there is a slight difference in volume between the nodes, they will communicate with the server to determine what action to take. The necessary precautions are to send a command to the microcontroller to turn off the solenoid valve that controls the flow of water. When the water flow exceeds a certain threshold, the system triggers the microcontroller, which turns off the solenoid

to control the leakage and alerts the authority via the buzzer alarm for the necessary action. Because the system is a real-time monitoring system that can be monitored remotely and controlled while away from the premises as well as while on the premises if a water leakage occurs, the system can detect and control it automatically and remotely via the IoT platform used for real-time visualization and monitoring to prevent further leaks.

The systems have numerous advantages over traditional SMS notifications of water leaks. Among these benefits are:

1. The system administrator's ability to control the system remotely without physically switching on and off the solenoid valve.
2. The overall cost of system development is lower when compared to SMS, which requires monthly subscriptions, whereas the Things Board can only be accessed using the server, via Wi-Fi.
3. The system can be installed in hazardous areas such as valleys and mountains, which can endanger human life.

## 5 System Implementation Overview

Figure 20 shows the FY-201 water flow sensor, which measures the amount of water passing through it, the solenoid valve, which regulates the flow of water through the pipe, and the ESP microcontroller, which controls all of the components connected to it make up the source and destination node subsystem.

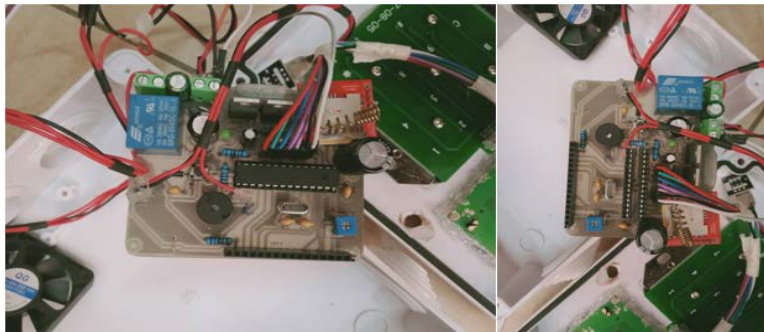

**Figure 20:** Integration of Source and Destination Subsystem

Figure 21 shows the integration of the source and destination subsystems to facilitate communication between the two nodes.



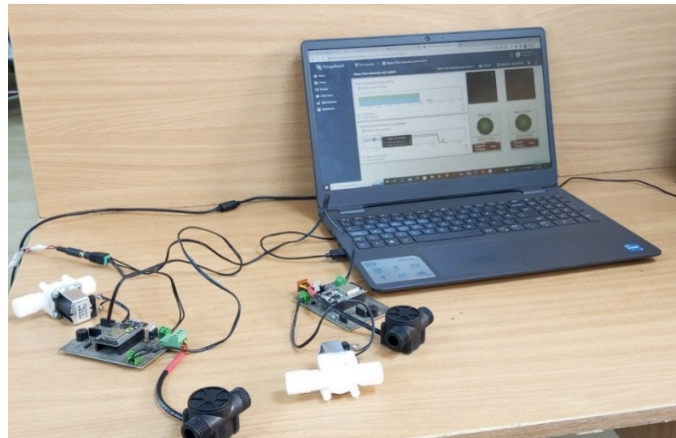

**Figure 21:** Integration of Source and Destination Subsystem

Figure 22 presents the various components of the ESP microcontroller design, such as the pin layout arrangement, which includes General Input Output Pins, Analogue Digital Converters, and I2C communication protocol with pins that are connected internally to the microcontroller.

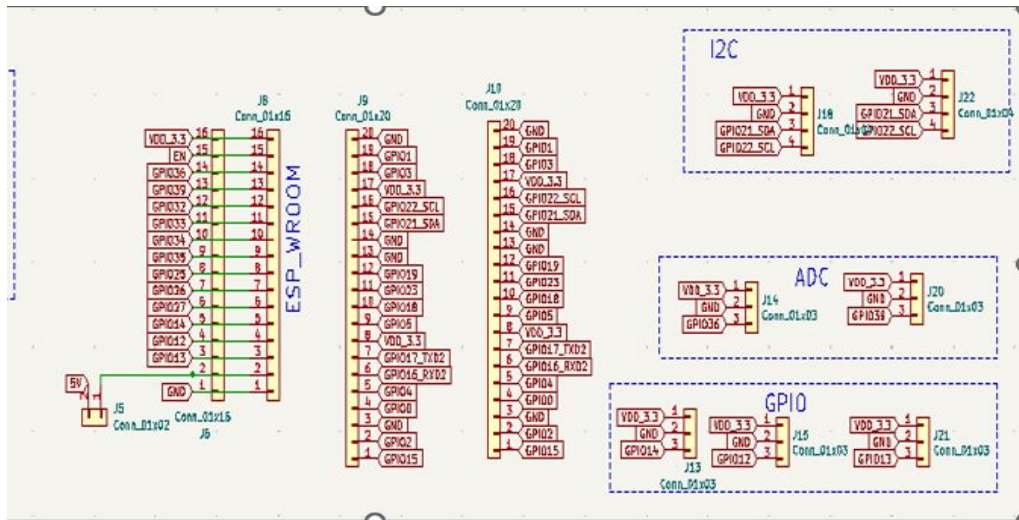

**Figure 22:** Pinout Layout Internal Section of ESP Microcontroller

Figure 23 shows the circuit and how the components are arranged in the circuit.

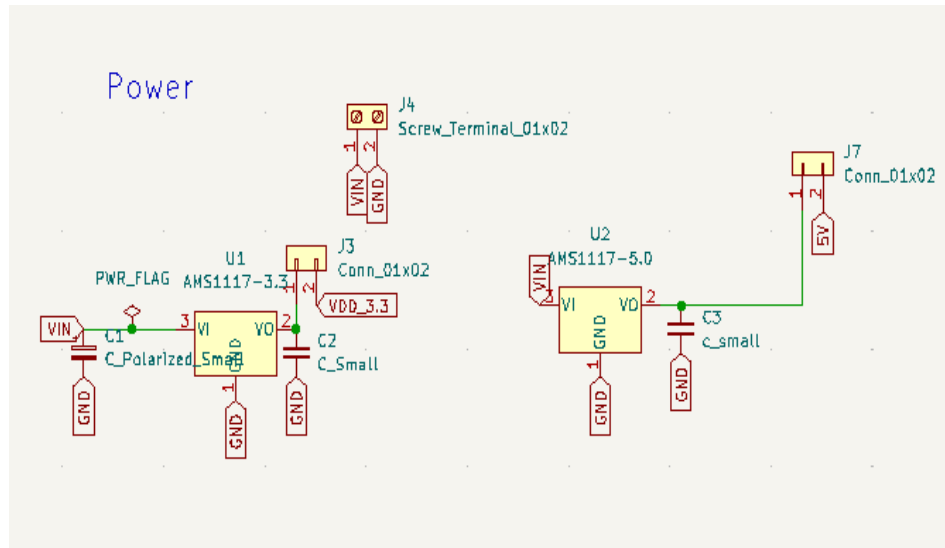

**Figure 23:** Circuit of power design

**5.1 User Acceptance Testing**

Table 3 displays the user responses. It reveals that 33.33% and 66.67% of the respondents strongly agreed or agreed respectively, indicating that the system complies with the requirements. 91.67% and 8.33% strongly agree and agree respectively, indicating that the system was simple to use, while 50% and 41.67% strongly agree and agree respectively that the system is reliable and scalable. 83.33% and 16.67% of responses indicate that the system is efficient.

**Table 3:** User Acceptance Testing

Questions	12 responses				
	Strongly agree	Agree	Not Sure	Disagree	Strongly Disagree
The system works according to the requirements	33.33% (4 responses)	66.67% (8 responses)	-	-	-
System reliability and scalability	50% (6 responses)	41.67% (5 responses)	8.33% (1 response)	-	-
System efficiency	83.33% (10 responses)	16.67% (2 responses)	-	-	-
The system is easy to use	91.67% (11 responses)	8.33% (1 responses)	-	-	-

**6 Conclusion**

In this paper, we developed an automatic, remote, and real-time detection, monitoring, and control system for water leaks. The system was tested by the users on aspects of system reliability, scalability, efficiency, and ease of use and the results were positive. In addition, the system met the user requirements. While the developed system met the design capabilities in terms of technical aspects, functionality, and specification for the proof-of-concept system, the system can be improved in the future to make it more efficient in terms of detection, monitoring, and control and user interface, which is the interaction between the server and Things Board can be made more interactive and simpler. The use of FY-201 water flow sensors for this project demonstrates that advanced systems can be developed using simpler and more sophisticated sensors for greater accuracy and precision. Furthermore, the use of wifi as a means of communication between the two nodes only covered a short-range distance of 80-100 meters. Furthermore, the use of the ESP 32 microcontroller as the control unit for all devices connected was critical in terms of the features that support wireless connectivity and processing power. With the emergence of new technological trends, such as the Internet of Things, the use of these types of microcontrollers will facilitate faster adoption in industrial projects. Because of the rapid growth in internet access in various sectors, including agriculture, health, and education, which has resulted in automation as a result of data-driven technology, the development of a real-time industrial GSM-based water leakage detection, monitoring, and controlling system is of great assistance in this arena of automation.

## 7 Recommendation

Further research is necessary to determine the water flow sensor's precise calibration factor despite pressure differences. However, future research may focus on this as the problem statement shortly, to develop systems capable of finding water leaks in distribution networks that are both dependable and economical. Furthermore, more investigation can be based on identifying leaks at particular points along water pipes by integrating with the Global Positioning System (GPS) to determine their precise location.

## Data Availability Statement

The corresponding author will give the information that backs up the study's results upon request

## Acknowledgments

This work was supported by Center of Excellence for ICT in East Africa (CENT@EA) under Embedded and Mobile Systems (EMoS) program. The Nelson Mandela African Institution of Science and Technology (NM-AIST), Arusha, Tanzania.

**Authors' Contribution:** All three authors contributed equally

**Conflicts of Interest:** Authors state that they have no competing interests in the publication of this research



Copyright by the author(s). This is an open-access article distributed under the Creative Commons Attribution License (CC BY-NC International, <https://creativecommons.org/licenses/by/4.0/>), which allows others to share, make adaptations,

tweak, and build upon your work

non-commercially, provided the original work is properly cited. The authors can reuse their work commercially.

## References

- [1] Bhattacharjee, P. K. (2010). Global Warming Impact on the Earth. *International Journal of Environmental Science and Development*, 219–220. <https://doi.org/10.7763/IJESD.2010.V1.41>
- [2] Salem, Hilmi S.; Pudza, Musa Yahaya; Yihdego, Yohannes .(2022). Water strategies and water–food Nexus: challenges and opportunities towards sustainable development in various regions *World Sustainable Water Resources Management*, page 114.
- [3] Birhanu, B. Z.; Sanogo, K.;Traore, S.; Thai, M.; Kizito, F.(2023). Solar-based irrigation systems as a game changer to improve agricultural practices in sub-Sahara Africa: A case study *Frontiers in Sustainable Food Systems* -1085335.
- [4] Yıldırım, M. (2015). The Importance of Technological Resources in the Educational System in Design. *Procedia - Social and Behavioral Sciences*, 182, 502–506. <https://doi.org/10.1016/j.sbspro.2015.04.834>.
- [5] Al Qahtani, T., Yaakob, M. S., Yidris, N., Sulaiman, S., & Ahmad, K. A. (2020). A review on water leakage detection method in the water distribution network. *Journal of Advanced Research in Fluid Mechanics and Thermal Sciences*, 68(2), 152–163.
- [6] Palpandian, P., Govindaraj, V., Dharmashastha, S., Gokul, S., & Mari Selvam, K. (2021). Water Pipeline Leakage Detection and Control Management System Using Iot. *Annals of the Romanian Society for Cell Biology*, 5752–5757.
- [7] Rahmat, R. F., Satria, I. S., Siregar, B., & Budiarto, R. (2017). Water pipeline monitoring and leak detection using flow liquid meter sensor. *IOP Conference Series: Materials Science and Engineering*, 190(1), 012036.
- [8] Jayapal, C. (n.d.). Water Leakage Management using Digital Twin. *Journal of Huazhong University of Science and Technology*. Vol 50(5), 1-10.
- [9] John, J. A., & Nivash, S. (2016). Monitoring and Controlling the Water Leakage using Robotic Arm. *International Journal of Engineering Research*, 5(03).
- [10] JayaLakshmi, M., & Gomathi, V. (2015). An enhanced underground pipeline water leakage monitoring and detection system using wireless sensor network. *2015 International Conference on Soft-Computing and Networks Security (ICSNS)*, 1–6.
- [11] Herrera-Vega, E. (2022). Harnessing Ethical AI Surveillance for Climate Change Governmentality. *Transdisciplinary Journal of Engineering and Science*, 13, 129–146. <https://doi.org/10.22545/2022/00205>
- [12] Aguilar, C. H., López, F. S., & Pacheco, F. A. D. (2022). Sustainable Development Goals index: An analysis (2000-2022). *Transdisciplinary Journal of Engineering and Science*, 13, 111–128. <https://doi.org/10.22545/2022/00213>

[13] Savenije, H. H. G. (1992). *Water and Sustainable Development*. <https://www.researchgate.net/publication/303523018>

[14] Loucks, D. P. (1997). Quantification des tendances de la durabilité des systèmes. *Hydrological Sciences Journal*, 42(4), 513–530. <https://doi.org/10.1080/02626669709492051>

[15] Sun, S., Wang, Y., Liu, J., Cai, H., Wu, P., Geng, Q., & Xu, L. (2016). Sustainability assessment of regional water resources under the DPSIR framework. *Journal of Hydrology*, 532, 140–148. <https://doi.org/10.1016/j.jhydrol.2015.11.028>

[16] Cetinkaya, C. P., Fistikoglu, O., Fedra, K., & Harmancioglu, N. B. (2008). Optimization methods applied for sustainable management of water-scarce basins. *Journal of Hydroinformatics*, 10(1), 69–95. <https://doi.org/10.2166/hydro.2007.011>

[17] Lawrence, R. J. (2022). Being Human: Rethinking Adaptation and Resilience. *Transdisciplinary Journal of Engineering and Science*, 13, 147–160. <https://doi.org/10.22545/2022/00208>

## About the Author



**Tuwei K. Dickson** earned his B.Sc. degree in computer science from Moi University, Kenya. He is currently pursuing his M.Sc. degree in embedded and mobile systems specializing in embedded systems, School of Computational and Communication Science and Engineering(CoCSE). The Nelson Mandela African Institution of Science and Technology (NM-AIST), Arusha 447, Tanzania. He is an active member of IEEE. His research interests include the Internet of Things, Automation, Embedded Systems, Robotics, and Artificial Intelligence.



**Dr. Neema Mduma** is a computer science professional working as a lecturer in the School of Computational and Communication Science and Engineering (CoCSE) at the Nelson Mandela African Institution of Science and Technology (NM-AIST), Arusha 447, Tanzania. She has a PhD in Information and Communication Sciences and Engineering from the same Institution. Neema is passionate about education, particularly to girls she is the founder of BakiShule which aims at preventing students from dropping out of school. Neema also serves as a researcher in three projects i.e Student Dropout Prediction(2017), School Dropout Visualization (2018), and LisheYetu (2019) which won the data for a local impact challenge funded by The United States President's Emergency Plan for AIDS Relief(PEPFAR) and World Food Programme(WFP) through Tanzania Data Lab (dLab). Each project was given 25,000 USD to facilitate their innovative ideas for solving society's problems related to student dropout, HIV/AIDS, and malnutrition. Currently, she is serving as the reviewer at the International Conference of Machine Learning (ICML), Association for Computing Machinery (ACM), Black in Artificial Intelligence (BAI) and Women in Machine Learning (WiML). Her area of research includes Machine Learning, Data Mining, Mobile Commerce and Document Engineering and Information Architecture



**Dr. John K. Tarus** holds PhD in computer science at Beijing Institute of Technology, China. Master of Philosophy in Information Technology at Moi University and B.Sc. in Mathematics and Computer Science at Jomo Kenyatta University of Agriculture and Technology, Kenya. Currently is a lecturer at Moi University teaching at the Department of Information Technology School of Information Sciences. He is a serving president of Internet Society Kenya and a member of the ISOC Chapters Advisory Council Steering Committee. He was a part-time lecturer at Kenya Institute of Management (2002-2003) and a lecturer at Alphax College (2003-2004). His area of research includes Databases, System Administration, Intelligent Systems, and the Internet of Things